

# Smart Maintenance System for Inner City Public Bus Services

by

Paul-Roux Hendrik de Villiers

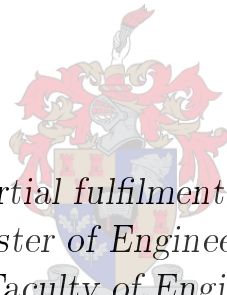

*Thesis presented in partial fulfilment of the requirements for  
the degree of Master of Engineering (Engineering  
Management) in the Faculty of Engineering at Stellenbosch  
University*

*This thesis has also been presented at Reutlingen University,  
Germany, in terms of a double-degree agreement*

Supervisor: Dr. J.L. Jooste

Co-supervisor: Prof. Dr.-Ing. D. Lucke

December 2022

# Declaration

By submitting this thesis electronically, I declare that the entirety of the work contained therein is my own, original work, that I am the sole author thereof (save to the extent explicitly otherwise stated), that reproduction and publication thereof by Stellenbosch University will not infringe any third party rights and that I have not previously in its entirety or in part submitted it for obtaining any qualification.

Date: ..... December 2022 .....

Copyright © 2022 Stellenbosch University  
All rights reserved.

# Abstract

## Smart Maintenance System for Inner City Public Bus Services

PH de Villiers

*Department of Industrial Engineering,  
University of Stellenbosch,  
Private Bag X1, Matieland 7602, South Africa.*

Thesis: MEng (Engineering Management)

December 2022

Maintenance is increasingly being digitalised in line with the transpiring Industry 4.0 movement. This trend sees the realisation of smart maintenance strategies and systems that allow organisations to take better control of their maintenance. Inner city public bus services contribute to the sustainability of cities and can only do so if they possess the means to provide trouble-free and effective transportation. The opportunity exists to develop a smart maintenance system for these organisations to minimise the downtime of unexpected breakdowns and ensure the reliable operation of inner city buses.

The identified problem is that the maintenance approaches and systems that are currently in use at inner city public bus services are based on previous technological and industrialisation methods. Smart maintenance and Industry 4.0 technologies can optimise maintenance at these organisations and support informed decision-making. A literature review is conducted that identifies the Industry 4.0 technologies that support smart maintenance and the fundamental requirements

*ABSTRACT***iv**

of a smart maintenance system. Based on the feedback from an internationally conducted empirical investigation it is found that inner city bus services utilise Industry 4.0 technologies only to a minimal degree in their maintenance practices. This investigation also determined the parameters influencing the reliability and causing downtime of inner city buses.

The smart maintenance system is designed by taking into account the findings from an extensive literature review and the feedback from structured interviews with representatives of bus services. Requirements for the smart maintenance system are defined, and an architecture is laid out that positions the functions of the system. Validation of the system is performed as a case study with an industry partner. For conducting the case study, a concept demonstrator is designed according to the defined system and addresses the main problem causing downtime of the buses at the industry partner. Tests are conducted with the demonstrator to verify the smart maintenance system's functionalities.

# Uittreksel

## **Slim Instandhoudingstelsel vir Binnestedelike Openbare Busdienste**

*(“Smart Maintenance System for Inner City Public Bus Services”)*

PH de Villiers

*Departement Bedryfsingenieurswese,  
Universiteit van Stellenbosch,  
Privaatsak X1, Matieland 7602, Suid Afrika.*

Tesis: MIng (Ingenieursbestuur)

Desember 2022

Instandhouding word toenemend gedigitaliseer in ooreenstemming met die huidige Industrie 4.0 beweging. Hierdie tendens sien die verwesenliking van slim instandhoudingstrategieë en -stelsels wat organisasies in staat stel om beter beheer oor hul eie instandhouding te neem. Binnestedelike openbare busdienste dra by tot die volhoubaarheid van stede en kan dit slegs doen as hulle oor die nodige middele beskik om probleemvrye en doeltreffende vervoer te verskaf. Daar bestaan 'n geleentheid om 'n slim instandhoudingstelsel vir hierdie organisasies te ontwikkel om die staantyd van onverwagte onklaarrakings te minimaliseer en die betroubare werking van binnestedelike busse te verseker.

Die geïdentifiseerde probleem is die instandhoudingsbenaderings en -stelsels wat tans by binnestedelike openbare busdienste gebruik word, is gebaseer op vorige tegnologiese en industrialisasiemetodes. Slim instandhouding en Industrie 4.0

tegnologieë kan instandhouding by hierdie organisasies optimiseer en ingeligte besluitneming ondersteun. 'n Literatuurstudie word gedoen om die Industrie 4.0 tegnologieë te identifiseer wat slim instandhouding ondersteun. Die literatuurstudie bepaal ook die fundamentele vereistes van 'n slim instandhoudingstelsel. Gebaseer op die terugvoer van 'n internasionaal uitgevoerde empiriese ondersoek word bevind dat binnestedelike busdienste Industrie 4.0 tegnologieë minimaal in hul instandhoudingspraktyke benut. Hierdie ondersoek het ook bepaal wat die betroubaarheid en onklaarraking van binnestedelike busse beïnvloed.

Die slim instandhoudingstelsel is ontwerp deur die bevindinge van 'n uitgebreide literatuurstudie en die terugvoer van gestruktureerde onderhoude met verteenwoordigers van busdienste in ag te neem. Vereistes vir die slim instandhoudingstelsel word gedefinieer, en 'n argitektuur word uitgelê wat die funksies van die stelsel posisioneer. Validasie van die stelsel word uitgevoer as 'n gevallestudie met 'n bedryfsvennoot. Vir die uitvoering van die gevallestudie word 'n konsepdemonstreerder volgens die gedefinieerde stelsel ontwerp wat die hoofprobleem van onklaarraking van die busse by die bedryfsvennoot veroorsaak, aanspreek. Toetse word met die demonstreerder uitgevoer ten einde die slim instandhoudingstelsel se funksionaliteite te verifieer.

# Dedications

*Aan my ouers, Paul en Mandi*

# Acknowledgements

I would like to express my deep and sincere gratitude to everyone who assisted and supported me during the completion of my thesis. Particularly, I would like to acknowledge and thank the following people:

- My parents, Paul and Mandi, for providing their love, emotional support, and encouragement on a continuous basis.
- My girlfriend, Minette, who was always there when I needed her, for her love, support, and frequent enlightening discussions.
- My supervisors, Dr. J.L. Jooste and Prof. Dr.-Ing. D. Lucke, for providing me with superior guidance and support.
- The participants that took part in my interviews for offering their time to share their valuable knowledge and experience.
- The case study organisation with whom I worked in close cooperation for giving me access to their facilities and for assisting me where they could.
- My fellow DIME students for all the inspirational discussions and the wonderful experiences we have shared over the past few years.

The Author

December 2022



# Contents

<b>Declaration</b>	<b>ii</b>
<b>Abstract</b>	<b>iii</b>
<b>Uittreksel</b>	<b>v</b>
<b>Dedications</b>	<b>vii</b>
<b>Acknowledgements</b>	<b>viii</b>
<b>Contents</b>	<b>ix</b>
<b>List of Figures</b>	<b>xiv</b>
<b>List of Tables</b>	<b>xvii</b>
<b>Acronyms</b>	<b>xviii</b>
<b>1 Introduction</b>	<b>1</b>
1.1 Background and Rationale of the Research . . . . .	2
1.2 Research Problem Statement and Questions . . . . .	6
1.3 Research Objectives . . . . .	7
1.4 Research Methodology and Design Overview . . . . .	8
1.5 Ethical Considerations . . . . .	8
1.6 Limitations and Delimitations . . . . .	8
1.7 Contributions . . . . .	9
1.8 Chapter Outline . . . . .	10

1.9	Chapter Summary . . . . .	11
<b>2</b>	<b>Literature Review</b>	<b>12</b>
2.1	Maintenance . . . . .	13
2.1.1	Definition of Maintenance . . . . .	13
2.1.2	Maintenance Strategies . . . . .	15
2.1.2.1	Reactive Maintenance . . . . .	16
2.1.2.2	Preventive Maintenance . . . . .	17
2.1.2.3	Condition-based Maintenance . . . . .	17
2.1.2.4	Predictive Maintenance . . . . .	18
2.1.2.5	Smart Maintenance . . . . .	20
2.1.3	Smart Maintenance System . . . . .	23
2.2	Industry 4.0 Technologies Supporting Smart Maintenance . . . . .	26
2.2.1	Big Data and Analytics . . . . .	27
2.2.2	Internet of Things (IoT) . . . . .	29
2.2.3	Cloud Computing . . . . .	31
2.2.3.1	Fog Computing . . . . .	31
2.2.3.2	Edge Computing . . . . .	32
2.2.4	Cyber-Physical System (CPS) . . . . .	32
2.2.5	Artificial Intelligence (AI) . . . . .	34
2.3	Inner City Public Bus Services . . . . .	35
2.3.1	Organisational Structure . . . . .	35
2.3.2	Inner City Buses . . . . .	37
2.3.2.1	Operating Conditions . . . . .	37
2.3.2.2	Power Train . . . . .	38
2.3.3	Bus Maintenance . . . . .	40
2.4	Prognostics and Health Management (PHM) . . . . .	41
2.4.1	Vehicle Diagnostics . . . . .	42
2.4.1.1	On-Board Diagnostics (OBD) . . . . .	42
2.4.1.2	Controller Area Network (CAN) . . . . .	43
2.4.1.3	J1939 . . . . .	43
2.4.2	Prognostic Approaches . . . . .	44
2.5	Related Research . . . . .	46

<i>CONTENTS</i>	<b>xi</b>
2.5.1 Cloud-Based Driver Monitoring and Vehicle Diagnostic with OBD-II Telematics . . . . .	46
2.5.1.1 System . . . . .	46
2.5.1.2 Results . . . . .	48
2.5.2 A Field Test With Self-organized Modelling for Knowledge Discovery in a Fleet of City Buses . . . . .	48
2.5.2.1 System . . . . .	48
2.5.2.2 Results . . . . .	50
2.5.3 IoT-based Predictive Maintenance for Fleet Management . .	50
2.5.3.1 System . . . . .	51
2.5.3.2 Results . . . . .	52
2.5.4 Predictive Maintenance of Bus Fleet by Intelligent Smart Electronic Board Implementing Artificial Intelligence . . . . .	53
2.5.4.1 System . . . . .	53
2.5.4.2 Results . . . . .	55
2.5.5 Related Research Summary . . . . .	56
2.6 Chapter Summary . . . . .	56
<b>3 Research Design and Methodology</b>	<b>57</b>
3.1 Research Approach . . . . .	57
3.1.1 Philosophical Worldview . . . . .	58
3.1.2 Research Design . . . . .	59
3.1.3 Research Methodology . . . . .	60
3.2 Chapter Summary . . . . .	61
<b>4 Empirical Investigation</b>	<b>62</b>
4.1 Empirical Investigation Conditions . . . . .	63
4.2 Structure of Interviews . . . . .	65
4.2.1 Part 1: Acquire Context . . . . .	65
4.2.2 Part 2: Industry 4.0 Technology Maturity . . . . .	65
4.2.3 Part 3: Factors Influencing Bus Reliability . . . . .	66
4.2.4 Part 4: Smart Maintenance . . . . .	66
4.3 Empirical Investigation Results . . . . .	67

<i>CONTENTS</i>	<b>xii</b>
4.3.1 Part 1: Acquire Context . . . . .	67
4.3.2 Part 2: Industry 4.0 Technology Maturity . . . . .	68
4.3.3 Part 3: Factors Influencing Bus Reliability . . . . .	69
4.3.4 Part 4: Smart Maintenance . . . . .	71
4.3.5 Interview Results Discussion . . . . .	73
4.4 Chapter Summary . . . . .	75
<b>5 Smart Maintenance System Development</b>	<b>76</b>
5.1 System Requirements . . . . .	77
5.2 System Functions . . . . .	81
5.2.1 Condition Monitoring System . . . . .	81
5.2.2 IoT Network . . . . .	82
5.2.3 Smart Maintenance Planning . . . . .	82
5.2.4 Smart Maintenance System . . . . .	84
5.3 Concept Demonstrator . . . . .	85
5.3.1 Demonstrator Design Approach . . . . .	85
5.3.2 Hardware & Software . . . . .	86
5.4 Chapter Summary . . . . .	88
<b>6 Concept Demonstrator Development</b>	<b>89</b>
6.1 Concept Demonstrator Setup . . . . .	90
6.1.1 Hardware Setup . . . . .	90
6.1.2 Software Setup . . . . .	93
6.2 Experiment Design . . . . .	96
6.3 Chapter Summary . . . . .	98
<b>7 System Validation</b>	<b>99</b>
7.1 Concept Demonstrator Case Study . . . . .	100
7.2 System Evaluation . . . . .	106
7.3 System Refinement . . . . .	109
7.4 Chapter Summary . . . . .	110
<b>8 Conclusion and Recommendations</b>	<b>111</b>
8.1 Research Summary . . . . .	111

<i>CONTENTS</i>	<b>xiii</b>
8.2 Research Contributions and Conclusions . . . . .	113
8.3 Limitations . . . . .	116
8.4 Further Research Recommendations . . . . .	117
8.5 Chapter Summary . . . . .	118
<b>List of References</b>	<b>119</b>
<b>Appendices</b>	<b>138</b>
<b>A Interviews</b>	<b>139</b>
A.1 Research Ethics Committee Approval . . . . .	140
A.2 Consent Form . . . . .	143
A.3 Institutional Permission . . . . .	147
A.3.1 Institutional Permission Application . . . . .	147
A.3.2 Institutional Permission Letter . . . . .	149
A.4 Interview Schedule . . . . .	150
<b>B Concept Demonstrator</b>	<b>155</b>
B.1 Parts List and Cost . . . . .	155
B.2 Arduino Integrated Development Environment (IDE) Programming	156

# List of Figures

1.1	The exploratory sequential design (Adopted from Creswell and Creswell, 2018, p. 69) . . . . .	8
1.2	Chapter outline . . . . .	10
2.1	Maintenance subdivisions (Adopted from DIN31051, 2019, p. 12) . . . .	13
2.2	Wear margin (Adopted from DIN31051, 2019, p. 8) . . . . .	14
2.3	Reference model for the development of maintenance strategies (Adopted from Ermonts-Holley, 2016) . . . . .	16
2.4	Hierarchy of prognostic approaches (Adopted from Byington <i>et al.</i> , 2002, p. 2815) . . . . .	19
2.5	Data-driven decision-making factors (Adopted from Bokrantz <i>et al.</i> , 2019, p. 7) . . . . .	21
2.6	Six categories of human capital resource (Adopted from Bokrantz <i>et al.</i> , 2019, p. 7) . . . . .	21
2.7	Internal integration factors (Adopted from Bokrantz <i>et al.</i> , 2019, p. 7) . . . . .	22
2.8	External integration factors (Adopted from Bokrantz <i>et al.</i> , 2019, p. 7) . . . . .	22
2.9	Architecture of a future maintenance planning system (Adopted from Lucke <i>et al.</i> , 2017, p. 83) . . . . .	25
2.10	Processes for extracting insights from Big Data (Adopted from Gandomi and Haider, 2015, p. 141) . . . . .	28
2.11	5C architecture for industrial Cyber-Physical System (Adopted from Sinha and Roy, 2020, p. 107) . . . . .	32
2.12	Different AI algorithms (Adopted from Ochella and Shafiee, 2019, p. 3427) . . . . .	35

<i>LIST OF FIGURES</i>	<b>xv</b>
2.13 Driveshaft assembly of 15 m long low floor city bus (Adopted from Kaczalski and Slaski, 2018) . . . . .	38
2.14 Structure of power train system of hybrid city bus (Adopted from Chen <i>et al.</i> , 2014, p. 4284) . . . . .	39
2.15 Classification of Prognostics and Health Management (PHM) approaches (Adopted from Bailey <i>et al.</i> , 2015, p. 2) . . . . .	44
2.16 Predictive maintenance fleet management system architecture-overview diagram (Adopted from Killeen <i>et al.</i> , 2019, p. 609) . . . . .	51
2.17 Architecture of the data acquisition on-board system (Adopted from Massaro <i>et al.</i> , 2020, p. 182) . . . . .	54
3.1 Research framework (Adopted from Creswell and Creswell, 2018, p. 43)	58
4.1 Maturity level of Industry 4.0 technologies at inner city public bus services	69
4.2 Factors influencing the degradation in the reliability of an inner city bus	70
4.3 Aspects to consider for smart maintenance . . . . .	72
4.4 Importance rating of smart maintenance system requirements . . . . .	73
5.1 Condition monitoring functions of the system . . . . .	81
5.2 IoT functions of the system . . . . .	82
5.3 Smart maintenance planning functionality . . . . .	84
5.4 Architecture of the smart maintenance system for inner city public bus services . . . . .	84
5.5 Concept demonstrator configuration . . . . .	88
6.1 Voltage divider circuit (Fransiska <i>et al.</i> , 2013) . . . . .	90
6.2 Concept demonstrator voltage divider circuit . . . . .	91
6.3 Concept demonstrator voltage regulator . . . . .	92
6.4 <i>NodeMCU ESP8266</i> Pin definition (Espressif, 2020) . . . . .	92
6.5 Concept demonstrator layout . . . . .	93
6.6 Flow diagram of code logic . . . . .	94
6.7 <i>ThingSpeak</i> react function . . . . .	95
6.8 <i>IFTTT</i> notification configuration . . . . .	96
7.1 Testing with DC bench power supply . . . . .	101

*LIST OF FIGURES*

xvi

7.2	Mobile phone application notification . . . . .	102
7.3	Wi-Fi router and device ready for installation . . . . .	103
7.4	<i>ThingSpeak</i> interface . . . . .	103
7.5	Data collected during two operational days . . . . .	104
7.6	Battery voltage monitored over weekend . . . . .	105



# List of Tables

1.1	Research questions of thesis . . . . .	6
1.2	Objectives of thesis . . . . .	7
3.1	Breakdown of research design and methodology . . . . .	61
4.1	Key components responsible for downtime . . . . .	70
5.1	Smart maintenance system requirements . . . . .	80
6.1	Concept demonstrator test cycles . . . . .	98
7.1	Concept demonstrator accuracy test before calibration . . . . .	101
7.2	Concept demonstrator accuracy test after calibration . . . . .	102
7.3	Smart maintenance system requirements fulfilment . . . . .	108
B.1	Concept demonstrator parts list and cost . . . . .	155

# Acronyms

AI	Artificial Intelligence
AM	Asset Management or Physical Asset Management
ANNs	Artificial Neural Networks
API	Application Programming Interface
CAN	Controller Area Network
CBM	Condition-based Maintenance
CEP	Complex Event Processor
CMMS	Computerised Maintenance Management System
COSMO	Consensus Self-Organised Models
CPS	Cyber-Physical System
DTC	Diagnostic Trouble Code
ECU	Electronic Control Unit
ECUs	Electronic Control Units
EPA	Environmental Protection Agency
GABS	Golden Arrow Bus Service
GUI	Graphical User Interface
HTTP	Hypertext Transfer Protocol

## ACRONYMS

xix

ICOSMO	Improved Consensus Self-Organised Models
ICT	Information and Communications Technology
IDE	Integrated Development Environment
IoT	Internet of Things
ISO	International Organisation for Standardisation
IT	Information Technology
KPI	Key Performance Indicator
KPIs	Key Performance Indicators
MAF	Mass Air Flow
MLP-ANN	Multilayer Perceptron Artificial Neural Network
MQTT	Message Queuing Telemetry Transport
MSE	Mean Squared Error
MTBF	Mean Time Between Failures
MTTR	Mean Time to Repair
MVG	Münchner Verkehrsgesellschaft
OBD	On-Board Diagnostics
OEM	Original Equipment Manufacturer
OPEX	Operational Expenditure
PGN	Parameter Group Number
PHM	Prognostics and Health Management
PROMETHEE	Preference Ranking Organisation Method for Evaluation
PRQ	Primary Research Question
RN	Root Node
RO	Research Objective
SAE	Society of Automotive Engineers

*ACRONYMS*

**xx**

SLN Server Leader Node  
SPN Suspect Parameter Number  
SRQ Secondary Research Question

TBM Time-based Maintenance

UITP International Association of Public Transport

VN Vehicle Node

# Chapter 1

## Introduction

*Research is to see what everybody else has seen, and to think what nobody else has thought.*

*- Albert Szent-Gyorgyi (1893-1986)*

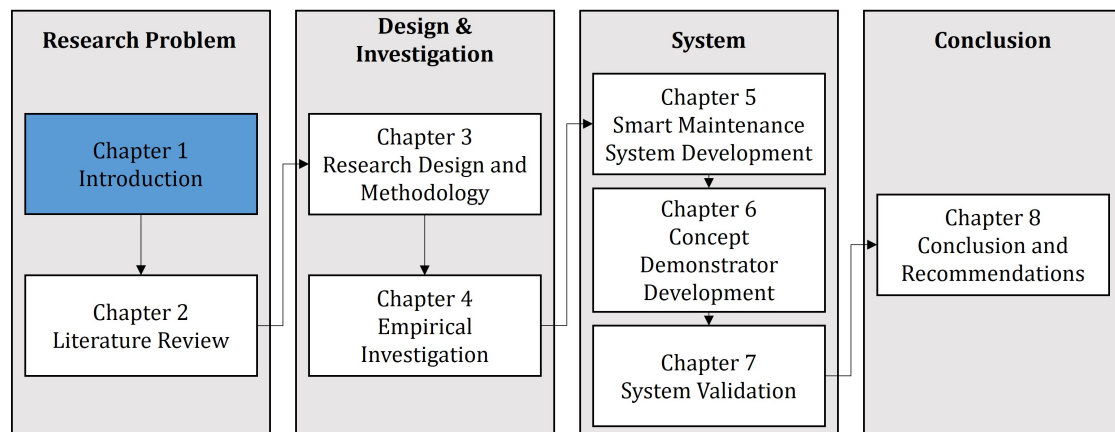

The objective of this chapter is to introduce the research undertaken in this thesis. This chapter commences with the background and rationale of the research, which leads to the research problem and the research questions. The definition of the research objectives follows. After this, the research methodology and design, ethical considerations, limitations and delimitations, as well as the contributions, are addressed. The chapter concludes with the outline of the chapters in this thesis.

## 1.1 Background and Rationale of the Research

Industry 4.0 is a paradigm shift in how we organise, manage and approach business (Winter, 2020). The world today is experiencing the fourth industrial revolution. This is more commonly known as Industry 4.0, which aims to transform industry through digital transformation and the implementation of new technologies (Postelnicu and Calea, 2019). The feature that distinguishes the Fourth Industrial Revolution is the intelligent networks based on Cyber-Physical System (CPS) (Amaral *et al.*, 2017). CPSs are engineered and physical systems that can be controlled, monitored, and coordinated by computing and communication systems (Amaral *et al.*, 2017).

The Internet of Things (IoT) is an important enabler of Industry 4.0 due to it being responsible for the interconnected networks, which allow device-to-device communication (Postelnicu and Calea, 2019). IoT usually takes advantage of the internet and allows network communication without human or computer interfaces (Budakoti, 2018). With IoT, objects are permitted to become interconnected and smart (Fan *et al.*, 2014). The combination of CPS, IoT, and the internet of systems make Industry 4.0 possible and smart factories a reality (Marr, 2018). As machines and factories become smarter, their access to more data increases, allowing the overall efficiency and productivity of factories to improve while waste generation is minimised.

In industry today, organisations realise the importance of taking better control of their approach toward the implementation of maintenance and maintenance practices. According to Patil *et al.* (2022, p. 676), executive management of companies has started to align maintenance with strategic objectives to ensure equipment availability, safety, and quality products. It has been reported that 57% of all European organisations have adopted a lean maintenance philosophy and another 20% plan to follow the same strategy (Beker *et al.*, 2017). At least 77% of European organisations are focused on a management concept with continuous improvement included at its core, making it a good strategic decision to find ways to improve maintenance constantly (Beker *et al.*, 2017).

Maintenance allows companies to maintain their resources while controlling time and costs to ensure their assets are operating at maximum efficiency with minimal downtime (Patil *et al.*, 2022). An effective maintenance management plan can have a noteworthy contribution to the long-term success of a company. Malfunctioning assets and frequent breakdowns have costly financial implications for any company (Kumar *et al.*, 2013). The common objective of most maintenance management plans is to analyse the operation of the company's assets and identify the best practices to ensure stable operation of assets and minimise unplanned downtime (Trout, 2021). The management of maintenance has improved over time to systems such as a Computerised Maintenance Management System (CMMS) (Garg, 2006). With further development, IoT makes it possible for companies to use intelligent maintenance software to collect data and constantly monitor the condition of assets to strive towards making smarter maintenance decisions (Trotter *et al.*, 2018).

With the arrival of Industry 4.0, a problem that has appeared is the transformation of maintenance into smart maintenance (Rakyta *et al.*, 2016). Smart maintenance can be conceptually defined as the organisational design for managing maintenance of companies in environments with pervasive digital technologies (Bokrantz *et al.*, 2019). The aim of smart maintenance is to achieve effective and efficient decision-making and responsiveness to internal and external elements (Bokrantz *et al.*, 2019). Regardless of the level of maintenance practices in an organisation, systematic development of the management of maintenance is required (Rakyta *et al.*, 2016). All equipment wears down as usage increases over time, resulting in the deterioration in its condition as well as decreasing performance (Rakyta *et al.*, 2016). After a certain time of usage, equipment becomes more susceptible to failure (Rakyta *et al.*, 2016). Maintenance practices at an organisation can be continuously improved through a proactive approach. For the successful implementation of a proactive approach to smart maintenance, it is necessary to introduce appropriate management practices in the area of maintenance in a company (Rakyta *et al.*, 2016).

In the inner city public bus transport service industry, the constant need exists to provide trouble-free and effective transport every day to countless daily commuters (Neethling, 2021). The International Association of Public Transport (UITP) estimates that about 80% of all passengers using public transport worldwide are transported by buses (Sanches *et al.*, 2019). The reliable functioning of inner city public bus services contributes to the effective flow and movement of people within a city, which is an important aspect of the successful operation of any city. Buses continue to be the most widely used solution for cities to achieve sustainable urban development (Sanches *et al.*, 2019).

Tubis and Werbinska-Wojciechowska (2015, p. 1061) found that managers have a lack of information support in maintenance decision-making at passenger transport enterprises in cities. The large diversity and high complexity of the operated and maintained means of transport result in maintenance managers not having the ability to independently gather and analyse data required for maintenance planning (Tubis and Werbinska-Wojciechowska, 2015). This supports the idea that there is potential for the implementation of improved process controlling in the field of maintenance management at inner city public bus services. The primary objectives of introducing a system for improving bus maintenance are to maximise reliability, effectively utilise maintenance crews and facility time (Haghani and Shafahi, 2001).

Advanced predictive maintenance systems are available to reduce downtime and fleet management costs for companies with fleets consisting of expensive vehicles (Killeen, 2020). These systems are typically costly and require multiple phases, such as designing, implementing, and testing for individual clients that can be time-consuming. Due to this, organisations that do not want to invest a large amount of capital in such a system continue with their basic maintenance strategies (Killeen, 2020). In recent years, with technological advances in industry, the software and hardware used to monitor the health status of vehicles have become more affordable and compact (Killeen, 2020). This allows for cheaper and simpler systems to be designed to implement smart maintenance and enhance fleet management (Killeen, 2020).



Most large commercial vehicles are equipped with a Controller Area Network (CAN), which allows their different systems to communicate with each other to enable smooth operation and self-diagnostics (Massaro *et al.*, 2020). CAN messages are used in automotive applications to communicate state information, also known as signals, between the different Electronic Control Units (ECUs) of a vehicle (Davis *et al.*, 2007). Most large commercial vehicles are not connected to the internet, which means the sensor data remains unexploited (Killeen, 2020). Thus, there is an opportunity to utilise the unexploited data to improve maintenance decision-making through implementing a system that employs Industry 4.0 technologies. Connecting vehicles by installing sensors creates insight into the health status of a vehicle and its parts, while assisting with the identification of specific faults (Dhall and Solanki, 2017).

The purpose of condition monitoring is to focus on individual pieces of equipment, replace equipment at certain intervals, and inspect it at certain intervals (Galar *et al.*, 2017). To apply condition monitoring to a passenger bus involves the combination of technical and economic actions to achieve the goal of high availability at reasonable cost (Galar *et al.*, 2017). The utilisation of IoT and microcontroller technologies allow for automatic systems to predict fleet health and maintenance (Hussain *et al.*, 2020). Some different frameworks have been proposed for decision-making processes in bus fleet management (Sanches *et al.*, 2019).

Motivating the preference of a system, one has to reflect on what is meant by a framework, a model, and a system. A framework is a line that conceptually connects and gives meaning to concepts (Maxwell, 1996). A framework is also seen as a network of interconnected concepts that provide a comprehensive understanding of a phenomenon or phenomena (Tamene, 2016). When using variables or factors, the term model should be employed (Jabareen, 2009). The approach to creating a model is about abstracting it from a real or proposed system (Robinson *et al.*, 2010). Furthermore, a system is defined as a “complex of interacting elements” (von Bertalanffy, 1968). All definitions of a system involve a collection of units and their interrelationships (Harary and Batell, 1981). The underlying structure

of a system is a nested graph laying out the nested network formed by a system, as expressed by Harary and Batell (1981, p. 32). The discussion reinforces that a system is preferred for this study, due to it being a more suitable approach to aligning maintenance functions, elements, and technologies.

The background discussion indicates that maintenance practices at inner city bus services are not up to date with what is available in the newest developments that involve Industry 4.0 technologies. It is evident that there are smart maintenance and Industry 4.0 technologies available that can be utilised to minimise downtime and ensure the reliability of buses in inner city public bus services.

## 1.2 Research Problem Statement and Questions

The problem is the maintenance approaches and systems that are currently in use at inner city public bus services are based on previous technological and industrialisation methods. Smart maintenance and Industry 4.0 technologies can be used to optimise maintenance in this sector to make the transport more reliable and save unnecessary expenditures. The defined research problem leads to a set of research questions that require investigation. Table 1.1 sets out the primary research question and secondary research questions that are investigated in this study.

**Table 1.1:** Research questions of thesis

<b>Primary</b>	<b>How can a smart maintenance system be developed for inner city public bus services through related Industry 4.0 technologies?</b>	<b>Chapters 2 &amp; 5</b>
Secondary 1	What Industry 4.0 and smart maintenance systems are available to improve maintenance of inner city buses?	Chapter 2
Secondary 2	What are the operational parameters and systems of inner city buses which affect reliability?	Chapters 2 & 4
Secondary 3	How can the functionality of the developed smart maintenance system for inner city bus services be validated?	Chapters 6 & 7

The secondary research questions in Table 1.1 require answering to be able to answer the primary research question. The opportunity exists to lay out a smart maintenance system for inner city public bus services. The implementation of a smart maintenance system only makes sense if it is financially and practically feasible to do so. A successful smart maintenance system is going to strive to optimise the maintenance processes and propel the drive towards Industry 4.0. The results of the implementation of the smart maintenance system should include the improvement of asset life, the reduction in downtime and breakdowns, as well as the minimisation of unnecessary maintenance expenditures.

### 1.3 Research Objectives

The research objectives are derived from the research questions. The research objectives of this study are presented in Table 1.2. In the table it is indicated which research question each objective is associated with as well as in which chapter each objective is addressed. The objectives in Table 1.2 have to be reached to answer the accompanying research questions of this thesis.

**Table 1.2:** Objectives of thesis

	<b>Objective</b>	<b>Question</b>	<b>Chapter</b>
a	Investigate Industry 4.0 technologies and how it supports smart maintenance.	Secondary 1	2
b	Investigate existing smart maintenance approaches for transportation systems.	Secondary 1	2
c	Investigate the factors influencing the degradation of the reliability of a bus.	Secondary 2	2 & 4
d	Identify the key components of the buses that are responsible for most of the downtime.	Secondary 2	4
e	Investigate how the unit life of the key components can be improved.	Secondary 2	2 & 4
f	Develop a smart maintenance system for inner city buses.	Primary	5 & 6
g	Validate the smart maintenance system with a concept demonstrator in Industry.	Primary & Secondary 3	7

## 1.4 Research Methodology and Design Overview

The research conducted in this thesis is empirical in nature. The type of research in this study is a *mixed method exploratory sequential* design. This type of research consists of qualitative and quantitative data collection and analysis phases, as shown in Figure 1.1. The findings of a comprehensive literature review are combined with the results and feedback from online interviews to develop a smart maintenance system. The system validation is done in the form of a case study with an industry partner.

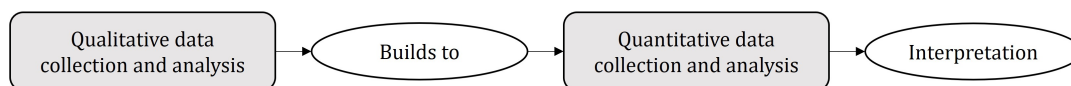

**Figure 1.1:** The exploratory sequential design (Adopted from Creswell and Creswell, 2018, p. 69)

## 1.5 Ethical Considerations

The Faculty Ethics Screening Committee of Stellenbosch University requires that ethical clearance be obtained by signing a consent form between an online interviewee and the principal investigator. This is due to the fact that, during the study, online interviews are conducted to obtain input from representatives of bus services. The data might not necessarily be sensitive or person-related information, but it is good practice to file a consent form as a safety measure.

## 1.6 Limitations and Delimitations

In research, it is necessary to state the limitations and assumptions regarding the research. The study focuses on the smart implementation of maintenance practices and processes for inner city public bus services to enable them to maintain their

bus fleets more effectively.

During the course of the research, no in-person or face-to-face interviews with prospective interviewees are planned. The limitation of the validation phase is that the system can only be partially implemented at one inner city public bus service to test the effectiveness and generalisation of the system. The system can only be partially implemented at an industry partner due to their operations being ongoing and a new approach to maintenance cannot be implemented on their full fleet.

## 1.7 Contributions

It is important to state who benefits from the outcome of this research study. The contributions are as follows:

- a) The main beneficiaries of this study are inner city public bus transport services that will be able to make use of the generic smart maintenance system to improve their maintenance practices.
- b) The residents of any city where the system might be implemented will benefit from the reliable operation of inner city public bus transport services.
- c) The industry partner benefits from this study due to the fact that the smart maintenance system that is developed in this study is tested with a percentage of their bus fleet as part of the system validation phase.
- d) The ESB Business School in Reutlingen (Germany) benefits from this study because the research is conducted in partnership with them. This contribution is valid due to the aim of developing a generic smart maintenance system that is also applicable to inner city public bus services in Germany.

## 1.8 Chapter Outline

This section discusses the structure of the thesis by setting out the chapter outline. The research methodology is used as the baseline to define the contents of the different chapters. The chapter outline is graphically depicted in Figure 1.2.

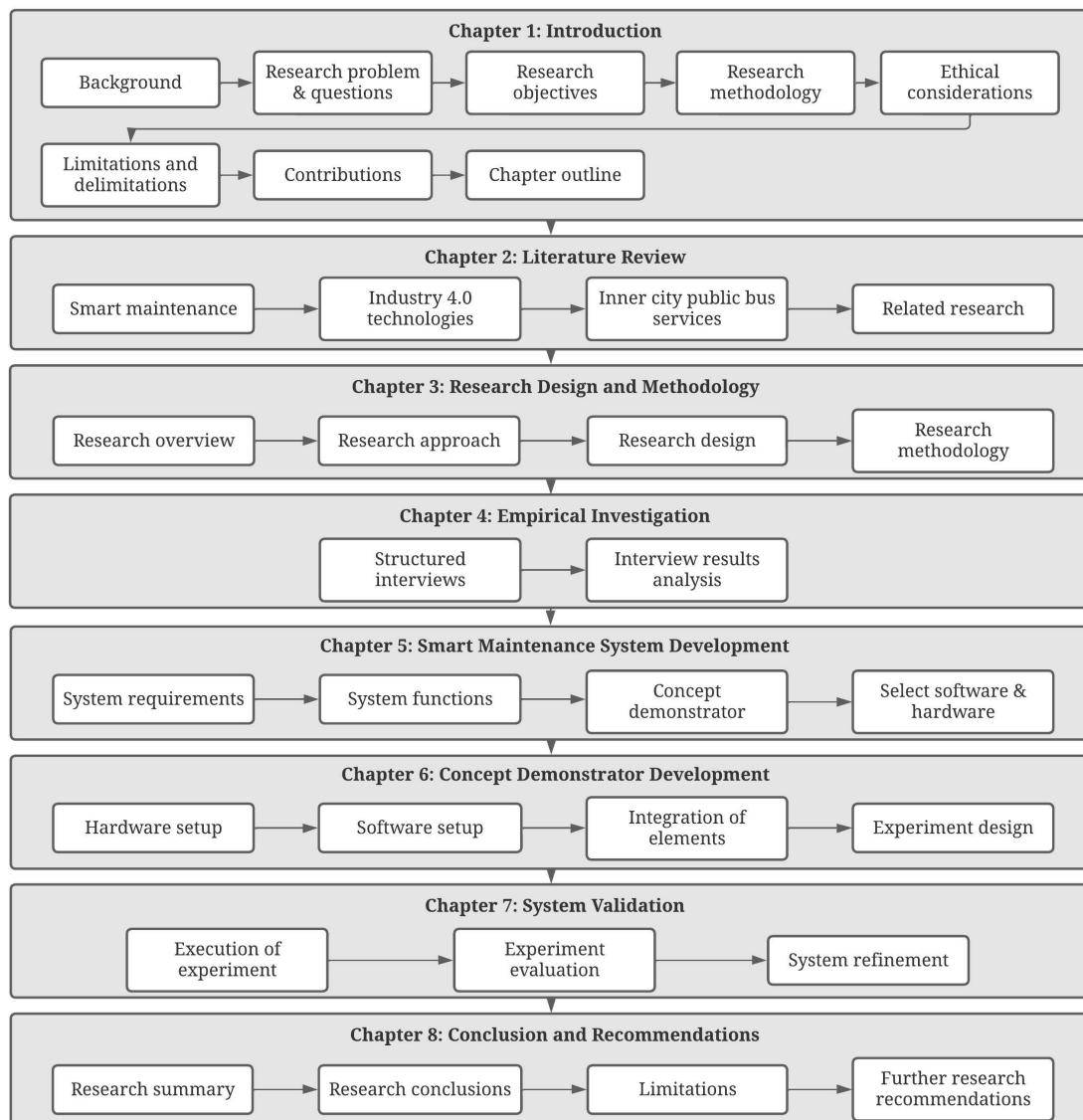

Figure 1.2: Chapter outline

The chapter outline follows a logical order, starting with Chapter 1 and Chapter 2 as the introduction and the literature review, respectively. The research design and methodologies are covered in Chapter 3. Online interviews are set up and conducted as part of the empirical investigation of Chapter 4. In Chapter 5, the smart maintenance system is set out and designed. The concept demonstrator is developed and constructed in Chapter 6. System validation of the smart maintenance system takes place as part of Chapter 7. The thesis is concluded with Chapter 8 where the conclusions from the research are stated and recommendations are made for future continuation of the research.

## 1.9 Chapter Summary

This chapter introduces the background and the rationale of the research. The research problem is stated and from the research problem, the research questions are derived, as well as the corresponding research objectives. Afterwards, the research methodology and design, ethical considerations, limitations and delimitations, and the contributions are outlined. Finally, the outline of the thesis is covered.

# Chapter 2

## Literature Review

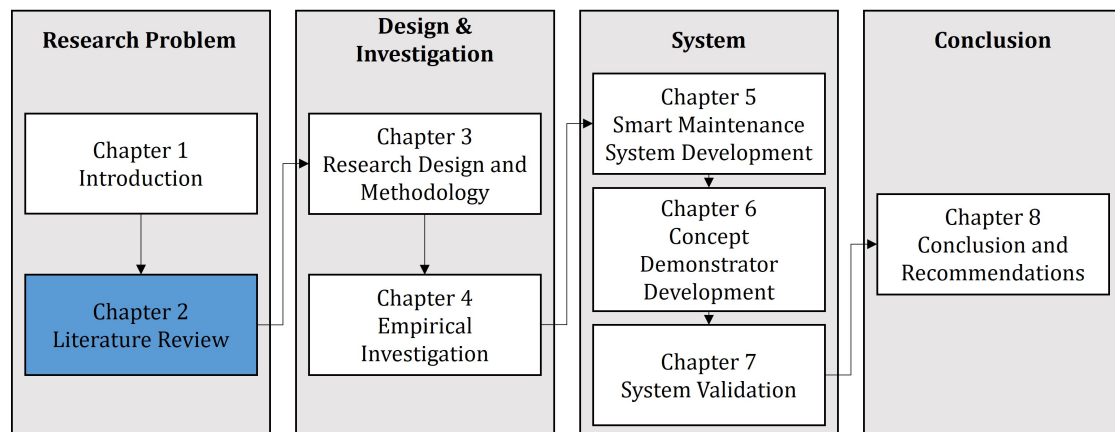

The objective of this chapter is to review the relevant literature relating to the problem statement and objectives. This chapter includes sections that define maintenance, identify relevant Industry 4.0 technologies that support smart maintenance, discuss inner city public bus services, and investigate prognostics and health management. Related research is also examined and included in the literature review.



## 2.1 Maintenance

Maintenance has become increasingly important as industry is experiencing digitalisation and new advances in technologies. In this section, maintenance is defined and different maintenance strategies are identified and discussed. The requirements and outline of a smart maintenance system are presented and overviewed.

### 2.1.1 Definition of Maintenance

Maintenance provides an essential contribution to the dependability of equipment (DINEN13306, 2018). The German Institute for Standardisation (DINEN13306, 2018) describes maintenance according to the following definition:

*Maintenance is the “combination of all technical, administrative and managerial actions during the life cycle of an item intended to retain it in, or restore it to, a state in which it can perform the required function”.*

Generally, maintenance can be subdivided into four main divisions, as shown in Figure 2.1. It is necessary to understand each of the subdivisions of maintenance to gain a better understanding of maintenance itself.

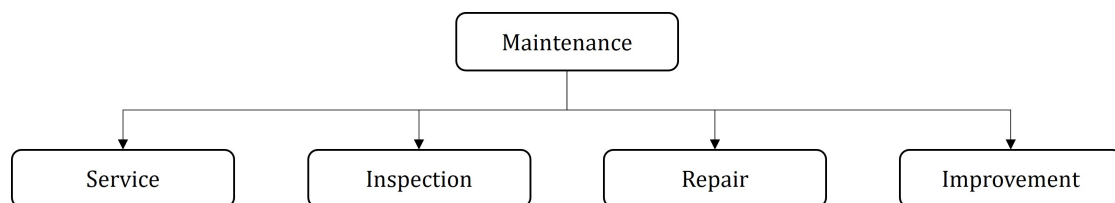

**Figure 2.1:** Maintenance subdivisions (Adopted from DIN31051, 2019, p. 12)

*Service* involves the “measures taken to delay the reduction of the existing wear margin” (DIN31051, 2019). The wear margin describes the range for the functional fulfilment of an asset. The reduction of the wear margin is illustrated in Figure 2.2. The largest wear occurs directly after manufacture and decreases with time. As

the wear margin decreases with time, a wear limit is reached below which smooth operation cannot be guaranteed. Maintenance aims to prolong the time between the initial state after manufacture and the wear limit.

*Inspection* is the “examination for conformity by measuring, observing, or testing the relevant characteristics of an item” (DINEN13306, 2018). During inspection, a comparison is made between the initial and actual conditions, which should always take place under constant operating and environmental conditions.

*Repair* can be described as “physical action taken to restore the required function of a faulty item” (DINEN13306, 2018). Repair can be conducted by repairing or replacing the faulty item (Struntz, 2012). The furthestmost point on the right-hand side of the graph in Figure 2.2 illustrates the repair of an item to the same condition as the initial state after manufacture.

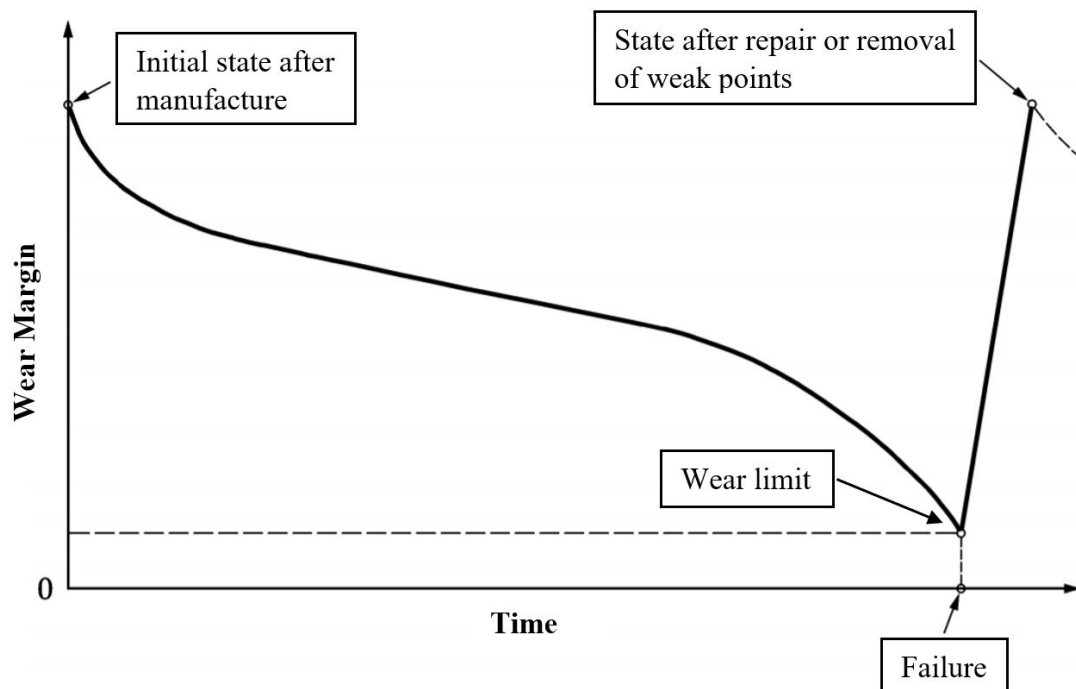

Figure 2.2: Wear margin (Adopted from DIN31051, 2019, p. 8)

*Improvement* is the “combination of all technical, administrative and managerial actions, intended to ameliorate the intrinsic reliability and/or maintainability and/or safety of an item, without changing the original function” (DINEN13306, 2018). The elimination of a weak point is crucial to improve functional reliability (Matyas, 2016). A requirement for improving a weak point is technical and economic feasibility (Struntz, 2012).

### 2.1.2 Maintenance Strategies

A maintenance strategy is a “management method used in order to achieve the maintenance objectives” (DINEN13306, 2018). According to DINEN13306 (2018, p. 6), any maintenance management has the responsibility to define its maintenance strategy according to the following objectives:

- “Ensure the availability of the item to function as required, at optimum costs”.
- “Consider the safety, the persons, the environment, and any other mandatory requirements associated with the item”.
- “Consider any impact on the environment”.
- “Uphold the durability of the item and/or the quality of the product or service provided considering costs”.

A maintenance strategy involves a mix of maintenance policies and maintenance techniques, which vary between organisations (Velmurugan and Dhingra, 2015). The selection of the best sustainable maintenance strategy depends on numerous elements, such as the nature of the organisation, the maintenance goals, the equipment that is maintained, the flow of work, and the working environment (Velmurugan and Dhingra, 2015). The reference model in Figure 2.3 gives an overview of the development of maintenance strategies. The respective maintenance strategies are discussed in more detail in the following sections.

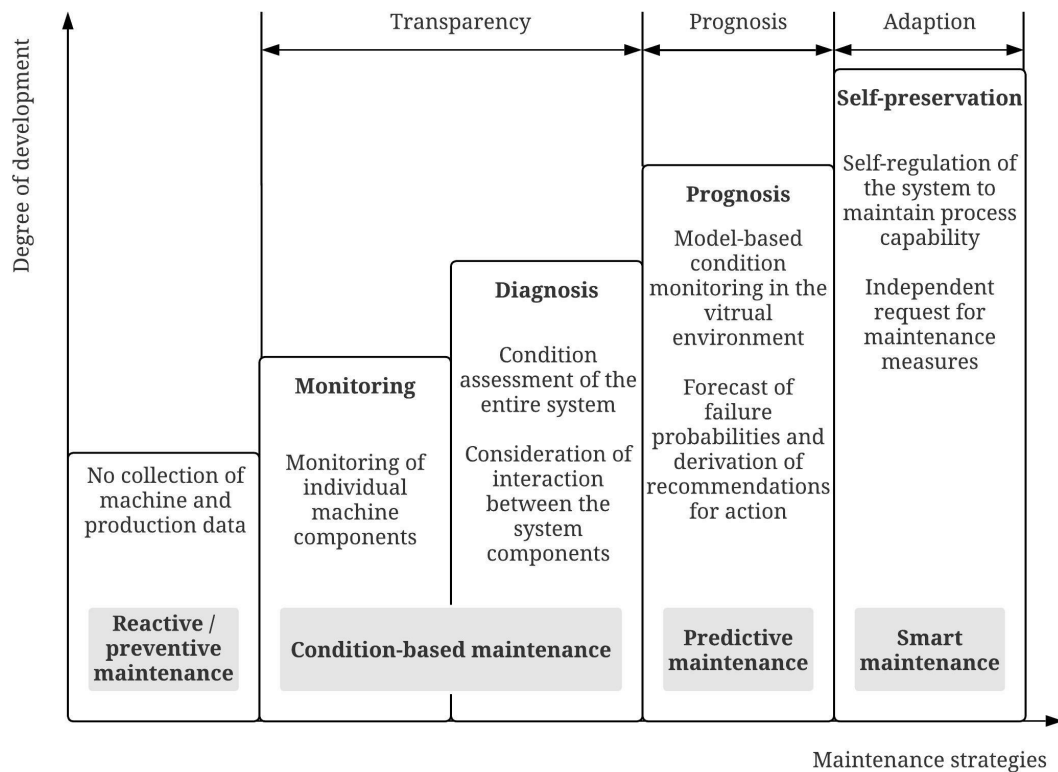

**Figure 2.3:** Reference model for the development of maintenance strategies (Adopted from Ermonts-Holley, 2016)

### 2.1.2.1 Reactive Maintenance

When a reactive maintenance strategy is implemented, equipment is allowed to run to failure before it is repaired or replaced (Swanson, 2001). There is no pre-determined plan in place to service equipment to prevent failures in the future. Reactive maintenance allows an organisation to minimise the size of maintenance crews and the amount of money spent to keep all their equipment operational (Swanson, 2001). However, this maintenance strategy comes with disadvantages that can include unpredictable operation, increased levels of waste output, and higher maintenance costs to repair total failures (Swanson, 2001). In modern industry, reactive maintenance is only used in exceptional cases when the equipment in question is either redundant or of minor importance (Matyas, 2002).

### 2.1.2.2 Preventive Maintenance

Preventive maintenance is “maintenance carried out intended to assess and/or mitigate degradation and reduce the probability of failure of an item” (DINEN13306, 2018). This type of maintenance depends on the estimated likelihood that the equipment has a specified interval within which it will fail (Swanson, 2001). The specified intervals can be measured as cycles, kilometres, time, etc. to determine the correct moment to implement maintenance (Jimenez *et al.*, 2020). Benefits of preventive maintenance include the reduced probability that equipment will break down, and it extends the life of equipment (Swanson, 2001). The disadvantage of this type of maintenance is that operations have to be halted at scheduled intervals in order to perform maintenance activities (Swanson, 2001). In preventive maintenance, the existence of faults is frequently unknown, which may lead to the replacement of components with remaining useful life that could have been utilised, which may be costly (Jimenez *et al.*, 2020).

### 2.1.2.3 Condition-based Maintenance

Some organisations still utilise Time-based Maintenance (TBM) strategies that are basically preventive maintenance, which can lead to the substantial wastage of remaining useful life if the equipment is still in reasonable condition (de Jonge *et al.*, 2017). Due to advancements in technologies, it has become easier to monitor, store, and analyse equipment conditions resulting in Condition-based Maintenance (CBM) strategies gaining popularity (Jardine *et al.*, 2006). CBM is “preventive maintenance which includes assessment of physical conditions, analysis and the possible ensuing maintenance actions” (DINEN13306, 2018). CBM can also be viewed as a type of preventive maintenance that is more effectively scheduled and ideally performed just before failure (de Jonge *et al.*, 2017).

According to Veldman *et al.* (2011, p. 42), the execution of CBM generally consists of the following four phases:

1. *Data collection*: The relevant data is collected using different methods, such as vibration monitoring, temperature monitoring, oil analysis, and using process control systems. The most common types of data are process data and failure data (Veldman *et al.*, 2011).
2. *Data analysis*: The data analysis phase is where the data is cleaned and processed.
3. *Decision-making*: Decisions are made based on the collected data and the data analysis. The decisions may lead to operating routines being changed or the direct implementation of maintenance.
4. *Implementation*: After strategic decisions have been made, an intervention is planned and executed. Evaluations are conducted as required.

It is only be feasible to implement CBM when the relative benefit outweighs the effort and financial implication to implement CBM during the entire life cycle of equipment (de Jonge *et al.*, 2017). Organisations that are considering the implementation of CBM should recognise the risks related to the lack of experience (de Jonge *et al.*, 2017).

#### 2.1.2.4 Predictive Maintenance

Predictive maintenance is “condition-based maintenance carried out following a forecast derived from repeated analysis or known characteristics and evaluation of the significant parameters of the degradation of the item” (DINEN13306, 2018). The movement towards predictive maintenance practices in industry can minimise costs by up to 30% and reduce breakdowns by up to 75% when compared to preventive maintenance (Matyas *et al.*, 2017).

The goal of predictive maintenance is to improve maintenance activities, performance, safety, and reliability (Adams *et al.*, 2017). The two main fields of predictive maintenance are diagnostics and prognostics (Jimenez *et al.*, 2020). The aim of diagnostics is to detect faults, determine the root cause of faults, and determine the current health condition of equipment to prevent unforeseen failures

(Jimenez *et al.*, 2020). Prognostics is the prediction of the health status of equipment being monitored (Killeen *et al.*, 2019; Ermonts-Holley, 2016).

Numerous prognostic approaches have been developed that range from simple historical failure rate models to physics-based models (Byington *et al.*, 2002). Figure 2.4 illustrates the hierarchy of different prognostic approaches in relation to their applicability, cost, and accuracy.

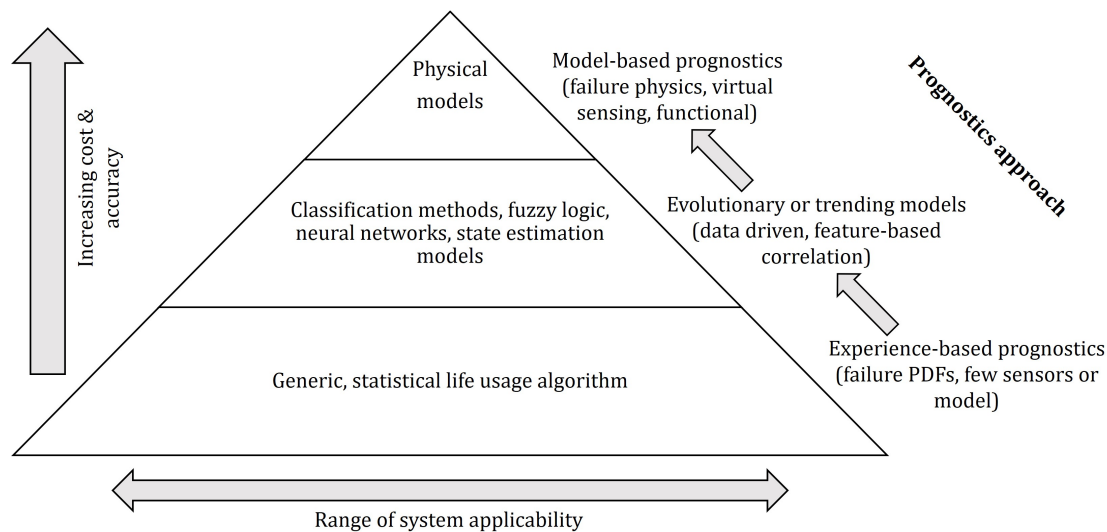

**Figure 2.4:** Hierarchy of prognostic approaches (Adopted from Byington *et al.*, 2002, p. 2815)

The accuracy and development costs of the models increases as the prognostic approaches move up the hierarchy in Figure 2.4. The experience-based model is the least complex, only utilising a few sensors and is designed for a broad range of applications. Contrastingly, in the physics-based model, the specific case and conditions have to be specified precisely for the prediction of the remaining useful life of components (Byington *et al.*, 2002).

### 2.1.2.5 Smart Maintenance

Currently, no clear definition for smart maintenance is available in literature. A definition developed by Henke *et al.* (2019, p. 11) for smart maintenance is described as follows:

*Smart maintenance is “learning-orientated, self-regulated, intelligent maintenance with the objective of maximising the technical and economic effectiveness of maintenance measures taking into account the respective existing production system by using digital applications”.*

Smart maintenance has four underlying dimensions, namely: data-driven decision-making, human capital resource, internal integration, and external integration (Bokrantz *et al.*, 2019). The four underlying dimensions of smart maintenance can be defined as:

- *Data-driven decision-making*: Is about making decisions to a certain extent based on information extracted from data. There are four distinct categories in the process of extracting real value from raw data, namely: data collection, data quality, data analysis, and decision-making (Bokrantz *et al.*, 2019). It is not possible to base decisions on data that does not exist, there is no existing algorithm that can transform poor data into usable knowledge, and no useful knowledge can be extracted from data without doing an analysis. Data-driven decisions consist of decision automation and decision augmentation (Bokrantz *et al.*, 2019). Decision automation is where decisions are made by advanced algorithms that would have previously been made by humans. Decision augmentation is the integration of algorithms and human judgement. An overview of the factors influencing data-driven decision-making is shown in Figure 2.5.



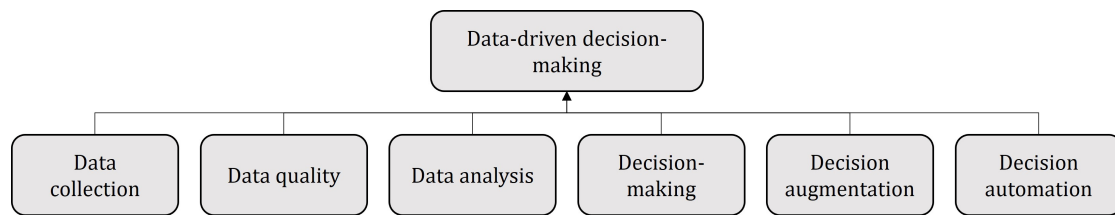

**Figure 2.5:** Data-driven decision-making factors (Adopted from Bokrantz *et al.*, 2019, p. 7)

- *Human capital resource*: An important factor for the success of smart maintenance is to overcome the gap between technology and skills. According to Henke *et al.* (2019, p. 15), structural change is happening from labour-intensive to knowledge-intensive business areas. The latest advances in technologies and digitalisation have resulted in maintenance tasks becoming increasingly complex (Bokrantz *et al.*, 2019). Employees performing maintenance functions require the right skill set to execute advanced maintenance techniques (Velmurugan and Dhingra, 2015). Advancements in technologies put new skill requirements on employees to become more qualified (Bokrantz *et al.*, 2019). The new skill requirements can be divided into six categories, as shown in Figure 2.6.

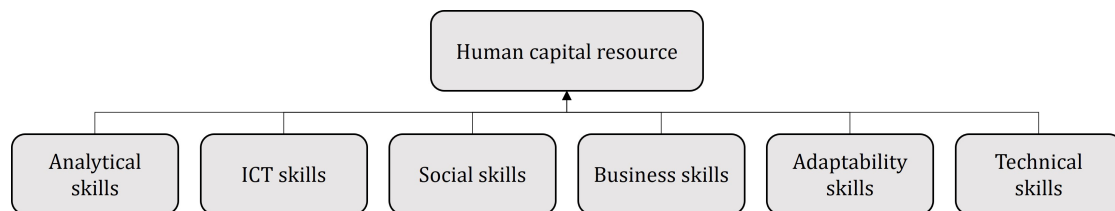
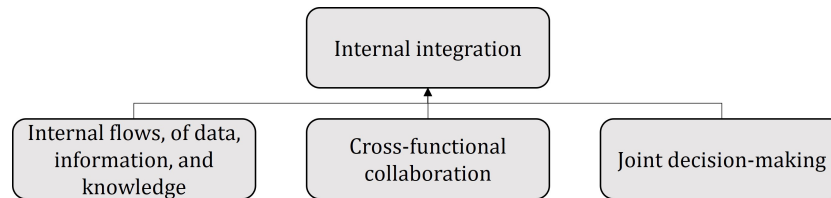

**Figure 2.6:** Six categories of human capital resource (Adopted from Bokrantz *et al.*, 2019, p. 7)

Human capital will remain a critical value-creating resource and will not be terminated by advancements in technologies (Bokrantz *et al.*, 2019).

- *Internal integration*: Smart maintenance has a distinctive characteristic that involves the relation of the maintenance function to the internal plant organ-

isation (Bokrantz *et al.*, 2019). The incorporation of maintenance into production and the rest of the organisation can be divided into three categories, as shown in Figure 2.7.



**Figure 2.7:** Internal integration factors (Adopted from Bokrantz *et al.*, 2019, p. 7)

Establishing links between different functions within an organisation allows the maintenance function to be incorporated in the transparent exchange and utilisation of diverse sources of data, information, and knowledge. Cross-functional collaboration involves the improved coordination between different functions within an organisation. Joint decision-making is when data is shared to achieve a common understanding. Consensus on data and decisions makes it possible to plan and synchronise maintenance with other processes within an organisation (Bokrantz *et al.*, 2019).

- *External integration:* This is the extent to which the maintenance function forms part of the consolidated inter-organisational environment (Bokrantz *et al.*, 2020). External integration consists of four dimensions, as shown in Figure 2.8.

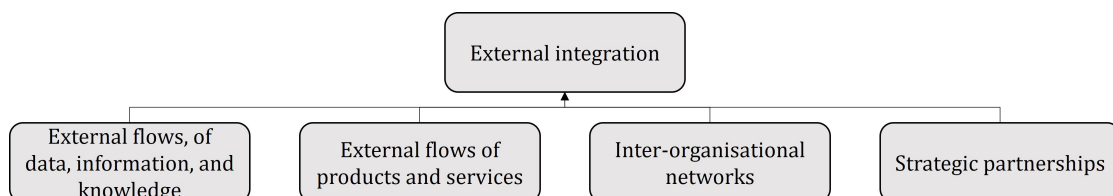

**Figure 2.8:** External integration factors (Adopted from Bokrantz *et al.*, 2019, p. 7)

External integration extends links to the external environment to allow for the transparent exchange and utilisation of diverse sources of data, information, and knowledge with external parties. The external links can be networks of interrelated firms and partners that can include processes, people, and technology. Advancements in Information and Communications Technology (ICT) have made it possible for maintenance functions to be more closely integrated with external parties (Bokrantz *et al.*, 2020).

### 2.1.3 Smart Maintenance System

A planning system that manages maintenance items, schedules, and controls maintenance tasks is the foundation of a smart maintenance system. The Information Technology (IT) system assists maintenance personnel in the planning and execution of maintenance tasks (Lucke *et al.*, 2017). Some of the other related functions that may be incorporated are spare parts and ordering, maintenance control, and maintenance personnel management. According to Lucke *et al.* (2017), current maintenance planning systems have a number of disadvantages that are outlined below:

- Additional functions are frequently still integrated in distinct IT systems, and they are commonly application-specific, resulting in additional expenses to link the different interfaces.
- Previous maintenance planning systems lacked the capability to assist maintenance personnel in selecting and deciding on an acceptable maintenance approach.
- Component health and remaining useful life information are usually assessed manually.
- Conducted or planned maintenance operations are not synchronised with production planning.

The cause of the deficiencies is frequently linked to the current scenario, in which all maintenance scheduling deviates and is dynamically rescheduled to be

reactive due to unforeseen machine downtimes. As a result of the above-mentioned deficiencies, future maintenance planning systems need to meet the following requirements (Lucke *et al.*, 2017):

1. Support in the selection of the maintenance strategy: Maintenance object-related information and its relevance in the value-added network should be considered when choosing a maintenance plan for machines, systems, and components.
2. Improvement of the utilisation of machine assemblies and components: Wear models and load-dependent remaining service life assessments can be incorporated as a partial function of a “smart component”, allowing it to be utilised in full and replaced in a timely manner.
3. Accelerated maintenance planning:
  - By consistently connecting maintenance planning modules to cyber-physical machines.
  - Improved user assistance to reduce the time it takes to find necessary information.
  - Use planning aids that support an optimised multi-criteria maintenance plan.
4. Increase in planning quality: Utilisation of accurate, trustworthy information that is current and situation-related.
5. Improvement of usability: Provide the necessary information to the maintenance planner to make planning easier.
6. Flexibility of IT systems, reduction of the effort required for networking: Without in-depth specialised knowledge, IT systems for maintenance should be able to adapt to new conditions quickly and effectively.
7. Structure functions modularly that allow for quick adaptation to application-specific scenarios.

These requirements are discussed further in Chapter 4 and given a score according to their rank. Their importance is shown as a percentage in a bar chart in Figure 4.4. The defined requirements result in the architecture of a future maintenance planning system, as shown in Figure 2.9.

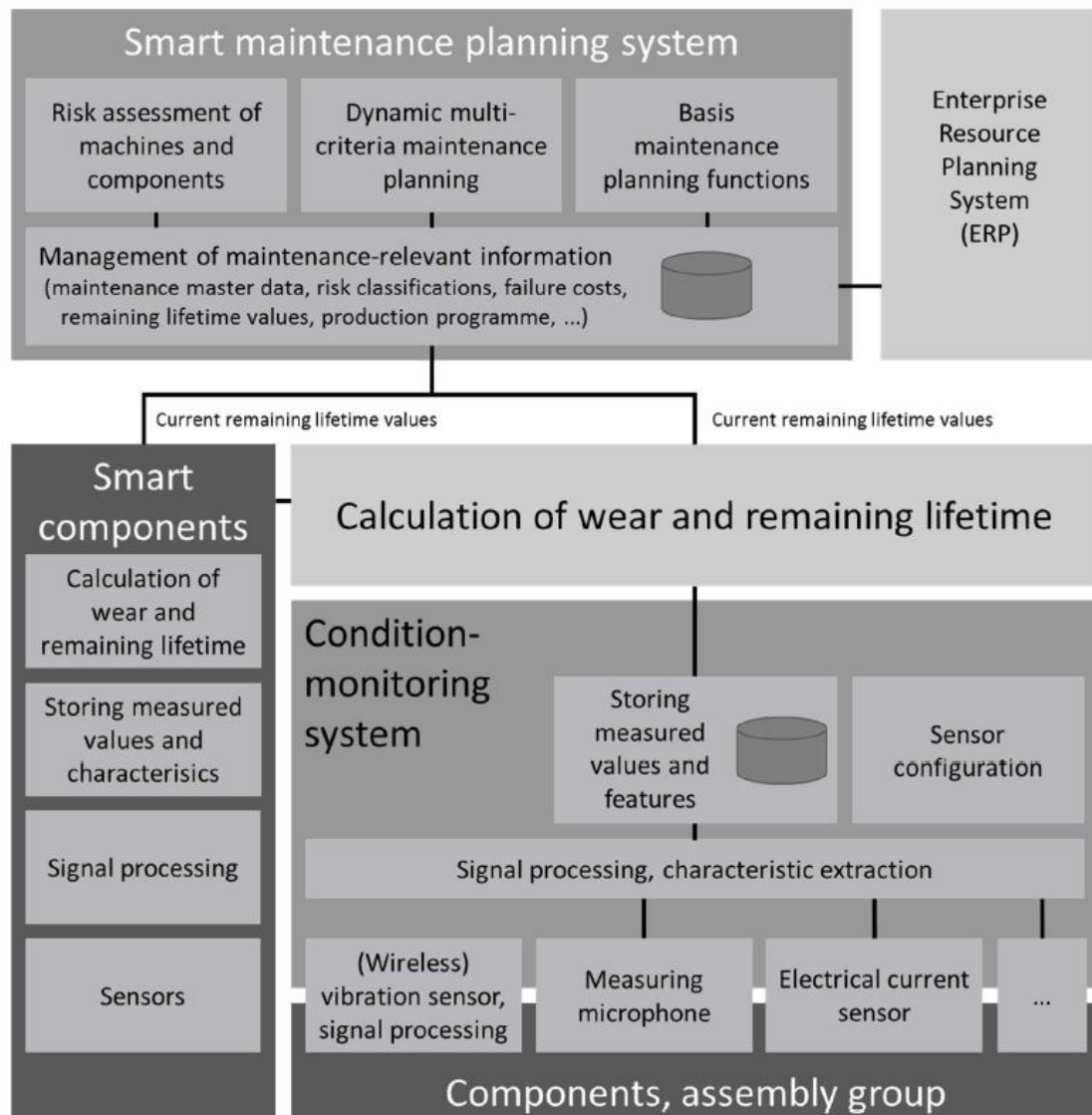

**Figure 2.9:** Architecture of a future maintenance planning system (Adopted from Lucke *et al.*, 2017, p. 83)

The aim is to assist maintenance managers in optimising the maintenance strategy and planning by considering the remaining useful life of the monitored key components or assemblies. The remaining useful life values are derived from a number of sources, such as smart components or a downstream calculation when utilising a condition monitoring system. The basic method for implementing a smart maintenance system can be described by the following six steps (Kinz and Biedermann, 2016):

1. Identifying key components in equipment and plants.
2. Technology validation for condition monitoring.
3. Analyse the data.
4. Identifying and assessing cause-and-effect relationships.
5. Failure prognostics methods.
6. Better variety of maintenance strategies.

After gaining an understanding of maintenance and what smart maintenance is, the Industry 4.0 technologies that are able to realise smart maintenance can be investigated.

## 2.2 Industry 4.0 Technologies Supporting Smart Maintenance

In this section, relevant Industry 4.0 technologies that support smart maintenance are discussed to gain an understanding of these technologies. Industry 4.0 is the current trend of automation that includes IoT, CPS, and cloud computing (Ayab *et al.*, 2018). Maintenance analytics depend on the availability of an extensive amount of data from numerous sources (Karim *et al.*, 2016). The large volume of data is referred to as Big Data (Roy *et al.*, 2016). The use of Artificial Intelligence (AI) for predictive maintenance is currently becoming an industry trend (Ochella

and Shafiee, 2019). Big Data, IoT, cloud computing, CPS, and AI are discussed.

### 2.2.1 Big Data and Analytics

In industry today, there is a growing trend towards condition monitoring, prognostics, IoT, Industry 4.0, and cloud computing (Roy *et al.*, 2016). As a result, the extent of data available for maintenance decision-making has increased significantly. The digitalisation of industry provides the ability to collect of a vast amount of data and information from maintenance processes and data sources (Karim *et al.*, 2016).

Big Data can be defined as large volume, high-speed information consisting of structured and unstructured data (Roy *et al.*, 2016). Definitions of Big Data are evolving with the constant technological advances occurring (Gandomi and Haider, 2015). To get a more in-depth understanding of Big Data, it is necessary to define it from another perspective. Big Data can be characterised by the following dimensions (Gandomi and Haider, 2015, p. 138; Karim *et al.*, 2016, p. 219):

1. *Volume*: The volume refers to the magnitude of the data. Storage capacities are continuously increasing that allow for larger data sets to be supported.
2. *Velocity*: The generation rate of data and the speed at which it is processed and analysed.
3. *Variety*: Advances in technology allow organisations to utilise different types of data. The different types of data are structured, semi-structured, and unstructured data.
4. *Veracity*: Addresses the quality and accuracy of the data.
5. *Variability*: The variation of the rates in data flow. Big Data velocity is not always consistent and it experiences variations.
6. *Value*: Data in its original form normally has low value relative to its size. High value can be obtained by analysing large amounts of low-value density data.

All the above-mentioned dimensions are known as the different V's of Big Data. The first three dimensions imply that data comes in large sizes, data is created rapidly, data exists in different structures and can come from various sources. The rest of the dimensions give further insight into Big Data. The dimensions are not independent of each other due to the fact that if one dimension changes, there is an increased likelihood that another dimension will change as well (Gandomi and Haider, 2015).

The potential of Big Data is only extracted when it is utilised to support decision-making. To support evidence-based decision-making, effective processes are required that convert high volumes of rapid pace and diverse data into usable knowledge (Gandomi and Haider, 2015). The process of extracting knowledge from Big Data can be divided into five stages (Labrinidis and Jagadish, 2012). The five stages are shown in Figure 2.10 and form two main process groups: Data management and Analytics.

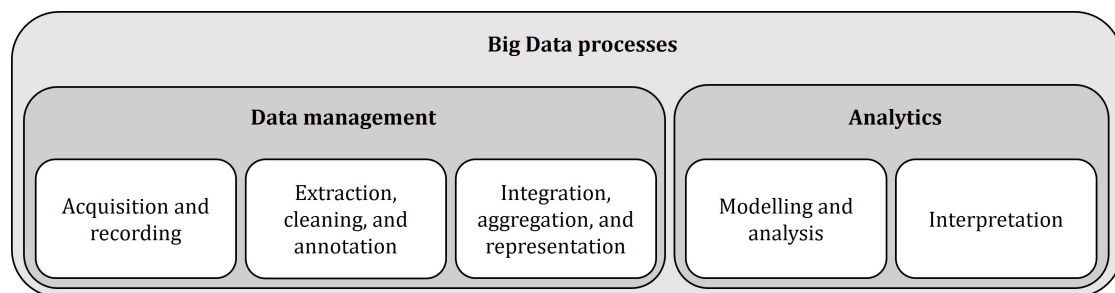

**Figure 2.10:** Processes for extracting insights from Big Data (Adopted from Gandomi and Haider, 2015, p. 141)

Data management entails the processes and technologies that are used to acquire, store, and prepare the data for analysis (Gandomi and Haider, 2015). Analytics are the techniques implemented to obtain insight and intelligence from the data (Gandomi and Haider, 2015).

Most of the existing maintenance strategies are supported by IT that monitors certain measurements, creating large volumes of data (O'Donovan *et al.*, 2015).



Visualising the extensive amounts of data available is important in the decision-making process for continuous maintenance (Roy *et al.*, 2016). Big Data analytics can produce useful information for improved maintenance prediction accuracy by analysing the relationships of service events, component degradation, and component design. Knowledge discovery is an essential aspect of maintenance decision support (Karim *et al.*, 2016). One of the requirements for maintenance knowledge discovery is having accurate data and information available (Karim *et al.*, 2016). It is important to mention that developing a maintenance decision support system based on Big Data increases the complexity of the system (Roy *et al.*, 2016).

### 2.2.2 Internet of Things (IoT)

IoT can be defined as “an intelligent pervasive environment, based on a continuing proliferation of intelligent networks, wireless sensors and massive data centres” (Ayab *et al.*, 2018). The basic vision of IoT is that nearly everything in the physical world can become a computer that is connected to the internet (Ayab *et al.*, 2018).

To ensure the objective of IoT is reached, its environment should be well-organised to allow multiple interconnected devices to operate effectively (Touqeer *et al.*, 2021). The structure of IoT can be analysed to acquire greater insight into this technology. IoT can be divided into the five layers (Datta *et al.*, 2014):

- *Sensing*: Involves the gathering of data and transferring it to a database or cloud. Some IoT devices have limited data storage and sensing useful data for processing is important (Rashid *et al.*, 2020).
- *Network*: This layer consists of communication software that allows different devices to communicate with each other. The primary objective of this layer is to facilitate the transmission of data to end devices, and devices between the end nodes (Touqeer *et al.*, 2021). The transmission path can be wired or wireless via mobile telecommunication and the internet.

- *Storage*: In the storage layer, all the different types of data are stored. This layer can store data using a variety of strategies to satisfy IoT storage requirements.
- *Learning*: Data analytics are performed on the stored data for the purpose of discovering useful knowledge. The location for data analytics is optimised in this layer. The machine learning model for a vehicle should be located on a gateway and fleet-wide analytics should be performed on a cloud (Killeen, 2020).
- *Application*: The application layer is where interfaces are provided to allow users to access the IoT systems and devices. It ensures smart services at high quality (Rashid *et al.*, 2020).

An IoT infrastructure is required in Maintenance 4.0 that allows devices to be wirelessly connected to enable the transmission of data to the maintenance data centre for improved asset management (Jasiulewicz-Kaczmarek and Gola, 2019). Jasiulewicz-Kaczmarek and Gola (2019, p. 94) list five ways that IoT can improve machinery and equipment management:

- *Greater adoption of predictive maintenance*: Predictive maintenance is the primary motivation to apply IoT to improve the management of assets and maintenance strategies.
- *Real-time data analysis*: The availability of all machine data in a virtual network provides the possibility for improved data analysis.
- *Accurate performance metrics*: The system automatically calculates availability, reliability, and other key performance indicators, such as Mean Time Between Failures (MTBF) and Mean Time to Repair (MTTR).
- *Remote assets*: Assets generate their own individual work orders remotely in the CMMS.
- *Recommended repair actions*: Using cloud technology to generate repair actions in real time from failure data.

The suggested measures of how IoT can improve equipment management allow for the implementation of more effective modern maintenance strategies. IoT provides the knowledge for continuous improvement, resource efficiency, and the capability for sustainability (Jasiulewicz-Kaczmarek and Gola, 2019).

### 2.2.3 Cloud Computing

The cloud allows information and computing resources to be accessed from anywhere and also provides virtual centralisation of data and computing applications (Mehdipour *et al.*, 2019). Some organisations move their IT completely to the cloud (Bonomi *et al.*, 2014). Cloud computing offers three basic service models (Alam, 2020):

- Software as a Service (SaaS): Intended for the end users through providing applications.
- Platform as a Service (PaaS): Provides the infrastructure for developers to build up software.
- Infrastructure as a Service (IaaS): Provides development resources such as networking, storage, and computing.

Cloud computing is ideal for optimising resource utilisation, but it is not effective at hosting Big Data applications (Dastjerdi *et al.*, 2016). To overcome the latest challenges with cloud computing, data analytics can be performed at the network Fog or Edge close to where the data is generated to reduce the volume of overhanging data (Yi and Li, 2015). The field of cloud computing has evolved with current trends being Fog computing and Edge computing. These terms are explained in the next sections.

#### 2.2.3.1 Fog Computing

Fog computing can be described as a “paradigm shift that provides limited capabilities such as computing, storing, and networking services in a distributed manner between different end devices and classical cloud computing” (Atlam *et al.*, 2018).

Bonomi *et al.* (2014, p. 170) point out that Fog computing complements the cloud and does not replace it.

### 2.2.3.2 Edge Computing

Edge computing is computation carried out at the edge of the network. The purpose of Edge computing is to “serve as the intermediary between the end users/devices and the cloud, providing processing and storing functionalities to a large number of IoT end devices” (Omoniwa *et al.*, 2018).

## 2.2.4 Cyber-Physical System (CPS)

The Fourth Industrial Revolution is realised through CPS developments, which also made a significant contribution to the establishment of the smart factory (Sinha and Roy, 2020; Henke *et al.*, 2019). CPS involves interconnecting physical objects using local or global data networks (Roy *et al.*, 2016). Connecting assets in the industrial environment to the internet using smart sensors creates a CPS of interlinked machines (Moens *et al.*, 2020). In Figure 2.11, the 5-level CPS structure is presented that provides a guideline for the development and deployment of a CPS.

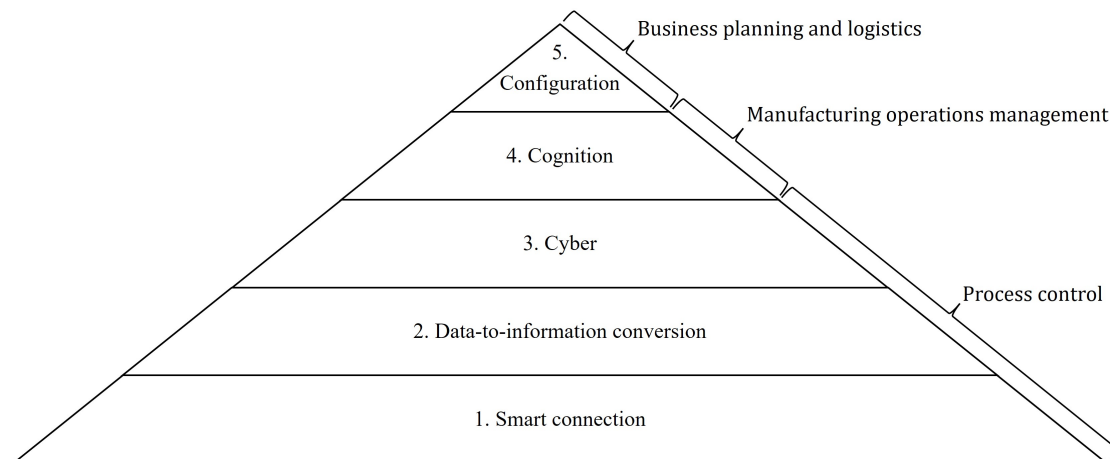

**Figure 2.11:** 5C architecture for industrial Cyber-Physical System (Adopted from Sinha and Roy, 2020, p. 107)

The structure is called the 5C architecture and defines how to establish a CPS from the initial data acquisition and analytics up until final value creation (Lee *et al.*, 2014).

The 5C architecture can be outlined as follows (Lee *et al.*, 2014):

1. *Smart connection*: Acquire accurate and reliable data from machines. Selecting the right sensors is an important consideration.
2. *Data-to-information conversion*: Extract meaningful information from the data. For prognostics and health management, algorithms are specifically developed.
3. *Cyber*: All the information is gathered from the connected machines to create the machine network. Analytics are used to gain insight into the status of machines and allow for the performance of machines to be compared among the fleet.
4. *Cognition*: The acquired knowledge is presented appropriately to enable informed decisions to be taken with regard to optimising maintenance.
5. *Configuration*: This level is where the transition is made from cyberspace back to physical space. The corrective and preventive decisions are applied to the monitored system.

The implementation of CPS is leading industry to improved access to information regarding monitored assets and allows for better control over these assets (Jantunen *et al.*, 2018). Applying CPS in industry has the following benefits (Kamaludin and Mulyanti, 2020):

- Status and condition of equipment can be monitored continuously.
- Can remotely control the function of equipment.
- Works automatically based on algorithms and sensor data.
- Supports service activities such as predictive and preventive maintenance.

- Can perform fault diagnostics from a distance.

The advantages of CPS indicate that it can be a valuable contribution to any organisation. Future maintenance architectures will increasingly utilise CPS and cloud technologies that are the supporting fundamentals of Industry 4.0 (Jantunen *et al.*, 2018). To promote digitalisation and Industry 4.0, the adoption of CPS is an important consideration.

### 2.2.5 Artificial Intelligence (AI)

The field of AI is becoming more popular for various applications in industry today (Ochella and Shafiee, 2019). The goal of AI is to use machines to perceive human-like intelligence to allow for recognition, cognition, classification, and decision-making (Zhang *et al.*, 2020).

Current developments in IoT and AI provide the foundation for the implementation of predictive maintenance in real industrial environments (Liu *et al.*, 2021). The popularity of AI in predictive maintenance is due to the increased availability and accessibility of sensor data of monitored systems (Ochella and Shafiee, 2019). AI has already demonstrated the advantages of intelligent maintenance. Through the use of AI some coal-fired power plants were able to predict failures six to nine months in advance, with an accuracy of 74% (Bughin *et al.*, 2017).

Popular algorithms include Artificial Neural Networks (ANNs), k-nearest neighbours, naive Bayes, and decision trees. In predictive maintenance, ANNs are used more frequently than other algorithms (Ochella and Shafiee, 2019). The different types of AI algorithms are illustrated by Figure 2.12.

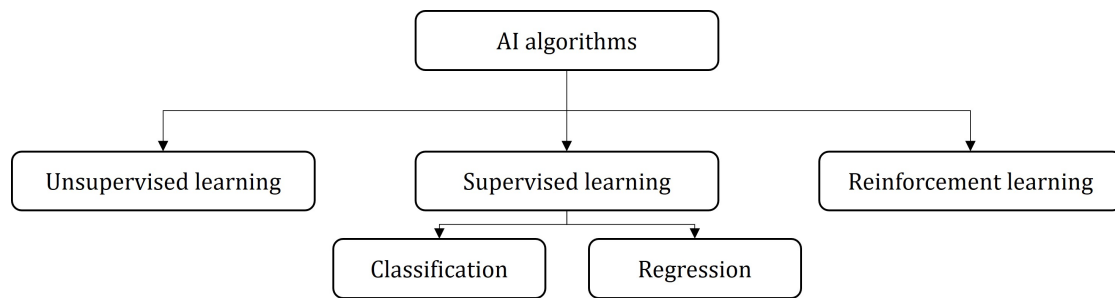

**Figure 2.12:** Different AI algorithms (Adopted from Ochella and Shafiee, 2019, p. 3427)

It is stated in the McKinsey Global Institute report by Bughin *et al.* (2017) that to ensure cooperation between AI-systems and operators, an AI-ready environment needs to be instituted. Managers have to be educated about AI-systems to allow them to build confidence in using these systems for supporting maintenance decision-making (Ochella and Shafiee, 2019).

## 2.3 Inner City Public Bus Services

In this section, the structure of inner city public bus organisations is discussed and an overview of inner city buses as well as bus maintenance is provided.

### 2.3.1 Organisational Structure

Inner city public bus services are organisations that provide daily transport services to residents in the cities where they are located. These organisations manage, maintain, and operate bus fleets to be able to provide transport services. The buses are normally stored at large depots where they are inspected and maintained. In most bus transit organisations, the buses are assigned to a scheduled route service on a daily basis (Haghani and Shafahi, 2001). The fleet of buses can be viewed as a pool from which the buses can be drawn for daily service or for maintenance (Haghani and Shafahi, 2001). The maintenance and routine inspections in this industry are performed on fixed time or kilometre intervals (Haghani and Shafahi,

2001).

Public transport systems vary around the world (Ibarra-Rojas *et al.*, 2015). In some cities, fare integration is provided city-wide while in others all services compete as independent alternatives (Ibarra-Rojas *et al.*, 2015). Due to the variation in the transport services provided across the globe, it is necessary to consider what inner city public bus services look like from different perspectives.

Golden Arrow Bus Service (GABS) is an illustration of what an inner city bus service looks like in the South African context. This organisation is situated in the City of Cape Town, where it is responsible for transporting people in and around the city. The GABS bus fleet consists of more than 1 000 buses that each travel 200 km per day and 6% of the bus fleet is kept as a reserve (Neethling, 2021). The transport service provided takes place along predetermined routes within the city (Neethling, 2021). These routes are predetermined by the City Council, who contract the transport services (Neethling, 2021). At GABS, a service strategy is followed where the buses are serviced according to the distances that they have travelled (Neethling, 2021). An important issue in this industry is the reliability of buses that degrade over time and as mechanical components are replaced their second life is mostly shorter, which also has a negative effect on reliability (Neethling, 2021). Breakdowns are a daily occurrence in this industry.

An example of an inner city public bus service from a European perspective is the city bus network in Munich, Germany. The bus network within Munich is operated by the Münchner Verkehrsgesellschaft (MVG), which also operates the subway and tram system within the city. The entire bus network is integrated to make it easier for travellers to commute around the city. The bus fleet of MVG consists of 400 buses that have the primary role to transport people to the subway and tram stations as well as to cover the outer districts of the city where there is no subway or tram access (getbybus, 2021). The MVG city bus network covers over 450 km and consists of more than 900 bus stops within the area of Munich (getbybus, 2021). The buses operated by MVG are low-floor buses that are equipped with ramps for easy wheelchair and stroller access (getbybus, 2021).



In the public transportation industry, the largest expenses are operating costs that mainly include the cost of the bus fleet, fuel, maintenance, and salaries (Bekesi *et al.*, 2009). Reducing the operational costs can result in an improvement in the Operational Expenditure (OPEX) of bus organisations.

### 2.3.2 Inner City Buses

As stated by Radman and Stelson (2016, p. 1699), the city bus can be classified as a “heavy-duty vehicle that operates on fixed routes, often subjected to low-speed and high-frequency stop-and-go driving conditions”. To obtain deeper insight into inner city buses, the operating conditions and possible power train configurations are investigated.

#### 2.3.2.1 Operating Conditions

Inner city buses face demanding daily operating conditions. Inter-urban bus service routes run through different infrastructure areas, yielding a wide array of speed ranges (Roca Rui *et al.*, 2012). Defining features of city bus driving cycles can be identified as the following (Kaczalski and Slaski, 2018):

- Low average speeds.
- High number of acceleration and deceleration phases.
- Short segments driving at constant speed.

The large amount of acceleration and deceleration is due to pulling away from stops and driving in congested stop-and-go traffic conditions (Kaczalski and Slaski, 2018). The driving cycle features of city buses indicate that, in normal operation, a large amount of stress and strain is exerted on the components of a city bus. This emphasises the important role maintenance plays in ensuring the city buses are able to handle the daily operating conditions.

### 2.3.2.2 Power Train

City buses have a very specific power train design to accommodate the requirement of having a low floor body (Kaczalski and Slaski, 2018). In the case of three-axle buses, the driveshaft and engine are mounted non-symmetrically, in contrast to the configuration of the standard vehicle power train. The non-symmetrical mounting may cause a decrease in the durability of bus drivetrain components (Kaczalski and Slaski, 2018). The driveshaft assembly of a low floor three-axle city bus powered by an internal combustion engine is demonstrated in Figure 2.13.

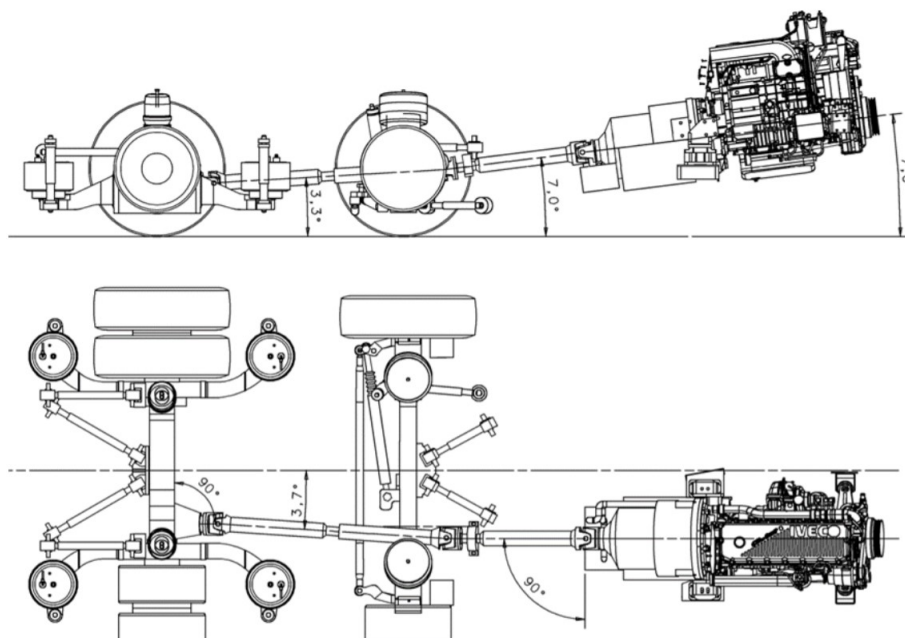

**Figure 2.13:** Driveshaft assembly of 15 m long low floor city bus (Adopted from Kaczalski and Slaski, 2018)

By taking into account the analysis of direct costs, battery electric buses are not currently cost-competitive with diesel-powered buses (Quartes *et al.*, 2020). However, the acquisition costs of electric buses are decreasing, mainly due to the decreasing battery prices, and will allow electric buses to become more cost-competitive in the near future (Quartes *et al.*, 2020). Using electric buses is not

yet desirable for entire fleets due to high acquisition costs as well as the disadvantage of the weight of the batteries (Radman and Stelson, 2016). Hybrid power train technology has become more widely used in the automotive industry recently and has already been adopted for service in some city bus fleets (Zheng and Cha, 2017). To take the latest developments of propulsion technology into account, the configuration of a hybrid power train system for a city bus is investigated, as illustrated in Figure 2.14.

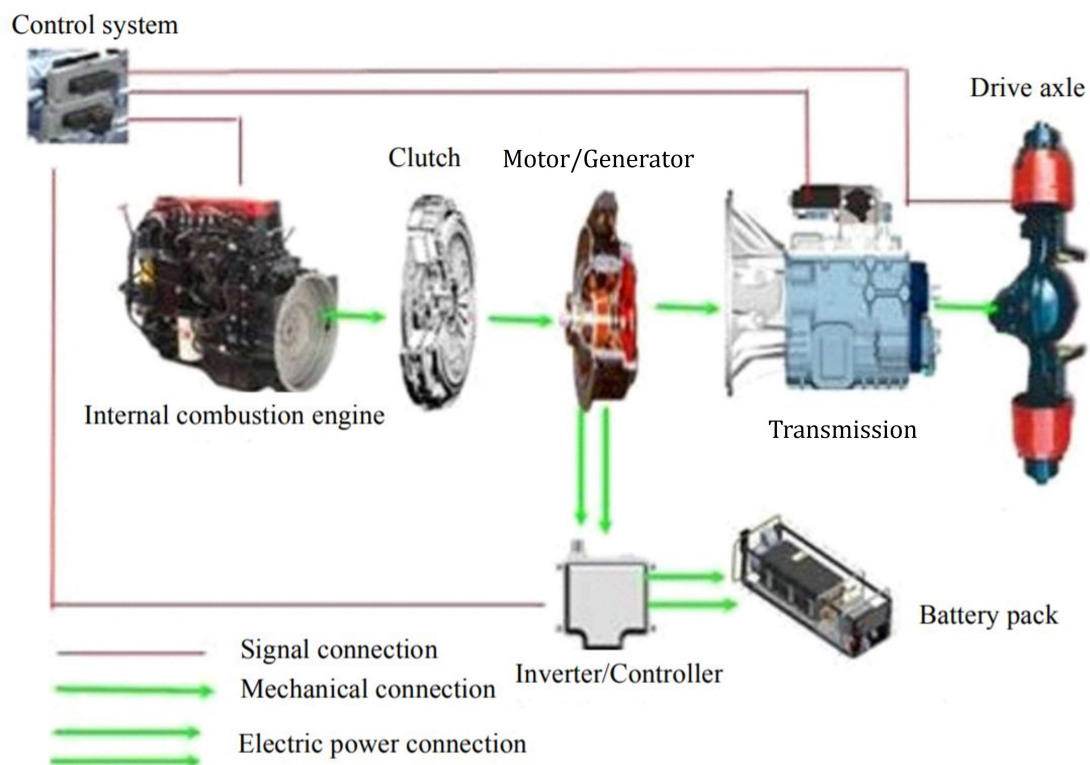

**Figure 2.14:** Structure of power train system of hybrid city bus (Adopted from Chen *et al.*, 2014, p. 4284)

The internal combustion engine and electric motor can drive the bus separately, and in hybrid mode drive the bus together as a power unit. A hybrid power train adds complexity to the technical structure of a city bus, but relatively simple mechanical components are added with an additional control system.

### 2.3.3 Bus Maintenance

Finding an efficient way to operate and maintain bus fleets has become an important issue in the transportation industry due to bus transportation being an important contributor to public transport (Martins *et al.*, 2021). According to Bivona and Montemaggiore (2010, p. 207), new bus breakdowns depend on the average failure rate of buses that, in turn, is influenced by the average age of the bus fleet and the frequency at which preventive maintenance is performed.

According to Martins *et al.* (2021), conducting bus maintenance in an efficient way requires the following:

- Define when and where maintenance should take place.
- Identification of buses from the fleet.
- Classify which maintenance tasks to perform.
- Assignment of resources and spare parts.

Through maintenance planning and scheduling, bus operating organisations aim to increase the availability of their fleet while taking their maintenance budget into account (Martins *et al.*, 2021). The number of buses available is viewed as a key resource for bus organisations as it has a direct influence on the level of service provided (Bivona and Montemaggiore, 2010). The maintenance system employed by bus transport services is directly related to the reliability, safety and vehicle life of buses (Haghani and Shafahi, 2001).

Haghani and Shafahi (2001, p. 456) divide bus maintenance into three categories:

- *Daily inspection*: Generally, bus transportation organisations do not have dedicated facilities for daily inspection, but place the responsibility on the drivers to perform daily checks before and after each shift. No scheduling is required for daily inspections.

- *Emergency maintenance*: When unexpected breakdowns occur while a bus is in service, emergency maintenance is required. This can drain maintenance resources and result in disruptions that can be costly for bus originations. During emergency maintenance, a mechanic is dispatched to determine the nature of the breakdown and fix it if possible. In most breakdown scenarios, the bus is towed back to the facility. There is no sure way of knowing beforehand if a bus will breakdown on a specific day.
- *Preventive maintenance*: This is the most important maintenance category and forms the bulk of the maintenance activities at the bus depot facilities. Buses are inspected and serviced according to predetermined kilometre or time intervals. Components that are identified to be near failure are replaced.

With the development of ICT, bus organisations implement information systems to assist their daily operation to ensure a modern business environment (Bekesi *et al.*, 2009). In bus maintenance, some activities are still completed by means of handwritten procedures which have to be manually transferred into the maintenance system (Borro *et al.*, 2021). Manual data processing is susceptible to errors and is often not executed at a satisfactory level of completeness (Borro *et al.*, 2021). Introducing Industry 4.0 technologies and digitalising bus maintenance can refine the process of data handling and reduce the number of unexpected errors.

## 2.4 Prognostics and Health Management (PHM)

Prognostics and Health Management (PHM) is overviewed in this section. It can be described as “a set of capabilities that enables one to detect anomalies, diagnose faults and predict remaining useful life, leading to the effective and efficient maintenance and operation of assets” (Li *et al.*, 2020).

PHM is a suitable approach to improve maintenance operations, reduce maintenance expenditures, and prolong the useful life of equipment through evidence-based maintenance practices (Bailey *et al.*, 2015). PHM is a key contributing process for CBM or predictive maintenance (Medjaher *et al.*, 2013). Diagnostic

and prognostic information is utilised in PHM systems. Vehicle diagnostics and prognostics approaches are discussed in this section to understand how a PHM strategy can be realised.

### 2.4.1 Vehicle Diagnostics

Diagnostics focuses on the detection and identification of faults (Ayab *et al.*, 2018). This section discusses the important aspects involving the diagnostics of vehicles.

#### 2.4.1.1 On-Board Diagnostics (OBD)

On-Board Diagnostics (OBD) is defined as a “computer-based system developed by automobile manufacturers for diagnosing vehicles” (Moniaga *et al.*, 2018). The latest standard is called OBD-II (Hasan *et al.*, 2011; Amarasinghe *et al.*, 2015). The OBD-II was developed by the Society of Automotive Engineers (SAE) and the Environmental Protection Agency (EPA) that defined the specifications for all manufactured vehicles to allow for regulating emissions (Malekian *et al.*, 2017). The standard requires all vehicles to be equipped with a 16-pin OBD-II port (Malekian *et al.*, 2017). External diagnostic and maintenance systems can be interfaced with a vehicle through the OBD-II port (Ammar *et al.*, 2020; Massaro *et al.*, 2020).

OBD scanner tools are expensive devices and are usually owned by workshops (Hasan *et al.*, 2011). Recently, more affordable OBD-II scanners have been introduced to use vehicle networks for diagnosing and monitoring the condition of a vehicle (Moniaga *et al.*, 2018). The use of OBD-II for real-time monitoring has become more popular in the field of fleet management (Malekian *et al.*, 2017). The OBD was only designed to scan vehicles diagnostics, but to read, process, and present the data, a microcontroller is needed (Moniaga *et al.*, 2018). The ELM327 is an example of a microcontroller that is used to automatically interpret OBD-II signals and which can enable wireless sensor data reading through a Bluetooth function (Malekian *et al.*, 2017). The OBD-II port provides direct access to a

vehicle's CAN bus (Ammar *et al.*, 2020).

#### 2.4.1.2 Controller Area Network (CAN)

The CAN is a communication medium that provides simple and efficient communication between networks within vehicles which was standardised by the International Organisation for Standardisation (ISO) in the 1990s (Davis *et al.*, 2007). It is the most commonly used convention in OBD-II (Ammar *et al.*, 2020). In automotive applications, a double line CAN bus architecture is normally used, consisting of transmission and receiving lines that connect the different bus line nodes (Malekian *et al.*, 2017).

The CAN network consists of several ECUs connected by a two-wire bus that supports two CAN standards namely: low-speed CAN (up to 125 Kbps) and high-speed CAN (up to 1 Mbps) (Ammar *et al.*, 2020). ECUs consist of a CAN transceiver and CAN controller. CAN message transfer is controlled by four different types of frames: data frames, remote frames, error frames, and overload frames (Davis *et al.*, 2007). The messages sent on CAN are used to communicate signals between different ECUs. Typically, in automotive applications, CAN is used to provide high-speed networks connecting the vehicle chassis and power train ECUs (Davis *et al.*, 2007).

#### 2.4.1.3 J1939

SAE J1939 is a set of standards based on the architecture of CAN (Prasad *et al.*, 2019). The SAE J1939 is mostly used for heavy commercial vehicles and is the recommended protocol for communication and diagnostic interaction among the components of heavy-duty vehicles (Prasad *et al.*, 2019). The messages exchanged between the ECUs can consist of data such as the vehicle's road speed, torque control, and oil temperature (Voss, 2008).

The SAE has set out a J1939 document defining sensor types, names, IDs, and other relevant information. The Suspect Parameter Number (SPN) is defined by the SAE J1939 standard and is a number that contains individual parameters as a standardised message. The Parameter Group Number (PGN) is also a number defined by the SAE J1939 standard and groups the different SPNs into relevant groups. An example is the PGN 65262, that is a parameter group named *Engine Temperature 1* (SAEJ1939, 2017). The group includes the following parameters (SAEJ1939, 2017): *Engine Coolant Temperature*, *Engine Fuel Temperature 1*, *Engine Oil Temperature 1*, *Engine Turbocharger Oil Temperature*, *Engine Intercooler Temperature*, and *Engine Intercooler Thermostat Opening*.

## 2.4.2 Prognostic Approaches

According to Killeen (2020, p. 18), prognostics is the process of predicting the health status of equipment that is being monitored. Bailey *et al.* (2015, p. 2), define two available approaches to evaluate the degradation or the degree of deviation from the expected performance of a system to assess reliability and to make remaining useful life predictions. The two approaches are data-driven and model-based, as illustrated in Figure 2.15. Combining the two approaches creates a fusion approach.

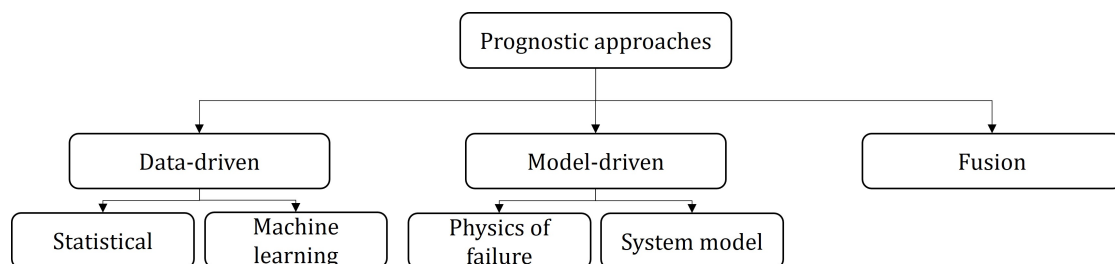

**Figure 2.15:** Classification of PHM approaches (Adopted from Bailey *et al.*, 2015, p. 2)

The model-driven approach can be classified into physics of failure and system model approaches (Bailey *et al.*, 2015). Mathematical and degradation models



are used in model-based prognostics to estimate the current and future health status of equipment to enable remaining useful life estimations (Medjaher *et al.*, 2013). A model-driven approach is able to give more accurate remaining useful life predictions, but in terms of implementation, a data-driven approach is less challenging (Mohammadpour *et al.*, 2011). The data-driven prognostics approach may be preferable due to it being able to make the trade-off between precision, complexity, and implementation cost (Medjaher *et al.*, 2013).

Modern sensing technologies have resulted in large amounts of available data enabling data-driven methods for the health assessment of assets (Palazuelos and Droguett, 2021). Data-driven prognostics use data from sensors monitoring systems to build a model of trends and conditions (Medjaher *et al.*, 2013). Figure 2.15 indicates that the data-driven approach can be divided into statistical and machine learning approaches. Machine learning approaches use gathered data alongside sensor data to make predictions. The machine learning approach can include the use of neural networks, support vector machine (SVM), the Wiener process, Markov, and hidden Markov models (Li *et al.*, 2018).

Statistical techniques involve fitting a model to the acquired data and then applying a statistical inference test to determine if an instance in question can be associated with the model or not (Chandola *et al.*, 2009). The primary advantage of a statistical approach is that if the statistical characteristic assumptions are true, the outcome of the interference test for new estimations is statistically reasonable (Bailey *et al.*, 2015). The most commonly used statistical model is the Weibull distribution, that can be applied as a simple lifetime distribution approach (Li *et al.*, 2018). The Weibull models are popular in reliability and survival analysis, where they are used to describe various types of component failures and occurrences (Lai *et al.*, 2006).

One of the most widely used non-parametric statistical approaches is the use of histograms for analysis (Bailey *et al.*, 2015). It is one of the simpler modelling approaches (Byttner *et al.*, 2013). Histogram anomaly detection consists of two steps: the first step is to build histograms based on the different values that fea-

ture in the training data, and the second step is to check if the test instance falls within the bins of the histogram (Chandola *et al.*, 2009). If the instance that is being tested falls within the bins of the histogram, it is normal, otherwise, it can be identified as an anomaly.

## 2.5 Related Research

In this section, research related to this study is summarised and discussed. It is necessary to gain insight into what has been done in industry and where opportunities possibly exist for complementary research and investigation. Each of the related studies is briefly introduced, their solution approaches are discussed as their systems, and an overview of each study's results is provided.

### 2.5.1 Cloud-Based Driver Monitoring and Vehicle Diagnostic with OBD-II Telematics

Amarasinghe *et al.* (2015) proposed a cloud-based data acquisition and analytics system for real-time driver behaviour monitoring and vehicle diagnostic system. The data is read from an OBD-II port and processed. The key information is presented to the user through an Android application and a web server.

#### 2.5.1.1 System

The system consists of an OBD port connected to a Bluetooth adaptor, a mobile application, and a cloud-based server. The Android application gathers sensor data from the OBD-II using an ELM-327 Bluetooth adaptor and performs predictive analytics as well as providing data storage and visualisation. The Android application forwards sensor data to the cloud server using Hypertext Transfer Protocol (HTTP) messages over a 3G or 4G network connection.

A Complex Event Processor (CEP) is used in the smartphone application and the cloud-based back-end to detect and notify unsafe behaviour and abnormal events in real time. An example is that the CEP engine in the application can alert the driver about rising engine coolant temperature and fast-declining fuel levels. The CEP on the cloud server detects reckless driving in real time using the sensor data provided from the OBD-II port. The historical data that is stored on the cloud-based server is also used to detect abnormal driver behaviour and to predict sensor failures. The more complex data processing is performed on the cloud using  $WSO_2$  BAM and stored in a SQL database.

The driver monitoring includes identifying reckless driving and the detection of driver anomalies. Reckless driver monitoring is mostly used for insurance companies, and the detection of driver anomalies is more concerned with fuel efficiency and safe driving. In the investigation process, the study found that the acceleration pattern and not the speed pattern is unique to each driver. The Markov model was selected to determine the difference between current and past driving patterns of the driver and vehicle combination. Anomalies are detected in real time by the calculation of the probabilities of the Markov Chain resulting from recent accelerations.

The study proposes a solution to detect impending sensor failures so that they can be identified earlier. The sensors that are focused on are the  $O_2$  and Mass Air Flow (MAF) sensors. These two sensors were identified as the two most crucial in determining engine performance and emissions. In the solution to determine if the  $O_2$  sensor is failing, the maximum and minimum voltages are read by the application for 15 minutes at the start of each trip and transmitted to BAM. The back-end server performs two regression analyses on the maximum and minimum values to predict the potential date of failure. The failure prediction of the MAF sensor is done by analysing the linear relationship between the MAF sensor reading and the engine rpm. Regression is used to predict the potential date of sensor failure.

### 2.5.1.2 Results

In the study, insufficient data was available to execute full-size experiments to validate the functionality of the proposed system. Instead, synthetic data was generated to run the experiments. During the study, there was also no access to fault data, which meant that actual data could not be used to test the fault diagnostic algorithms.

An Android application that supports the predictive maintenance system was implemented as well as a web application that reports results from the cloud-based server. The study showed that it was possible to predict the remaining useful life of the  $O_2$  and MAF sensor using synthetic data.

A drawback of the system is the fact that the system relies on the driver or passenger to have access to a smartphone capable of running the Android application. This system is less autonomous than an on-board system that is physically installed onto the vehicle that is being monitored.

## 2.5.2 A Field Test With Self-organized Modelling for Knowledge Discovery in a Fleet of City Buses

Byttner *et al.* (2013) propose an approach towards data-driven decision-making in maintenance. The study aims to show that it is possible to extract useful diagnostic knowledge from a fleet of city buses using a self-organised algorithm. In the process, the study attempts to identify the most interesting signals and utilise maintenance records to make informed decisions. The definition given in the study for an interesting signal is a signal that is not random.

### 2.5.2.1 System

In the approach, the study split the data mining process of discovering how the buses work into unsupervised modelling and a guided search.

The first part of the approach consists of unsupervised modelling. Histograms are identified as a computationally cheap method to model signals. The Bhattacharyya distance and “symmetry index” are suggested as good metrics to compare histograms. On-board analytics are performed on each bus before the data is sent to a central server where the final processing takes place to perform fleet wide analytics. The behaviour of the fleet is defined as normal behaviour, and if a vehicle deviates from the rest of the fleet, it is identified as portraying abnormal behaviour.

The second part is a guided search that involves finding the connection between the results from the first part and external information sources (database of vehicle service records). The aim of the guided search is to identify patterns that are related to the breakdown and degradation of components. The study identifies three strategies for this part: database relation mining, cloud-based diagnosis software, and simulation-based mining.

During the field test, signals were collected with hardware installed on the CAN network from a fleet of 18 city buses. The data was collected while the buses were in normal daily operation. The sensor data is processed using histograms and linear models. To estimate the repair dates, the study uses vehicle service records of the entire fleet.

Histograms for each signal are collected hourly from all the vehicles. The histograms are ranked according to their entropy to measure how interesting a signal is. Each vehicle is assigned a health status weekly by comparing the distances of groups of histograms based on the empirical distribution. When a vehicle’s histogram has 5% outliers, it is flagged as a *warning*, with 50% an *orange alert* is issued, and 75% a *red alert*. The distance between histograms are computed using the Bhattacharyya distance.

In the second approach, linear models are used. Data is gathered for a 30-hour period of 12 signals to analyse the pairwise relations of the signals. The linear

model is represented by Equation 2.5.1.

$$x_1 = b_1x_2 + b_2 \quad (2.5.1)$$

The parameters  $x_1$  and  $x_2$  are the signal pairs,  $b_1$  is the slope, and  $b_2$  is the intercept of the linear model. Signal pairs with smaller Mean Squared Error (MSE) have stronger relations. Faults are identified when the  $b_1$  and  $b_2$  values show a deviation from the rest of the fleet. The possible faults are diagnosed by looking up the dates the deviations occurred in the vehicle service record database.

### 2.5.2.2 Results

The study was able to detect faults, assign health statuses to vehicles as well as diagnose faults when deviations occur from using the service record database with vehicle repair dates.

The study does not provide an architecture outline of the system and hardware used to collect the CAN network data. There is also no clear definition of how the threshold is defined to determine deviations.

### 2.5.3 IoT-based Predictive Maintenance for Fleet Management

Killeen *et al.* (2019) present an IoT architecture for a predictive maintenance fleet management system and fleet-wide data analytics that is supported by the proposed architecture. A semi-supervised machine learning algorithm is also proposed that attempts to improve the sensor selection performed in Consensus Self-Organised Models (COSMO) that the study calls Improved Consensus Self-Organised Models (ICOSMO). The COSMO approach is an example of a predictive mainte-

nance system for a fleet of public transport buses that attempts to diagnose faulty buses that diverge from the rest of the fleet (Rognvaldsson *et al.*, 2017). The predictive maintenance fleet management system developed in this study is aimed at the buses of a public transport organisation based in Gatineau, Canada.

### 2.5.3.1 System

The proposed predictive maintenance IoT architecture, shown in Figure 2.16, is designed to support fleet management and specifically focuses on public transport buses.

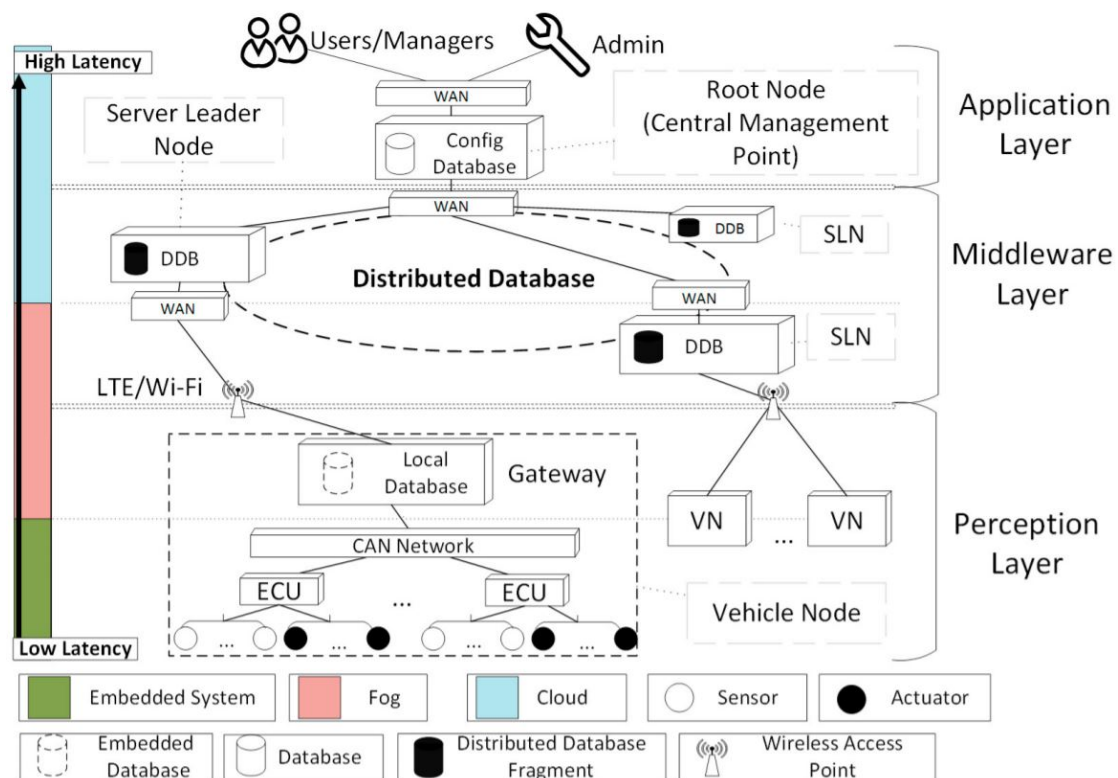

**Figure 2.16:** Predictive maintenance fleet management system architecture-overview diagram (Adopted from Killeen *et al.*, 2019, p. 609)

The architecture is divided into three layers: the perception layer, the middleware layer, and the application layer. The architecture layers are derived from the outlined layers of IoT, discussed in Section 2.2.2. The perception layer performs sensing, lightweight data storage, machine learning, and provides an interface to low-level nodes. The fog and embedded systems are incorporated in the perception layer. In comparison to the perception layer, the middleware layer abstracts the fog and the cloud and conducts more heavy-duty storage, networking, and machine learning. The interface to the perception layer is provided through the middleware layer. The application layer provides the interface to the IoT system.

The system comprises of an integrated IoT network that consists of three primary nodes namely: the Vehicle Node (VN), the Server Leader Node (SLN), and the Root Node (RN). The VN represents the vehicle, which in this case is the bus, and does basic data acquisition and analytics. The VN is connected to the fleet system through a wireless internet connection. The SLN is responsible for the more difficult fleet-wide analytics. The RN, located in the application layer, is the central point of the system which controls the entire fleet and provides the application interface. It serves as the primary access point for the fleet system, providing an interface for IoT applications, connecting fleet nodes to the system, and allowing for fleet-wide management.

The objective of the predictive maintenance system is to make novel discoveries and provide this knowledge to fleet managers so they can make better maintenance decisions. The study reasons that to equip multiple buses with gateways enables fleet-wide analytics and creates the possibility of discovering some novelties. During the design process of the study, numerous discussions were arranged with the public bus transportation company to determine the requirements of the prototype.

### 2.5.3.2 Results

The study implemented the proposed architecture as a minimally viable prototype at a public bus transportation company and only equipped a single bus with a



gateway to gather data during the investigation. The implemented prototype allowed for the acquisition of 1 GB of uncompressed J1939 data through daily data dumps. The data is stored on the SLN at the bus organisation garage. Through analysing the J1939 data, various data types were obtained, namely: sensor data, status of equipment, network routing information, and Diagnostic Trouble Code (DTC)s. The study concludes with the intention of completing the implementation of the proposed architecture and to run further experiments.

#### 2.5.4 Predictive Maintenance of Bus Fleet by Intelligent Smart Electronic Board Implementing Artificial Intelligence

Massaro *et al.* (2020) investigated predictive maintenance of a bus fleet by utilising an intelligent smart electronic board that implements AI. The study focused on designing, developing, and implementing a smart and compact Electronic Control Unit (ECU) for monitoring a bus fleet. The engineered system is developed and designed for bus fleet data acquisition for the purpose of managing maintenance through the use of predictive analytics. This research project also incorporated a GPS system and surveillance system to monitor each individual bus.

##### 2.5.4.1 System

The electronic architecture is illustrated in Figure 2.17 that relates to the data acquisition on-board system. The ECU is connected to the OBD-II port that transfers data to the raspberry Pi board. Using an internet key, the data is transmitted from the raspberry Pi through the internet to the cloud. The data is processed by a server using an AI algorithm.

The ECU system is used to extract all the necessary vehicle data according to the OBD-II and SAE J1939 standards. An integrated IoT system is interconnected in the cloud by AI that implements Multilayer Perceptron Artificial Neural

Network (MLP-ANN) and predicts the maintenance of each vehicle by classifying driver behaviour.

In the cloud, the vehicle's data is transferred to a data mining engine that performs driver Key Performance Indicator (KPI) by defining a score. This is achieved by k-means clustering analysis and the prediction of engine stress through MLP-ANN. The study tested the data mining algorithms using stable datasets provided with a low MSE that confirm the accuracy of the model.

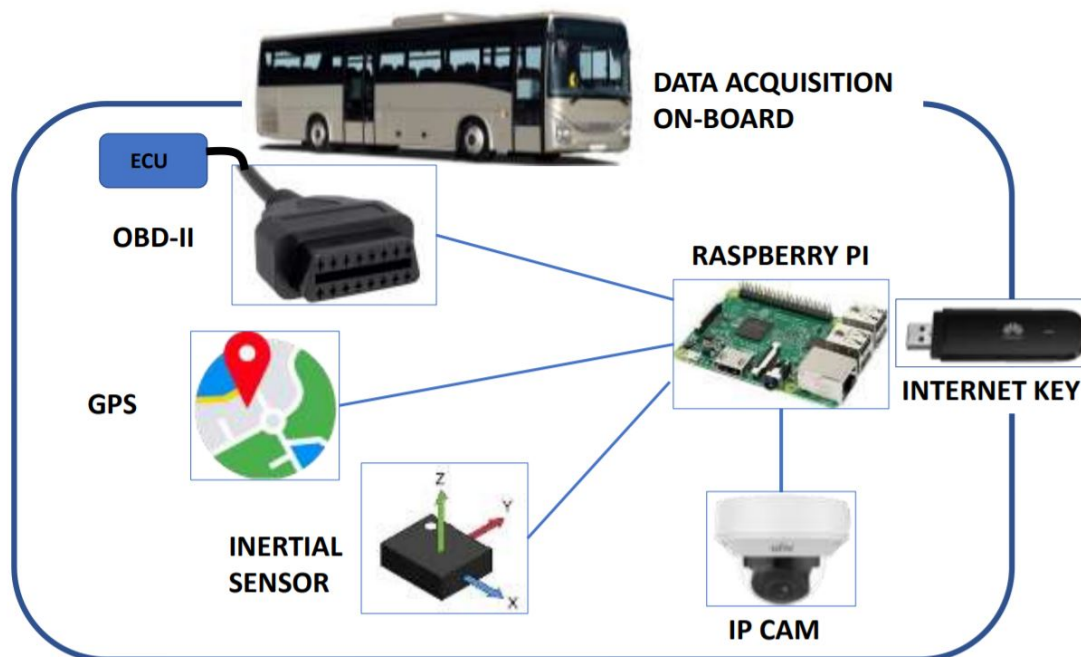

**Figure 2.17:** Architecture of the data acquisition on-board system (Adopted from Masaro *et al.*, 2020, p. 182)

The planned scheduling of bus maintenance can be anticipated for each vehicle by the prediction of high engine wear using the MLP-ANN. When higher engine wear, which is a function of driver behaviour, is predicted, the standard predictive maintenance plan can be adjusted to schedule the specific bus for an earlier service.

The driver's style and behaviour are categorised into three clusters by analysing parameters such as the GPS speed, engine RPM, engine load, and throttle position. The three clusters are Key Performance Indicators (KPIs) concerning the driver velocity, engine stress, and driver caution. Each of the clusters can be given a score of low, high, or average. The predicted results and KPI are normalised and expressed as a percentage. The study defines the score threshold in percentages as low: 0% to 40%, average: 41% to 60%, and high: 61% to 100%.

The correlation matrix results of the study show that a high correlation exists between throttle position and engine load, as well as between throttle position and engine RPM. There is a moderate correlation between engine RPM and GPS speed that, according to the study, indicates correct gear selection by the drivers.

Data is sampled every second, and all the data is combined for a basic daily analysis. Dashboards are created to indicate the wear levels of an individual bus as well as to give an indication of the predictive scheduling of maintenance. All the collected data can be processed for monthly and yearly estimations to provide criteria for predictive maintenance.

The efficiency of the bus fleet is estimated by the engine stress prediction and driver KPI. The resulting efficiency parameters are kept on a database and visualised remotely using dashboards. The vehicle health status, KPI, fuel consumption efficiency, and driver efficiency are all monitored online to enable informed maintenance plan decisions.

#### **2.5.4.2 Results**

From the results analysis, the study defined methodologies of KPIs that correlate driver behaviour with the engine stress from which the bus maintenance plan criteria are defined. The study shows that it is possible to combine IoT bus status monitoring devices with data mining algorithms to estimate engine status predictions and driver behaviour.

Information regarding the state of the bus fleet is stored in a database and remotely visualised. The possibility exists of incorporating a feedback system that updates the driver on his KPI that allows for immediate adjustments to driver style and efficiency that could ultimately improve the reliability of a bus.

### 2.5.5 Related Research Summary

The related studies discussed in this section show there is an opportunity to design, implement and validate a smart maintenance system for inner city public bus services. From the related studies, it can be seen that research and testing have been done on optimising and digitalising maintenance in this industry, but no comprehensible smart maintenance system exists as yet.

The requirements and outline of a smart maintenance system discussed in Section 2.1.3 can be integrated with the predictive maintenance fleet management system from the related study in Section 2.5.3 to create a smart maintenance system for inner city public bus services. The architecture of an on-board data acquisition system in Section 2.5.4 can be used as a guideline for the physical hardware setup of the smart maintenance system.

## 2.6 Chapter Summary

The purpose of this chapter is to review literature relating to the problem statement and objectives. Maintenance and maintenance strategies are defined, relevant Industry 4.0 technologies that support smart maintenance are discussed, an overview of inner city public bus services is provided, and prognostics and health management are investigated. Research related to this study is also examined and included in the literature review.

# Chapter 3

## Research Design and Methodology

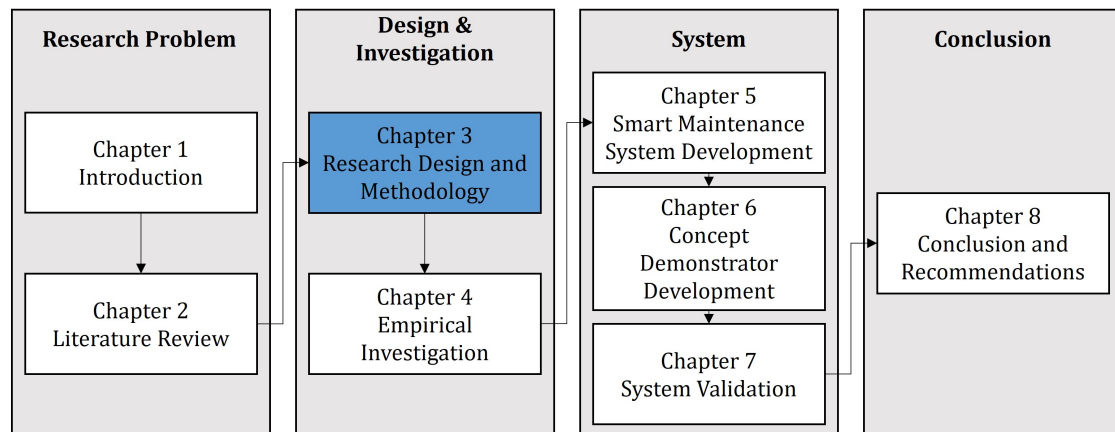

The purpose of this chapter is to discuss the research strategy and methodology. The chapter starts with an outline of the research approach and a summary of the study is provided. The chapter concludes with the research techniques utilised in the thesis.

### 3.1 Research Approach

The research approach is the planned strategy for conducting the research. According to Creswell and Creswell (2018, p. 41), there are three approaches to

research: qualitative, quantitative, and mixed methods. A research approach consists of three elements: philosophical worldviews, research design and research methods (Creswell and Creswell, 2018). The relationship between the elements is illustrated by the framework in Figure 3.1. Additional considerations for the selection of the approach are the nature of the research problem, the researcher's personal experience and the audience of the study (Creswell and Creswell, 2018). The research approach is set out in the following sections based on the research framework shown in Figure 3.1.

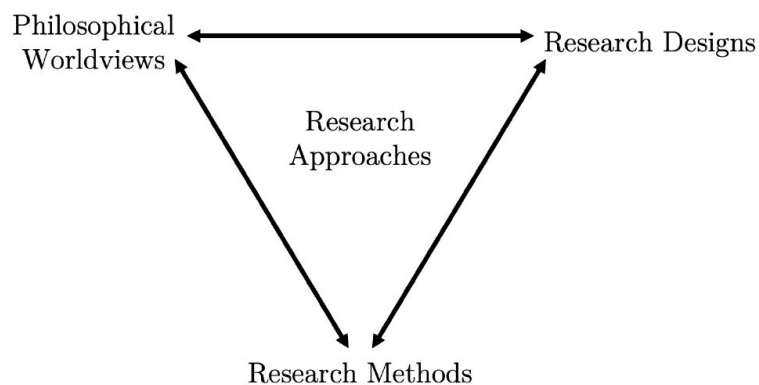

**Figure 3.1:** Research framework (Adopted from Creswell and Creswell, 2018, p. 43)

### 3.1.1 Philosophical Worldview

The philosophical worldview is used to describe how knowledge is developed. A research philosophy is formed based on numerous assumptions to support the research design and methods (Saunders *et al.*, 2015). The research in this study follows a pragmatic worldview. This worldview focuses on the research problem and employs all available approaches to understand the problem (Cherryholmes, 1992). Pragmatism is not committed to a single system of philosophy and reality. The pragmatic worldview relies both on quantitative and qualitative assumptions when research is conducted. This applies to a mixed method strategy of research.

### 3.1.2 Research Design

According to Creswell (2009), research designs are research plans and procedures that range from broad assumptions to detailed methods of data collection and analysis. Research designs represent the different research strategies: namely, qualitative, quantitative, and mixed method approaches (Creswell and Creswell, 2018).

Quantitative research is an investigation into a specific problem that is based on testing a theory, measured with numbers, and analysed using statistical methods (Dobbin and Gatowski, 1999). The objective of quantitative methods is to determine whether a theory's predictive generalisations are correct. A study based on a qualitative research process, on the other hand, seeks to understand a social or human problem from multiple perspectives. Qualitative research is carried out in a natural setting and entails the process of constructing a complex and holistic understanding of the situation of interest (Dobbin and Gatowski, 1999).

Mixed methods research provides a practical approach to addressing research problems and questions, as well as the potential for increased validity because the problems and questions are investigated in various ways (Graff, 2017). The research design of this thesis is a mixed method consisting of qualitative and quantitative data collection and analysis. The mixed method design is utilised for this thesis since the research questions are of an exploratory and descriptive nature. The exploratory research questions require qualitative research to gain a deeper understanding of the investigated factors. In contrast, the descriptive research questions require quantitative research.

Specifically, the type of mixed method approach that is followed is the exploratory sequential design. This type of mixed method approach is characterised by an initial qualitative data collection and analysis phase, which is followed by a quantitative data collection and analysis phase that builds on the results of the first qualitative phase (Creswell, 2009). In the final phase of the exploratory sequential mixed method design, the qualitative and quantitative phases are integrated.

### 3.1.3 Research Methodology

The methodology of the research approach of this thesis is discussed and set out in this section. The forms of data collection, analysis, and interpretation proposed by researchers for their studies are referred to as research methods (Creswell, 2009).

Against the background of the research design, five research phases are used to answer the research questions. The context and structure of the research phases are aimed toward the investigation and development of a smart maintenance system to ultimately answer the Primary Research Question (PRQ).

In the methodology for the development of a conceptual system, Jabareen (2009, p. 53), suggests utilising multidisciplinary literature types, for instance, text identified by literature reviews, and empirical data obtained through interviews. The fundamentals of the development of a smart maintenance system are understood in the first phase of the research through a detailed literature review. The first few phases in the research methodology rely on secondary data from various sources. These sources include numerous literature categories and knowledge from the industry.

When attempting to define a new concept that has not been extensively studied in the previous literature, the use of some inductive, qualitative techniques, such as interviews and case studies is required, to adequately sketch out the domain of the concept (Podsakoff *et al.*, 2016). Structured interviews are conducted online to further investigate the research questions of this study and gather empirical data. After the essential aspects of smart maintenance are understood, the development of a generic system can commence. The findings of the literature review are combined with the results and feedback from online interviews to configure the system.

The system is developed before taking the specific requirements of an industry partner into account. The testing and partial implementation of the system with



an industry partner as a case study provides validation that the system is effective in providing the solution to the problem. Case studies are a qualitative strategy where researchers collect information using a variety of data collection techniques over a sustained time period (Creswell, 2009). After the validation phase and interaction with an industry partner, the smart maintenance system is refined where necessary to ensure that the system is as complete and effective as possible.

The research design of this thesis can be divided into different phases that follow separate approaches, processes, and methods. The breakdown of the research design and methodology is presented in Table 3.1.

**Table 3.1:** Breakdown of research design and methodology

Phase	Approach	Process	Method	Chapter
1	Qualitative	Data collection	Literature review	2
2	Qualitative	Data collection	Structured interviews	4
3	Quantitative	Data collection	Descriptive statistics	4
4	Qualitative	Data analyses	System development	5 & 6
5	Qualitative	Validation	Case study	7

In this chapter the research design, methodologies and methods are discussed for this thesis. The following chapters cover the research phases identified in Table 3.1.

## 3.2 Chapter Summary

The objective of this chapter is to define the research design and methodology. The research approach is outlined and an overview of the study is given. To conclude the chapter, the research techniques used in this thesis are laid out.

# Chapter 4

## Empirical Investigation

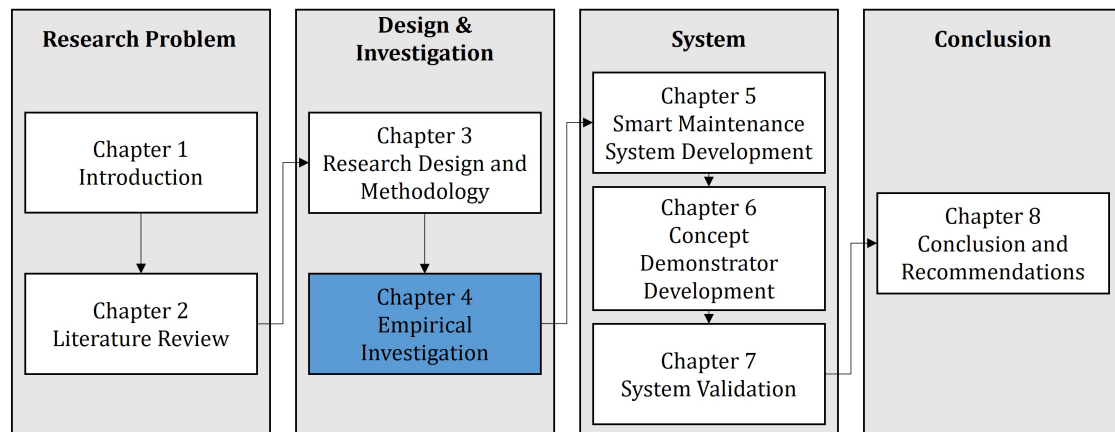

The objective of this chapter is to conduct an empirical investigation as a supplementary method of data collection for this research. The empirical investigation is used to further investigate the factors influencing the degradation of the reliability of inner city buses as stated in Research Objective (RO) (c); identify what key components are responsible for most of the downtime specified in RO (d); and how the unit life of these components can be improved as set out in RO (e). In the process, this investigation assists in answering Secondary Research Question (SRQ)2.

## 4.1 Empirical Investigation Conditions

The empirical investigation is conducted by means of interviews. The objective of the interviews is to gather new insight and information through conversations with one interviewee at a time. Interviews are a method of data collection in which quantitative or qualitative questions can be asked (Doody and Noonan, 2013). Direct interviews between a researcher and an interviewee allow a small number of people to be interviewed in depth and provide insight into a variety of experiences (Stofer, 2019).

The utilisation of interviews for further data collection is motivated by the insufficiency of information available on what factors and key components directly affect the reliability of inner city buses. The interviews are also used to gain additional insight with respect to the maturity level of Industry 4.0 technologies in maintenance at inner city bus services. We can thus get an idea of the degree of digitalisation of their maintenance practices from an internal viewpoint. The aspects and requirements of smart maintenance in this industry are explored through the interviews. Industry knowledge and expertise are beneficial to the research and add novelty.

Interviewees are representatives of inner city bus services. The interviewees are identified by preferably being in a maintenance manager role or similar organisational position at an inner city bus service. The strategy for identifying representatives to interview was to contact organisations of interest through invitational emails, which explain the motivation of the research and ask for the opportunity to interview a suitable employee. Four interviewees took part in the interviews and were purposively chosen to represent organisations equally from South Africa and Europe. The geographical distribution of the interviewees is intentional to support the development of a generic system. This also allows for an understanding of inner city bus services in the context of a developing and developed region. For the European representation, German organisations are selected due to the research in this thesis is conducted in partnership with a German University.

An introductory summary of the research project, the interview schedule, consent form, and institutional paperwork, were sent to each interviewee beforehand. The interviews were conducted online using the Microsoft Teams application. The interviews were recorded with the consent of the interviewees to ensure accurate interpretation of the results.

The interview schedule was created in accordance with Stellenbosch University's ethical requirements and approval was obtained from the university's research ethics committee. The notice of approval from the research and ethics committee, the consent form, the institutional permission paperwork, and the interview schedule are attached in Appendix A.

The interview style is of a structured nature to ensure standardisation of the interviews. Bryman and Bell (2011, p. 202), state that a structured interview, occasionally called a standardised interview, involves the administration of an interview schedule by an interviewer. The goal is for all interviewees to be subjected to the same set of questions, which is determined in advance, using exactly the same order and wording each time (Stofer, 2019). The structured interviewing style ensures that interviewee responses can be combined and compared, which can only be done confidently if those responses are in reply to identical cues. Questions are typically very specific, and are often called closed-ended or fixed choice questions (Bryman and Bell, 2011). Interviewees are given a fixed range of answers (Bryman and Bell, 2011). When asking close-ended questions, the interviewer presents two or more possible answers to interviewees and asks them to choose which one or ones apply.

The main advantage of close-ended questions, in comparison to open-ended questions, is that they reduce a possible source of error and make the process of quantitative data analysis easier (Bryman and Bell, 2011). The responses to an open-ended question must be sorted before the data can be quantitatively analysed.

## 4.2 Structure of Interviews

The interview questions are derived from the literature review conducted in Chapter 2. Close-ended and open-ended questions are used in the interviews. Most of the questions are close-ended for easier data analysis and comparison. A few open-ended questions are included to allow for a topic to be discussed in more detail if the interviewee possibly has more knowledge on the subject. Due to the majority of the questions being close-ended, the interview style remains structured.

In structured interviews, the interviewees are each asked the same questions in the same order (Doody and Noonan, 2013). This is accomplished with the help of an interview schedule, which contains the set protocol of questions that is to be adhered to throughout the interviews (Ryan *et al.*, 2009). The structure of the interview is divided into four parts, which are explained in the following sections. Appendix A contains a detailed overview of the interview schedule.

### 4.2.1 Part 1: Acquire Context

The first part of the interview covers the introduction and it sets the context. The first question at the start of the interview asks about the interviewee's area of expertise as a maintenance practitioner at their organisation. There are also some basic sub-questions about the maintenance strategy and record-keeping at the interviewee's organisation. The different maintenance strategies have been identified in Section 2.1.2 and a definition is provided in the interview schedule of each maintenance strategy to eliminate misinterpretation. The initial set of questions serves as an introduction to the interview while also providing the interviewer with a foundation for the interviewee's responses to the questions that follow.

### 4.2.2 Part 2: Industry 4.0 Technology Maturity

The objective of the questions in the second part is to empirically evaluate the maturity level of Industry 4.0 technologies in maintenance at inner city bus services.

The feedback from these questions can indicate to what extent the maintenance process at inner city bus services is digitalised with Industry 4.0 technologies. This can illustrate the degree of digitalisation required to get them closer to smart maintenance. In Section 2.2, the Industry 4.0 technologies that support smart maintenance have been identified as: Big Data and analytics, IoT, cloud computing, CPS, and AI. The definitions for the different Industry 4.0 technologies are provided to ensure the interviewer and the interviewee have the same understanding of the concepts to avoid any misunderstanding. The interviewees are asked if they implement any of the set principal requirements for each Industry 4.0 technology. Three principal requirements are derived for each technology from literature and defined in Question 2 of the Interview Schedule in Appendix A.4. The maturity level is determined according to the number of principal requirements met for each technology.

### **4.2.3 Part 3: Factors Influencing Bus Reliability**

The third part of the interview investigates the factors and key components that directly influence bus reliability. First, the interviewee is asked to rank, according to relevance, the factors influencing the reliability of a bus. The factors are derived from the literature review. The use of an open-ended question is employed to determine which key components are responsible for most of the downtime of inner city buses in the interviewee's organisation. The key components could not be identified from the literature review, thus industry knowledge is required. The interviewee is also questioned about what historical service data is available on the key components identified, with set answers to choose from.

### **4.2.4 Part 4: Smart Maintenance**

In the last part, the interviewee is asked if they utilise diagnostic or prognostic information in their maintenance practices with regard to a PHM approach in their maintenance. Subsequently, the interviewee is also asked what the preferred

interval is to receive health status updates and detection.

Two further questions are included, the first of which asks the interviewee to rank the most desirable way smart maintenance can improve their maintenance, and the second asks them to rank the most important aspects to consider when implementing smart maintenance. The selection of set choices is derived from the literature review.

The last question asks the interviewee to score the importance of the different requirements of a future, smart, maintenance planning system by giving each requirement a score of one to five, with one being the least important and five being the most important. The requirements are extracted from the literature review in Section 2.1.3.

## 4.3 Empirical Investigation Results

The following sections discuss the results of the interviews in the four different parts of the interview structure. The answers to the open-ended questions are summarised to the key findings. Most of the answers received for the closed-ended questions are transferred to Microsoft Excel to ensure consistent evaluation and presentation of the data.

For analysing the results, the representatives and their organisations are not explicitly referred to, but instead labelled and addressed as bus service A, B, C, and D. Bus services A and B are located in Germany and bus services C and D are from South Africa.

### 4.3.1 Part 1: Acquire Context

Each of the interviewees indicated that their organisations utilise a combination of a reactive and preventive maintenance strategy. All the organisations document

their maintenance using a CMMS system and maintenance practices are initiated by service history data on a kilometre basis.

It is standard practice across all of the organisations to carry out periodic safety checks as required by the respective authorities to ensure that passenger safety is guaranteed. The buses also have to pass roadworthy tests either on a kilometre or time basis depending on the requirements of the respective road agencies. Most of the buses also undergo basic daily inspections to identify any sign of a pending breakdown and to pick up a malfunction before it can worsen. In this sense, it can also be said that CBM is implemented to a certain extent.

### 4.3.2 Part 2: Industry 4.0 Technology Maturity

The maturity levels of Industry 4.0 technologies in maintenance at inner city bus services are presented as a bar chart in Figure 4.1. Each bar represents the number of principal requirements met by each organisation for each technology. If three requirements are met, the technology is regarded as being at a mature level. Meeting one or two of the requirements indicate that the technology has been initiated or is partly operational.

The Industry 4.0 technologies are not at mature levels but at varying levels of initiation. Artificial intelligence is the only technology that has no maturity level. IoT, cloud computing, and CPS have low levels of maturity. Big Data and analytics shows the highest maturity level due to the organisations having a basic capability to collect and store data with some sort of digital data management system. However, they do not perform any data analytics to generate insight.



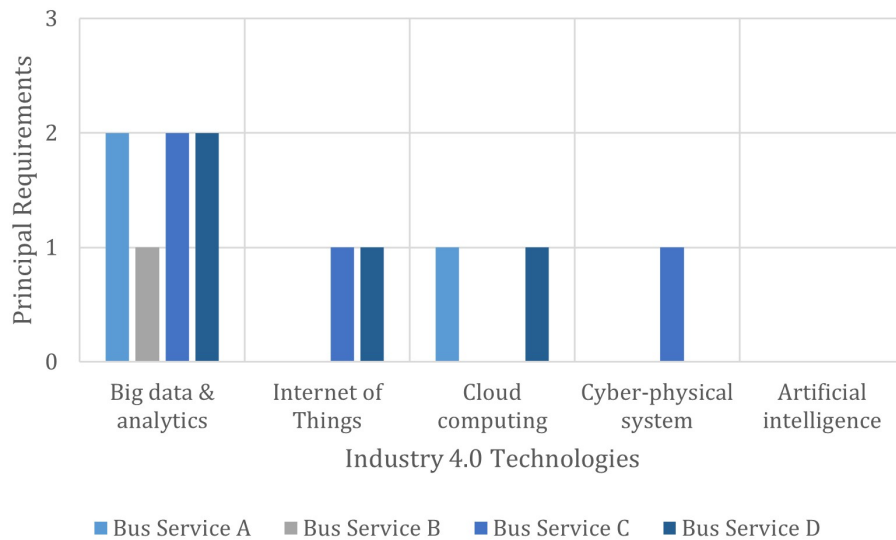

**Figure 4.1:** Maturity level of Industry 4.0 technologies at inner city public bus services

Analysing the Industry 4.0 technology maturity levels shows that there is a lack of digitalisation regarding the technologies utilised in the maintenance practices at inner city bus services. This indicates that their maintenance practices are not close to anything such as smart maintenance.

### 4.3.3 Part 3: Factors Influencing Bus Reliability

The responses regarding the main factors influencing the reliability of an inner city bus are combined and presented in Figure 4.2. Interviewees ranked the factors during the interviews. From the rankings, each factor receives a score. The highest ranking factors get a score of four points and a descending order is followed to the lowest factors that get no points. All the scores are added up to determine which factors are more influential.

It is evident from Figure 4.2 that the most influential factor is being unaware of the health status of the buses. Understandably, the reliability of equipment decreases as it is continuously operated without anyone being aware of its condition.

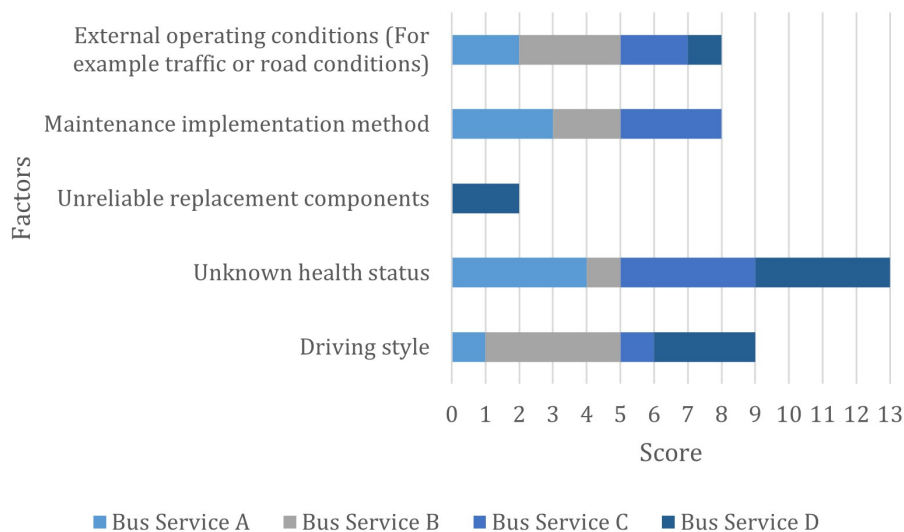

**Figure 4.2:** Factors influencing the degradation in the reliability of an inner city bus

Unreliable replacement components are a smaller influencing factor as, according to the interviewees, the quality of parts from an Original Equipment Manufacturer (OEM) are guaranteed. The results of the open-ended question employed to determine the key components that are responsible for most of the downtime of inner city buses are displayed in Table 4.1. Components causing downtime at bus service D are unknown due to the interviewees from this organisation not having any such information available to them.

**Table 4.1:** Key components responsible for downtime

	<b>Bus Service A</b>	<b>Bus Service B</b>	<b>Bus Service C</b>
1	Exhaust coupling	Door problems	Electric parts (esp. batteries)
2	Air compressor	Air conditioning	Engine
3	Head gasket	-	Gearbox
4	Tyres	-	Axles
5	Faulty sensors	-	Air system

The key components identified in Table 4.1 do not clearly show any correlation between the inner city bus services. Each organisation has different components that lead to downtime for their inner city buses. This can be due to the difference in operating conditions and the different types of buses employed by the organisations. The feedback for how the unit life of the key components can be improved varied from each interviewee. Contrasting answers could also be due to the diverse nature of the identified components and the different levels of expertise of the interviewees. Most agreed that Industry 4.0 technologies can aid in addressing their key components.

The organisations have detailed historical service data available on the key components that they identified. The normal procedure is to document any maintenance activity when something breaks or requires fixing. Varying reasons exist for this data not being incorporated or utilised to generate insight and support decision-making. In some cases, the historic service data is not in usable format and requires manual processing or data handling before it can be used in any digital system. Even if the data were in an acceptable format, the knowledge of what to do with it is lacking.

#### 4.3.4 Part 4: Smart Maintenance

None of the inner city bus services use any form of prognostics; each organisation makes use of diagnostic information in the maintenance of the buses. The preferred period to receive health status updates is between weekly and daily. Organisations would ideally want to know the health status of each of their buses at the end of a shift. It is necessary to know in what state the equipment is by being informed about what parts are close to failure and require attention to ensure reliable operation. One organisation additionally indicated that real-time monitoring would be of interest. Real-time monitoring can be useful when a serious fault arises to activate a live notification to enable quick response times and replacement parts to be prepared.

The important aspects to consider when implementing smart maintenance were ranked by each interviewee and the outcome is shown in Figure 4.3. Each aspect is given a score according to its rank by following the same point awarding approach of the factor ranking question in Section 4.3.3. The total scores are presented to indicate how important each aspect is considered to be. Maturity of technologies is regarded as the most important aspect, with the others being at intermediate levels and data security being regarded as the least important.

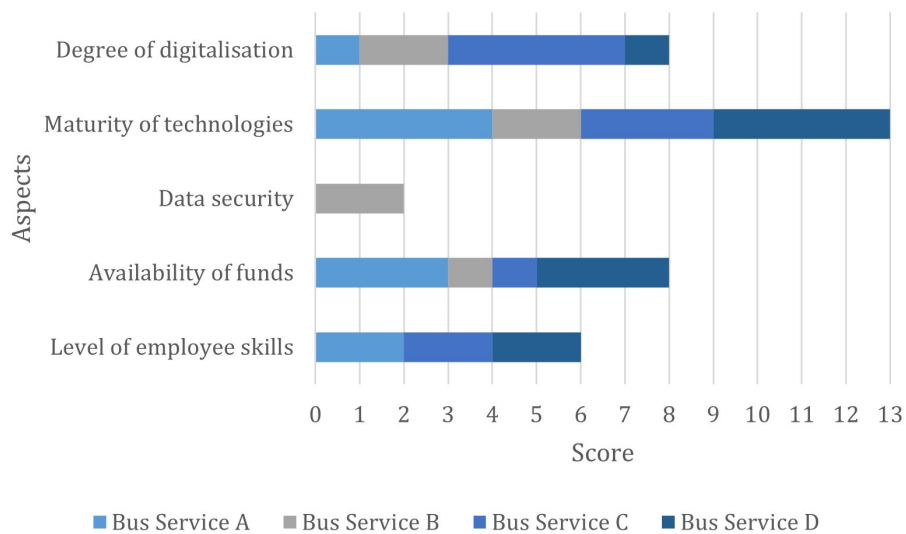

**Figure 4.3:** Aspects to consider for smart maintenance

Figure 4.4 presents the feedback on the importance scores achieved by the different smart maintenance system requirements, showing which are considered of higher priority to form part of the system. On the x-axis of the figure, the numbered requirements are derived from Section 2.1.3 and defined in Question 11 of the Interview Schedule in Appendix A.4. Most of these requirements are within a small range from one another, with two of them being markedly higher than the others. All the requirements are within the upper half of the score range. The feedback shows that all of the requirements are considered essential in forming part of the smart maintenance system.

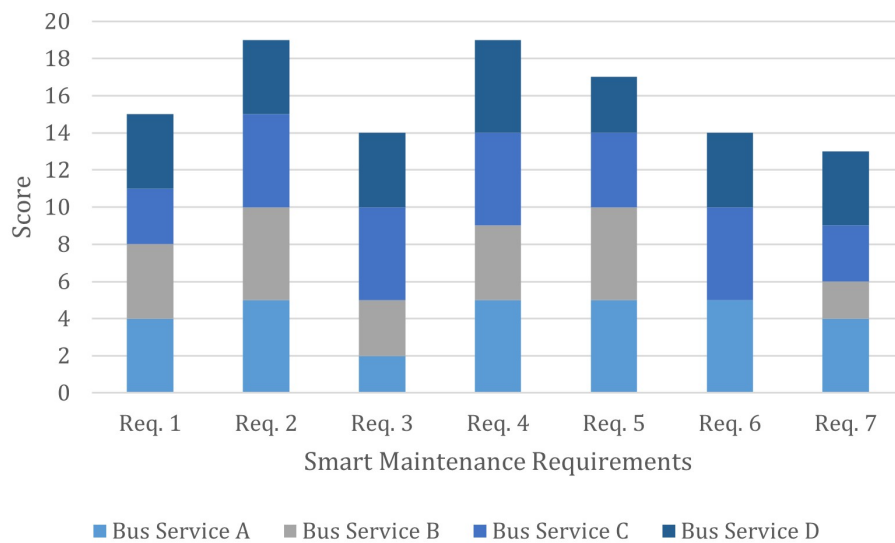

**Figure 4.4:** Importance rating of smart maintenance system requirements

### 4.3.5 Interview Results Discussion

The feedback from the interviews gives insight into the maintenance methods, processes, and technologies utilised in the inner city bus service industry. One of the most determining factors to influence the maintenance strategy and implementation method is the operating context of a specific organisation. Each organisation employs different types and manufacturers of inner city buses as well as varying operating schedules.

In Germany, a bus is assigned to a specific route for the day and operates along that route continuously for approximately 20 hours, only stopping for a maximum of 10 minutes every four hours at certain bus stops to rotate drivers. The German organisations only use hybrid powered buses and are currently moving toward pure electric power units due to strict environmental regulations in Europe. Thus, the inner city buses used in Germany are by default more technologically advanced. The South African buses are mostly powered by diesel engines and operate during peak traffic hours in the morning and afternoon.

Climatic conditions also differ from the below freezing conditions in Europe to a hotter and drier African climate. All the factors mentioned mean that the buses are equipped with different systems and technologies to allow them to cope with their operating environments. The varying operating contexts of the organisations result in diverse causes of downtime, as found in Section 4.3.3. This means that to ensure the smart maintenance system is not organisation-specific, it needs to be adaptable to unique problems identified as causing downtime.

The maintenance methods and processes of the German organisations are not necessarily going to be of value to the South African organisations due to the difference in operational context. Despite the measures already put in place by the organisations to maintain a certain level of reliability and safety of the inner city buses, unexpected breakdowns still occur and certain components are responsible for recurring downtime. These components need to be prioritised by the smart maintenance system to directly address such crucial problems first.

Designing a generic smart maintenance system is not feasible as the key parameters causing downtime of the buses are diverse and organisation-specific. However, this only influences the first phase of the system, where it should be determined what parts to monitor as they are causing downtime. The subsequent phases of the system can be more generalised for the purpose of processing the collected data and supporting decision-making. Problem identification must be included as the first part of the system in order to identify the downtime causing parameters that the system needs to monitor.

Emphasis is placed on being as cost-effective as possible. A comment that came up through all the interviews is that such a system can only be considered if it is financially viable and feasible. Being cost-effective needs to form part of the system design. The inner city bus service industry is mainly oriented around service quality for the customer. Service quality can be assured by the system as it can contribute to the reliable operation of inner city buses.

A mutually agreed upon objective is to reduce the number of backup buses re-

quired. This can lead to cost savings for the organisations by reducing the capital required to maintain an extensive reserve fleet for unforeseen breakdown events. Optimal performance of the smart maintenance system can minimise the need for extensive reserve fleets.

Maintenance teams have data availability, but the data is collected through manual techniques. While data is available to them, there is a lack of knowledge on how to interpret it and the selection of what sensor parameters to monitor and analyse it. Ideally, the maintenance manager wants to be informed if a certain bus requires urgent maintenance at the end of a service day to allow it to continue to be functional. If a certain important part has reached a degraded state, and is at risk of failing, it should be picked up by the system.

Industry 4.0 technologies are at a very low maturity level in the maintenance practices of inner city bus services. Implementing Industry 4.0 technologies that support smart maintenance can increase the efficiency and effectiveness of maintenance in this industry. Digitalisation of the maintenance approach holds advantages for all stakeholders.

## 4.4 Chapter Summary

In this chapter, an empirical investigation is undertaken to collect supplementary data for this research. The method used involves structured interviews conducted with four interviewees in a maintenance manager-type position at separate inner city bus services in Germany and South Africa. Feedback from the interviews held with the organisations reinforces that there is indeed an opportunity to develop and test a smart maintenance system for inner city buses. The findings in this chapter are used in the following chapter to set up the smart maintenance system requirements and to develop the system.

## Chapter 5

# Smart Maintenance System Development

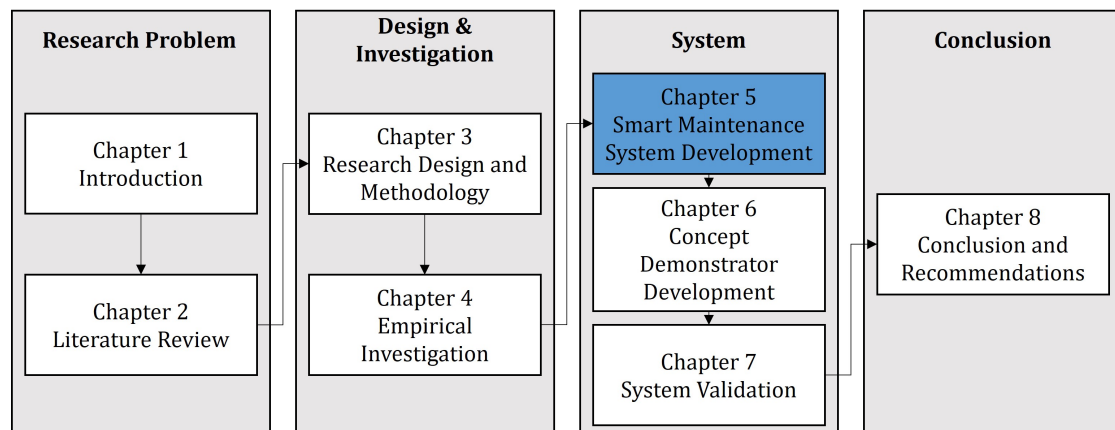

The development of the smart maintenance system is introduced in this chapter. The system's requirements are specified and explained first, followed by the system's functions. Finally, the hardware and software for the smart maintenance system are selected to develop a concept demonstrator for validating the smart maintenance system.



## 5.1 System Requirements

The requirements of the smart maintenance system are configured based on the findings of the literature review in Chapter 2 and the results of the empirical investigation in Chapter 4. All the requirements are aimed at minimising the downtime of inner city buses and to ensure their reliable operation. The requirements are defined in Table 5.1 and classified by type in terms of being an essential or optional requirement. Requirements that are labelled as essential are crucial for the successful functioning of the smart maintenance system. By way of contrast, the optional requirements are not a prerequisite for the successful operation of the system but allow for refinement.

The requirements start with the first part being data collection. An essential requirement is to identify the key parameters responsible for the most downtime, thus addressing the main issues while not being organisation-specific. Correspondingly, the ability to collect sensor data from the key components of the inner city buses is an essential requirement. Included as an optional requirement is the ability to establish a connection to the vehicle's ECU, through the OBD system and J1939 protocol for heavy duty vehicles, to allow for easy access to any sensor readings and DTCs. Connecting to the ECU is optional for when one of the key parameters is already monitored by a vehicle's ECU and the sensor data can be extracted from it.

Processing data allows for remote and online monitoring. To wirelessly transfer data realises this requirement and it is seen as essential. Another data processing requirement is to only allow data transfer at preferred intervals to avoid unnecessary data transfer. Sensing frequency has to be selected based on the nature of the component being monitored and the number of sensor readings required to make an accurate judgement of a component's health state.

Performing analytics on the data received from the monitored assets is another important part of the requirements for the system. Detecting faults from the gathered data is essential for the system to feature diagnostic capability. After a fault is detected, the type of fault must be identified. For instance, it can be classified

as an urgent fault that requires immediate attention or semi-urgent, requiring attention at the next scheduled service. Remaining useful life estimation is essential in establishing a prognostic approach in maintenance. Relevant wear models to predict remaining useful life can be implemented based on the key parameters identified, as parts may have different suitable wear models. Utilising cloud computing to analyse the data and perform computations is an essential requirement to strive towards the system acting autonomously.

Visualising the data and knowledge discovered from analysing the data produces more requirements. Presenting the data using a Graphical User Interface (GUI) is seen as essential to facilitate easy access and promote user-friendliness. It must be accessible from PCs, tablets, and smartphones, providing easy system access to the maintenance workshop and depots. Accessibility from any location means that manufacturers and experts can view the system parameters to provide support if necessary. Indicating an anomaly is essential to notify the responsible people that a key component on a certain bus has reached a degraded state and requires maintenance. Anomaly indication can be done by creating a notable notification on a screen in the workshop or through automated email and SMS notifications. Displaying system parameters continuously is not crucial, but must be provided upon request from a user input. Managing the accessibility of historic values is essential for the investigation of root causes to faults and degradation patterns.

Supporting data-driven decision-making is where the system can have a crucial influence. The characteristics for conducting bus maintenance in an efficient way, identified in Section 2.3.3 of the literature review, are added as essential requirements for decision support. The requirements are:

- Identify buses from the fleet.
- Define when and where to perform maintenance.
- Classify what maintenance tasks to perform.
- Assign resources and spare parts.

The system incorporates these requirements to effectively support the maintenance personnel in efficient decision-making, forming the upper layer of the system.

Updating the workshop daily on the health status of the buses is preferred above continuous real-time monitoring, as determined in Section 4.3.4 of the previous chapter. Health status updates must indicate at the end of a service day which buses and their key components are trending towards or have reached a degraded state that may lead to failures and require maintenance scheduling. Using service records to narrow down a problem identified when something fails is added as optional, due to it being dependent on the quality of data available from an organisation and the type of component.

Being cost-effective is one of the desired requirements identified from the empirical analysis results discussion in Section 4.3.5. To promote cost-effectiveness, the system must be able to integrate into the existing infrastructure of an organisation and develop further on that basis. Minimum training should be required to operate the system to keep costs low and eliminate the need to hire new employees. These requirements are all seen as essential due to cost-effectiveness having a high priority.

It is desirable for the smart maintenance system to be applicable to other inner city bus services and be generalised through not being specifically designed for a certain organisational structure. The system must also be adaptable by allowing for integration of additional functions as technologies develop further.

Lastly, it is a basic requirement that the system should manage an essential level of security. Security can be realised by establishing a secure network connection and storing the system data safely. Both of the security requirements are seen as essential.

**Table 5.1:** Smart maintenance system requirements

Requirements		Type	
1	Data collection	Identify key parameters	Essential
		Sensor data collection	Essential
		Vehicle ECU Access	Optional
2	Data processing	Wireless data transfer	Essential
		Data transfer in preferred intervals	Optional
3	Data analysis	Detect and identify faults	Essential
		Remaining useful life estimation	Essential
		Cloud computing	Essential
4	Data visualisation	GUI	Essential
		Indicate anomaly	Essential
		Display system parameters	Optional
		Accessibility of historic values	Essential
5	Decision support	Identify buses from the fleet	Essential
		Define when and where to perform maintenance	Essential
		Classify what maintenance tasks to perform	Essential
		Assign resources and spare parts	Essential
		Daily health status updates	Essential
		Use service records to narrow down problem	Optional
6	Cost-effective	Integrate into existing infrastructure	Essential
		Minimal training required	Essential
7	Adaptable	Support different organisational structures	Essential
		Able to integrate additional functions	Essential
8	Security	Secure network connection	Essential
		Store data safely	Essential

## 5.2 System Functions

The functions of the smart maintenance system are defined in this section. The features of the system are based on the smart maintenance planning system discussed in Section 2.1.3 and the predictive maintenance fleet management system in Section 2.5.3. Characteristics of the CPS system discussed in Section 2.2.4 are also incorporated. First and foremost, an identification step must take place to identify the key parameters of the inner city buses causing the most downtime. The problem identification step is not seen as a function, but as a preparation phase before installing the system.

### 5.2.1 Condition Monitoring System

The system starts with its foundation as the perception layer, Figure 5.1, where the system functions consist of condition monitoring features. Suitable sensors capture information about the current state of a bus by monitoring the identified key parameters. Access to the vehicle's ECU is established if ECU sensor readings are required. Measurements are taken automatically and sensor signals are gathered and undergo initial processing. Preparation for the signal readings to be transferred is performed, after which the data transmission is carried out at set intervals.

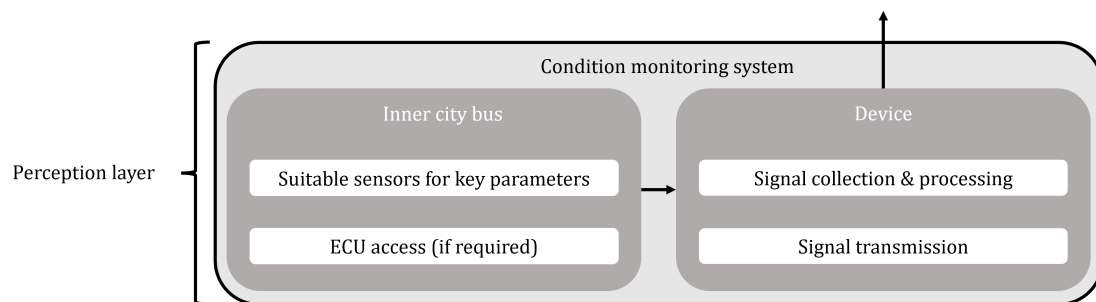

**Figure 5.1:** Condition monitoring functions of the system

### 5.2.2 IoT Network

At the centre of the system is the middleware layer, consisting of IoT characteristics that exist in a cloud environment, as shown in Figure 5.2. CPS functions are incorporated to facilitate the connection between the physical and digital world. Wireless data transmission is performed using Wi-Fi and a typical transport protocol, such as Message Queuing Telemetry Transport (MQTT) or HTTP. A connected equipment network is established, connecting the bus fleet of an organisation to the system. Measured values retrieved from the fleet are stored in the cloud environment.

The diagnostic and prognostic function identifies faults and predicts the health status of equipment, realised through classification and predictive algorithms commissioned in the cloud. What classifies a sensor value to indicate a fault and which algorithms are suitable for lifetime estimations depends on the key parameters being monitored. Identified faults are analysed and categorised into what sort of risks they encompass, classified by urgency. Urgent risks are flagged to be prioritised for maintenance scheduling.

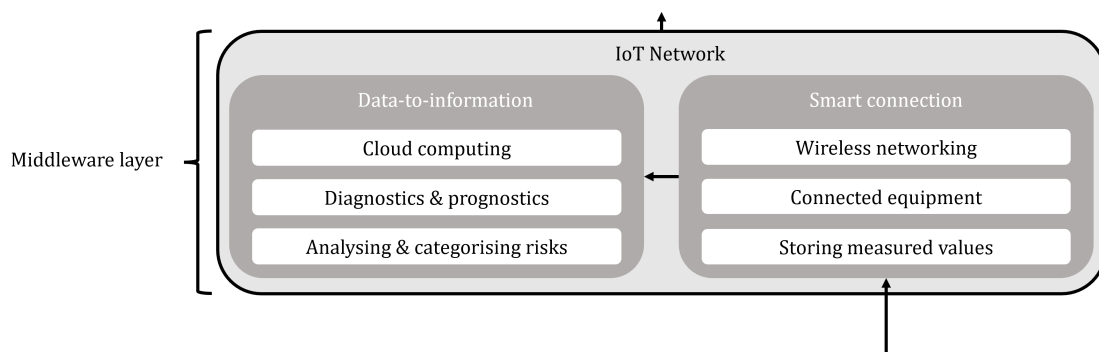

Figure 5.2: IoT functions of the system

### 5.2.3 Smart Maintenance Planning

In the application layer shown in Figure 5.3, the functions are aligned to support data-driven decision-making with regard to smart maintenance planning. The

system transitions back from the digital world to the physical world, where the optimised maintenance decisions are implemented on the equipment. The outcome and results of the lower layers of the system are used to generate insight that is presented in a suitable way to help the user make informed decisions.

Malfunctioning buses are identified from the fleet and the system specifies where and when to perform maintenance. The system provides an indication of which service bay or depot area is suitable to address the fault. The previous layer classified the urgency of the risk of a fault; accordingly, urgent risks are scheduled to require immediate attention when a bus finishes its shift, whereas less urgent ones are appraised to be checked at the next service interval.

Through maintenance planning the system must specify the correct maintenance tasks linked to an identified fault. Specifying the tasks must be accompanied by the required spare parts to make sure that the parts are ready when the maintenance activity is commenced. These tasks and required parts can be defined by a maintenance specialist beforehand or from the service records. Service records can be linked to the system if in usable format, allowing the system to perform automated service scheduling for unforeseen events in conjunction with the standard service protocol.

Notifications are sent to the relevant maintenance personnel about equipment in critical condition and components that have reached the end of their life. These notifications are communicated through email and SMS. Health status updates are provided on a daily basis to indicate which units are close to reaching a degraded state or have experienced malfunctions during a shift. Maintenance personnel are provided with all the important information from the smart maintenance planning functions through a GUI on a computer screen or tablet in the workshop.

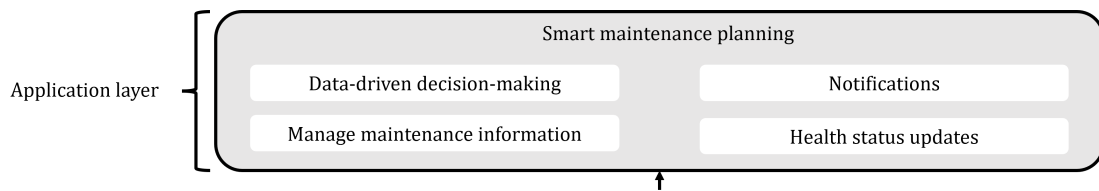

Figure 5.3: Smart maintenance planning functionality

### 5.2.4 Smart Maintenance System

The complete architecture of the smart maintenance system for inner city public bus services is shown in Figure 5.4. It can be seen where the different layers interact and how the system functions are positioned.

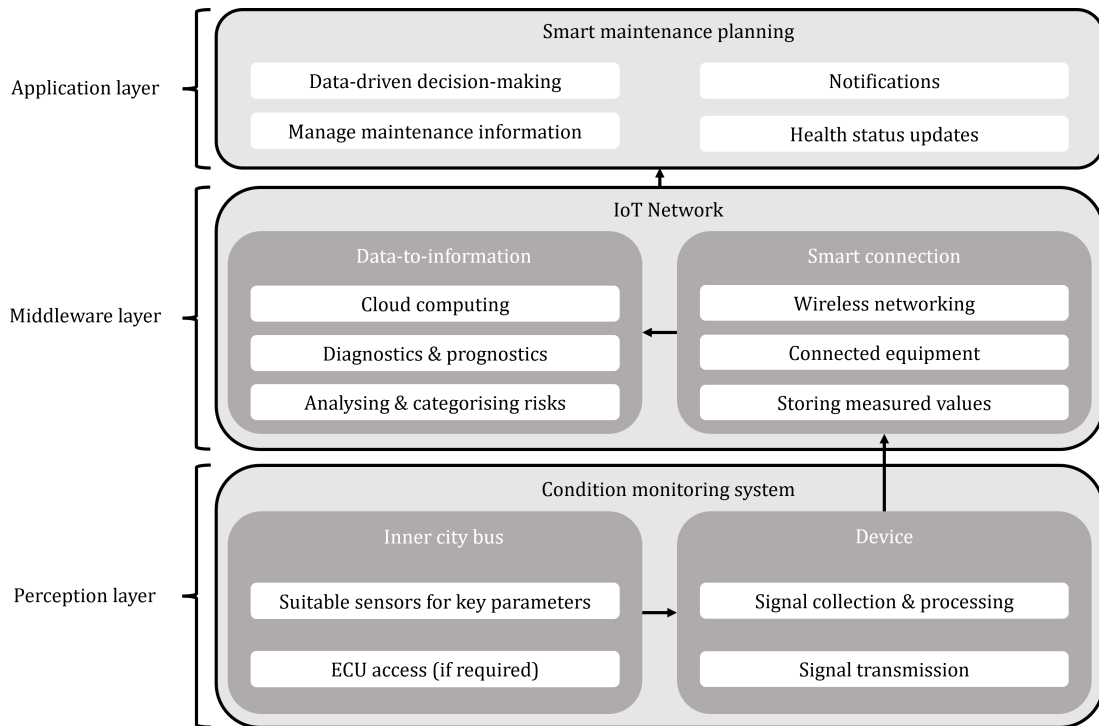

Figure 5.4: Architecture of the smart maintenance system for inner city public bus services



## 5.3 Concept Demonstrator

In this section, the design approach of the concept demonstrator is described. The hardware and software for the demonstrator are selected and discussed. The purpose of the concept demonstrator is to validate the smart maintenance system. For validation, the concept demonstrator addresses the main problem of a certain organisation. The key parameters responsible for the most downtime vary from each organisation, as found by the empirical analysis results in Section 4.3 of the previous chapter. The concept demonstrator is set up to monitor the key parameter, bus batteries, of bus service C, as shown in Table 4.1.

Developing the concept demonstrator for bus service C is motivated by the aim of forming an adaptable solution that can be adjusted to be applicable to the problems identified by other inner city public bus services. The demonstrator that is designed can be reconfigured without extensive design work to monitor other key components identified for causing downtime of inner city buses. Relevant sensors would have to be included to monitor other components and the appropriate diagnostic and prognostic software to generate insight into the health statuses of these components. Considering the rationale for designing the concept demonstrator for the specific organisation confirms that the decision is made based on practicality, genericness, and adaptability. Other factors that were also considered were the willingness of the organisation to participate in the research and easy accessibility.

### 5.3.1 Demonstrator Design Approach

In the process of constructing a concept demonstrator, it is necessary to first recognise the fundamentals it is based on. The smart maintenance system requirements and architecture defined in the previous sections are used to configure the concept demonstrator for the case study organisation. Initially, a preparation phase is required where the key parameters for causing the most downtime should be identified. This initial phase is not performed as this step has already been taken in the selection of bus service C, where the key parameters are already known. The

outcome of the demonstrator design is a system that addresses the main problem of this specific organisation. Bus service C mainly experiences problems with their buses' electrical systems and, more specifically, the bus batteries that discharge without warning, rendering buses out of service during crucial times. Failures in the power supply systems of vehicles are sudden and unexpected since on-board diagnostics do not allow for their early detection (Puzakov, 2020).

The addition of operational power supply system monitoring can improve vehicle operation effectiveness by decreasing repair-related downtime, which is crucial for the operation of vehicles used for services that demand a high level of technical readiness (Puzakov, 2020). With the background and purpose of the demonstrator known, the next step is to determine the elements that make up the demonstrator system. Components must be selected that are able to reflect the capabilities set out by the smart maintenance system requirements and functions included in the architecture. After understanding the approach to designing the demonstrator system, the hardware and software selection can commence.

### 5.3.2 Hardware & Software

The hardware and software for the concept demonstrator are specified and discussed in this subsection. The device selection, the accompanying sensor, and other circuit components are discussed first. Subsequently, the software for the implementation is selected. All selections are made according to the defined requirements and architecture of the smart maintenance system.

The device selected is the *NodeMCU ESP8266* Wi-Fi development board. The selection is motivated by the ability of the device to support the required functionality of the concept demonstrator. *NodeMCU* is an open-source platform based on the *ESP8266* that allows things to be connected and data to be transferred using the Wi-Fi protocol, permitting the realisation of IoT applications.

Monitoring the status of a battery is done by analysing the battery voltage

level (Tan and Tiew, 2014). Sensing voltage can be done through using a voltage divider to reduce the voltage down to the sensing range of the microcontroller. Input voltages to any of the device sensing pins are limited from 0 V to 3.3 V (Espressif, 2020). The design of the sensor is presented in Chapter 6.

The *ESP8266* is embedded with a 10-bit precision analogue to digital converter accessed through the A0 (TOUT) pin (Espressif, 2020). The resolution of the 10-bit converter is determined in Equation 5.3.1 by dividing the input voltage range by the number of possible values ( $2^N$ ) (Escabi, 2012). The input voltage range is 3.3 V (0 V to 3.3 V) and N is the number of bits. The resolution means that the system can measure an input voltage to an accuracy of 3.22 mV, which is sufficient for the purpose of the concept demonstrator.

$$\frac{V_{input-range}}{2^N} = \frac{3.3V}{2^{10}} = 3.22mV/bit \quad (5.3.1)$$

To create a cloud environment, the software application *ThingSpeak* is suitable. *ThingSpeak* is a cloud-based IoT analytics software program that lets the user aggregate, visualise, and analyse live data streams. The application is open-source and functions as an Application Programming Interface (API) used to store and retrieve data from connected things using HTTP over the internet or via applications (Yazed and Mahmud, 2017). Data can be submitted from devices to *ThingSpeak*, where real-time visualisations of live data can be generated and notifications issued.

The last tier in the concept demonstrator is to commission service notifications. The *IFTTT* software is selected to fulfil this role. *IFTTT* is named after the programming conditional expression “if this, then that”. *IFTTT* is a software platform that connects multiple applications, devices, and services in order to activate automations involving those applications, devices, and services (Martin and Finnegan, 2020). To understand the working flow of the concept demonstrator

refer to Figure 5.5.

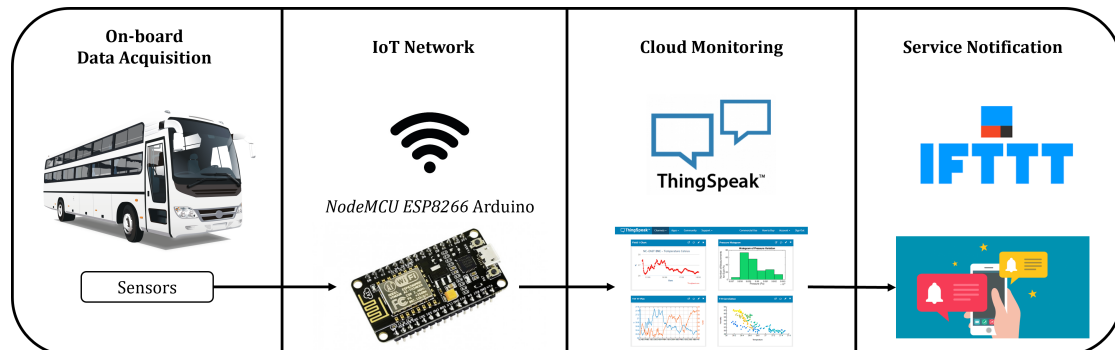

**Figure 5.5:** Concept demonstrator configuration

In Figure 5.5, it is shown that sensors are used for on-board data acquisition on a bus. Data is collected from the sensors by an IoT device that establishes an IoT network to send the sensor data to the cloud environment. From analysing the data in the cloud environment, maintenance notifications are issued.

## 5.4 Chapter Summary

The requirements for the smart maintenance system are set out and defined in this chapter. The system functions are discussed and configured to form a complete system. The hardware and software are selected for the development of a concept demonstrator for the smart maintenance system. Further development continues in the following chapter.

# Chapter 6

## Concept Demonstrator Development

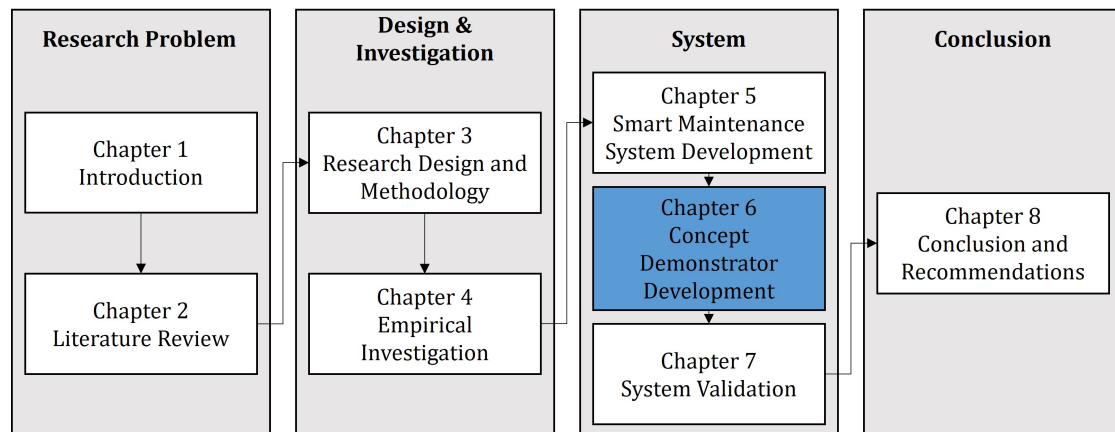

In this chapter the concept demonstrator, representing the smart maintenance system, is assembled from the selected hardware and software. The hardware setup is discussed first, followed by the software setup. Lastly, the experiment is designed to test the functionality of the concept demonstrator for the ultimate purpose of investigating the feasibility of the smart maintenance system.

## 6.1 Concept Demonstrator Setup

The hardware and software setup of the concept demonstrator is covered in this section. It is necessary to understand how the hardware and software are aligned to construct a functioning system.

### 6.1.1 Hardware Setup

The hardware setup of the device starts with fabricating a suitable voltage sensor. The voltage sensor is custom built due to the lack of a compatible sensor for the microcontroller in the local market. The analogue input terminal of the *NodeMCU ESP8266* may not be supplied with more than 3.3 V (Espressif, 2020). The sensor is therefore configured as a voltage divider to reduce the sensed voltage down to an acceptable level for the microcontroller.

A voltage divider is a linear circuit that divides an input voltage by a certain ratio to produce an output voltage (Fransiska *et al.*, 2013). It can be set up by connecting two resistors in a circuit, as illustrated in Figure 6.1. Equation 6.1.1 defines the resistive voltage division.

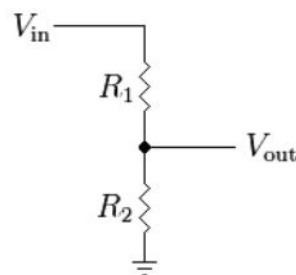

**Figure 6.1:** Voltage divider circuit (Fransiska *et al.*, 2013)

$$V_{out} = \frac{R_2}{R_1 + R_2} V_{in} \quad (6.1.1)$$

The resistors and wires are soldered onto a board, as shown in Figure 6.2, ensuring the parts are securely fastened and that all the connections are durable. Determining the suitable resistors used for the voltage divider is done by considering what resistors are available and the fact that it should divide the sensed voltage down to below 3.3 V. The first resistor has a resistance of a 1000 Ohm and the second one a resistance of 100 Ohm. Choosing these resistances results in the sensed voltage being reduced by a factor of eleven, calculated by using Equation 6.1.1, proving to be sufficient for reducing the operating range of a 24 V battery below 3.3 V. The resistors used are specified to have a tolerance of 5% and in order to increase the voltage sensor's accuracy each resistor's resistance is measured with a multimeter. Resistor one is 981 Ohm and resistor two is 99 Ohm. The measured resistances are used in the voltage division equation.

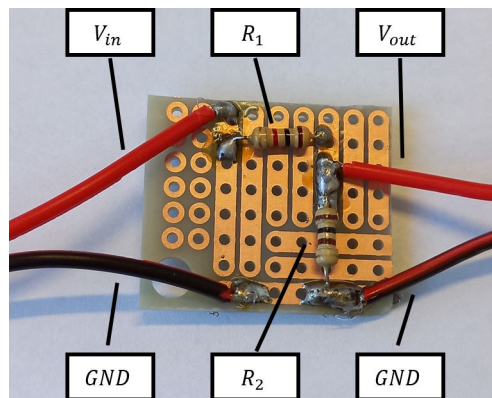

**Figure 6.2:** Concept demonstrator voltage divider circuit

The *NodeMCU ESP8266* requires a 5 V power supply (Espressif, 2020). Power is supplied from the 24 V bus battery. During normal operation, the device only draws an average current of 80 mA (Espressif, 2020), meaning that it has a negligible effect on the battery. The voltage regulator, Figure 6.3, is a stock part bought from an electronics shop and supplies the microcontroller with a constant 5 V irrespective of the input voltage. Wires connecting to the ground and input voltage terminals are soldered into place.

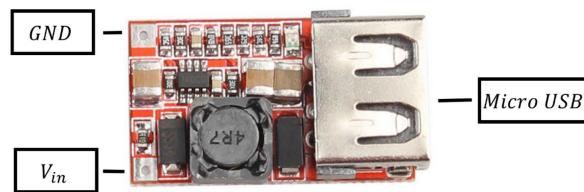

**Figure 6.3:** Concept demonstrator voltage regulator

The voltage sensor, Figure 6.2, and voltage regulator, Figure 6.3, are connected to the same input voltage and ground connection coming from the bus battery. Definitions of the multiple pins of the *NodeMCU* are given in Figure 6.4. The output voltage of the voltage sensor is connected to the analogue pin (A0) and the ground is connected to any of the microcontroller ground pins. Power is given to the device through the micro USB port by the voltage regulator. The device is put in sleep mode when it is not required to transfer signals. From the hardware side, the sleep function is activated by connecting pin D0 to the RST pin.

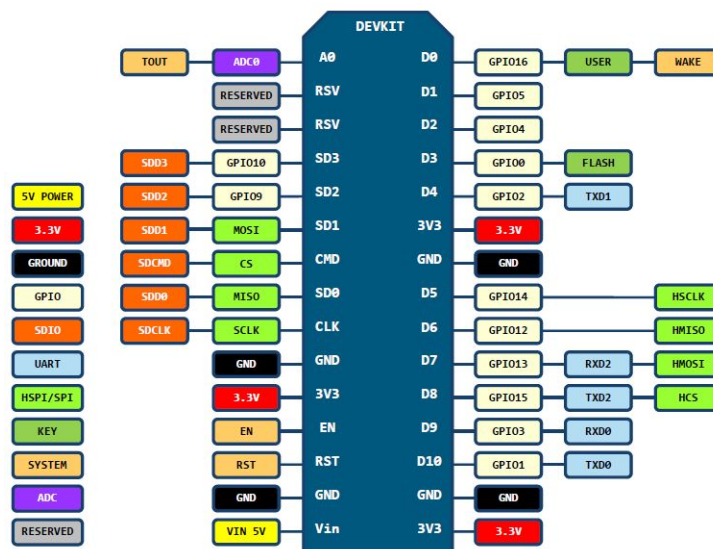

**Figure 6.4:** *NodeMCU ESP8266* Pin definition (Espressif, 2020)

Figure 6.5 represents the complete layout of the concept demonstrator hardware, showing how all the different components are connected. To protect the system from possible power surges, a 1 A fuse is connected into the circuit. This



minimises the risk of accidentally causing a fire when the system is exposed to unexpectedly high input.

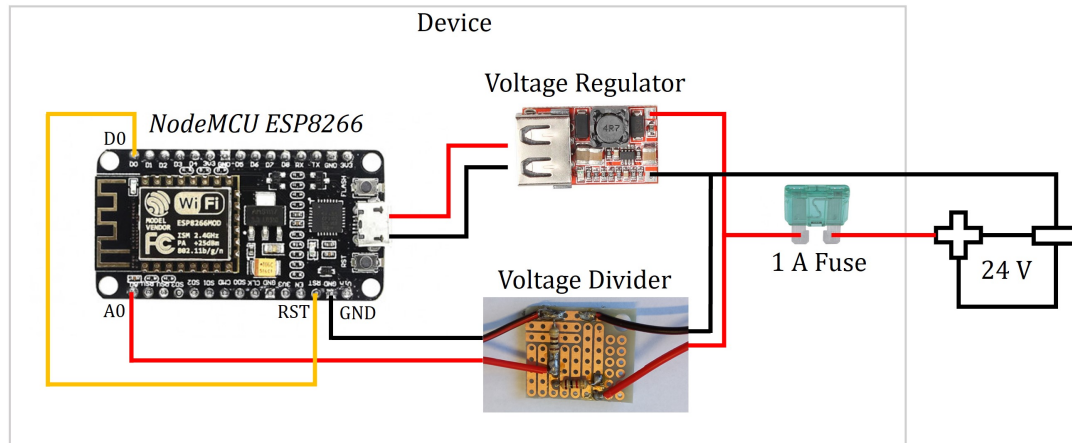

Figure 6.5: Concept demonstrator layout

### 6.1.2 Software Setup

The microcontroller is not pre-programmed and requires coding from first principles to enable it to perform the desired functionalities. Arduino code is written in the C++ coding language with some additional special functions and methods. The code is written in the Arduino Integrated Development Environment (IDE) text editing program, where the code is typed out before it is uploaded to the device.

The logical flow of how the code executes is presented in Figure 6.6 as a logical flow diagram and the full script is included in Appendix B.2. After starting, the device seeks to connect to the strongest Wi-Fi signal available by iterating until it has found the strongest signal. The next step is to sense the analogue input reading from the voltage sensor. From the analogue input, the 10-bit converter produces a digital signal. Dividing the signal by  $2^{10}$  converts it back to analogue and the battery voltage is calculated by inverting Equation 6.1.1. The computed battery voltage is checked if it is lower than or equal to a certain value. If it is lower, the

device waits five minutes until it reads and computes the battery voltage again before it sends the reading to the cloud. The voltage checking loop is included to eliminate the chance of an engine startup being identified as a draining battery. If the voltage is found to be higher than the pre-defined voltage, it continues past the checking loop to send the voltage measurement to the cloud. Finally, the device enters sleep mode for thirty minutes, after which it awakes and the entire process starts again. A frequency of 30 minutes is selected due to the fact that the battery gradually decays and smaller intervals may be unnecessary.

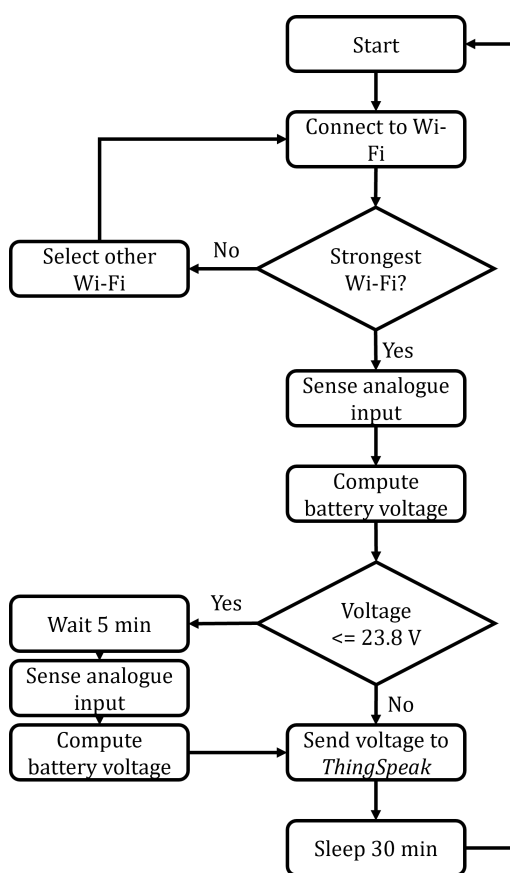

**Figure 6.6:** Flow diagram of code logic

The bus battery that is monitored consists of two 12 V lead-acid batteries connected in series, which adds up to 24 V. The voltage level at which a battery cannot reliably start an engine depends on several factors, but the general guide

is to check a 12 V battery when it reaches a voltage lower than 11.9 V (Lokithor, 2021; Veldboom, 2021). At this voltage level, the battery has reached a state of charge lower than 50%, resulting in a significant decrease in performance (Lokithor, 2021; Veldboom, 2021). The voltage level of concern for the 24 V setup that is going to trigger a notification is calculated by adding up 11.9 V for both of the batteries to equal 23.8 V.

The system transfers signals from the device by sending HTTP protocol messages across Wi-Fi to the cloud platform. With the data safely stored on the *ThingSpeak* cloud IoT platform, it can be visualised and used to generate insight. An appropriate interface is arranged in *ThingSpeak* to visualise the data stream and help maintenance personnel interpret the data quickly. Its layout is presented in the following chapter. The interface can be shared with anyone with the internet link and password. To initiate a response when the battery voltage is equal to or below the determined threshold, a react function is configured in *ThingSpeak*, as shown in Figure 6.7. The react function connects to *IFTTT* via a unique API key and internet address. The function sends a message to *IFTTT* that a certain event has occurred.

Name:	Bus Battery Voltage Notification
Condition Type:	Numeric
Test Frequency:	On data insertion
Last Ran:	2022-05-17 14:58
Channel:	<a href="#">Battery Voltage Monitoring</a>
Condition:	Field 1 (Battery Voltage) is less than or equal to 23.8
ThingHTTP:	<a href="#">IFTTT Notification for Battery Voltage</a>
Run:	Each time the condition is met

**Figure 6.7:** *ThingSpeak* react function

The *IFTTT* software is programmed to generate a notification when it receives the message that the battery has reached a low voltage state. Setting up the maintenance notification message can be seen in Figure 6.8. The notification identifies the fault and what bus is experiencing the fault. It also specifies when, where, and how to address the issue. The variables “EventName” and “OccuredAt” are automatically filled with the event name, battery voltage low, and the current time and date when the notification is activated. The bus identifier can be specified when two or more buses are being monitored. To demonstrate the notification function, it is set to send the message to a mobile phone through the *IFTTT* application.

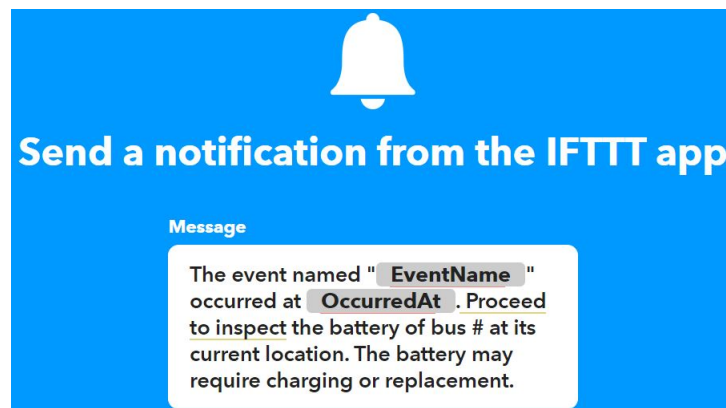

Figure 6.8: *IFTTT* notification configuration

## 6.2 Experiment Design

Designing the experiment is described in this section. Experiment design is the process of planning, designing, and analysing an experiment to draw valid and objective conclusions in an effective and efficient manner (Antony, 2003). The experiment is designed to define the testing procedures for the concept demonstrator that provides structure to the intended case study. Antony (2003, p. 31) states that the methodology for experiment design is divided into four primary phases:

1. Planning phase: Recognise the problem and define variables or design parameters.

2. Designing phase: Select the most appropriate design for the experiment.
3. Conducting phase: The planned experiment is carried out and the results are evaluated.
4. Analysing phase: Analyse and interpret the results in order to draw valid and sound conclusions.

First, the planning phase is considered. Recognising the problem, one would refer back to the motivation behind developing the concept demonstrator to validate the functionality of the smart maintenance system. The only variable or parameter is the battery voltage level, which is monitored by the concept demonstrator.

Influencing factors that are uncontrollable and may originate from the operating environment include vibrations, fluctuating temperature, and water exposure. These elements are mitigated by placing the hardware of the device in a dust and waterproof container. To ensure safety in industrial operations, appropriate safety procedures must be followed (Cao *et al.*, 2019). The safety measures for the experiment are:

- Make sure the ignition key of the bus is removed before installation.
- Properly insulate and fasten all electrical connections.
- Fasten the wires connected to the battery power supply securely, to prevent them from touching each other.
- Place device where it cannot cause any interference to the operation of the bus.
- During installation or testing, use the correct personal protective equipment.

Continuing with the experiment design methodology, the design phase is considered. The extensiveness of an experiment depends on the number of factors to be studied, the factor levels, budget, and resources provided to carry out the experiment (Antony, 2003). The experiment design consists of the test cycles in

Table 6.1.

**Table 6.1:** Concept demonstrator test cycles

Test Cycle	Description
Accuracy test	Supply the device with three different voltages typical to the operating voltage of a bus battery [24 V, 26 V, 28 V]. Compare actual and system measurements.
Notification test	Lower the supply voltage below the 23.8 V threshold to test if notifications are issued to the correct destinations.
Operational test	Let the system run for 2-3 days on a bus, completing normal shifts to observe the system's functionality.

For the accuracy and notification test, power is supplied to the device with a DC bench power supply. The voltages 24 V, 26 V, and 28 V are selected for the accuracy test to fall within the typical operating voltage range of a 24 V bus battery, fluctuating from 24 V to just below 29 V (Lokithor, 2021; Veldboom, 2021). The accuracy test is to check how accurately the system can monitor the battery voltage. To ensure the system issues the correct notifications to preferred destinations, the notification test is included. Testing if the system can function in the operating environment of an inner city bus is done through the operational test. The experiment conduction and analysis phases are covered in Chapter 7 as part of the case study for validating the system.

### 6.3 Chapter Summary

The hardware and software setup of the concept demonstrator, portraying the smart maintenance system, is set out and discussed in this chapter. Furthermore, the experiment is designed that defines the testing procedures for the concept demonstrator. The designed experiment is carried out in the following chapter as part of the case study.

# Chapter 7

## System Validation

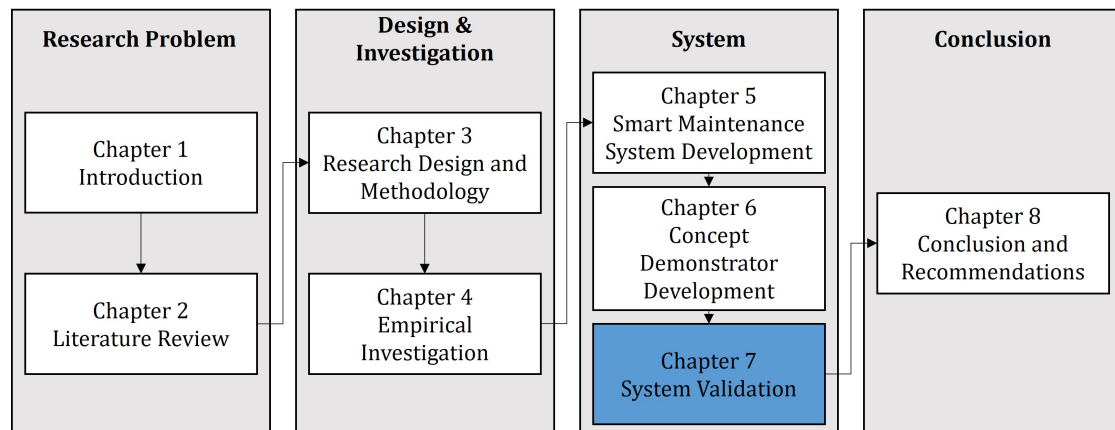

A case study is conducted and presented in this chapter to validate the smart maintenance system. Testing the concept demonstrator is done by executing the designed experiment. The results are discussed, and the system is evaluated. At the conclusion of this chapter, suggestions are made on possible refinements to the system.

## 7.1 Concept Demonstrator Case Study

The case study approach distinguishes itself as a research technique by examining a current phenomenon in its real-life context, particularly when the borders between the phenomenon and its context are not clearly visible (Yin, 1981). The central concept in Yin's definition is that of a boundary, and it should be acknowledged that this boundary is uncertain (Dumez, 2015). A case boundary can be determined empirically or abstractly, from a class defined by a theory, an ideal-type, or an observational situation (Dumez, 2015). Another definition of a case study defines it as "an intensive study of a single unit for the purpose of understanding a larger class of (similar) units" (Gerring, 2004). Conducting the case study gives additional insight into how the system can be applicable to other cases.

The case study is performed by carrying out the designed experiment with the concept demonstrator. Accuracy, notification, and operational tests are conducted. Results documented from the experiment are used to determine which functionalities of the smart maintenance system are satisfied in order to validate its feasibility. O'Leary *et al.* (1990, p. 51) define validation as the process of assessing whether a concept accurately mimics a real-world system in a certain field. The case study is conducted at an inner city bus service situated in Cape Town, South Africa. As previously mentioned, the motivation behind addressing the key issue of the specific bus service is based on the practicality, genericness, and adaptability of designing a concept demonstrator for this particular case.

The microcontroller requires Wi-Fi to load live data onto the cloud platform. A Wi-Fi router is supplied by the electronics department of the organisation for use during testing. The organisation is currently testing this type of Wi-Fi router to supply passengers with internet connectivity, making it ideal for the experiment. Figure 7.1 shows the router and device being prepared for the accuracy and notification test by connecting it to a DC bench power supply at a workstation.





**Figure 7.1:** Testing with DC bench power supply

The first test performed is the accuracy test, where the device is supplied with three different voltages typical to the operating voltage of a 24 V bus battery. Table 7.1 documents the voltage readings where it can be seen that the device has an undesirable deviation between the actual and cloud readings. This deviation can be caused by some of the components or connections in the device circuit.

**Table 7.1:** Concept demonstrator accuracy test before calibration

	<b>Voltage Supplied</b>	<b>Cloud Reading</b>	<b>Accuracy</b>
1	24 V	24.85 V	96.46%
2	26 V	27.03 V	96.04%
3	28 V	29.08 V	96.14%

To eliminate the existing deviation, a calibration factor is calculated by taking the average of the three voltage deviations (0.85 V, 1.03 V, 1.08 V) from the measurements presented in Table 7.1. The factor is calculated to be 0.99 V and is subtracted from the voltage sensed by the analogue input of the microcontroller. This is a reasonable solution to improve the device's accuracy due to the deviations in Table 7.1 being close together. After including the calibration factor in the voltage calculation equation code, the device accuracy increased to above 99%, as seen in Table 7.2.

**Table 7.2:** Concept demonstrator accuracy test after calibration

	Voltage Supplied	Cloud Reading	Accuracy
1	24 V	23.86 V	99.42%
2	26 V	26.01 V	99.96%
3	28 V	28.16 V	99.43%

After the device accuracy is confirmed to be satisfactory, the notification test is performed. The voltage supplied to the device by the DC bench power supply is lowered below the 23.8 V threshold to trigger the notification activation. For testing, the maintenance notification destination is a mobile phone, and the successful reception of the notification can be seen in Figure 7.2. This provides verification that the software applications of the demonstrator system are able to establish a functioning communication network.

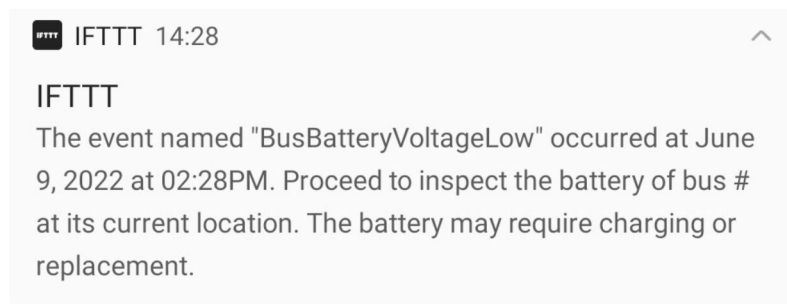
**Figure 7.2:** Mobile phone application notification

An operational test concludes the experiment and the proceedings of the case study. For this test, the Wi-Fi router and device are installed on an inner city bus. Figure 7.3 shows the router and device ready for installation. A qualified electrician installed the device in the back of the driver's cab, where it is connected to a cable with constant battery power. The cloud interface on *ThingSpeak* successfully displayed the first signal pulse received, indicating that the router and device are installed correctly and that the operational test can commence.

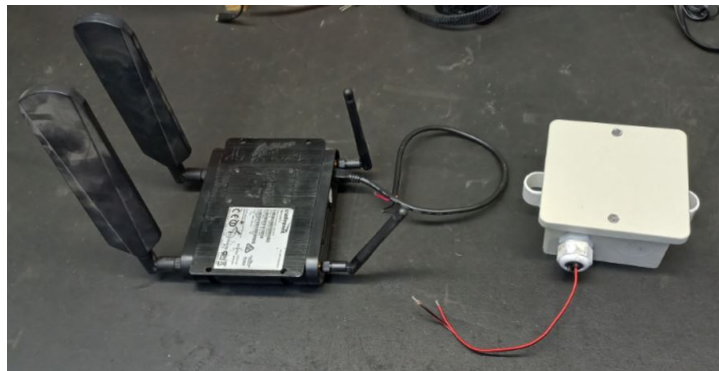

**Figure 7.3:** Wi-Fi router and device ready for installation

The layout of the interface created in the *ThingSpeak* cloud application is presented in Figure 7.4. The numerical value of the battery voltage is displayed and rounded to two decimal places: displaying more than two decimal places is unnecessary. A graph plotting the recorded values is included for analysing patterns and trends. Status indication lights are included to permit swift interpretation of the voltage status of the bus battery. The green light stays on when the voltage is above 23.8 V. When it is equal to or lower than the specified value, the red light is illuminated.

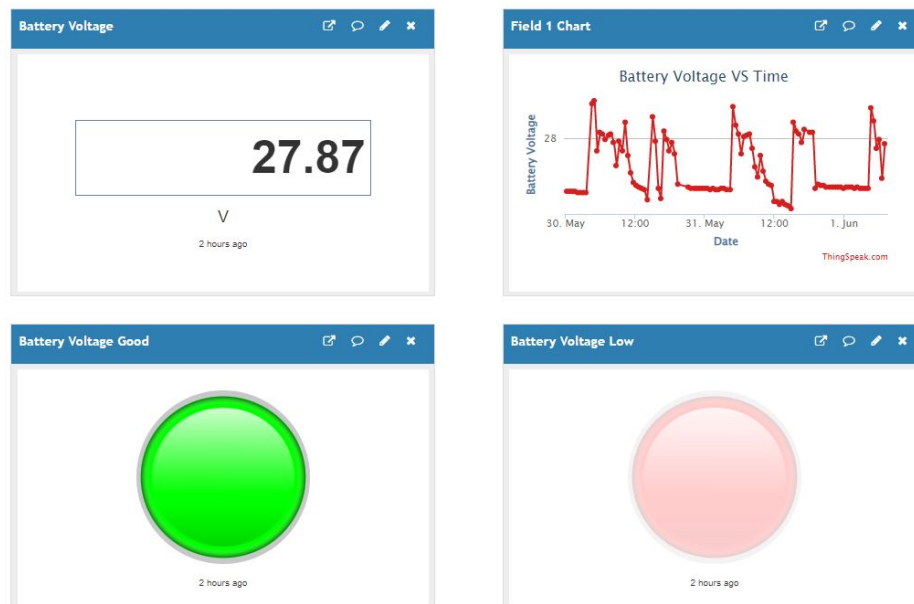

**Figure 7.4:** *ThingSpeak* interface

Data collection took place over a span of four days. Two of those days were weekdays when the bus operated according to its normal schedule and during the other two days, the bus was stationary at a depot over a weekend. The graph in Figure 7.5 shows the data collected during the operational days when the bus completed its shifts. During working hours, the battery voltage fluctuates, with some frequent voltage spikes appearing. The higher voltage readings occur when the bus is accelerating, and the alternator provides a greater power supply to the battery. At lower engine speeds, the voltage trends downward as electrical components draw power. Modern vehicles have a higher demand for electrical power that can lead to charging deficiencies at low engine speeds and during idle conditions (Liang *et al.*, 1999). Inadequate charging of an automotive battery causes the battery to cycle more, leading to reduced battery life (Liang *et al.*, 1999). Linear trends are observed during overnight storage periods.



**Figure 7.5:** Data collected during two operational days

Monitoring the battery voltage over a weekend is visualised in the graph in Figure 7.6. It is likely that the bus was started or moved each morning over the specific weekend, as indicated by the voltage pattern in Figure 7.6. Over longer stationary periods, the battery voltage has a slight downward trend as it slowly discharges. This discharge trend is caused by the tendency of batteries to discharge over time and because some of the electrical systems on the bus might not be completely switched off. Some electrical components on the bus are not connected through the ignition switch, but directly to the battery and can continue

to draw power after the bus is switched off. Outlier voltage spikes are observed each morning in Figures 7.5 and 7.6. The morning voltage spikes are a possible result of power released during surges in the bus's electrical system after start-up. Surges can result from power switching in a system, load changing in a power distribution system, or system faults (Xi *et al.*, 2015). However, power surges only appear for brief periods (Xi *et al.*, 2015). It could also be possible that all the on-board electronic equipment on the bus has not been switched on during these short morning periods, resulting in the battery operating at a higher voltage for those periods.

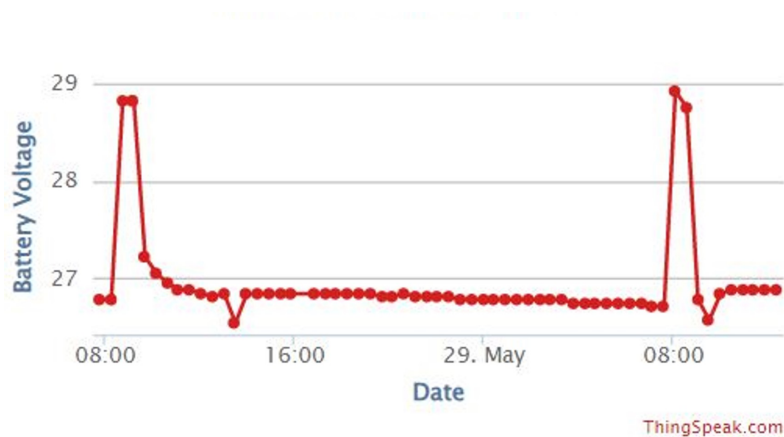

**Figure 7.6:** Battery voltage monitored over weekend

No battery failure was detected during the operational test. More testing time would be required if the demonstrator has to detect a battery failure. This would not be necessary since the demonstrator has proven its capability in the three tests performed. A connected equipment network is successfully established in the sense that the device is installed on an inner city bus, wirelessly transmits data to a cloud platform, and activates maintenance notifications if a problem is detected. The concept demonstrator is proven to be adequate in addressing the key parameter identified for causing downtime at an inner city public bus service. Successful commissioning of the concept demonstrator signifies that the smart maintenance system has applicability in other cases. How the system applies to other cases is elaborated on in the next section. With the case study outcome presented and

discussed, the findings can be used to evaluate the smart maintenance system.

## 7.2 System Evaluation

Evaluation is seen as the process of examining the ability of a system to handle real-world problems in a specific field (O’Leary *et al.*, 1990). Evaluating the system is done by considering the outcome of the case study to determine the degree to which the system requirements defined in Section 5.1 are satisfied, validating the smart maintenance system in the process.

This section, describes to what degree the defined requirements of the smart maintenance system are fulfilled. The degree of fulfilment is determined by the experiment results obtained from the case study. The type of fulfilment is defined by “Yes” or “No” and specified for each requirement in Table 7.3.

Only three requirements were not met because of certain individual reasons. Access to the vehicle’s ECU was not established due to the sensor data from the ECU not being required during the case study. The concept demonstrator was not required to determine the remaining useful life of components due to the nature of the problem it addressed. This system requirement can be tested and incorporated as the system is further developed in the future. Well-established remaining useful life estimation models do exist and can be trained for analysing data from monitored components when necessary. Utilising service records was also not an essential requirement for the concept demonstrator and can be incorporated when more parts are monitored by the system in future installations.

Requirements set out for data collection, processing, and analysis are fulfilled, except for the ones previously specified. The requirements mentioned are met by setting up a demonstrator device that wirelessly transfers data to a cloud platform where it is analysed to check for faults. The data visualisation requirements are met as the *ThingSpeak* interface created shows when an anomaly happens, displays

the system's parameters, and has the historic values ready upon request.

The decision support requirements are met, except the optional one, on the basis that the case study system could generate a maintenance notification that identifies the bus and defines when, where, and what maintenance tasks to perform. Assigning resources and spare parts was not comprehensively required in the case study, by virtue of the fact that the maintenance activity associated with solving that problem is obvious. This requirement is proclaimed to be met, as it is implied through the other decision support functions. Daily health status updates are accessible to the maintenance personnel from the cloud interface.

In the case study, the demonstrator could be installed without the organisation's operating context having an influence on the requirements or functions it is based on. The demonstrator system was commissioned in such a way that it can integrate additional functions if required. On this basis, the demonstrator manifested that the system's requirements for being adaptable to other cases are satisfied. The cost of the concept demonstrator is calculated to be R474.92, confirming that it is indeed a cost-effective solution. The parts list and cost calculation are included in Appendix B.1. The concept demonstrator managed a satisfactory level of security by facilitating a closed network connection and protecting stored data with passwords, thus meeting the security requirements.

All the requirements are met except for one essential and two optional requirements that are included as part of recommendations for further research. From observing Table 7.3, it is established that 21 out of the 24 requirements are fulfilled. This outcome is adequate to verify that the concept demonstrator accomplished the objective of validating the smart maintenance system for inner city bus services developed in Chapter 5. It can be stated that the developed smart maintenance system is a valid solution to support inner city public bus services to improve their maintenance practices.

**Table 7.3:** Smart maintenance system requirements fulfilment

Requirements		Fulfilment	
1	Data collection	Identify key parameters	Yes
		Sensor data collection	Yes
		Vehicle ECU Access	(Optional)
2	Data processing	Wireless data transfer	Yes
		Data transfer in preferred intervals	Yes
3	Data analysis	Detect and identify faults	Yes
		Remaining useful life estimation	Future
		Cloud computing	Yes
4	Data visualisation	GUI	Yes
		Indicate anomaly	Yes
		Display system parameters	Yes
		Accessibility of historic values	Yes
5	Decision support	Identify buses from the fleet	Yes
		Define when and where to perform maintenance	Yes
		Classify what maintenance tasks to perform	Yes
		Assign resources and spare parts	Yes
		Daily health status updates	Yes
		Use service records to narrow down problem	(Optional)
6	Cost-effective	Integrate into existing infrastructure	Yes
		Minimal training required	Yes
7	Adaptable	Support different organisational structures	Yes
		Able to integrate additional functions	Yes
8	Security	Secure network connection	Yes
		Store data safely	Yes



## 7.3 System Refinement

Refinement of the system is discussed in the context of the concept demonstrator's case. The tested system focused on the main problem identified for a certain organisation to conduct a case study for the purpose of validating the system. Refinement of this system should be focused on capability expansion, allowing the system to address more key parameters identified for causing downtime of inner city buses. So far, the system commissioned diagnostic software to detect when a bus battery is discharged. Including prognostic software will increase the range of components the system can monitor. Prognostics will enable the system to predict the health status of parts as well as the estimated remaining useful life.

Additional refinement of the system implemented in the case study can be to include a temperature sensor in the device configuration to monitor the battery temperature. Monitoring the ambient temperature of a battery is relevant as a rise in temperature will accelerate the battery's discharge rate and cause it to drain at a faster pace (Tan and Tiew, 2014). As a result, the ambient temperature of the battery will indicate when necessary action must be taken to bring the temperature down whenever it surpasses a predetermined undesirable level. A current sensor can be added to the system in conjunction with the temperature sensor. To extend battery life, it is necessary to monitor and limit the discharge current from the battery (Tan and Tiew, 2014). As the mean discharge current from the battery increases, the battery's efficiency decreases (Pedram and Wu, 1999).

Data gathered by the system can be used to find correlations between the sensor readings and the degradations of other key components for PHM purposes. In the concept demonstrator's case, the system would be able to use the battery's voltage measurements to determine the condition of the alternator. When an alternator malfunction develops, the voltage and current output of the alternator decrease, which causes the battery to commence discharging (Puzakov, 2020). Furthermore, if the voltage detection frequency is significantly increased, it could be possible to determine the starter motor's condition by analysing the time it takes for the motor to turn over. A function focusing on finding and using data correlations can

be researched and included in the smart maintenance system's architecture and requirements as it is further refined. Both the alternator and starter motor are underlying causes of downtime at the case study organisation and it will be beneficial to use data correlations to monitor these components for their case. Another feature that should be integrated is GPS tracking. This will ensure that the bus can be located quickly and also enable the improved evaluation of the driver KPIs by inspecting driver behaviour patterns online.

The software and hardware used in the case study set-up are for demonstration and validation purposes. For commercial applications, more robust equipment will have to be considered. During daily operation, the equipment on a bus is exposed to high temperatures, high humidity, large amounts of dust, and extreme forces, that can easily destroy electronics. It is recommended that the case study organisation source electronic components that have already proven their long-term reliability in a bus operating environment when constructing an on-board monitoring system for commercial use. This will guarantee that the system can function reliably over long operational periods without rigorous testing. The device tested in the case study operated successfully, as it is configured, and the suggestions for refining it are to encourage continuous improvement.

## 7.4 Chapter Summary

This chapter includes a case study that is used to validate the smart maintenance system. The concept demonstrator is tested by carrying out the planned experiment. The system is evaluated by considering the outcome of the case study and the results are discussed. To conclude this chapter, suggestions are provided for improving the system.

# Chapter 8

## Conclusion and Recommendations

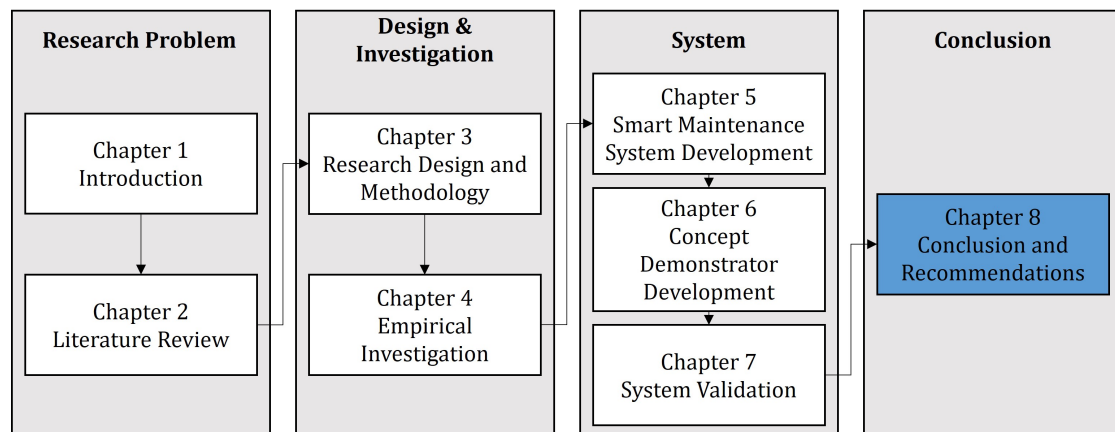

The chapter provides an overview of the research undertaken in this thesis. First, a summary of each chapter is provided by discussing the research approach and content of each. Thereafter, it is discussed how the research questions were approached and answered. The limitations and recommendations for further research conclude the chapter.

### 8.1 Research Summary

This thesis consists of eight chapters and in the following sections, an overview of each chapter is presented to give a summary of this research study.

Chapter 1 introduces this research study and starts with background information on the research topic. The research problem statement and questions are defined. The research objectives are derived from the research questions. An overview of the research methodology and design is provided. Important ethical considerations are discussed. The limitations and delimitations of this research are stated, followed by the contributions. The chapter finishes with the outline of this thesis.

Chapter 2 reviews the literature that is relevant to this thesis. Maintenance and the different existing maintenance strategies are defined and looked into, with a detailed discussion regarding smart maintenance. Industry 4.0 technologies that support smart maintenance are identified and comprehended. An understanding is gained of PHM approaches in maintenance. Studies related to this research are summarised and discussed.

In Chapter 3, the research design and methodology are set out in detail. An outline of the research approach is given, as well as a summary of the study. The chapter concludes with the research techniques utilised in the thesis.

Chapter 4 conducts an empirical investigation to collect supplementary data for this study. Structured interviews are conducted with four interviewees holding maintenance management-type positions at different inner city bus services in Germany and South Africa. Information gathered from the interviews is analysed and presented, followed by a discussion of the interview feedback.

In Chapter 5, the requirements for the smart maintenance system are laid out and defined. Subsequently, the system functions are discussed and configured to establish a complete system. Suitable hardware and software are selected for the development of a concept demonstrator of the smart maintenance system.,

Chapter 6 presents the hardware and software set-up of the concept demonstrator, representing the smart maintenance system. Finally, the experiment is

designed to evaluate the concept demonstrator's functionality, in order to determine the feasibility of the smart maintenance system.

In Chapter 7, validation of the smart maintenance system is performed by conducting a case study. Performing the designed experiment is done to test the concept demonstrator. The results are discussed, and the system is assessed based on the findings from the case study. To complete the chapter, suggestions are made for refining the system.

Chapter 8 gives an overview of the research conducted. Key findings from the research are summarised and conclusions are drawn. The chapter ends by stating the limitations and recommendations for further research.

## 8.2 Research Contributions and Conclusions

The research contributions and conclusions drawn from the research conducted are organised in accordance with the research questions defined in Chapter 1. The SRQs answers are provided first, followed by the PRQ answer.

*SRQ 1: What Industry 4.0 and smart maintenance systems are available to improve maintenance of inner city buses?*

Conducting a comprehensive literature review identified the relevant Industry 4.0 technologies that support smart maintenance. The technologies are Big Data and analytics, the Internet of Things, cloud computing, cyber-physical systems, and artificial intelligence. These technologies propel the digitalisation of maintenance strategies and practices. The requirements and outline are established for a smart maintenance system from theory in the relevant literature. Lucke *et al.* (2017, p. 83) constructed the architecture of a future maintenance planning system from the defined requirements for a smart maintenance system. This architecture forms the foundation for the smart maintenance system developed in this research

study for inner city public bus services.

The literature review investigated existing smart maintenance approaches for transportation systems. Four related research studies are summarised and discussed in the literature review to gain insight into what has been done in this field in the industry up to now. The related studies made it evident that as yet no comprehensive smart maintenance system exists for inner city public bus services. From the related studies, two architectures were identified that are approaching something such as a smart maintenance system. The architectures are: Predictive maintenance fleet management system architecture from Killeen *et al.* (2019, p. 609) and architecture of the data acquisition on-board system from Massaro *et al.* (2020, p. 182). These architectures contain some of the characteristics of a smart maintenance system, but they cannot explicitly be identified as one. Some attributes from these architectures are used in the system design.

*SRQ 2: What are the operational parameters and systems of inner city buses which affect reliability?*

An empirical investigation researched the factors influencing the reliability degradation of inner city buses, identifying what components are responsible for the most downtime, and considered how the unit life of the identified components can be improved. The investigation was conducted through the use of structured interviews held with two inner city public bus organisations situated in Germany and two in South Africa. It was found that the operating context of an organisation is one of the most influential factors in the maintenance strategy and implementation method of a specific organisation. Each organisation proved to have their own key factors causing downtime of their inner city buses, resulting from the difference in operating context. Designing a completely generic system was found to not be feasible and to overcome this, an initial problem identification step is included in the designed smart maintenance system to allow the rest of the system to be generalised.

*SRQ 3: How can the functionality of the developed smart maintenance system*

*for inner city bus services be validated?*

Validation of the developed smart maintenance system is performed by conducting a case study with an industry partner. To conduct the case study, a concept demonstrator was designed that addresses the key component resulting in the most downtime of inner city buses at a specific organisation. Configuration of the concept demonstrator system is based on the smart maintenance system requirements and architecture defined in the research. By successfully commissioning and testing the demonstrator system, the case study organisation is equipped with a system that improves their maintenance strategy regarding their key parameter causing downtime.

Using the case study results, the smart maintenance system is validated by determining the degree to which the defined requirements are fulfilled. The smart maintenance system requirements are fulfilled to a satisfactory level to show that the developed system is a valid solution to improve the maintenance strategy and practices of inner city public bus services.

***PRQ:*** *How can a smart maintenance system be developed for inner city public bus services through related Industry 4.0 technologies?*

The proposed answer to the PRQ incorporates the results of the SRQs. A smart maintenance system for inner city public bus services is developed, aligned with the scope of the thesis. Designing the system is accomplished by combining the relevant literature and feedback on what is required in the industry. More specifically, the complete system results from reflecting on the detailed literature review and thorough empirical investigation, whilst promoting digitalisation through utilising the latest Industry 4.0 technologies that support smart maintenance. It is determined that Industry 4.0 technologies are implemented at a very low maturity level at inner city public bus services. Employing the Industry 4.0 technologies supporting smart maintenance, can improve the effectiveness and efficiency of the maintenance practices at these organisations.

The requirements for the smart maintenance system are defined and the architecture of its functionalities is laid out. All the requirements strive to minimise the downtime of inner city buses. Data is the primary subject in the first parts of the requirements that consist of data collection, data processing, data analysis, and data visualisation. These are followed by requirements for supporting decision-making. Being cost-effective is another part of the requirements as well as adaptability. Ensuring security is the final part of the requirements, that stipulates network connections must be secure and data must be stored safely.

The smart maintenance system architecture shows how the system functions are positioned and where the different layers interact. Three layers make up the architecture, with the first layer consisting of condition monitoring features, the middle layer contains IoT characteristics, and the application layer consists of functions aligned to support data-driven decision-making with regard to smart maintenance planning. Validating the functionality of the developed smart maintenance system is performed as a case study in the industry. Maintenance managers at inner city public bus services can use the smart maintenance system to improve their maintenance strategy and practices by implementing the system that adheres to the defined requirements and architecture.

### 8.3 Limitations

It is important to discuss the limitations of this research. The study concentrated on how inner city public bus services can more effectively maintain their bus fleets through the deployment of a smart maintenance system to improve their maintenance practices and processes. Industry 4.0 technologies that relate to smart maintenance are identified and used to configure the system.

In the course of the research, four interviews were conducted on an online basis, with interviewees representing their respective organisations. The interviewees' expertise levels varied to some degree and, in the final interview, the interviewees could not answer some of the set questions. During the validation phase, the sys-



tem was only partially implemented at an inner city public bus service to test the effectiveness and generalisation of the system. Due to ongoing operations and the challenge of implementing a new approach to maintenance on their entire fleet, the system was only partially deployed at the industry partner. In order to address the limitations, recommendations for future research are made in the following section.

## 8.4 Further Research Recommendations

To expand on the contributions made during this research, the following recommendations for future research are presented:

1. An in-depth literature review identified the Industry 4.0 technologies that support smart maintenance. For further research, technologies that can be associated with Industry 5.0 should be researched and considered, ensuring the future applicability of the developed system. Systems are continuously developing (Fogel and Lyra, 1997), because they are constantly evolving and transforming (Kelso, 1995).
2. An existing opportunity is to collect more data by conducting a broader empirical investigation. Two organisations were interviewed in Germany and two in South Africa. It was found that the organisations have a substantial difference in operating context between them that results in them identifying diverse causes of downtime of the buses. Interviews can be conducted with more organisations in each country as well as from other countries to increase the geographical diversity. Performing more interviews will provide a better understanding of how and why these organisations have different maintenance problems and strategies. Consequently, more data will be available for interpreting results and drawing conclusions of how the smart maintenance system can assist inner city public bus services.
3. One essential and two optional requirements of the smart maintenance system were not fulfilled by the outcome of the case study. The two optional

requirements state that vehicle ECU access should be established and service records should be utilised to narrow down maintenance issues detected. The essential requirement concerns remaining useful life estimations. The concept demonstrator system illustrated all except one of the principal functions of the system. It did not need the mentioned requirements due to the nature of the key component it addressed. More sophisticated diagnostic and prognostic capabilities, including remaining useful life estimations and higher-level decision support functionalities, can be added to the demonstrator system as it continues to be developed in the future. For further research, it is recommended to design a concept demonstrator that monitors key components resulting in downtime that will require the previously mentioned requirements to be employed.

4. A recommendation for further validation is to perform case studies on a larger scale by expanding the test cases to greater or entire fleets. More data can be collected on the performance of the system over longer terms. Testing the system on larger scales and over longer periods will showcase if the system can maintain longevity while operating reliably in real-world scenarios.

In essence, the further research recommendations present additional opportunities to broaden and enhance the research in this field.

## 8.5 Chapter Summary

The research undertaken in this thesis is summarised in this chapter. An overview of each chapter is provided, which includes a discussion of each chapter's research approach and content. The method for approaching and answering the research questions is outlined. The chapter concludes with a discussion of the limitations of the study, and suggestions for future research.

## List of References

Adams, S., Malinowski, M., Heddy, G., Choo, B. and Beling, P.A. (2017). The wear methodology for prognostics and health management implementation in manufacturing. *Journal of Manufacturing Systems*, vol. 45, pp. 82–96.

Available at: <https://www-sciencedirect-com.ez.sun.ac.za/science/article/pii/S0278612517301048>

Alam, T. (2020 January). Cloud computing and its role in the information technology. *SSRN Electronic Journal*.

Available at: [https://www.researchgate.net/publication/343176042\\_Cloud\\_Computing\\_and\\_Its\\_Role\\_in\\_the\\_Information\\_Technology/citation/download](https://www.researchgate.net/publication/343176042_Cloud_Computing_and_Its_Role_in_the_Information_Technology/citation/download)

Amaral, A., Baretto, L. and Pereira, T. (2017). Industry 4.0 implications in logistics: an overview.

Available at: <https://www.sciencedirect.com/science/article/pii/S2351978917306807>

Amarasinghe, M., Kottegoda, S., Arachchi, A.L., Muramudalige, S., Bandara, H.M.N.D. and Azeez, A. (2015). Cloud-based driver monitoring and vehicle diagnostic with obd2 telematics. *International Journal of Handheld Computing Research*, vol. 6.

Available at: [https://www.researchgate.net/publication/280884222\\_Cloud-Based\\_Driver\\_Monitoring\\_and\\_Vehicle\\_Diagnostic\\_with\\_OBD2\\_Telematics](https://www.researchgate.net/publication/280884222_Cloud-Based_Driver_Monitoring_and_Vehicle_Diagnostic_with_OBD2_Telematics)

Ammar, M., Janjua, H., Thangarajan, A., Crispo, B. and Hughes, D. (2020). Securing the on board diagnostics port obd ii in vehicles. *SAE Int. J. Transp. Cyber. and Privacy*, vol. 2, pp. 83–106.

Available at: <https://saemobilus-sae-org.ez.sun.ac.za/content/11-02-02-0009/>

- Antony, J. (2003). *Design of Experiments for Engineers and Scientists*. Butterworth-Heinemann, Oxford.  
Available at: <https://www.sciencedirect.com/science/article/pii/B9780750647090500004>
- Atlam, H., Walter, R. and Wills, G. (2018 September). Internet of things: State of the art, challenges, applications, and open issues. *International Journal of Intelligent Computing Research*, vol. 9, pp. 928–938.  
Available at: [https://www.researchgate.net/publication/327845273\\_Internet\\_of\\_Things\\_State-of-the-art\\_Challenges\\_Applications\\_and\\_Open\\_Issues](https://www.researchgate.net/publication/327845273_Internet_of_Things_State-of-the-art_Challenges_Applications_and_Open_Issues)
- Ayab, S., Terissa, L.S. and Zerhouni, N. (2018). An iot approach for a smart maintenance.  
Available at: [https://www.researchgate.net/publication/324091447\\_An\\_IoT\\_approach\\_for\\_a\\_smart\\_maintenance](https://www.researchgate.net/publication/324091447_An_IoT_approach_for_a_smart_maintenance)
- Bailey, C., Sutharssan, T., Yin, C. and Stoyanov, S. (2015). Prognostic and health management for engineering systems: a review of the data driven approach and algorithms. *The Journal of Engineering*.  
Available at: [https://www.researchgate.net/publication/281761527\\_Prognostic\\_and\\_health\\_management\\_for\\_engineering\\_systems\\_a\\_review\\_of\\_the\\_data-driven\\_approach\\_and\\_algorithms](https://www.researchgate.net/publication/281761527_Prognostic_and_health_management_for_engineering_systems_a_review_of_the_data-driven_approach_and_algorithms)
- Beker, I., Kesic, I., Radlovacki, V., Delic, M., Sevic, D. and Moraca, S. (2017). Improvement of the maintenance management process of complex technical systems which demand high reliability.  
Available at: [https://www.researchgate.net/publication/328686120\\_Improvement\\_of\\_the\\_maintenance\\_management\\_process\\_of\\_complex\\_technical\\_systems\\_which\\_demand\\_high\\_reliability](https://www.researchgate.net/publication/328686120_Improvement_of_the_maintenance_management_process_of_complex_technical_systems_which_demand_high_reliability)
- Bekesi, J., Brodник, A., Kresz, M. and Pash, D. (2009). *Logistik Management*, chap. An Integrated Framework for Bus Logistics Management: Case Studies, pp. 389–411.  
Available at: [https://www.researchgate.net/publication/225945037\\_An\\_Integrated\\_Framework\\_for\\_Bus\\_Logistics\\_Management\\_Case\\_Studies](https://www.researchgate.net/publication/225945037_An_Integrated_Framework_for_Bus_Logistics_Management_Case_Studies)
- Bivona, E. and Montemaggiore, G.B. (2010). Understanding short and long term implications of myopic fleet maintenance policies: a system dynamics application to a city bus company. *System Dynamics Review*, vol. 26, no. 3, pp. 195–215.

- Available at: <https://onlinelibrary-wiley-com.ez.sun.ac.za/doi/abs/10.1002/sdr.450>
- Bokrantz, J., Skoogh, A., Berlin, C., Wuest, T. and Stahre, J. (2019). Smart maintenance: an empirically grounded conceptualization.  
Available at: <https://www.sciencedirect.com/science/article/pii/S0925527319303615>
- Bokrantz, J., Skoogh, A., Cecilia, B. and Stahre, J. (2020). Smart maintenance: instrumentdevelopment, content validationand an empirical pilot.  
Available at: <https://www-emerald-com.ez.sun.ac.za/insight/content/doi/10.1108/JMTM-06-2020-0222/full/html>
- Bonomi, F., Milito, R., Natarajan, P. and Zhu, J. (2014). Fog computing: A platform for internetof things and analytics. In: *Big Data and Internet of Things*.  
Available at: <https://www.semanticscholar.org/paper/Fog-Computing:-A-Platform-for-Internet-of-Things-Bonomi-Milito/29b5bf27ac523a36f9c39260c0a3728542b7a850>
- Borro, D., Suescun, A., Brazalez, A., Gonzalez, M.J., Ortega, E. and Gonzalez, E. (2021). Warm: Wearable ar and tablet based assistant systems for bus maintenance. *Applied Sciences*, vol. 11, no. 4.  
Available at: <https://www.mdpi.com/2076-3417/11/4/1443>
- Bryman, A. and Bell, E. (2011). *Business Research Methods*. 3rd edn. Oxford University Press Inc., New York.  
Available at: [https://www.uwcentre.ac.cn/haut/wp-content/uploads/2018/11/Alan\\_Bryman\\_Emma\\_Bell\\_Business\\_Research\\_Methodsb-ok.cc.pdf](https://www.uwcentre.ac.cn/haut/wp-content/uploads/2018/11/Alan_Bryman_Emma_Bell_Business_Research_Methodsb-ok.cc.pdf)
- Budakoti, J. (2018). *An IoT Gateway Middleware for interoperability in SDN Managed Internet of Things*. Ph.D. thesis, Carleton University.  
Available at: <https://curve.carleton.ca/98830d8a-ac2e-4fd9-a095-8ffd82f160fd>
- Bughin, J., Hazan, E., Ramaswamy, S., Chui, M., Allas, T., Dahlstrom, P., Henke, N. and Trench, M. (2017). How artificial intelligence can deliver real value to companies. *McKinsey Global Institute*, pp. 1–80.  
Available at: <https://www.mckinsey.com/business-functions/mckinsey->

- analytics/our-insights/how-artificial-intelligence-can-deliver-real-value-to-companies#
- Byington, C.S., Roemer, M.J. and Galie, T. (2002). Prognostic enhancements to diagnostic systems for improved condition-based maintenance.  
Available at: [https://www.researchgate.net/publication/3968788\\_Prognostic\\_enhancements\\_to\\_diagnostic\\_systems\\_for\\_improved\\_condition-based\\_maintenance](https://www.researchgate.net/publication/3968788_Prognostic_enhancements_to_diagnostic_systems_for_improved_condition-based_maintenance)
- Byttner, S., Nowaczyk, S., Prytz, R. and Rognvaldsson, T. (2013). A field test with self-organized modeling for knowledge discovery in a fleet of city buses. *IEEE International conference on Mechatronics and Automation*.  
Available at: [https://www.researchgate.net/publication/256486887\\_A\\_field\\_test\\_with\\_self-organized\\_modeling\\_for\\_knowledge\\_discovery\\_in\\_a\\_fleet\\_of\\_city\\_buses](https://www.researchgate.net/publication/256486887_A_field_test_with_self-organized_modeling_for_knowledge_discovery_in_a_fleet_of_city_buses)
- Cao, S., Chan, K. and Elkamel, A. (2019). A controlled experiment investigating the effects of explanatory manual on adherence to operating procedures. *Safety*, vol. 5, no. 2.  
Available at: <https://www.mdpi.com/2313-576X/5/2/19>
- Chandola, V., Banerjee, A. and Kumar, V. (2009 July). Anomaly detection: A survey. *ACM Comput. Surv.*, vol. 41.  
Available at: [https://www.researchgate.net/publication/220565847\\_Anomaly\\_Detection\\_A\\_Survey/citation/download](https://www.researchgate.net/publication/220565847_Anomaly_Detection_A_Survey/citation/download)
- Cherryholmes, C. (1992). Notes on pragmatism and scientific realism. *Educational Researcher*, vol. 21, no. 6, pp. 13–17.
- Creswell, J. (2009). *Research design qualitative, quantitative, and mixed methods approaches*. 3rd edn. SAGE Publications, Thousand Oaks, California.
- Creswell, J.W. and Creswell, J.D. (2018). *Research design. Qualitative, quantitative, and mixed methods approaches*. 5th edn. Los Angeles: SAGE.
- Dastjerdi, A., Gupta, H., Calheiros, R., Ghosh, S. and Buyya, R. (2016 December). *Fog Computing: Principles, Architectures, and Applications*, pp. 61–75.  
Available at: [https://www.researchgate.net/publication/304108757\\_Fog\\_Computing\\_Principals\\_Architectures\\_and\\_Applications](https://www.researchgate.net/publication/304108757_Fog_Computing_Principals_Architectures_and_Applications)

- Datta, S.K., Bonnet, C. and Nikaiein, N. (2014). An iot gateway centric architecture to provide novel m2m services. *2014 IEEE World Forum on Internet of Things*, pp. 514–519.  
Available at: [https://www.researchgate.net/publication/269309181\\_An\\_IoT\\_gateway\\_centric\\_architecture\\_to\\_provide\\_novel\\_M2M\\_services](https://www.researchgate.net/publication/269309181_An_IoT_gateway_centric_architecture_to_provide_novel_M2M_services)
- Davis, R.I., Burns, A., Bril, R.J. and Lukkien, J.J. (2007). Controller area network (can) schedulability analysis: Refuted, revisited and revised. *Real-Time Systems*, pp. 239–272.  
Available at: <https://link-springer-com.ez.sun.ac.za/article/10.1007/s11241-007-9012-7#citeas>
- de Jonge, B., Teunter, R. and Tinga, T. (2017). The influence of practical factors on the benefits of condition-based maintenance over time-based maintenance. *Reliability Engineering and System Safety*, vol. 158, pp. 21–30.  
Available at: <https://www-sciencedirect-com.ez.sun.ac.za/science/article/pii/S0951832016306238>
- Dhall, R. and Solanki, V. (2017). An iot based predictive connected car maintenance approach. *International journal of interactive multimedia and artificial intelligence*, vol. 4, no. 3, pp. 16–22.  
Available at: [https://www.ijimai.org/journal/sites/default/files/files/2016/08/ijimai20174\\_3\\_3\\_pdf\\_12469.pdf](https://www.ijimai.org/journal/sites/default/files/files/2016/08/ijimai20174_3_3_pdf_12469.pdf)
- DIN31051 (2019 June). Grundlagen der instandhaltung. Berlin, Germany: Beuth Verlag.
- DINEN13306 (2018 February). Instandhaltung - begriffe der instandhaltung. Berlin, Germany: Beuth Verlag.
- Dobbin, S. and Gatowski, S. (1999). *A judges deskbook on the basic philosophies and-methods of science*. Master's thesis, University of Nevada, Reno.  
Available at: [https://www.researchgate.net/publication/318100549\\_A\\_Judge's\\_Deskbook\\_on\\_the\\_Basic\\_Philosophies\\_and\\_Methods\\_of\\_Science](https://www.researchgate.net/publication/318100549_A_Judge's_Deskbook_on_the_Basic_Philosophies_and_Methods_of_Science)
- Doody, O. and Noonan, M. (2013). Preparing and conducting interviews to collect data. *Nurse researcher*, vol. 20, no. 5.  
Available at: [https://ulir.ul.ie/bitstream/handle/10344/5588/Doody\\_2013\\_preparing.pdf?seq](https://ulir.ul.ie/bitstream/handle/10344/5588/Doody_2013_preparing.pdf?seq)

- Dumez, H. (2015 July). What is a case, and what is a case study? *Bulletin of Sociological Methodology/Bulletin de Methodologie Sociologique*, vol. 127, no. 1, pp. 43–57.  
Available at: <https://journals.sagepub.com/doi/abs/10.1177/0759106315582200?journalCode=bmsa>
- Ermonts-Holley, R. (2016). Digitaler schatten, zustandsprognose und hochfrequenzsynchronisation industrieorientierte forschung zu smart maintenance.  
Available at: [https://www.easyfairs.com/fileadmin/groups/9/maintenance/Stuttgart\\_2016/Dokumente/ScienceCenter\\_2016/Roman\\_Emonts-Holley\\_20160428\\_FIR\\_Vortrag\\_Stuttgart\\_final.pdf](https://www.easyfairs.com/fileadmin/groups/9/maintenance/Stuttgart_2016/Dokumente/ScienceCenter_2016/Roman_Emonts-Holley_20160428_FIR_Vortrag_Stuttgart_final.pdf)
- Escabi, M. (2012). *Introduction to Biomedical Engineering (Third Edition)*, chap. Chapter 11 - Biosignal Processing, pp. 667–746. 3rd edn. Academic Press, Boston.  
Available at: <https://www.sciencedirect.com/science/article/pii/B9780123749796000113>
- Espressif (2020). Esp8266ex datasheet.  
Available at: [https://www.espressif.com/sites/default/files/documentation/0a-esp8266ex\\_datasheet\\_en.pdf](https://www.espressif.com/sites/default/files/documentation/0a-esp8266ex_datasheet_en.pdf)
- Fan, Y.J., Yin, Y.H., Xu, L.D., Zeng, Y. and Wu, F. (2014). Iot-based smart rehabilitation system. *IEEE transactions on industrial informatics*, vol. 10, no. 2, pp. 1568–1577.  
Available at: <https://ieeexplore-ieee-org.ez.sun.ac.za/document/6722995>
- Fogel, A. and Lyra, M.C.D.P. (1997). Dynamics of development in relationships. *The Psychological Meaning of Chaos: Translating theory into practice*, pp. 75–76.  
Available at: <https://psycnet.apa.org/record/1997-09042-003>
- Fransiska, R.W., Septia, E.M.P., Vessabhu, W.K., Frans, W., Abednego, W. and Hendro (2013). Electric power measurements using arduino uno microcontroller and labview. *2013 3rd International Conference on Instrumentation, Communications, Information Technology and Biomedical Engineering (ICICI-BME)*, pp. 226–229.  
Available at: <https://ieeexplore.ieee.org/abstract/document/6698497>
- Galar, D., Farinha, J., Ferreira, L. and Raposo, H. (2017). Dimensioning reserve bus fleet using life cycle costmodels and condition based/predictive maintenance:a case study.  
Available at: <https://link.springer.com/article/10.1007/s12469-017-0167-x>



- Gandomi, A. and Haider, M. (2015 April). Beyond the hype: Big data concepts, methods, and analytics. *International Journal of Information Management*, vol. 35, no. 2, pp. 137–144.  
Available at: <https://www.sciencedirect.com/science/article/pii/S0268401214001066>
- Garg (2006). Maintenance management: literature review and directions. *Journal of Quality in Maintenance Engineering*, vol. 12, no. 3, pp. 205–238.  
Available at: <https://www.proquest.com/docview/215551651?parentSessionId=yMmLsgr0ev+sku00fcuuyCGXD88rxhWwfhce9ewy7bw=&pq-origsite=primo&accountid=14049>
- Gerring, J. (2004). What is a case study and what is it good for? *The American Political Science Review*, vol. 98, no. 2, pp. 341–354.  
Available at: <https://www.proquest.com/docview/214412110?parentSessionId=a6fhoxLuY4e7iZA+7kSpdkdmTN3IQZblbHi8RsvVE20=&pq-origsite=primo&accountid=14049>
- getbybus (2021). Bus munich. Online.  
Available at: <https://getbybus.com/en/blog/bus-munich/>
- Graff, J.C. (2017). *Evidence based practice An integrative approach to research, administration, and practice*, chap. Mixed methods research, pp. 47–66. 2nd edn. Burlington, MA, Jones and Bartlett.
- Haghani, A. and Shafahi, Y. (2001 June). Bus maintenance systems and maintenance scheduling model formulations and solutions. *Transportation Research Part A: Policy and Practice*, vol. 36, no. 5, pp. 453–482.  
Available at: <https://www-sciencedirect-com.ez.sun.ac.za/science/article/pii/S0965856401000143>
- Harary, F. and Batell, M.F. (1981). What is a system? *Social Networks*, vol. 3, no. 1, pp. 29–40.  
Available at: <https://www.sciencedirect.com/science/article/pii/0378873381900034>
- Hasan, N.N., Arif, A., Pervez, U., Hassam, M. and Husnain, S.S. (2011). Micro controller based on board diagnostic (obd) system for non obd vehicles. *2011 UkSim 13th*

- International Conference on Computer Modelling and Simulation*, pp. 540–544.  
Available at: <https://ieeexplore-ieee-org.ez.sun.ac.za/document/5754278>
- Henke, M., Heller, T. and Stich, V. (2019). Smart maintenance - der weg vom status quo zur zielvision.  
Available at: [https://www.acatech.de/wp-content/uploads/2019/09/acatech\\_STUDIE\\_Smart\\_Maintenance\\_final.pdf](https://www.acatech.de/wp-content/uploads/2019/09/acatech_STUDIE_Smart_Maintenance_final.pdf)
- Hussain, S., Mahmud, U. and Yang, S. (2020). An iot-enabled cloud-assisted smart fleet maintenance system.  
Available at: <https://ieeexplore.ieee.org/document/9060939>
- Ibarra-Rojas, .J., Delgado, F., Giesen, R. and Munoz, J.C. (2015). Planning operation and control of bus transport.  
Available at: <https://www-sciencedirect-com.ez.sun.ac.za/science/article/pii/S0191261515000454>
- Jabareen, Y. (2009 December). Building a conceptual framework philosophy, definitions, and procedure. *International Journal of Qualitative Methods*, pp. 49–62.  
Available at: <https://journals.sagepub.com/doi/10.1177/160940690900800406>
- Jantunen, E., Gorostegui, U., Zurutuza, U., Albano, M., Ferreira, L.L., Hegedus, C. and Campos, J. (2018). Remote maintenance support with the aid of cyber physical systems and cloud technology. *Part I: Journal of Systems and Control Engineering*, vol. 232, no. 6, pp. 784–794.  
Available at: <https://journals-sagepub-com.ez.sun.ac.za/doi/full/10.1177/0959651818772939>
- Jardine, A.K.A., Lin, D. and Banjevic, D. (2006). A review on machinery diagnostics and prognostics implementing condition-based maintenance. *Mechanical Systems and Signal Processing*, vol. 20, pp. 1483–1510.  
Available at: <https://www-sciencedirect-com.ez.sun.ac.za/science/article/pii/S0888327005001512>
- Jasiulewicz-Kaczmarek, M. and Gola, A. (2019). Maintenance 4.0 technologies for sustainable manufacturing: an overview. *IFAC-PapersOnLine*, vol. 52, no. 10, pp. 91–96.  
Available at: <https://www.sciencedirect.com/science/article/pii/S2405896319308468>

- Jimenez, J., Schwartz, S., Vingerhoeds, R. and Grabot, B. (2020). Towards multi-model approaches to predictive maintenance: A systematic literature survey on diagnostics and prognostics. *Journal of Manufacturing Systems*, vol. 56, pp. 539–557.  
Available at: <https://www-sciencedirect-com.ez.sun.ac.za/science/article/pii/S0278612520301187>
- Kaczalski, P. and Slaski, G. (2018). Simulation of operating loads of a city bus powertrain. *IOP Conference Series: Materials Science and Engineering*, vol. 421, no. 2.  
Available at: <https://iopscience-iop-org.ez.sun.ac.za/article/10.1088/1757-899X/421/2/022034>
- Kamaludin, N. and Mulyanti, B. (2020). Cyber physical system in the industry. *IOP Conference Series: Materials Science and Engineering*, vol. 830, no. 3.  
Available at: <https://iopscience-iop-org.ez.sun.ac.za/article/10.1088/1757-899X/830/3/032062>
- Karim, R., Westerberg, J., Galar, D. and Kumar, U. (2016). Maintenance analytics: The new know in maintenance. *IFAC-PapersOnLine*, vol. 49, no. 28, pp. 214–219.  
Available at: <https://www.sciencedirect.com/science/article/pii/S2405896316324612>
- Kelso, J.A.S. (1995). *Dynamic Patterns: The Self Organization of Brain and Behavior*. The MIT Press.
- Killeen, P. (2020). Knowledge-based predictive maintenance for fleet management.  
Available at: <https://ruor.uottawa.ca/handle/10393/40086>
- Killeen, P., Ding, B., Kiringa, I. and Yeap, T. (2019). Iot-based predictive maintenance for fleet management. *Procedia Computer Science*, vol. 151, pp. 607–613.  
Available at: <https://www.sciencedirect.com/science/article/pii/S1877050919306519>
- Kinz, A. and Biedermann, H. (2016). Ein modell zur strategiewahl. *Instandhaltung*, pp. 30–31.  
Available at: <https://www.instandhaltung.de/markt-und-management/forschungsentwicklung/ein-modell-zur-strategiewahl-182.html>

- Kumar, U., Galar, D., Parida, A., Stenstrom, C. and Berges, L. (2013). Maintenance performance metrics: a state of the art review. *Journal of Quality in Maintenance Engineering*, vol. 19, no. 3, pp. 233–277.  
Available at: <https://doi.org/10.1108/JQME-05-2013-0029>
- Labrinidis, A. and Jagadish, H.V. (2012 August). Challenges and opportunities with big data. *Proceedings of the VLDB Endowment*, vol. 5, no. 12, pp. 2032–2033.  
Available at: <https://dl-acm-org.ez.sun.ac.za/doi/abs/10.14778/2367502.2367572>
- Lai, C.D., Murthy, D. and Xie, M. (2006 February). Weibull distributions and their applications. *Springer Handbook of Engineering Statistics*, pp. 63–78.  
Available at: [https://www.researchgate.net/publication/37628953\\_Weibull\\_Distributions\\_and\\_Their\\_Applications/citation/download](https://www.researchgate.net/publication/37628953_Weibull_Distributions_and_Their_Applications/citation/download)
- Lee, J., Bagheri, B. and Kao, H. (2014 December). A cyber physical systems architecture for industry 4.0 based manufacturing systems. *SME Manufacturing Letters*, vol. 3.  
Available at: [https://www.researchgate.net/publication/269709304\\_A\\_Cyber-Physical\\_Systems\\_architecture\\_for\\_Industry\\_40-based\\_manufacturing\\_systems](https://www.researchgate.net/publication/269709304_A_Cyber-Physical_Systems_architecture_for_Industry_40-based_manufacturing_systems)
- Li, R., Verhagen, W. and Curran, R. (2018). A comparative study of data driven prognostic approaches: Stochastic and statistical models. *2018 IEEE International Conference on Prognostics and Health Management*, pp. 1–8.  
Available at: [https://www.researchgate.net/publication/327323888\\_A\\_comparative\\_study\\_of\\_Data-driven\\_Prognostic\\_Approaches\\_Stochastic\\_and\\_Statistical\\_Models/citation/download](https://www.researchgate.net/publication/327323888_A_comparative_study_of_Data-driven_Prognostic_Approaches_Stochastic_and_Statistical_Models/citation/download)
- Li, R., Verhagen, W.J.C. and Curran, R. (2020 January). Stakeholder oriented systematic design methodology for prognostic and health management system: Stakeholder expectation definition. *Advanced Engineering Informatics*, vol. 43.  
Available at: <https://www-sciencedirect-com.ez.sun.ac.za/science/article/pii/S1474034620300100>
- Liang, F., Miller, J.M. and Xu, X. (1999). A vehicle electric power generation system with improved output power and efficiency. *IEEE Transactions on Industry Applications*, vol. 35, no. 6, pp. 1341–1346.

- Available at: <https://ieeexplore.ieee.org/stamp/stamp.jsp?tp=&arnumber=806048>
- Liu, Y., Yu, W., Dillon, T.S., Rahayu, W. and Li, M. (2021). Empowering iot predictive maintenance solutions with ai: A distributed system for manufacturing plant-wide monitoring. *IEEE Transactions on Industrial Informatics*.  
Available at: <https://ieeexplore-ieee-org.ez.sun.ac.za/document/9463585>
- Lokithor (2021 August). How much voltage does a car battery need to start? *JUMP STARTER LOKITHOR*.  
Available at: <https://www.lokithorshop.com/blogs/news/how-much-voltage-car-battery-need-to-start>
- Lucke, D., Defranceski, M. and Adolf, T. (2017). *Handbuch Industrie 4.0 Vol. 1*, chap. Cyberphysische Systeme fur die pradiktiveInstandhaltung, pp. 75–91. Springer Berlin Heidelberg.  
Available at: [https://www.researchgate.net/publication/311506921\\_Cyberphysische\\_Systeme\\_fur\\_die\\_pradiktive\\_Instandhaltung](https://www.researchgate.net/publication/311506921_Cyberphysische_Systeme_fur_die_pradiktive_Instandhaltung)
- Malekian, R., Moloisane, N.R., Nair, L., Maharaj, B.T. and Chude Okonkwo, U.A.K. (2017). Design and implementation of a wireless obd ii fleet management system. *IEEE Sensors Journal*, vol. 17, no. 4, pp. 1154–1164.  
Available at: <https://ieeexplore-ieee-org.ez.sun.ac.za/document/7755775>
- Marr, B. (2018). What is industry 4.0? here’s a super easy explanation for anyone.  
Available at: <https://www.forbes.com/sites/bernardmarr/2018/09/02/what-is-industry-4-0-heres-a-super-easy-explanation-for-anyone/?sh=40d1ee069788>
- Martin, A.J. and Finnegan, M. (2020 September). What is ifttt? how to use if this, then that services.  
Available at: <https://www.computerworld.com/article/3239304/what-is-ifttt-how-to-use-if-this-then-that-services.html>
- Martins, R., Fernandes, F., Infante, V. and Andrade, A. (2021). Simultaneous scheduling of maintenance crew and maintenance tasks in bus operating companies: a case study. *Journal of Quality in Maintenance*.  
Available at: <https://www.emerald.com/insight/publication/issn/1355-2511>

- Massaro, A., Selicato, S. and Galiano, A. (2020). Predictive maintenance of bus fleet by intelligent smart electronic board implementing artificial intelligence. *IoT*, vol. 2, pp. 180–197.  
Available at: [https://www.researchgate.net/publication/344512873\\_Predictive\\_Maintenance\\_of\\_Bus\\_Fleet\\_by\\_Intelligent\\_Smart\\_Electronic\\_Board\\_Implementing\\_Artificial\\_Intelligence](https://www.researchgate.net/publication/344512873_Predictive_Maintenance_of_Bus_Fleet_by_Intelligent_Smart_Electronic_Board_Implementing_Artificial_Intelligence)
- Matyas, K. (2002). Ganzheitliche optimierung durch individuelle instandhaltungsstrategien. *Industrie Management*, vol. 18, pp. 13–16.  
Available at: [http://www.imme2000.de/dokumente/FachspezifischerTeil/Technik/Foerdertechnik/Insthaltungsstrategien\\_e.pdf](http://www.imme2000.de/dokumente/FachspezifischerTeil/Technik/Foerdertechnik/Insthaltungsstrategien_e.pdf)
- Matyas, K. (2016). Instandhaltungslogistik. qualitat und produktivitat steigern. Munchen: Hanser.
- Matyas, K., Meneth, T., Kovacs, K. and Glawar, R. (2017 April). A procedural approach for realizing prescriptive maintenance planning in manufacturing industries.  
Available at: <https://www-sciencedirect-com.ez.sun.ac.za/science/article/pii/S0007850617300070>
- Maxwell, J. (1996). *Qualitative Research Design: An Integrative Approach*. Thousand Oaks: SAGE publications Ltd.
- Medjaher, K., Zerhouni, N. and Baklouti, J. (2013 July). Data-driven prognostics based on health indicator construction: Application to pronostias data. *2013 European Control Conference, ECC 2013*, pp. 1451–1456.  
Available at: [https://www.researchgate.net/publication/261484081\\_Data-Driven\\_prognostics\\_based\\_on\\_health\\_indicator\\_construction\\_Application\\_to\\_PRONOSTIA's\\_Data/citation/download](https://www.researchgate.net/publication/261484081_Data-Driven_prognostics_based_on_health_indicator_construction_Application_to_PRONOSTIA's_Data/citation/download)
- Mehdipour, F., Javadi, B., Mahanti, A. and Ramirez Prado, G. (2019 January). *Fog Computing Realization for Big Data Analytics*, pp. 259–290.  
Available at: [https://www.researchgate.net/publication/330329179\\_Fog\\_Computing\\_Realization\\_for\\_Big\\_Data\\_Analytics](https://www.researchgate.net/publication/330329179_Fog_Computing_Realization_for_Big_Data_Analytics)
- Moens, P., Bracke, V., Soete, C., Hautte, S., Avendano, D., Ooijevaar, T., Devos, S., Volckaert, B. and Van Hoecke, S. (2020). Scalable fleet monitoring and visualization for smart machine maintenance and industrial iot applications. *Sensors*, vol. 20.

Available at: [https://www.researchgate.net/publication/343395795\\_Scalable\\_Fleet\\_Monitoring\\_and\\_Visualization\\_for\\_Smart\\_Machine\\_Maintenance\\_and\\_Industrial\\_IoT\\_Applications](https://www.researchgate.net/publication/343395795_Scalable_Fleet_Monitoring_and_Visualization_for_Smart_Machine_Maintenance_and_Industrial_IoT_Applications)

Mohammadpour, J., Franchek, M. and Grigoriadis, K. (2011 November). A survey on diagnostic methods for automotive engines. *International Journal of Engine Research*, vol. 13, no. 1, pp. 41–64.

Available at: <https://journals-sagepub-com.ez.sun.ac.za/doi/full/10.1177/1468087411422851>

Moniaga, J.V., Manalu, S.R., Hadipurnawa, D.A. and Sahidi, F. (2018). Diagnostics vehicles condition using obd ii and raspberry pi technology: study literature. *Journal of Physics: Conference Series*, vol. 978.

Available at: <https://iopscience-iop-org.ez.sun.ac.za/article/10.1088/1742-6596/978/1/012011>

Neethling, G. (2021 February). Personal interview. Epping.

Ochella, S. and Shafiee, M. (2019). Artificial intelligence in prognostic maintenance. *Proceedings of the 29th European Safety and Reliability Conference*.

Available at: <https://rpsonline.com.sg/proceedings/9789811127243/pdf/0188.pdf>

O'Donovan, P., Leahy, K. and O'Sullivan, D.T.J. (2015 November). An industrial big data pipeline for data driven analytics maintenance applications in large scale smart manufacturing facilities. *Journal of Big Data*, vol. 2, no. 1, pp. 1–26.

Available at: <https://www-proquest-com.ez.sun.ac.za/docview/1987954954?pq-origsite=primo>

O'Leary, T.J., Goul, M., Moffitt, K.E. and Radwan, A.E. (1990). Validating expert systems. *IEEE Intelligent Systems* 5.

Omoniwa, B., Hussain, R., Javed, M.A., Bouk, S. and Malik, S. (2018 October). Fog/edge computing based iot (feciot): Architecture, applications, and research issues. *IEEE Internet of Things Journal*.

Available at: [https://www.researchgate.net/publication/328243579\\_FogEdge\\_Computing-based\\_IoT\\_FECIoT\\_Architecture\\_Applications\\_and\\_Research\\_Issues](https://www.researchgate.net/publication/328243579_FogEdge_Computing-based_IoT_FECIoT_Architecture_Applications_and_Research_Issues)

- Palazuelos, A.R.T. and Droguett, E.L. (2021). System level prognostics and health management: A graph convolutional network based framework. *Journal of Risk and Reliability*, vol. 235, no. 1, pp. 120–135.  
Available at: <https://journals-sagepub-com.ez.sun.ac.za/doi/full/10.1177/1748006X20935760>
- Patil, A., Soni, G., Prakash, A. and Karwasra, K. (2022). Maintenance strategy selection: a comprehensive review of current paradigms and solution approaches. *The International journal of quality and reliability management*, vol. 39, no. 3, pp. 675–703. ISSN 0265-671X.  
Available at: <https://www-emerald-com.ez.sun.ac.za/insight/content/doi/10.1108/IJQRM-04-2021-0105/full/html>
- Pedram, M. and Wu, Q. (1999 June). Design considerations for battery-powered electronics. *IEEE 36th Design Automation Conference*, pp. 861–866.  
Available at: <https://dl.acm.org/doi/pdf/10.1145/309847.310089>
- Podsakoff, P.M., MacKenzie, S.B. and Podsakoff, P.P. (2016). Recommendations for creating better concept definitions in the organizational, behavioral, and social sciences. *Organizational Research Methods*, vol. 19, pp. 159–203.  
Available at: <https://journals-sagepub-com.ez.sun.ac.za/doi/pdf/10.1177/1094428115624965>
- Postelnicu, C. and Calea, S. (2019). The fourth industrial revolution. global risks, local challenges for employment. *Montenegrin journal of economics*, vol. 15, no. 2, pp. 195–206.  
Available at: <https://www.proquest.com/docview/2294465612?parentSessionId=HdGfm+39gxYh7EwvIiGFgNFspIvPcmxdiSzTgb+PkZQ=&pq-origsite=primo&accountid=14049>
- Prasad, B.V.P., Tang, J.J. and Luo, S.J. (2019 November). Design and implementation of sae j1939 vehicle diagnostics system. *2019 International Conference on Computation, Communication and Engineering*, pp. 71–74.  
Available at: [https://www.researchgate.net/publication/339554329\\_Design\\_and\\_Implementation\\_of\\_SAE\\_J1939\\_Vehicle\\_Diagnostics\\_System](https://www.researchgate.net/publication/339554329_Design_and_Implementation_of_SAE_J1939_Vehicle_Diagnostics_System)
- Puzakov, A.V. (2020). Operational monitoring concept of the vehicle power supply system. *2020 International Conference on Industrial Engineering, Applications and*



- Manufacturing (ICIEAM)*, pp. 1–5.  
Available at: <https://ieeexplore.ieee.org/stamp/stamp.jsp?tp=&arnumber=9112079>
- Quartes, N., Kockelman, K.M. and Mohamed, M. (2020). Costs and benefits of electrifying and automating bus transit fleets. *Sustainability 2020*, vol. 12, no. 10: 3977.  
Available at: <https://www.mdpi.com/2071-1050/12/10/3977>
- Radman, M.I. and Stelson, K. (2016). Optimal design of a power split hybrid hydraulic bus. *Journal of Automobile Engineering*, vol. 230, no. 12, pp. 1699–1718.  
Available at: <https://journals-sagepub-com.ez.sun.ac.za/doi/full/10.1177/0954407015621817>
- Rakytá, M., Fusko, M., Hercko, J., Zavodska, L. and Zrnic, N. (2016). Proactive approach to smart maintenance and logistics as a auxiliary and service processes in a company. *Applied Engineering Science*.  
Available at: <http://www.engineeringscience.rs/images/pdf/PROACTIVEAPPROACHTOSMART.pdf>
- Rashid, M., Nazeer, I., Gupta, K.S. and Khanam, Z. (2020 May). *Internet of Things: Architecture, Challenges and Future Directions*. IGI Global.  
Available at: [https://www.researchgate.net/publication/340133268\\_Internet\\_of\\_Things-Architecture\\_Challenges\\_and\\_Future\\_Directions](https://www.researchgate.net/publication/340133268_Internet_of_Things-Architecture_Challenges_and_Future_Directions)
- Robinson, S., Brooks, R., Kotiadis, K. and van der Zee, D.J. (2010). *Conceptual Modeling for Discrete Event Simulation*. 1st edn. Taylor and Francis Group, Baton Rouge.
- Roca Rui, M., Estrada, M. and Trapote, C. (2012 October). The design of interurban bus networks in city centers. *Transportation Research Part A: Policy and Practice*, vol. 46, no. 8, pp. 1153–1165.  
Available at: <https://www-sciencedirect-com.ez.sun.ac.za/science/article/pii/S0965856412000869>
- Rognvaldsson, T., Nowaczyk, S., Byttner, S., Prytz, R. and Svensson, M. (2017). Self-monitoring for maintenance of vehicle fleets. *Data Mining and Knowledge Discovery*, , no. 32, pp. 344–384.  
Available at: <https://link.springer.com/content/pdf/10.1007/s10618-017-0538-6.pdf>

Roy, R., Stark, R., Tracht, K., Takata, S. and Mori, M. (2016). Continuous maintenance and the future: Foundations and technological challenges. *CIRP Annals*, vol. 65, no. 2, pp. 667–688.

Available at: `file:///C:/Users/Admin/Downloads/1-s2.0-S0007850616301986-main(1).pdf`

Ryan, F., Coughlan, M. and Cronin, P. (2009). Interviewing in qualitative research: The one-to-one interview. *International Journal of Therapy and Rehabilitation*, vol. 16, no. 6, pp. 309–314.

SAEJ1939 (2017 April). Application-oriented manual. Germany.

Available at: [https://www.jetter.de/fileadmin/benutzerdaten/jetter-de/download-english/10\\_application-oriented\\_manual/sae\\_j1939\\_stx\\_api\\_101\\_application-oriented\\_manual.pdf](https://www.jetter.de/fileadmin/benutzerdaten/jetter-de/download-english/10_application-oriented_manual/sae_j1939_stx_api_101_application-oriented_manual.pdf)

Sanches, A., Loures, E. and De Lima, E. (2019). Use of promethee method for decision making in bus fleet maintenance proposal of framework.

Available at: <https://www.sciencedirect.com/science/article/pii/S2351978920302985?via=ihub>

Saunders, M.N.K., Lewis, P. and Thornbill, A. (2015). *Research Methods For Business Students*. Seventh edn. Essex, UK: Pearson Education.

Sinha, D. and Roy, R. (2020). Reviewing cyber physical system as a part of smart factory in industry 4.0. *IEEE Engineering Management Review*, vol. 48, no. 2, pp. 103–117.

Available at: <https://ieeexplore.ieee.org/document/9089269>

Stofer, K.A. (2019). Preparing for one on one qualitative interviews logistics. *EDIS*, , no. 4.

Available at: <https://edis.ifas.ufl.edu/pdf/WC/WC33800.pdf>

Struntz, M. (2012). *Instandhaltung: Grundlagen - strategien - werkstätten*. Berlin, Germany: Springer Vieweg.

Swanson, L. (2001). Linking maintenance strategies to performance. *International journal of production economics*.

Available at: <https://www-sciencedirect-com.ez.sun.ac.za/science/article/pii/S0925527300000670>

- Tamene, E.H. (2016). Theorizing conceptual framework. *Asian Journal of Educational Research*, vol. 4, no. 2, pp. 50–56.
- Tan, B.H.W. and Tiew, C.C.D. (2014). Building of a low-cost wireless battery analyzer. *2014 5th International Conference on Intelligent Systems, Modelling and Simulation*, pp. 765–771.
- Touqeer, H., Zaman, S., Amin, R., Hussain, M., Al Turjman, F. and Bilal, M. (2021 May). Smart home security: challenges, issues and solutions at different iot layers. *The Journal of Supercomputing*.  
Available at: <https://link-springer-com.ez.sun.ac.za/article/10.1007/s11227-021-03825-1>
- Trotter, L., Harding, M., Mikusz, M. and Davies, N. (2018). Iot-enabled highway maintenance: Understanding emerging cybersecurity threats. *IEEE pervasive computing*, vol. 17, no. 3, pp. 23–24.  
Available at: <https://ieeexplore-ieee-org.ez.sun.ac.za/stamp/stamp.jsp?tp=&arnumber=8490200>
- Trout, J. (2021). Maintenance management: An overview.  
Available at: <https://www.reliableplant.com/maintenance-management-31856>
- Tubis, A. and Werbinska-Wojciechowska, S. (2015). Concept of controlling for maintenance management performance: A case study of passenger transportation company.  
Available at: [https://www.researchgate.net/publication/282661946\\_Concept\\_of\\_controlling\\_for\\_maintenance\\_management\\_performance\\_A\\_case\\_study\\_of\\_passenger\\_transportation\\_company](https://www.researchgate.net/publication/282661946_Concept_of_controlling_for_maintenance_management_performance_A_case_study_of_passenger_transportation_company)
- Veldboom, B. (2021 June). How do i find the voltage of my car battery? *Batteries Plus Blog*.  
Available at: <https://www.batteriesplus.com/blog/power/find-voltage-of-car-battery>
- Veldman, J., Klingenberg, W. and Wortmann, H. (2011). Managing condition-based maintenance technology: A multiple case study in the process industry. *Journal of Quality in Maintenance Engineering*, vol. 17, pp. 40–62.  
Available at: <https://www-proquest-com.ez.sun.ac.za/docview/859632798?OpenUrlRefId=info:xri/sid:primo&accountid=14049>

- Velmurugan, R. and Dhingra, T. (2015). Maintenance strategy selection and its impact in maintenance function: a conceptual framework. *International Journal of Operations and Production Management*, vol. 35, pp. 1622–1661.
- von Bertalanffy, L. (1968). *General system theory: Foundations, development, applications*. G. Braziller.  
Available at: [https://monoskop.org/images/7/77/Von\\_Bertalanffy\\_Ludwig\\_General\\_System\\_Theory\\_1968.pdf](https://monoskop.org/images/7/77/Von_Bertalanffy_Ludwig_General_System_Theory_1968.pdf)
- Voss, W. (2008). *A Comprehensible Guide to J1939*. Copperhill Technologies Corporation. ISBN 978-0-9765116-3-2.  
Available at: <https://docplayer.net/137273969-A-comprehensible-guide-to-j1939.html>
- Winter, J. (2020). What is industry 4.0?  
Available at: <https://blog.isa.org/what-is-industry-40>
- Xi, Y., Salcedo, J.A., Zhou, Y., Liou, J.J. and Hajjar, J.J. (2015). Design and characterization of esd solutions with emc robustness for automotive applications. *Microelectronics Reliability*, vol. 55, no. 11, pp. 2236–2246.  
Available at: <https://www.sciencedirect.com/science/article/pii/S0026271415301748>
- Yazed, M.S.M. and Mahmud, F. (2017). The development of iot based bbt charting and monitoring using thingspeak. *AIP conference proceedings*, vol. 1788.
- Yi, S. and Li, Q. (2015 June). A survey of fog computing: Concepts, applications, and issues. *Proceedings of the 2015 Workshop on Mobile Big Data (Mobidata '15)*, pp. 37–42.  
Available at: [https://www.researchgate.net/publication/300490582\\_A\\_Survey\\_of\\_Fog\\_Computing\\_Concepts\\_Applications\\_and\\_Issues](https://www.researchgate.net/publication/300490582_A_Survey_of_Fog_Computing_Concepts_Applications_and_Issues)
- Yin, R.K. (1981). The case study crisis: Some answers. *Administrative Science Quarterly*, vol. 26, no. 1, pp. 58–65. ISSN 00018392.  
Available at: <http://www.jstor.org/stable/2392599>
- Zhang, X., Zhang, M. and Hu, Q. (2020 December). Research on the application of artificial intelligence in operation and maintenance for power equipment. *IOP Conference Series: Earth and Environmental Science*, vol. 617.

Available at: <https://iopscience-iop-org.ez.sun.ac.za/article/10.1088/1755-1315/617/1/012001>

Zheng, C. and Cha, S.W. (2017). Real time application of pontryagins minimum principle to fuel cell hybrid buses based on driving characteristics of buses. *International Journal of Precision Engineering and Manufacturing Green Technology*, vol. 4, no. 2, pp. 199–209.

Available at: <https://link-springer-com.ez.sun.ac.za/content/pdf/10.1007/s40684-017-0025-y.pdf>

# Appendices

# Appendix A

## Interviews

## A.1 Research Ethics Committee Approval



### NOTICE OF APPROVAL

REC: Social, Behavioural and Education Research (SBER) - Initial Application Form

24 November 2021

Project number: 23764

Project Title: Smart Maintenance System for Inner City Public Bus Services

Dear Mr PH De Villiers

Your REC: Social, Behavioural and Education Research (SBER) - Initial Application Form submitted on 06/10/2021 08:58 was reviewed and approved by the REC: Social, Behavioural and Education Research (REC: SBE).

Please note below expiration date of this approved submission:

#### Ethics approval period:

Protocol approval date (Humanities)	Protocol expiration date (Humanities)
24 November 2021	23 November 2024

#### GENERAL REC COMMENTS PERTAINING TO THIS PROJECT:

##### INVESTIGATOR RESPONSIBILITIES

Please take note of the General Investigator Responsibilities attached to this letter. You may commence with your research after complying fully with these guidelines.

**If the researcher deviates in any way from the proposal approved by the REC: SBE, the researcher must notify the REC of these changes.**

Please use your SU project number (23764) on any documents or correspondence with the REC concerning your project.

Please note that the REC has the prerogative and authority to ask further questions, seek additional information, require further modifications, or monitor the conduct of your research and the consent process.

##### CONTINUATION OF PROJECTS AFTER REC APPROVAL PERIOD

You are required to submit a progress report to the REC: SBE before the approval period has expired if a continuation of ethics approval is required. The Committee will then consider the continuation of the project for a further year (if necessary).

Once you have completed your research, you are required to submit a final report to the REC: SBE for review.

#### Included Documents:

Document Type	File Name	Date	Version
Data collection tool	Interview Questions 20749023	20/09/2021	1
Request for permission	Application-Letter-for-Institutional-Permission	05/10/2021	1
Informed Consent Form	Consent Form	05/10/2021	2
Default	Covid-19 Protocol	05/10/2021	2
Research Protocol/Proposal	Research Proposal Ethics	06/10/2021	3

If you have any questions or need further help, please contact the REC office at [cgraham@sun.ac.za](mailto:cgraham@sun.ac.za).

Sincerely,



APPENDIX A. INTERVIEWS

141

Clarissa Graham

REC Coordinator: Research Ethics Committee: Social, Behavioral and Education Research

*National Health Research Ethics Committee (NHREC) registration number: REC-050411-032.  
The Research Ethics Committee: Social, Behavioural and Education Research complies with the SA National Health Act No.61 2003 as it pertains to health research. In addition, this committee abides by the ethical norms and principles for research established by the Declaration of Helsinki (2013) and the Department of Health Guidelines for Ethical Research: Principles Structures and Processes (2<sup>nd</sup> Ed.) 2015. Annually a number of projects may be selected randomly for an external audit.*

### Principal Investigator Responsibilities

#### Protection of Human Research Participants

As soon as Research Ethics Committee approval is confirmed by the REC, the principal investigator (PI) is responsible for the following:

**Conducting the Research:** The PI is responsible for making sure that the research is conducted according to the REC-approved research protocol. The PI is jointly responsible for the conduct of co-investigators and any research staff involved with this research. The PI must ensure that the research is conducted according to the recognised standards of their research field/discipline and according to the principles and standards of ethical research and responsible research conduct.

**Participant Enrolment:** The PI may not recruit or enrol participants unless the protocol for recruitment is approved by the REC. Recruitment and data collection activities must cease after the expiration date of REC approval. All recruitment materials must be approved by the REC prior to their use.

**Informed Consent:** The PI is responsible for obtaining and documenting affirmative informed consent using **only** the REC-approved consent documents/process, and for ensuring that no participants are involved in research prior to obtaining their affirmative informed consent. The PI must give all participants copies of the signed informed consent documents, where required. The PI must keep the originals in a secured, REC-approved location for at least five (5) years after the research is complete.

**Continuing Review:** The REC must review and approve all REC-approved research proposals at intervals appropriate to the degree of risk but not less than once per year. There is **no grace period**. Prior to the date on which the REC approval of the research expires, **it is the PI's responsibility to submit the progress report in a timely fashion to ensure a lapse in REC approval does not occur**. Once REC approval of your research lapses, all research activities must cease, and contact must be made with the REC immediately.

**Amendments and Changes:** Any planned changes to any aspect of the research (such as research design, procedures, participant population, informed consent document, instruments, surveys or recruiting material, etc.), must be submitted to the REC for review and approval before implementation. Amendments may not be initiated without first obtaining written REC approval. The **only exception** is when it is necessary to eliminate apparent immediate hazards to participants and the REC should be immediately informed of this necessity.

**Adverse or Unanticipated Events:** Any serious adverse events, participant complaints, and all unanticipated problems that involve risks to participants or others, as well as any research-related injuries, occurring at this institution or at other performance sites must be reported to the REC within **five (5) days** of discovery of the incident. The PI must also report any instances of serious or continuing problems, or non-compliance with the RECs requirements for protecting human research participants.

**Research Record Keeping:** The PI must keep the following research-related records, at a minimum, in a secure location for a minimum of five years: the REC approved research proposal and all amendments; all informed consent documents; recruiting materials; continuing review reports; adverse or unanticipated events; and all correspondence and approvals from the REC.

**Provision of Counselling or emergency support:** When a dedicated counsellor or a psychologist provides support to a participant without prior REC review and approval, to the extent permitted by law, such activities will not be recognised as research nor the data used in support of research. Such cases should be indicated in the progress report or final report.

**Final reports:** When the research is completed (no further participant enrolment, interactions or interventions), the PI must submit a Final Report to the REC to close the study.

**On-Site Evaluations, Inspections, or Audits:** If the researcher is notified that the research will be reviewed or audited by the sponsor or any other external agency or any internal group, the PI must inform the REC immediately of the impending audit/evaluation.

## A.2 Consent Form



UNIVERSITEIT•STELLENBOSCH•UNIVERSITY  
jou kennisvennoot • your knowledge partner

**STELLENBOSCH UNIVERSITY  
CONSENT TO PARTICIPATE IN RESEARCH**

TITLE OF RESEARCH PROJECT:	Smart Maintenance System for Inner City Public Bus Services
REFERENCE NUMBER:	23764
PRINCIPAL INVESTIGATOR:	Paul-Roux de Villiers
ADDRESS:	5 Olyven Street, Paarl, 7646
CONTACT NUMBER:	079 038 6487
E-MAIL:	20749023@sun.ac.za

Dear Participants,

Kindly note that I am a Meng student at the Department of Industrial Engineering at Stellenbosch University, and I would like to invite you to participate in a research project entitled "Smart Maintenance System for Inner City Public Bus Services".

Please take some time to read the information presented here, which will explain the details of this project. Do not hesitate to contact me if you require further explanation or clarification of any aspect of the study. This study has been approved by the Research Ethics Committee (REC) at Stellenbosch University and will be conducted according to accepted and applicable national and international ethical guidelines and principles.

### 1. PURPOSE OF THE STUDY

The study investigates the use of Industry 4.0 technologies to digitalise the maintenance of inner city busses. Smart maintenance and Industry 4.0 technologies can be used to optimise maintenance in this sector to make the transport more reliable and save unnecessary expenditures. The purpose of the study is to develop a smart maintenance system for inner city public bus services.

### 2. WHAT WILL BE ASKED OF ME?

If you agree to take part in this study, you will be asked to take part in a structured online interview. Online interviews will be kept to a duration of one hour and will be done via a video call.

### 3. POSSIBLE RISKS AND DISCOMFORTS

There are no risks involved for any of the prospective participants.

#### **4. POSSIBLE BENEFITS TO PARTICIPANTS AND/OR TO THE SOCIETY**

Benefits with regard to participation is the contribution that they will be able to help improve the maintenance of inner city public bus services and ultimately improve their reliability by participating in the online interviews and sharing valuable experience.

#### **5. PAYMENT FOR PARTICIPATION**

No compensation will be provided for participant in this study.

#### **6. PROTECTION OF YOUR INFORMATION, CONFIDENTIALITY AND IDENTITY**

Any information shared during this study that could possibly identify the interviewee as a participant will be protected. The information gathered during the online interview will only be used for research purposes, specifically related to the investigator's thesis.

The identity of prospective participants will not be disclosed or published. The only form of personal data required is the participant's job title and area of expertise. In order to protect the prospective participant's privacy, their names and the name of their employer or the company they work for will not be disclosed.

The names of prospective participants will be replaced by ID codes in the research report. The research report will contain no direct quotes or links to any personal identifiers. The responses obtained during the online interview will be assigned a unique reference number, which will be used to identify data in the thesis itself.

Any form of correspondence between prospective participants and investigators will be kept confidential, and only the principal investigator and the research supervisor will have access to this information.

#### **7. PARTICIPATION AND WITHDRAWAL**

You can choose whether to be in this study or not. If you agree to take part in this study, you may withdraw at any time without any consequence. You may also refuse to answer any questions you don't want to answer and still remain in the study. The researcher may withdraw you from this study if you provide insufficient information.

If a participant decides to withdraw during an online interview, all responses they have given will be erased. In addition, if a participant wishes to withdraw after the online interview has been finished, none of their feedback will be used in the research and any records connected to their responses will be destroyed.

#### **8. RECORDINGS AND DATA STORAGE**

During online interviews, voice recordings will be used to allow the researcher to replay what was said to ensure that the information acquired is accurate. Apart from the lead investigator and the research supervisor, the recordings will not be shared with anyone else.

Only the principle investigator and the research supervisor will have access to the material acquired during the online interviews, which will be saved on the main researcher's computer. A personal password is required to gain access to the computer.

**9. RESEARCHERS' CONTACT INFORMATION**

If you have any questions or concerns about this study, please feel free to contact:

Paul-Roux de Villiers (Principal Investigator)  
[20749023@sun.ac.za](mailto:20749023@sun.ac.za)  
 079 038 6487

Wyhan Jooste (Supervisor)  
 wyhan@sun.ac.za

**10. RIGHTS OF RESEARCH PARTICIPANTS**

You may withdraw your consent at any time and discontinue participation without penalty. You are not waiving any legal claims, rights or remedies because of your participation in this research study. If you have questions regarding your rights as a research participant, contact Ms Maléne Fouché [[mfouche@sun.ac.za](mailto:mfouche@sun.ac.za); 021 808 4622] at the Division for Research Development.

.....

<b>DECLARATION OF CONSENT BY THE PARTICIPANT</b>
--

As the **participant** I confirm that:

- I have read the above information and it is written in a language that I am comfortable with.
- I have had a chance to ask questions and all my questions have been answered.
- I understand that taking part in this study is voluntary and I have not been pressurised to take part.
- I may choose to leave the study at any time and will not be penalised or prejudiced in any way.
- If the principal investigator feels that it is in my best interest, or if I do not follow the study plan as agreed to, then I may be asked to leave the study before it has finished.
- All issues related to privacy, and the confidentiality and use of the information I provide, have been explained.

By signing below, I \_\_\_\_\_ agree to take part in this research study, as conducted by Paul-Roux de Villiers.

\_\_\_\_\_  
**Signature of Participant**

\_\_\_\_\_  
**Date**

<b>DECLARATION BY THE PRINCIPAL INVESTIGATOR</b>
--

As the **principal investigator**, I hereby declare that the information contained in this document has been thoroughly explained to the participant. I also declare that the participant has been

encouraged (and has been given ample time) to ask any questions. In addition I would like to select the following option:

	The conversation with the participant was conducted in a language in which the participant is fluent.
	The conversation with the participant was conducted with the assistance of a translator (who has signed a non-disclosure agreement), and this "Consent Form" is available to the participant in a language in which the participant is fluent.

---

**Signature of Principal Investigator**

---

**Date**

## A.3 Institutional Permission

### A.3.1 Institutional Permission Application



UNIVERSITEIT • STELLENBOSCH • UNIVERSITY  
jou kennisvenoot • your knowledge partner

#### APPLICATION LETTER FOR INSTITUTIONAL PERMISSION

---

**INSTITUTION NAME & ADDRESS:**

**INSTITUTION CONTACT PERSON:**

**INSTITUTION CONTACT NUMBER:**

**INSTITUTION EMAIL ADDRESS:**

---

**TITLE OF RESEARCH PROJECT:** Smart Maintenance System for Inner City Public Bus Services

**ETHICS APPLICATION REFERENCE NUMBER:** 23764

**RESEARCHER:** Paul-Roux de Villiers

**DEPT NAME & ADDRESS:** Industrial Engineering, Stellenbosch University, Engineering Building, Industrial Department, Joubert Rd, Stellenbosch

**CONTACT NUMBER:** 079 038 6487

**EMAIL ADDRESS:** 20749023@sun.ac.za

---

Dear ...

Kindly note that I am a Meng student at the Department of Industrial engineering at Stellenbosch University, and I would appreciate your assistance with one facet of my research project.

Please take some time to read the information presented in the following four points, which will explain the purpose of this letter as well as the purpose of my research project, and then feel free to contact me if you require any additional information. This research study has been approved by the Research Ethics Committee (REC) at Stellenbosch University and will be conducted according to accepted and applicable national and international ethical guidelines and principles.

**1. A short introduction to the project:**

There are smart maintenance and Industry 4.0 technologies available that can be utilised to ensure and improve the reliability of busses at inner city public bus services. Smart maintenance and Industry 4.0 technologies can be used to optimise and digitalise maintenance in this sector to make the transport more reliable and save unnecessary expenditures.

**2. The purpose of the project:**

The study investigates the use of Industry 4.0 technologies to digitalise the maintenance of inner city busses. The purpose of the study is to develop a smart maintenance system for inner city public bus services.

**3. Your assistance would be appreciated in the following regard:**

Institutional permission is requested to be able to conduct a structured online interview with an employee in a maintenance manager role or similar position at the organisation. Online interviews will be kept to a duration of one hour and will be done via a video call.

**4. Confidentiality:**

Any information shared during this study that could possibly identify the interviewee as a participant will be protected. The information gathered during the online interview will only be used for research purposes, specifically related to the investigator's thesis. The identity of prospective participants will not be disclosed or published. The only form of personal data required is the participant's job title and area of expertise. In order to protect the prospective participant's privacy, their names and the name of their employer or the company they work for will not be disclosed. The names of prospective participants will be replaced by ID codes in the research report. The research report will contain no direct quotes or links to any personal identifiers. The responses obtained during the online interview will be assigned a unique reference number, which will be used to identify data in the thesis itself. Any form of correspondence between prospective participants and investigators will be kept confidential, and only the principal investigator and the research supervisor will have access to this information.

If you have any further questions or concerns about the research, please feel free to contact me via email (20749023@sun.ac.za) or telephonically (079 038 6487). Alternatively, feel free to contact my supervisor, Wyhan Jooste, via email (wyhan@sun.ac.za) or telephonically (021 808 4234).

Thank you in advance for your assistance in this regard.

Kind regards,  
Paul-Roux de Villiers  
Principal Investigator



### A.3.2 Institutional Permission Letter



#### INSTITUTIONAL PERMISSION LETTER

---

**INSTITUTION NAME & ADDRESS:**

**INSTITUTION CONTACT PERSON:**

**INSTITUTION CONTACT NUMBER:**

**INSTITUTION EMAIL ADDRESS:**

---

**TITLE OF RESEARCH PROJECT:** Smart Maintenance System for Inner City Public Bus Services

**ETHICS APPLICATION REFERENCE NUMBER:** 23764

**RESEARCHER:** Paul-Roux de Villiers

**DEPT NAME & ADDRESS:** Industrial Engineering, Stellenbosch University, Engineering Building, Industrial Department, Joubert Rd, Stellenbosch

**CONTACT NUMBER:** +27 79 038 6487

**EMAIL ADDRESS:** 20749023@sun.ac.za

---

Dear Paul-Roux de Villiers

We have reviewed your request to conduct a research project involving data related to an online structured interview regarding the maintenance of inner city public busses. You have permission to utilize the data for this project as define in your "Project Proposal".

Sincerely,

**Name:**

*Who warrants that he/she is duly authorised to sign on behalf of ...*

**Position:**

**Date:**

**Signature:**

---

## A.4 Interview Schedule

### Interview Schedule

#### PART 1

##### Question 1

Describe your experience and involvement as a maintenance practitioner at an inner city bus services.

- a) What is your role/position?
- b) In what area is your expertise/knowledge? (In terms of the maintenance process)
- c) Do you currently follow a specific maintenance strategy?
  - No strategy
  - Reactive Maintenance
  - Preventive maintenance
  - Condition-based maintenance (CBM)
  - Predictive maintenance
  - Smart maintenance

*When a **reactive maintenance** strategy is implemented, equipment is allowed to run to failure before it is repaired or replaced (Swanson, 2001).*

***Preventive maintenance** is "maintenance carried out intended to assess and/or mitigate degradation and reduce the probability of failure of an item" (DINEN13306, 2018). This type of maintenance depends on the estimated likelihood that the equipment has a specified interval within which it will fail (Swanson, 2001).*

***CBM** is "preventive maintenance which includes assessment of physical conditions, analysis and the possible ensuing maintenance actions" (DINEN13306, 2018). CBM can also be viewed as a type of preventive maintenance that is more effectively scheduled and ideally performed just before failure (Jonge, 2017).*

***Predictive maintenance** is "condition-based maintenance carried out following a forecast derived from repeated analysis or known characteristics and evaluation of the significant parameters of the degradation of the item" (DINEN13306, 2018).*

***Smart maintenance** is "learning-orientated, self-regulated, intelligent maintenance with the objective of maximising the technical and economic effectiveness of maintenance measures taking into account the respective existing production system by using digital applications" as defined by Henke et al. (2019, p. 11).*

- d) How do you document your maintenance information/process?
  - No documentation
  - By hand
  - CMMS (Computerised Maintenance Management System)
  - Other (Specify)
- e) What type of data is utilised to initiate maintenance practices?

- No data
  - Service history data
  - Real-time data
- f) Generally, where do you see the most potential for the optimisation of maintenance in your industry?

**PART 2****Question 2**

Which of the principal requirements of the following Industry 4.0 technologies do you implement in your maintenance practices?

Technology	Principal Requirement	Yes/No	Maturity
Big data & analytics	Capability to collect and store data		
	Digital data management system		
	Data analytics to generate insight		
Internet of Things	Network to collect, store, and use data		
	Discover knowledge from stored data		
	Interface to provide user access		
Cloud computing	Internet access		
	Cloud IT capability		
	Virtual centralisation of data		
Cyber-physical system	Sensors to acquire data from machines		
	Connected machine network		
	Remotely control equipment function		
Artificial intelligence	Self-learning system capability		
	Intelligent decision-making machines		
	Utilise algorithms for decision-making		

(The maturity of each technology can be determined with the number of principal requirements met for each technology)

- ✓ None: Has not been implemented. (0 - Yes)
- ✓ Initiated: Concept has been initiated or partly operational. (1 to 2 - Yes)
- ✓ Mature: Installed and fully operational. (3 - Yes)

**Big Data** can be defined as large volume, high-speed information consisting of structured and unstructured data (Roy, 2016).

**IoT** can be defined as "an intelligent pervasive environment, based on a continuing proliferation of intelligent networks, wireless sensors and massive data centres" (Ayab,

2018). *The basic vision of IoT is that nearly everything thing in the physical world can become a computer that is connected to the internet (Ayab, 2018).*

*The **Cloud** allows information and computing resources to be accessed from anywhere and also provides virtual centralisation of data and computing applications (Mehdipour, 2019).*

*CPS involves interconnecting physical objects using local or global data networks (Roy, 2016). Connecting assets in the industrial environment to the internet using smart sensors creates a CPS of interlinked machines (Moens, 2020).*

*The goal of **AI** is to use machines to perceive human-like intelligence to allow for recognition, cognition, classification, and decision-making (Zhang, 2020).*

### **PART 3**

#### **Question 3**

What are the main factors influencing the degradation of the reliability of an inner city bus? Rank answer from most relevant.

- Driving style
- Unknow health status
- Unreliable replacement components
- Maintenance implementation method
- External operating conditions (For example traffic or road conditions)

#### **Question 4**

What are the key mechanical components that are responsible for the most down time of inner city busses? Rank key components. (Maximum five)

#### **Question 5**

How can the unit life of key components be improved?

- Industry 4.0 technologies
- Different maintenance strategy
- Improved driving style
- Other (Specify)

#### **Question 6**

What kind of historical service data is available on the identified key components?

- No data
- Partial historical data
- Detailed historical data

**PART 4****Question 7**

Are diagnostic and/or prognostic information utilised in the maintenance of the busses (In terms of a Prognostic and Health Management maintenance approach):

Diagnostic information:

- Yes
- No

Prognostic information:

- Yes
- No

*Diagnosics focuses on the detection and identification of faults (Ayab, 2018).*

*According to Killeen (2020, p. 18), prognosics is the process of predicting the health status of equipment that is being monitored.*

**Question 8**

How often would you prefer health status updates and detection?

- Real-time
- Hourly
- Daily
- Weekly
- Not interested

**Question 9**

How can smart maintenance support or improve your maintenance? Rank your answer from most desirable.

- Real-time condition monitoring
- Remaining useful life estimation
- Decision support

**Question 10**

What are the important aspects to consider when implementing smart maintenance? Rank answer from most important.

- Level of employee skills
- Availability of funds
- Data security
- Maturity of technologies
- Degree of digitalisation

**Question 11**

Rate the importance of the following requirements of a future, smart, maintenance planning system: (One being less important and five being important)

<b>Requirement</b>	<b>Score (1-5)</b>
Support in maintenance strategy selection	
Improvement of the utilisation of machine assemblies and components (Wear models and remaining service life assessments)	
Accelerated maintenance planning	
Increase in planning quality (Utilisation of accurate data)	
Improvement of usability (Make planning easier)	
Flexibility of IT systems, reduction of the effort required for networking	
Structure functions modularly that will allow for quick adaption to application specific scenarios	

# Appendix B

## Concept Demonstrator

### B.1 Parts List and Cost

**Table B.1:** Concept demonstrator parts list and cost

	<b>Part</b>	<b>Price (Rand)</b>
1	<i>NodeMCU ESP8266</i>	89
2	Voltage divider	26
3	Electrical wires	48
4	Mounting box	97.75
5	Two resistors	0.56
6	Microchip board	29
7	Wire connectors	29.75
8	Insulation tape	5.95
9	Micro USB charging cable	22
10	1 A Fuse	1.50
11	Fuse holder	28
12	5 Meter electrical wire	29
13	PVC oval gland	3.40
14	Two PVC saddles	3.06
	<b>Total Cost (Rand) Excl. Tax</b>	<b>412.97</b>
	<b>Total Cost (Rand) Incl. Tax</b>	<b>474.92</b>

## B.2 Arduino IDE Programming

```
#include <ESP8266WiFi.h>
#include <ESP8266WiFiMulti.h> //
Include the Wi-Fi-Multi library

ESP8266WiFiMulti wifiMulti; //
Instance of the ESP8266WiFiMulti class, called 'wifiMulti'

String apiKey = "9UTJVTCMN4VIRBBU"; // API
key from ThingSpeak

const char *ssid = "HP-20749023"; // Wifi
ssid and wpa2 key
const char *pass = "Paul-Roux20749023";
const char* server = "api.thingspeak.com";
const int voltageSensor = A0; // Define
analogue input

float vOUT = 0.0;
float v = 0.0;
float R1 = 981.0; // Measured R1 resistor
value of voltage divider
float R2 = 99.0; // Measured R2 resistor value
of voltage divider
int value = 0;
float calibration = 0.99; // Voltage calibration factor

WiFiClient client;

void setup()
{
    Serial.begin(115200); // Upload speed
    delay(10);

    wifiMulti.addAP("HP-20749023", "Paul-Roux20749023");
```



```
// Additional Wi-Fi networks to connect to
wifiMulti.addAP("AndroidAP3305", "PaulRoux");
wifiMulti.addAP("DE VILLIERS", "0834629712");
wifiMulti.addAP("Engineering-Test", "G10b@lTeams");

Serial.println("Connecting ...");
int i = 0;
while (wifiMulti.run() != WL_CONNECTED) { // Wait for
Wi-Fi to connect: Scan for Wi-Fi networks, and connect to
the strongest of the networks defined above
  delay(1000);
  Serial.print('.');
}
Serial.println('\n');
Serial.print("Connected to ");
Serial.println(WiFi.SSID()); // Show what
network is connected to
Serial.print("IP address:\t");
Serial.println(WiFi.localIP()); // Send the
IP address of the NodeMCU ESP8266 to the computer

}

void loop()
{
    value = analogRead(voltageSensor); //
Read analogue voltage reading
    vOUT = (value * 3.20) / 1024.0; // To
convert signal
    v = vOUT / (R2/(R1+R2)) - calibration; //
Voltage division equation with calibration value
subtracted
```

```
        if (v <= 23.8) // If voltage is equal to or
smaller than 23.8 V wait 5 minutes and measure as well as
compute again.
        {

                delay(300000); // Delay in
milliseconds [5min = 300 000ms]

                value =
analogRead(voltageSensor);
                vOUT = (value * 3.20) / 1024.
0;

                v = vOUT / (R2/(R1+R2)) -
calibration;
        }

        if (isnan(v))
        {
                Serial.println("Failed to read from
Voltage sensor!");
                return;
        }

                if (client.connect(server,80))
                {

                        String postStr =
```

```

apiKey;

                                postStr += "&field1=";
                                postStr += String(v);
                                postStr += "\r\n\r\n";

                                client.print("POST /update
HTTP/1.1\n");
                                client.print("Host:
api.thingspeak.com\n");
                                client.print("Connection:
close\n");
                                client.
print("X-THINGSPEAKAPIKEY: "+apiKey+"\n");
                                client.print("Content-Type:
application/x-www-form-urlencoded\n");
                                client.
print("Content-Length: ");
                                client.print(postStr.
length());
                                client.print("\n\n");
                                client.print(postStr);

                                Serial.print(v);
                                Serial.println("Volt");
                                }
                                client.stop();
                                Serial.println("Waiting...");
                                ESP.deepSleep(1800e6);           // Sleeps for a
defined amount of time before executing code again
(Defined in microseconds) [1800s = 30min]

}

```