

# **A FEASIBILITY STUDY OF UTILISING SHIPPING CONTAINERS TO ADDRESS THE HOUSING BACKLOG IN SOUTH AFRICA**

by

**Antoni Willem Botes**

*Thesis presented in partial fulfilment of the requirements for the degree*

**Master of Engineering (Construction Management)**

*at Stellenbosch University*



Faculty of Engineering  
Civil Department  
Construction Management Division

Promotor:

Prof. Jan A. Wium

December 2013

## DECLARATION

By submitting this thesis electronically, I declare that the entirety of the work contained therein is my own, original work, that I am the authorship owner thereof (unless to the extent explicitly otherwise stated) and that I have not previously in its entirety or in part submitted it for obtaining any qualification.

Signature: .....

Antoni W. Botes

Date: .....

December 2013

## ABSTRACT

### **A Feasibility Study of Utilising Shipping Containers to Address the Housing Backlog in South Africa**

**A.W. Botes**

Thesis: M.Eng. (Research)

December 2013

The current housing backlog facing the informal residents of South Africa is daunting. With current research showing that the backlog is not shrinking fast enough, the stakeholders of the formal and informal housing sector are facing an immense challenge. Most houses constructed after 1994 utilised conventional brick and mortar construction, with alternative means of building homes taking up a negligible share in the total housing supply.

The purpose of this study is to test the feasibility of container-based homes as an alternative to brick and mortar homes in South Africa's low-cost housing supply according to the triple constraints of project management i.e. cost, time and quality. Social acceptance and environmental sustainability are also analysed as two secondary parameters that will influence container-based projects. These parameters form the basis of the three pillars of sustainability, i.e. economic, societal and environmental parameters, which indicates the feasibility of a new design implementation.

Two test cases for the feasibility study were designed. The first case considers a modular single-storey residential home, equivalent to standard "Breaking New Ground" housing solutions. The second test case considers a multi-storey, medium-density residential building, capable of housing multiple families. The test cases represent possible container-based solutions, with traditional brick and mortar construction (single and multi-storey) acting as the control solution. The three sustainability parameters act as benchmarks of each solutions' feasibility, with the control solution acting as the counter-performance example.

The comparison of the economic parameter relies on the cost of each design case, its construction time and the quality of the end-product. The bills of quantities were measured against a conventional building type, and it was found that a single-storey solution will prove more costly than a small brick and mortar home. However, the multi-storey solution proves to be feasible when compared to a concrete three-storey structure. Regarding time, the construction of an Intermodal Steel Building Unit (ISBU) home is up to 3 times faster compared

to a conventional house. The end-product quality will depend on the quality system used by the contractor and its correct implementation; thus it is not an important dividing factor when comparing conventional versus Alternative Building Technology (ABT) systems.

The societal parameter of an ISBU solution rests on its acceptance by the beneficiaries. Traditionally, resistance has met ABT home implementation, as stakeholders consider them as inferior products. A comprehensive survey was carried out in an informal settlement to test this statement. The results show that the majority of beneficiaries prefer conventional homes, unless the ABT home resembles its conventional counterpart.

The environmental sustainability of a new product relies primarily on the carbon footprint of the materials and methods used. This was tested by comparing the impact of an ISBU solution with a conventional solution. The “upcycling” (as opposed to recycling) of used containers provides a large environmental benefit when comparing it to newly constructed brick for conventional homes, and thus the impact is lower.

The findings of the study show that a single-storey solution utilising containers proves ineffective, as it is more expensive per square meter than a conventional home. However, a multi-storey container solution is feasible, as it is lower in cost (than comparative conventional solutions), faster to construct, allows for higher density expansion of settlements and is more environmentally friendly.

**Keywords:** ABT, ISBU, alternative building methods, container, low-cost, housing, South Africa



## OPSOMMING

### **A Feasibility Study of Utilising Shipping Containers to Address the Housing Backlog in South Africa**

**A.W. Botes**

Tesis: M.Ing. (Navorsing)

Desember 2013

Die enorme behuisingsagterstand van informele nedersetters in Suid-Afrika skep 'n geweldige uitdaging vir die rolspelers in die formele behuisingsektor. Huidige navorsing toon dat hierdie agterstand nie vinnig genoeg verminder nie, en baie mense verkeer in nood. Die meerderheid van huise wat opgerig is sedert 1994 maak gebruik van konvensionele baksteen en sement konstruksie, terwyl alternatiewe maniere van konstruksie 'n nietige aandeel het.

Die doel van hierdie studie is om die bruikbaarheid van skeepshouer-gebaseerde huise te bepaal in teenstelling met konvensionele baksteen en sement huise, spesifiek vir die lae-koste behuisingsgeval in Suid-Afrika. Dit word uitgevoer volgens die "drietallige beperking" beginsel van projekbestuur, naamlik koste, tyd en kwaliteit parameters. Addisioneel word die sosiale aanvaarbaarheid sowel as die omgewingsvriendelikheid van die konsep getoets teen konvensionele maniere van konstruksie. Hierdie parameters vorm saam die "drie pilare van volhoubaarheid", wat betrekking het tot ekonomiese-, sosiale- en omgewings-aspekte.

Twee toetsgevalle is ontwerp volgens argitektoniese en tegniese standaarde sowel as gemeenskap benodigdhede. Die eerste geval is ontwerp as 'n enkel-verdieping huis, met behulp van modulêre skeepshouers. Die tweede geval is 'n meertallige-verdieping, mediumdigtheid residensiële gebou wat verskeie families kan huisves. Die toetsgevalle modelleer verskeie skeepshouer oplossings, terwyl konvensionele konstruksie oplossings dien as beheer gevalle. Elke geval word volgens die drie volhoubaarheids beginsels getoets, met die beheer gevalle wat dien as die teen-prestasie voorbeelde.

Die vergelyking van die ekonomiese parameter berus op die koste van elke ontwerp, sy konstruksie tyd en die eindproduk kwaliteit. Die lys van hoeveelhede is gemeet teen dié van 'n konvensionele huis, en daar is bevind dat die enkelverdieping skeepshouer-geval veel duurder sal wees. Die meertallige-verdieping geval aan die ander kant, maak gebruik van baie kostebesparings metodes, en lyk uitvoerbaar. Die tyd-aspek wys dat die konstruksie m.b.v. "Intermodal Steel Building Units" (ISBUs) tot en met 3 keer vinniger te wees teenoor 'n

konvensionele huis. Die eindproduk kwaliteit hang af van die tipe kwaliteit stelsel wat die kontrakteur gebruik, sowel as die korrekte toepassing van hierdie stelsel; dus is dit nie 'n skeidende faktor tussen alternatiewe en konvensionele boumetodes nie.

Die gemeenskaplike aspek van die gebruik van alternatiewe konstruksie berus op die aanvaarding van die huisbewoners. Gemeenskappe het tradisioneel nie 'n hoë dunk van Alternatiewe Bou-Tegnologie (ABT) behuising nie, aangesien hulle dit as swak kwaliteit bestempel. Om hierdie stelling te toets is 'n opname uitgevoer in 'n informele nedersetting. Die resultate wys dat die meerderheid inwoners die konvensionele opsie verkies. Daar is wel bevind dat die inwoners 'n ISBU huis sal oorweeg indien dit 'n visuele ooreenkoms toon met 'n konvensionele huis.

Die omgewingsvolhoubaarheid van 'n nuwe produk berus hoofsaaklik op die koolstofvoetspoor van die materiale en boumetodes wat gebruik is. Hierdie aspek is getoets deur 'n ISBU oplossing se omgewings-impak te meet teen dié van 'n konvensionele huis. Die "upcycling" voordeel wat skeepshouers gebruik gee 'n groot voordeel teenoor die konstruksie van konvensionele huise, siende dat min nuwe materiale gebruik word. Dus is die totale omgewings impak laer as die van 'n konvensionele huis.

Die bevindinge van die navorsing wys dat 'n enkelverdieping ISBU oplossing onprakties is in terme van koste per vierkante meter, aangesien dit veel duurder as 'n konvensionele metode is. Die meertallige-verdieping geval is wel uitvoerbaar, aangesien dit 'n laer koste tot gevolg het, vinniger gebou word, hoër-digtheid behuising bevorder en meer omgewings-vriendelik is.

**Sleutelbegrippe:** ABT, ISBU, alternatiewe boumetodes, skeepshouer, lae-koste, Suid-Afrika

## ACKNOWLEDGEMENTS

I would like to acknowledge the contributions of the following people and entities who helped me bring this research report into being:

- To my supervisor, Prof. Jan Wium, who provided me with guidance, support and many hours of proofreading. I am very grateful for all your help.
- To the Civil Construction Management Department, Engineering Faculty, University of Stellenbosch for funding my research.
- To the five survey assistants who helped me conduct the sociological survey in Caledon, Western Cape, South Africa.
- My personal thanks to the members and councillors of the Theewaterskloof Municipality for their help in the planning, construction and execution of the survey.
- To Fabricated Steel Manufacturing (Johannesburg), for the information provided regarding Alternative Building Technologies, container refurbishment/conversion and the accompanying costs.
- To Spazatainer and Containerworld, for their input on second-hand container pricing in South Africa.
- To Michael Hart Architects, for their contribution regarding modern residential buildings built from ISBUs, as well as integrated planning and urbanisation in the South African context.
- To Johan Keuler from Aurecon South Africa, for his valuable insight into low-cost and gap housing in South Africa.
- To James Kennedy, for the costing data provided on different container-based ISBU solutions.
- To André Botes and Jan Kennedy, who provided in-depth construction and physical details when utilising containers in building projects.
- To all my friends and fellow research colleagues, who helped me by providing advice, ideas and encouragement.
- To my significant other, Estie, who supported me during the many days and nights of research, typing and proofreading. I love you with all my heart.
- Finally, to both my parents, who provided me with the education and wonderful support to follow my dreams, and endeavour to make the world a better place. Thank you so much, Mom and Dad.

## TABLE OF CONTENTS

DECLARATION .....	i
ABSTRACT.....	ii
OPSOMMING .....	iv
ACKNOWLEDGEMENTS .....	vi
TABLE OF CONTENTS .....	vii
LIST OF FIGURES .....	xii
LIST OF TABLES.....	xv
LIST OF EQUATIONS .....	xv
LIST OF ABBREVIATIONS.....	xvi

<b>Chapter</b>	<b>Chapter Description</b>	<b>Page</b>
<b>Number</b>		<b>Number</b>
1	INTRODUCTION .....	1
1.1	Background.....	1
1.2	Problem Statement .....	2
1.3	Research Statement .....	2
1.4	Research Methodology .....	3
1.5	Objectives of the Study .....	4
1.6	Chapter Overview .....	4
2	LITERATURE REVIEW ON AFFORDABLE HOUSING IN SOUTH AFRICA AND ISBU ALTERNATIVES.....	7
2.1	Introduction.....	7
2.2	The Context of Low-Cost Housing in South Africa.....	8
2.2.1	History of Housing in South Africa.....	8
2.2.2	Housing Framework, Policies, Regulatory Authorities and Subsidy-Based Assistance Programmes .....	10
2.2.3	Current Challenges to Effective Housing Delivery .....	17
2.2.4	Alternative Building Technologies and the Housing Backlog .....	25
2.2.5	Problem Definition for Housing in South Africa.....	32
2.3	Shipping Containers as an Alternative Building Technology.....	33

<b>Chapter Number</b>	<b>Chapter Description</b>	<b>Page Number</b>
2.3.1	The History of the Intermodal Freight Container.....	33
2.3.2	Container Applications.....	38
2.3.3	Aspects of Containers as Building Modules.....	39
2.3.4	As an Alternative Solution for the Affordable Housing Market.....	41
2.4	Conclusion.....	42
3	RESEARCH DESIGN AND METHODOLOGY.....	43
3.1	Introduction.....	43
3.2	Research Aim and Objectives.....	43
3.3	Research Approach and Design.....	44
3.3.1	The Principles of Sustainability.....	44
3.3.2	The Economic Parameter.....	45
3.3.3	The Societal Parameter.....	45
3.3.4	The Environmental Parameter.....	46
3.3.5	Test Case Design.....	46
3.4	Research Instruments.....	46
3.4.1	Construction & Manufacturer Data.....	46
3.4.2	Case Studies.....	47
3.4.3	Descriptive Survey.....	47
3.5	Limitations of the Study.....	47
3.6	Ethical Considerations.....	48
3.7	Chapter Conclusion.....	48
4	ISBU TEST CASE REQUIREMENTS AND DESIGN.....	50
4.1	Introduction.....	50
4.2	Design and Testing Requirements.....	50
4.2.1	Requirements for Addressing the Challenges of the Housing Backlog.....	51
4.2.2	ISBU Design Optimisations.....	52
4.2.3	NHBRC Compulsory Requirements and SANS Codes of Practice.....	54
4.3	Concept Test Case Design.....	57
4.3.1	Overall Design Plan.....	57
4.3.2	Top Structure Analysis of 12m ISBU Configuration and Design.....	60

<b>Chapter Number</b>	<b>Chapter Description</b>	<b>Page Number</b>
4.3.3	Insulation, Internal Walls and Finishing .....	67
4.3.4	Roof .....	68
4.3.5	Foundation.....	68
4.3.6	Construction Method Statement.....	68
4.3.7	Durability of Structure and Expected Maintenance.....	69
4.4	Final Test Case Designs for Feasibility Analysis .....	69
4.4.1	Low-Density ISBU Housing Concept Design, Test Case 1.....	70
4.4.2	Medium-Density ISBU Housing Concept Design, Test Case 2.....	70
4.5	Conclusion .....	71
5	COST, TIME, SUPPLY AND QUALITY ASSURANCE OF ISBU HOUSING.....	72
5.1	Introduction .....	72
5.2	Case Studies .....	72
5.2.1	61 Countesses Ave, Windsor Park, Randburg .....	72
5.2.2	Community Residential Unit Project, Cape Metropolis, Cape Town .....	73
5.2.3	Watergang Housing Project, Kayamandi, Stellenbosch .....	74
5.3	Manufacturer Data .....	74
5.3.1	Cost of New Intermodal Freight Containers .....	75
5.3.2	Shipping Companies and the Used Container Supply in South Africa.....	75
5.3.3	Container Refurbishment .....	75
5.3.4	Container Transport and Erection .....	76
5.3.5	ISBU Conversion .....	77
5.4	Shipping Container Supply in South Africa.....	77
5.5	Comparison of Construction Costs and Time.....	78
5.5.1	Assumptions .....	78
5.5.2	Comparison of Costs .....	78
5.5.3	Comparison of Construction Time.....	82
5.6	Commentary on Quality Assurance of Final Product .....	83
5.7	Conclusion .....	84
6	SOCIAL ACCEPTANCE OF ISBU HOUSING .....	85
6.1	Introduction .....	85

<b>Chapter Number</b>	<b>Chapter Description</b>	<b>Page Number</b>
6.2	Negative Perception of Alternative Housing Solutions.....	85
6.3	Survey Investigation of Negative ABT Perception .....	86
6.4	The Social Aspects of Housing .....	87
6.4.1	Housing Needs .....	87
6.4.2	Housing Norms .....	89
6.4.3	Housing Preferences .....	90
6.4.4	Relationship between Needs, Norms and Preferences .....	91
6.5	Survey Methodology .....	92
6.5.1	Objectives .....	92
6.5.2	Survey Questionnaire Design .....	92
6.5.3	Interviewing and Training of Assistants .....	95
6.5.4	Location and Size of Survey .....	95
6.5.5	Selection of Respondents .....	97
6.6	Survey Results and Discussion.....	97
6.6.1	Respondent Profile .....	97
6.6.2	Uninformed Preference for ISBU or Conventional Housing .....	101
6.6.3	Preference for ISBU or Conventional Housing, with Perfect Information .....	106
6.7	Conclusion .....	108
7	ENVIRONMENTAL IMPACT OF ISBU HOUSING .....	110
7.1	Introduction .....	110
7.2	Background to the Quantitative Environmental Impact Modelling.....	110
7.2.1	Acidification Potential.....	111
7.2.2	Resource Depletion .....	111
7.2.3	Waste Generation .....	111
7.2.4	Normalisation and Weighting Factors .....	112
7.3	Environmental Impact of Conventional Homes.....	113
7.3.1	Assumptions .....	113
7.3.2	Results for Conventional Single-storey Control Case.....	113
7.4	Environmental Impact of ISBU Homes .....	116
7.4.1	Assumptions .....	116

<b>Chapter Number</b>	<b>Chapter Description</b>	<b>Page Number</b>
7.4.2	Results for ISBU Single-storey Test Case.....	117
7.5	Comparison between Systems.....	121
7.6	Conclusion.....	122
8	CONCLUSION AND RECOMMENDATIONS.....	123
8.1	Summary.....	123
8.2	Discussion of Feasible and Non-feasible Cases.....	125
8.3	Recommendations for Future Research.....	126
9	LIST OF REFERENCES.....	127
10	ANNEXURES.....	134
	ANNEX A: RACIAL DISTRIBUTION ACCORDING TO 2011 CENSUS.....	135
	ANNEX B: CONTAINER DRAWINGS AND FEA MODELLING DETAILS.....	137
	ANNEX C: ISBU LIFTING FEM, LOAD CALCULATIONS.....	140
	ANNEX D: ISBU STATIC PERMA-LOAD FEM, LOAD CALCULATIONS.....	141
	ANNEX E: CONVENTIONAL BILL OF QUANTITIES.....	143
	ANNEX F: ISBU BILL OF QUANTITIES.....	144
	ANNEX G: SURVEY QUESTIONNAIRE.....	146
	ANNEX H: SURVEY PHOTOSHEETS.....	148
	ANNEX I: SURVEY INFORMATION SHEETS.....	152
	ANNEX J: ENVIRONMENTAL IMPACT CALCULATIONS.....	153



## LIST OF FIGURES

<b>Figure 2.1</b> - Household distribution per income level according to the Statistics SA 2005/2006 Income and Expenditure Survey (K. Rust, 2009).....	19
<b>Figure 2.2</b> - Yearly investment in SA construction industry based on market segment, adjusted for 2005 values (Adapted from Industry Insight - The State of SA Construction Industry, June 2011). .....	22
<b>Figure 2.3</b> - Types of Alternative Building Technology Housing Systems. ....	27
<b>Figure 2.4</b> - A modular prefabricated home (Fabricated Steel Manufacturing, 2013). ....	28
<b>Figure 2.5</b> - A manufactured house (Fabricated Steel Manufacturing, 2013). ....	28
<b>Figure 2.6</b> - A mobile home partway under construction (Melton, 2008). ....	29
<b>Figure 2.7</b> - A hybrid home utilising ISBUs as well as a panelled system (RO/LU Design, 2007). ....	30
<b>Figure 2.8</b> - Tramway wagon components (adapted from photograph by R. Bradley, 2013). .....	34
<b>Figure 2.9</b> - Little Eaton tramway (R. Bradley, 2013). ....	35
<b>Figure 2.10</b> - The "SS Ideal X", the first ship to carry modern, intermodal freight containers (D. Eaves).....	37
<b>Figure 2.11</b> - The most common variants of containers found in South Africa today: the 20-footer (6m in length), and the 40-footer (12m in length).....	37
<b>Figure 2.12</b> - Redondo Beach Container House (Container Atlas, 2010).....	38
<b>Figure 2.13</b> - Different possible ISBU stacking configurations. ....	39
<b>Figure 2.14</b> - Common freight container sizes (Adapted from Slawik, 2010).....	40
<b>Figure 3.1</b> - The "Three Pillars" of Sustainability (Adapted from Adams, 2006).....	45
<b>Figure 4.1</b> - On-site manufacturing of ISBU residential building (M. Hart, 2013).....	53
<b>Figure 4.2</b> - Spaced container design for offices (FSM, 2013). ....	53
<b>Figure 4.3</b> - Early concept layout of 12m container, which acts as the ISBU house main component. This module has an approximate floor area of 28.5m <sup>2</sup> . ....	58
<b>Figure 4.4</b> - Early concept layout for low- and medium-density hybrid-ISBU housing test cases using 12m containers. This configuration provides two apartment units with an approximate floor area of 48m <sup>2</sup> each. ....	58
<b>Figure 4.5</b> - Early concept configurations for low-density, single-storey hybrid-ISBU housing, with a galvanised roof (6m container- and 12m hybrid versions). ....	59
<b>Figure 4.6</b> - Early concept configurations for medium-density, multi-storey hybrid-ISBU housing, with a galvanised roof (6m container- and 12m hybrid versions). ....	59
<b>Figure 4.7</b> - FEM shell modelling for container with living space, window and door cutouts.	61

<b>Figure 4. 8</b> – FEM beam model, showing the container frame, chassis and gooseneck tunnel. .....	62
<b>Figure 4.9</b> - Completed FEM 3D model. ....	62
<b>Figure 4.10</b> - FEM results for lifting case with a distributed load of 2 tons.....	63
<b>Figure 4.11</b> - FEM deflection shape for lifting case with a distributed load of 2 tons. ....	64
<b>Figure 4.12</b> - FEM results for static loading case.....	65
<b>Figure 4.13</b> - FEM deflection shape for static loading case.....	66
<b>Figure 4.14</b> - EPS slab permanent formwork system.....	66
<b>Figure 4.15</b> - EPS sheets with wire mesh, and applied shotcrete-type coating. ....	67
<b>Figure 4.16</b> - Plan view of test case designs. ....	69
<b>Figure 4.17</b> - Test Case 1: Single-storey, low-density ISBU Housing .....	70
<b>Figure 4.18</b> - Test Case 2: Single-storey, medium-density ISBU Housing .....	71
<b>Figure 5.1</b> - Concept representation of 61 Countesses Ave (Hart, 2013).....	73
<b>Figure 5.2</b> - Temporary container village (Keuler, 2013).....	73
<b>Figure 5.3</b> - Cost Distribution of Conventional Control Case.....	79
<b>Figure 5.4</b> - Cost Distribution of Single-storey Test Case 1. ....	80
<b>Figure 5.5</b> - Cost Distribution of Multi-storey Test Case 2.....	81
<b>Figure 6.1</b> - Maslow's Hierarchy of human needs.....	88
<b>Figure 6.2</b> - Relationships between Human Needs, Human Norms and Human Preferences regarding housing. ....	91
<b>Figure 6.3</b> - The preferences of the respondents, according to the visual impact of each home. .....	102
<b>Figure 6.4</b> - The preferences of the respondents, according to the spatial, heat retention, waterproofing and soundproofing attributes of each home. ....	104
<b>Figure 6.5</b> - The preferences of the respondents, according to the fire risk, security, durability, rigidity and workmanship.....	105
<b>Figure 6.6</b> - The preferences of the respondents, according to the fastest construction time, modularity benefit, inside and outside appearance.....	106
<b>Figure 6.7</b> - The preferences of the respondents, according to the visual impact of each home. This was the result after being presented with perfect information. ....	107
<b>Figure 6.8</b> - The preferences of the respondents, according to the physical attributes of each home. This was the result after each respondent was presented with perfect information. ....	107
<b>Figure 6.9</b> - The willingness of the respondent to stay in an ISBU house if it resembled a conventional house. ....	108
<b>Figure 7.1</b> - Carbon footprint of conventional house design (Brewis, 2013). ....	114
<b>Figure 7.2</b> - Acidification potential of conventional house design (Brewis, 2013). ....	115
<b>Figure 7.3</b> - Resource depletion of conventional house design (Brewis, 2013).....	115

<b>Figure 7.4</b> - Waste generation of conventional house design (Brewis, 2013).....	116
<b>Figure 7.5</b> - Carbon footprint of ISBU single-storey house design. ....	118
<b>Figure 7.6</b> - Acidification potential of ISBU single-storey house design. ....	118
<b>Figure 7.7</b> - Resource depletion of ISBU single-storey house design. ....	119
<b>Figure 7.8</b> - Waste generation of ISBU single-storey house design.....	120
<b>Figure 7.9</b> - Environmental Impact Index of both cases. ....	121

## LIST OF TABLES

<b>Table 2.1</b> - Finance-linked Individual Subsidy Programme Breakdown.....	21
<b>Table 4.1</b> - Properties of COR-TEN Steel.....	60
<b>Table 5.1</b> - Annual Container Capacity of SA Ports.....	77
<b>Table 5.2</b> - Summarised cost for each case.....	84
<b>Table 6.1</b> - Age distribution of respondents.....	97
<b>Table 6.2</b> - Population distribution of respondents.....	98
<b>Table 6.3</b> - Religious distribution of respondents.....	98
<b>Table 6.4</b> - Marital status distribution of respondents.....	98
<b>Table 6.5</b> - Number of children per household.....	99
<b>Table 6.6</b> - Number of other family living with household.....	99
<b>Table 6.7</b> - Number of friends living with household.....	99
<b>Table 6.8</b> - Education level of respondents.....	100
<b>Table 6.9</b> - Work status of respondents.....	100
<b>Table 6.10</b> - Income level per month of respondents.....	100
<b>Table 6.11</b> - Housing types distribution.....	101
<b>Table 6.12</b> - Mode of travel to work for respondents.....	101
<b>Table 7.1</b> - EDIP Normalisation and weighting factors.....	113
<b>Table 7.2</b> - Summary of total environmental impact of conventional house design.....	116
<b>Table 7.3</b> - Summary of total environmental impact of ISBU single-storey house design.....	120
<b>Table 7.4</b> - Normalised and weighted Environmental Impact values.....	121

## LIST OF EQUATIONS

<b>Equation (6.1)</b> - Sample Size For Proportions.....	96
<b>Equation (6.2)</b> - Finite Population Correction For Proportions.....	96
<b>Equation (7.1)</b> - Carbon Footprint.....	111
<b>Equation (7.2)</b> - Acidification Potential.....	111
<b>Equation (7.3)</b> - Resource Depletion.....	111
<b>Equation (7.4)</b> - Production Waste.....	111
<b>Equation (7.5)</b> - Apparent Constructed Volume, $VAC_i$ .....	112
<b>Equation (7.6)</b> - Apparent Wreckage Waste Volume, $VAR_i$ .....	112
<b>Equation (7.7)</b> - Apparent Packaging Waste Volume, $VAE_j$ .....	112
<b>Equation (7.8)</b> - Waste Generation.....	112

## LIST OF ABBREVIATIONS

ABT	Alternative Building Technology
BNG	“Breaking New Ground” housing policy
DHS	Department of Human Settlements
ECSA	Engineering Council of South Africa
EI	Environmental Impact
EDIP	Environmental Design of Industrial Products
EPS	Expanded Polystyrene
FEA	Finite Element Analysis
FEM	Finite Element Modelling
HDA	Housing Development Agency
IDP	Integrated Development Plan
IRDP	Integrated Residential Development Programme
ISBU	Intermodal Steel Building Unit
LCA	Life Cycle Assessment
LCIA	Life Cycle Impact Assessment
LSFB	Light Steel Frame Building
NHBRC	National Home Builders’ Registration Council
PHP	People’s Housing Process
RDP	“Reconstruction and Development Programme” housing policy
SABS	South African Bureau of Standards
SANS	South African National Standards
TEU	Twenty-foot Equivalent

# CHAPTER 1

## INTRODUCTION

### 1.1 Background

Section 26 of the Constitution of South Africa states that all South Africans should have the basic right of access to adequate housing. This responsibility of housing the people of South Africa falls to the state (Currie & De Waal, 2005), which is empowered to utilize all legislative and economic resources at its disposal in order to achieve this right to housing in all forms. Although the state has mobilised resources and labour after 1994 to achieve these objectives, many challenges remain in the facilitation and provision of adequate subsidised and social housing (Khaki, 2009).

The backlog of cost effective and high quality housing units continues to grow at a rapid pace. Although the proportion of poor households living in formal dwellings increased from 47% in 1994 to 66% in 2012 (Affordable Housing Development South Africa, 2012), the population also expanded from 40.6 million to 51.8 million from 1996 to end-2011 (Statistics South Africa, 2012). The Department of Human Settlements reported the social housing backlog reaching 2.3 million units in 2009 (South African Department of Performance Monitoring and Evaluation, 2012) which is a slight decrease from the reported 2.4 million in 2007 (Sisulu, 2007), yet a significant increase over the 1.8 million units reported in 2001, and the 1.5 million units reported in 1996 (Sapa-AFP, 2006). Cape Town alone has an approximate housing backlog of 362 575 households as of March 2013 (Western Cape Government Provincial Treasury, 2013), and has been one of the largest housing backlogs in South Africa since 2009 (Tredoux, 2009). These households thus revert to informal dwellings (i.e. shacks) to sustain their needs.

The reasons for the spiralling backlog growth are numerous. The steady annual population rise of 1%, (as well as a 3% increase per year in household numbers due to household size reduction) together with rapid urbanisation, has led to the substantial growth of informal settlements since 1994 (South African Department of Performance Monitoring and Evaluation, 2012). Despite the efforts of the state and considerable monetary investment in the built environment, it has been unable to alleviate this problem. Additionally a sustainable, affordable housing market has not yet come to the fore, due to the lack of product availability, limitations of land and infrastructure as well as procurement and approval delays. The enormity of South

Africa's challenge is thus clear, as the current plan to eliminate the housing backlog is proving ineffective.

When comparing traditional construction to alternative building technologies, Tokyo Sexwale commented in September 2010 that of the 1.5 million houses constructed since 1994, only 17 000 units was built utilising alternative forms of construction (Sexwale, September 2010). This accounts for 0.68% of all constructed houses in the formal housing supply, and clearly indicates that alternative technologies and building methods are not contributing significantly to the national housing infrastructure supply.

## 1.2 Problem Statement

According to Tonkin, five challenges inhibit a decrease in the housing backlog (Tonkin, 2008):

- 1) The lack of affordable, well-placed land relegates communities to weakly integrated settlements;
- 2) Slow funding response from government, as well as under-spending their budgets;
- 3) Subsidies allocated are increasing at a rapid pace;
- 4) Insufficient capacity of the housing sector that can "pull" households with housing affordability out of the subsidised, "gap market" group and into better quality housing;
- 5) The withdrawal of large construction groups, after the announcement in 2002 that local authorities will handle the development of low-income housing projects.

Thus, the primary challenges facing housing relate to financial, political and societal issues. Due to the many spheres of influence affecting the delivery of housing, one can deduce that there is no single sure-fire way to address all issues directly.

Instead of focusing on forcing a single solution for housing delivery (i.e. the conventional single unit brick and mortar home), it may prove beneficial to research an alternative technical means to address the different challenges facing housing delivery, simultaneously. This research study aims to investigate the feasibility of using shipping container-based alternative building technologies locally, similar to how it is utilised for low-cost and affordable housing in the international built environment.

## 1.3 Research Statement

The main research question for the study is as follows:

*"How is the use of Intermodal Freight Containers a better alternative to conventional construction in low-cost subsidised and gap market homes in South Africa?"*

In order to investigate this quantitatively, it is necessary to break it up into measurable parameters. By using the definition of sustainability as a framework, the research statement is split into three different sub-parameters: an economic parameter (relating to price, construction time, quality and supply), a societal parameter (relating to social acceptability and labour use) and an environmental parameter (relating to life cycle emissions, waste production and resource depletion). The main research statement is thus expanded into three sub-questions, as listed below:

- 1) “Can housing units be produced at lower cost, in less time and at high quality?”
- 2) “Will this alternative building technology be accepted or rejected by beneficiaries?”
- 3) “Is it the greener/environmentally-friendlier option?”

Each question will need to be tested and compared to show if the main statement is correct or not. A brief review and description of each parameter is given in the respective chapters.

## **1.4 Research Methodology**

The study aims to answer whether shipping containers can sustainably be used in housing projects instead of conventional homes. To achieve this the study first researches the housing situation of South Africa to define the central challenges that inhibit the decrease in the formal housing backlog. After the challenges are identified, the possibility of using containers is investigated.

Container-based residential projects are scarce in South Africa, and thus there is insufficient data for building a feasibility comparison solely out of case studies. Due to this factor, it is necessary to design two test cases based on container housing: the first test case relates to a single-storey, low-density house consisting of containers and the second test case relates to multi-storey, medium-density housing consisting of containers. The single-storey home will provide a reliable comparison with the conventional homes in the housing supply, while the medium-density design will provide insight into the feasibility of containers in high-density residential projects.

These two test cases are then compared to equivalent, conventional building solutions in terms of price, rate of construction, social acceptance and environmental impact. This comparison will then yield a feasibility matrix of using containers in local low-cost housing projects. The methodology followed the research objectives. Section 1.5 gives a description of the research objectives. The reader is referred to section 1.5 for additional information to the methodology described here.



## 1.5 Objectives of the Study

The primary objective of this study is to research whether it is feasible to consider containers as “building blocks” in government-assisted housing, instead of conventional construction. If it is indeed feasible, it will utilise the advantages of constructing container housing (i.e. faster erection times) and thus negate some of the challenges facing the housing backlog in South Africa. This primary goal is divided into the following objectives:

- Understand the current housing situation in South Africa and determine the challenges facing housing delivery;
- Investigate the international use of containers in affordable housing and develop a solution that meets the requirements of stakeholders and regulations and addresses the challenges;
- Compare this container solution with a counter-performance conventional solution in terms of cost, time and product quality;
- Determine the social acceptability of this container solution by means of public participation;
- Determine if the container solution is more environmentally friendly than using masonry housing solutions;
- Finally, deliver a feasibility assessment on the use of containers as building blocks for subsidised and gap housing in South Africa.

## 1.6 Chapter Overview

The following chapter overview contains a brief summary of each section of the thesis.

### Chapter 1 - Introduction

This chapter serves as an introduction to the research study. It outlines the problem statement as determined through the literature review, as well as a research statement outlining a solution. The research methodology as well as the thesis objectives are defined. A summary of the contents of each chapter ends the introduction.

### Chapter 2 - Literature Review on Affordable Housing

Chapter 2 contains the literature review that documents the background of housing in South Africa, as well as the surge in modern container building architecture and construction, which can prove to be feasible in accelerating housing delivery.

**Chapter 3 - Research Design and Methodology**

Chapter 3 discusses the underlying quantitative research approach that was used in the study. The expansion of the original research statement into three different, measurable parameters is discussed, as well as the necessity of multiple test case designs due to varying residential densities. The primary research instruments are also investigated. Finally, the limitations and ethical considerations of the study are given and the chapter ends with a conclusion.

**Chapter 4 - ISBU Test Case Requirements and Design**

Chapter 4 details the concept design requirements, concept design itself and testing of the two container-based test case solutions according to the SANS codes of practice. It also provides additional information on two equivalent, conventional solutions (based on real-world data) that will be used to compare the economic, societal and environmental parameters.

**Chapter 5 - Cost, Time and Quality Assurance Analysis of ISBU Housing**

Chapter 5 considers the first parameter, namely all factors that affect the economic sustainability of a project. These consist of the price per square meter of each test case, the construction time and the final quality, as compared to conventional solutions. The chapter provides an estimate to the final cost and construction time of the different solutions, as well as a short discussion on quality assurance and container supply.

**Chapter 6 - Social Acceptance of ISBU Housing**

Chapter 6 details the social acceptability of a container-based solution by means of a comprehensive face-to-face social survey that was carried out in an informal settlement. Only the single-storey test case solution was compared to its conventional counterpart, as the medium-density case did not apply due to the rural nature of the informal settlement. The chapter details the results of the survey and ends with an interpretation and discussion of the findings.

**Chapter 7 - Environmental Impact of ISBU Housing**

Chapter 7 investigates the environmental impact of the ISBU solutions versus the conventional solution. This chapter is based on a previous study regarding the environmental impact of alternative building technologies in South Africa, and makes extensive use of existing quantification models. The results are then discussed and the chapter concluded.

**Chapter 8 - Discussion, Recommendations and Conclusion**

Chapter 8 provides the feasibility assessment of using containers versus using conventional methods of construction. Research recommendations are made regarding further investigation into specific ISBU construction and the research report ends with a final conclusion.

## CHAPTER 2

# LITERATURE REVIEW ON AFFORDABLE HOUSING IN SOUTH AFRICA AND ISBU ALTERNATIVES

### 2.1 Introduction

The backlog of low-cost, good quality and suitably located housing units in South Africa is not decreasing fast enough. The social housing backlog, which forms a subset of the overall low-cost housing backlog, was estimated at over 2.3 million units in 2009 but for many complex reasons this backlog is resisting decline. This is despite the fact that the rate of housing delivery remains unparalleled internationally due to the actions of the state and other role-players in the built environment (Rust, 2006).

This chapter provides the background to the housing crisis currently facing millions of South African households, as well as a review of a possible solution in the form of Intermodal Steel Building Units (ISBUs), which may help alleviate the backlog.

The first section of the literature study reviews the current housing situation of the country. To understand the complexities that accompany the housing crisis one must examine the country's history concerning housing, from pre-colonial times to the current, post-apartheid democracy. This provides the backdrop to, and justification of, the housing policies that were enacted after 1994. The resulting challenges and housing backlog are also discussed from the viewpoints of the stakeholders in the low-cost housing sector. A comparison of several implemented and proposed alternative construction solutions follows, with a summarised problem definition concluding the first section.

The second section of this chapter investigates one of the possible alternative construction solutions from the first section. The use of repurposed shipping containers for low-cost homes, known as ISBUs, are mentioned specifically. This section starts with the history of the shipping container as well as the birth of modern container architecture. An overview of the different uses of shipping containers follows, with specific emphasis on containers as residential building modules. The advantages and drawbacks for utilising a container in this manner are also given, and a discussion on the realistic feasibility of an alternative low-cost housing solution ends the chapter.

## 2.2 The Context of Low-Cost Housing in South Africa

The current task of housing the people of South Africa is the responsibility of the state, which is empowered to utilize all legislative and economic resources at its disposal, in order to achieve this right to housing in all forms. Together with the enactment of the “Reconstruction and Development Programme” (RDP), the state paved the way to providing access to subsidised low-cost housing and helped form the entry-level housing market in South Africa after 1994. The additional expansion of housing policy by means of the “Breaking New Ground” plan (BNG) then shifted focus to the development of sustainable and integrated communities as opposed to only core house structures.

Although the state has implemented these policies and mobilised resources and labour to achieve these objectives, many challenges still remain in the facilitation and provision of adequate, low-cost housing and the eradication of the housing backlog (Khaki, 2009).

### 2.2.1 History of Housing in South Africa

The injustices regarding equality has plagued South Africa since the inception of the Cape Colony, and have contributed to the sprawling economic and societal problems that face the present generation of residents. This section briefly outlines the history of South Africa, in the context of housing.

#### 2.2.1.1 Colonial Era (1700 - 1948)

According to the local laws as enforced by the Dutch settlers in the Cape during the late-1800's, persons of colour were not allowed to own land (Wyk, 1999). This restriction was amended after the advent of mining in the cities, and the creation of “black” locations were legalised by several pieces of legislation to enable the use of cheap black labour. This formed the precursor to the Urban Areas Act (1923) and the infamous Group Areas Act (from 1950), that was governed and enforced by the Native Affairs Department. These acts were later incorporated into the apartheid legislation in 1952.

The justification behind these acts were that cities were seen as “the natural properties of whites due to the rationalism that urban areas were built by white colonists on land that was transferred to them through peaceful negotiations with local black tribes” (Smith, 2010).

#### 2.2.1.2 Apartheid Era (1948 - 1994)

From the first official apartheid law enacted in 1950, the living areas of South Africa were segregated into different regions for people of different ethnicities. The set of apartheid laws

aimed to centralise white communities into low-, medium- and high-density areas surrounding the central business districts of main cities, with non-white communities located at the edges of cities. These communities were severely restricted in terms of economic growth and social development, and deprived of the basic rights to housing, shelter and security that the white communities enjoyed.

As thoroughly summarised by Smith and Williams, the housing principles of cities under apartheid rule were as follows:

- 1) All cities and towns must have a corresponding non-white township;
- 2) These townships must be large enough to sustain the community, and allow for expansion without spilling over into another racial group area;
- 3) Townships must be located an adequate distance away from white areas;
- 4) Industrial areas are required to act as buffer zones between non-white and white racial areas;
- 5) Access to the city from non-white areas should be easy, and preferably by rail;
- 6) Access from any racial group area to industrial areas should be situated so as to avoid any contact between differing racial groups, or allow trespassing by one racial group over another's territory;
- 7) The buffer zones should be of adequate size, determined by the residential density of the neighbouring white areas;
- 8) Townships must be located away from national roads, and the residents discouraged from utilising these roads for transport;
- 9) All communities not situated in the designated zones must be relocated;
- 10) Servants and labourers must be available to the white community, but their residential location cannot be near white suburbs. (Smith, 2010) (Williams, 2000).

(Annexure A contains a visual representation of racial distribution data in Cape Town and Johannesburg, according to the 2011 census).

During the late stages of apartheid in the 1980's, South Africa experienced a major shortage in housing near the cities as apartheid urban planning curtailed development. This led to the creation of the National Housing Forum (NHF) in 1992 that aimed to develop a plan to mitigate and remove the damage caused by the ethnic-based housing policies of the apartheid state (Newton, 2008). During this period the NHF deliberated on the type of housing approach that it should follow in the future: near-adequate housing for as many people as possible, or standardised 4-bedroom units with a higher standard of living for families (Newton, 2008).

According to Smith, the latter option was chosen and forms the basis of the state housing policy to the present day.

Additionally, the ANC advocated a strategy of making the country ungovernable by not paying taxes and withholding required rates by residents. This resulted in millions of people working together by withholding payment, and placed pressure on the state to act on a reform. After 1994 the ANC-led government created the “Masakhane” strategy, to encourage people to pay their rates and taxes again (McDonald, 2002).

### **2.2.1.3 Post-apartheid Democratic Era (1994 - 2013)**

The end of apartheid brought about the realisation of the large socio-economic issues that plague the housing backlog to this day. To eradicate the apartheid-era of city planning the ANC developed the Reconstruction and Development Plan that aimed to undo the damage done by past segregation. This served as the party’s election manifesto and the housing aspect was considered important in terms of spurring economic growth and development. Afterwards, many projects that followed the ideals of the RDP were successful, but the lack of an integrated development plan resulted in contradictory development initiatives between municipalities (Pieterse, 2004). This led to the creation of the necessary housing framework, policies and thus an integrated, national housing strategy.

## **2.2.2 Housing Framework, Policies, Regulatory Authorities and Subsidy-Based Assistance Programmes**

To formulate a technical solution to address the housing backlog, one must understand the housing sector of South Africa, and thus the underlying policies and regulations related to the subsidy housing system as used by the state. According to the Department of Human Settlements, several different policies and regulations have been developed since 1994, when South Africa transitioned to a democratic republic. This was done with the help of several stakeholders in the built environment. These stakeholders can be divided into the following groups:

- Government departments - human settlements, public works, and land and rural development;
- Public and private property developers;
- Finance - retail banks, funds and private equity;
- NGOs involved in housing delivery;
- Construction and Engineering firms;
- Material suppliers;

- Homeowners and residents.

The collection of developed policies determine the national housing policy framework, and provide the housing policy development implementation as followed by the state. The most important pieces of legislation that pertains to housing are as follows (Department of Human Settlements, 2009):

- The Constitution of the Republic of South Africa Act, 1996;
- The Housing Act, 1997;
- The Public Finance Management Act, 1999;
- The Municipal Finance Management Act, 2003;
- The Division of Revenue Act, 2003;
- The Growth, Employment and Redistribution Strategy (GEAR), 1996;
- The Reconstruction and Development Programme (RDP);
- The Accelerated and Shared Growth Initiative in South Africa (ASGI-SA);
- The White Paper, and local government frameworks pertaining to public service.

Tonkin notes that one should not only consider the legal aspects of housing. He describes the housing problem of South Africa as broad based and multi-faceted, with significant influences arising from the stakeholders in the political and societal spheres of the country (Tonkin, 2008). This does not mean that one should ignore the legal aspect; one must rather consider it in cognisance of the larger issue at hand, and not merely on its own merit. The housing legislation has been adapted and additional acts created by the state since 1994 based on this principle, to better fulfil the needs of the residents of the country.

The Constitution of South Africa, the New Housing Policy of 1994 (RDP) and the Comprehensive Plan for the Development of Sustainable Human Settlements of 2004 (BNG) will be discussed briefly, as they determine the viability of the technical solution put forth in this study.

### **2.2.2.1 South African Constitution (1996)**

According to the Constitution of South Africa, all residents of the country have the right of “access to adequate housing, and makes it incumbent upon the State to take reasonable legislative and other measures within its available resources to achieve the progressive realization of this right” (Department of Human Settlements, 2009). This statement forms the constitutional basis of all other housing acts and policies.



### **2.2.2.2 The New Housing Policy and Strategy for South Africa - according to the "Reconstruction and Development Programme" (1994)**

The Reconstruction and Development Programme, abbreviated and commonly known as "RDP" in the housing sector, has become synonymous with low-cost government subsidised housing in South Africa. After the advent of democracy in the country, the "New Housing Policy" White Paper was published according to the RDP strategy in 1994, as a means to eradicate the drastic need for housing in post-apartheid South Africa. An estimated 88% of all households received an income of less than R3 500 per month in December 1994, and thus most households would need assistance by means of financial subsidies to enter the housing market (Rust, 2006).

This housing policy states that all South Africans must have access to "a permanent residential structure with secure tenure, ensuring privacy and providing adequate protection against the elements." In addition, "potable water, adequate sanitary facilities including waste disposal and domestic electricity supply" must be provided by the state (Department of Housing, 1994). The careful consideration of the special needs of youth, disabled, aged and single parent families are another factor. To achieve this, the policy embraces eight key strategies:

- 1) *Stabilising the housing environment.* Pursuing an incentive based approach to private investment in low-income housing projects;
- 2) *Supporting the housing process.* Meeting the basic needs of households by promoting a wide variety of housing delivery approaches to ensure access to well-located land, basic services, secure tenure and on-going construction and upgrading of the public environment;
- 3) *Mobilising housing credit (short- and long-term).* Providing accessible credit to those households that can afford it and thus gaining a valuable, positive credit record;
- 4) *Mobilising savings.* Utilising personal savings for credit leverage;
- 5) *Subsidy assistance.* Using a flexible, capital subsidy approach to empower those caught in the lower end of the housing market;
- 6) *Institutional capacity arrangements.* Housing will gain priority attention from government through the institution of a statutory and parastatal framework;
- 7) *Land facilitation.* Facilitating the speedy release and servicing of public land;
- 8) *Coordinated government investment in development.* Providing all stakeholders in the public and private sectors with an integrated mechanism at provincial and local government level, to coordinate their actions (Department of Human Settlements, 1994).

The housing policy framework enabled the provision of a single 30m<sup>2</sup> house on a 250m<sup>2</sup> plot of land to eligible beneficiaries. To qualify for this subsidy, each beneficiary would need to have an income of less than R3 500 per month, and may not have owned a house previously. This subsidy was attainable through large-scale housing projects, flat-based renting of homes or funding to self-build a house by means of the Enhanced People's Housing Process (EHP) or the Integrated Residential Development Programme (IRDP). (Rust, 2006)

An estimated R36 000 formed the budget for the core top structure of each housing unit, with each family earning less than R1 500 per month being eligible for free housing. The higher income bracket of R1 501 to R3 500 required applicants to contribute R2 479, and then access to a subsidy value of R34 000 (the intention behind this subsidy split was a better quality and larger house for the top bracket of the population by utilising their access to additional credit from financial institutions).

The policy also advocated the use of 5% of the total government expenditure on newly created houses, to achieve a minimum of 350 000 units delivered per year (Department of Housing, 1994). This has not realised however, as government decreased the annual expenditure to 2% to decrease the financial deficit facing the state in 1994 (Tonkin, 2008).

The state implemented several instruments to achieve the goals as set out by the original act, as well as the additional acts that came into being before 2004. They are:

- 1) Incremental housing;
- 2) Social housing;
- 3) Rural housing;
- 4) Financial services;
- 5) Municipal capacity building interventions;
- 6) Housing sector strategies through the use of Integrated Development Plan's (IDP's) (Rust, 2006).

### **2.2.2.3 The Comprehensive Plan for the Development of Sustainable Human Settlements - "Breaking New Ground" (2004)**

Popularly known as the "Breaking New Ground" policy, the "Comprehensive Plan for the Development of Sustainable Human Settlements" was enacted in 2004. This policy aimed to shift the delivery emphasis of low-cost housing from primarily core RDP houses to integrated and sustainable communities. In order to improve the quality of life for future beneficiaries, the policy advocated an increase in house floor area from 30m<sup>2</sup> to 40m<sup>2</sup>, to accommodate a higher

standard of living. Additionally the policy complied with the United Nations' Millennium Development Goals. The primary ends of the BNG policy are:

- 1) *Sustainable Human Settlements*, by ensuring the balance of economic growth and social development by monitoring the carrying capacity of well-managed settlements;
- 2) *Integration*, by shifting the housing focus from core housing units to the creation of sustainable human settlements;
- 3) *Housing as assets*, by providing property as a tool for wealth creation and empowerment to beneficiaries; and
- 4) *Upgraded Informal Settlements*, by integrating current informal settlements into the broader urban fabric of South Africa (Rust, 2006).

To achieve these goals, the state defined additional instruments to provide the means. These are:

- 1) *Reduction of Administrative Overhead*, by means of accreditation so that funding for projects can flow directly and so reduce unnecessary costs;
- 2) *Coordinated and Effective Inter-governmental Relations*, by means of enhanced integrated planning frameworks and bilateral cooperation between stakeholders;
- 3) *Demand-driven Delivery*, by enabling the state to determine the location and nature of housing, prioritising projects severely in need and tailoring each project to the needs of the communities by adopting a flexible approach;
- 4) *Effectively Functioning Housing Markets*, by addressing and helping the "gap" housing market and enhancing the roles of the private sector (Rust, 2006).

The BNG policy did not aim to replace the goals as set out in the RDP and National Housing Policy, but rather expanded the housing roles of the municipalities.

By 2013, the amount of subsidy allocation available for the top structure of a 40m<sup>2</sup> housing unit (as prescribed by the BNG policy and the NHBRC) stands at R65 000. Additional funding is allowed for project-specific geo-technical work, Southern Cape Condensation mitigation measures (which only applies to the south coast), utility services and several other possible municipal and urban grants extending to a total of R102 000 (Keuler, 2013). The Department of Human Settlements estimated that each housing unit cost R135 000 to build in 2009, taking into account escalation and the high amount of project rework (FinMark Trust, 2009).

#### **2.2.2.4 Building Regulations - South African National Standards**

The standardisations of building practices are crucial to ensure acceptable quality, health and safety of the built environment. Referred to as the codes of practice issued by the South African Bureau of Standards (SABS), these sets of building regulations aimed to provide rules and guidelines for the design, construction and quality of civil works and housing in the South African built environment. There is also an on-going process to update the previously used SABS codes to revised South African National Standards (SANS), which are based on several international codes e.g. the British codes.

#### **2.2.2.5 National Home Builders Registration Council**

In order to ensure a high level of quality among homebuilders, the National Home Builders Registration Council was created in 1995 as an entity that served the state. All home builders in the country are required by law to register with this council, in order to provide protection for the beneficiaries and consumers of houses. A Code of Conduct for Home Builders came into effect in March 2007 and aims to stop corrupt and inept builders from inundating the market with inferior quality houses by providing ethical and technical standards that must be adhered to (Brewis, 2012).

The council also runs a so-called Product Defect Warranty Scheme, which aims to pay for repairs of defects when homeowners make a claim. This scheme is funded primarily by the registration fees required from members, and is valid for five years after the completion of the structure (Tonkin, 2008).

Additionally, the NHBRC also acts as arbitrator during disputes between the builder and home owner, if major defects occur on the constructed building after hand-over (Brewis, 2012).

#### **2.2.2.6 Housing Development Agency**

The Housing Development Agency (HDA) was established by Act 23 of Parliament in 2008 with the intention of creating a vehicle that will aid in the sustainable development of housing and human settlements, and thus the creation of positive societal and economic growth in those communities that benefits thereof.

The functions of the agency, as set out in Section 7 of Act 23, are as follows (Housing Development Agency, 2008):

- Develop plans and strategies for identification and acquisition of suitable land for residential- and community-development;

- Provide project management services to organs of state regarding the development and releasing of private or communal land, fit for residential use and community development;
- Ensure sustainability, compliance and optimised job creation with residential and community development.

All these activities must also be approved directly by the Minister of Human Settlements, to which the board of the HDA must report.

### **2.2.2.7 Housing Subsidy Programmes**

The Department of Human Settlements provides the following subsidies related to housing (Education Training Unit NGO, 2007), (Department of Human Settlements, 2011).

- *Consolidation Subsidy Programme*, for people who have received a subsidy for a serviced property, and who wishes to build a core top structure;
- *Individual Subsidy Programme*, for individuals who want to buy a house for the first time. This subsidy may only be applied for once;
- *Integrated Residential Development Programme*, which is similar to a project-linked subsidy. This is paid out to the developer granted that it is compliant with the Social Compact Agreement agreed-upon by the community, the local authority and the developer;
- *Institutional Subsidy Programme*, for non-profit organisations that want to buy, repair, build and then rent flats or houses.
- *Enhanced Extended Discount Benefit programme*, for households that make use of publicly-owned rental housing, and want to buy the property at a discounted selling price;
- *Rural Subsidy Programme*, for people that don't have formal authorisation or tenure rights on the land that they live on;
- *Enhanced People's Housing Process*, for people that want to build their own homes;
- *Farm Resident Housing Assistance Programme*, where farm workers and occupiers work together with the farm owner to provide acceptable housing;
- *Finance-Linked Individual Subsidy Programme (FLISP)*, which helps individuals to obtain financial assistance if they earn between R3 500 and R15 000 per month (thus falling into the so-called 'gap market').

Several minimum prerequisites apply for initial qualification of these subsidies, These include (Department of Human Settlements, 2011):

- 1) Citizenship of beneficiary;
- 2) Competent to mutual agreement, i.e. to sign a contract;
- 3) Not previously applied for state funding;

4) First time property owner.

Additional general requirements must also be satisfied, but their impact falls outside the scope of the technical nature of this thesis.

### **2.2.3 Current Challenges to Effective Housing Delivery**

Since the inception of the Reconstruction and Development Programme in 1994, immense progress has been made on housing for the poor: the proportion of poor households living in formal dwellings increased from 47% in 1994, to 56% in 2009, and 66% in 2012, and this serves as proof of the success of the programme (Affordable Housing Development South Africa, 2012). Yet the enormous scale of the remaining challenge is nonetheless clear, with 34% of all residents still utilising informal housing for meeting their basic needs.

According to Sisulu in 2007, the delivery of housing units in South Africa to those in need remained unparalleled internationally in terms of rate of delivery, with an equilibrium of provided housing versus needed housing (also known as the “backlog barrier”) being breached in 2007 with 2.4 million units. She announced in her speech at the 2007/2008 budget vote that “this is the first time in our history that our backlog has been less than the number of houses produced. Put differently, we have housed more people than those needing houses” (Sisulu, 2007).

It should be noted by the reader that the housing backlog count was not accurately calculated by the Department of Housing before 2001, as these figures only accounted for people living in high-density urban areas. This can be seen in the huge discrepancy between the 1.5 million units that were reported in 1996 (Sapa-AFP, 2006), the 1.8 million units reported in 2000 and the 2.78 million reported in 2001. It was only after 2001 that the Department included the counts for people living in informal, rural settlements (Khaki, 2009).

The Department of Human Settlements reported the social housing backlog reaching 2.3 million units in 2009 (South African Department of Performance Monitoring and Evaluation, 2012). This is a slight decrease from the reported 2.4 million in 2007 (Sisulu, 2007), and significantly from the 2.78 million reported in 2001 (Khaki, 2009).

Cape Town alone has an approximate housing backlog of 362 575 households as of March 2013 (Western Cape Government Provincial Treasury, 2013), and has been one of the largest housing backlogs in South Africa since 2009 (Tredoux, 2009). These households thus revert to informal dwellings (i.e. shacks) to sustain their needs.

The reasons for the large backlog are numerous. The steady annual population rise of 1%, (as well as a 3% increase per year in household numbers due to a trend in household size reduction) together with rapid urbanisation, has led to the substantial growth of informal settlements since 1994 (South African Department of Performance Monitoring and Evaluation, 2012). Despite the commendable efforts of the state and considerable monetary investment in the built environment, it has been unable to alleviate this problem according to the delivery rate estimates as set forth in the RDP and the BNG policies. This has not resulted in a sustainable, affordable housing market to emerge due to the lack of product availability, limitations of land and infrastructure as well as procurement and approval delays (FinMark Trust, 2009).

A report named the “Public Service Commission Report on the Evaluation of the National Housing Subsidy Scheme” which was published in 2003 outlined the challenges experienced by the built environment regarding housing delivery. From the report, Tonkin summarised the main challenges of housing facing South Africa as follows (Tonkin, 2008):

- 1) The lack of affordable, well-placed land relegates communities to weakly integrated settlements;
- 2) Slow funding response from government, as well as under-spending their budgets;
- 3) Subsidies required and allocated are increasing at a rapid pace;
- 4) Insufficient capacity of the housing sector that can meet the demands of the gap housing market, so as to “pull” households with housing affordability out of the subsidised group and into better quality housing;
- 5) The withdrawal of large development and construction groups, after the announcement in 2002 that local authorities will handle the development of low-income housing projects.

Khaki also notes that the main problems described in the Department of Human Settlements relate to six primary issues, namely subsidies and financing for beneficiaries, affordability of housing, quality of housing, settlement planning and land acquisition (Khaki, 2009).

The following sub-sections investigate the present housing challenges in terms of the six primary issues in terms of the economic, societal and political perspectives.

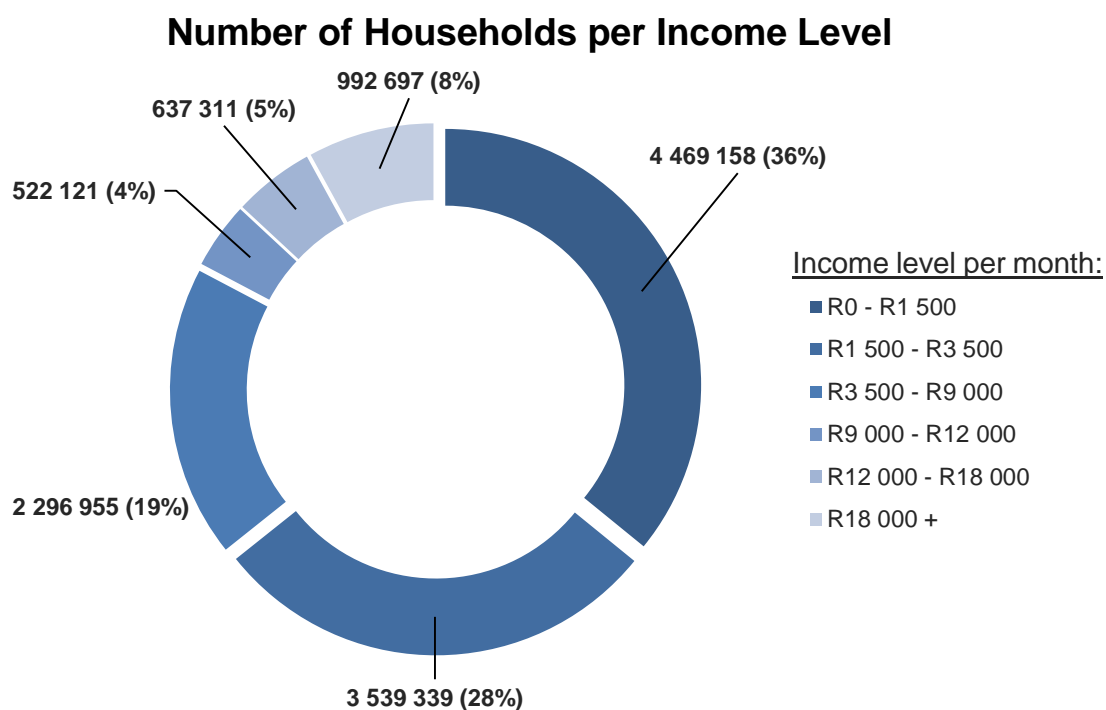
### **2.2.3.1 Subsidies, Financing and the Affordability of Housing**

The low-cost housing sector comprises the lower end of the housing market in South Africa. The current definition of such housing extends to all homeowners earning zero income to a level of up to R18 000 per month (FinMark Trust, 2009). This housing sector is further divided



into two tiers, namely the subsidy-housing sector (lower tier) and the “gap market” (upper tier). The purpose of subsidies and financing for these two sectors are two-fold: first, to provide a system of capital wealth creation that will enable a “trickle-down” of resources for people in the lower tier, and secondly to enable the upper tier to enter into the commercial market (Thring & Kahn, 2003). This goal avoids the utilisation of subsidies *ad infinitum*, but its success is also highly-dependant on the growth of the economy, and thus the growth of the commercial housing market.

See Figure 2.1 for the distribution of households in SA according to their income level as determined by Statistics South Africa for the 2005/2006 fiscal year:



**Figure 2.1** - Household distribution per income level according to the Statistics SA 2005/2006 Income and Expenditure Survey (K. Rust, 2009).

As discussed in sub-section 2.1.2, a homeowner who earns an income between R0 and R3 500 per month can apply for a government subsidised house, with a top structure value of R65 000 as of 2013 (Gronloh, 2013). From Figure 1 the total percentage of households falling into this first category amounts to 64.3%.

The gap market is defined as the range of homeowners with an income level of between R3 500 and R15 000 (Department of Human Settlements, November 2011). Some stakeholders in the built environment extend this definition to an upper limit of R26 000 per month, but this is not widely agreed upon and thus the core definition will be used in this thesis



(Rust, 2006). This category came to be known as the gap market after 1994 due to the ineligibility of beneficiaries to receive a subsidy similar to the homeowners that fall into the sub-R3 500 category, but also unable to access the commercial housing market due to high entry-level of income required for financing. The state has tried to address this barrier via its numerous subsidy programmes. From Figure 1, the percentage of households falling into this second category is 18.5%.

The total percentage of households falling into the subsidised and gap housing market is 82.7%. The Banking Council of South Africa notes that households falling into these categories of housing are unable to utilise adequate financing from banks to improve their quality of living by moving into a higher bracket of housing standard (Tonkin, 2008).

Additionally the Government Communication and Information System reports a total subsidy expenditure of R17.9 billion in the 2013/2014 financial year (Department of Government Communication and Information Systems, 2012). This is a large increase from the expenditure for 2006/2007 which was R5 billion, and from 1996/1997 which was R2.7 billion (Education Training Unit NGO, 2007). This upward trend in subsidy allocation is expected to grow, due to the widespread poverty, income inequality, unemployment, high urbanisation levels and household size reduction (Burgoyne, 2008).

The largest challenge affecting the subsidy programme is the perpetual barrier to the recovering commercial housing market for low-income earners. Rust describes part of the problem as follows:

*“A key contributor to not only persistent but rising inequality in South Africa is the housing market - while our policy regime includes a substantial subsidy providing free housing for the 60% of the population with a household income of less than R3500 (about US\$450) per month, another 20% of the population or so (those earning between R3500 - about R10 000) cannot afford to buy the cheapest newly built house” (Rust, 2006).*

In order to combat this low-income economic barrier in the country, the state has developed several subsidy schemes to help people financially. The most recent initiative (which came into effect on 1 April 2012) known as the revised Finance-Linked Individual Subsidy Programme (FLISP), aims to provide a subsidy amount for beneficiaries in the gap market. This initiative empowers prospective owners to migrate into the more expensive commercial housing market and thus increase the buying and rental stock of homes for the lower bracket of homeowners. This would in turn stimulate the housing market, open up more property for rental and selling, and thus alleviate the backlog. Subsidised programmes would thus enable a housing supply chain, where prospective beneficiaries would be enabled to climb the

property ladder. Note that this subsidy is restricted to homeowners that has a signed Building, or Purchasing Contract with an approved bond from a financial Institution. If the homeowner intends to build the house on his/her own, they must also register with the National Home Builders Registration Council.

FLISP is based on a linearly scaled income-to-subsidy ratio, that ranges from a subsidy amount of R87 000 for a beneficiary earning a monthly income of R3 501, to R10 050 for a beneficiary earning R15 000 per month. Thus, higher salaries will be eligible for smaller subsidy amounts.

For each R100 increment above R3 501, there exists a corresponding subsidy amount. See Table 2.1 for a summary of the applicable subsidy amount for each band of income, in increments of R1 000:

**Table 2.1** - Finance-linked Individual Subsidy Programme Breakdown.

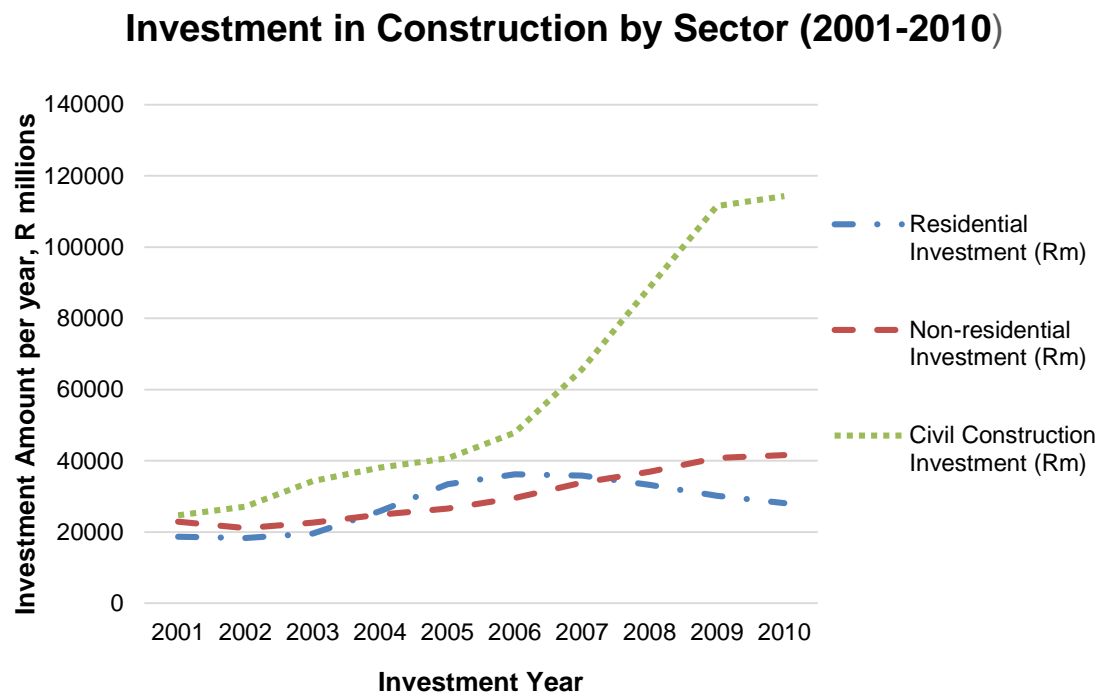
<b>Income Band</b>	<b>Subsidy Amount</b>
R 3 500	R 87 000
R 4 000	R 84 300
R 5 000	R 77 550
R 6 000	R 70 800
R 7 000	R 64 050
R 8 000	R 57 300
R 9 000	R 50 550
R 10 000	R 43 800
R 11 000	R 37 050
R 12 000	R 30 300
R 13 000	R 23 550
R 14 000	R 16 800
R 15 000	R 10 050

(Department of Human Settlements, 3 November 2011.)

This subsidy may be used to buy existing property, to buy a serviced residential stand or for construction of a new residential property. However, the maximum property value that may be financed is R300 000, and an 8 year restriction on the sale of the property applies to the homeowner (National Housing Finance Corporation, 2011). The programme looks feasible in theory, but has been criticised by the industry for failing to sufficiently raise affordability into the commercial market.

The investment in the residential market regarding housing has declined significantly since the global financial crash of 2008. This exacerbates affordability, as the indicative prices of housing are related to the supply and demand of the market. See Figure 2.2 for the annual

investment in residential, non-residential and civil construction in South Africa as reported in the second quarter of 2011:



**Figure 2.2** - Yearly investment in SA construction industry based on market segment, adjusted for 2005 values (Adapted from Industry Insight - The State of SA Construction Industry, June 2011).

The yearly investment in the housing sector has reduced substantially. In conjunction, Melzer reported a large shortage of houses available to people with an income of less than R7 500 per month in 2006. She notes that 2.63 million households falling into the R2 500 - R7 500 income gap could utilise mortgage financing to invest in a better home. This is calculated by taking into account an annual interest rate of 9%, a loan period of 10 years and a repayment value of 25% of the household's income. Thus the maximum amount of credit that the house can access is about R150 000. By adding the applicable FLISP subsidy (which equates to R60 675 for an income of R7 500), the homeowner would have access to R210 675. For an income of R3 500 (based on the above calculation) the homeowner would have access to R137 000 for housing, with the FLISP subsidy contributing R87 000 of the total amount. Melzer says in her report that the total number of houses in the R137 000 - R210 000 range in 2006 consisted of about 1.78 million units, and this results in a shortage of 850 000 houses in the housing sector (Rust, 2006).

Thus, the low-cost housing market is experiencing massive demand, but people are unable to buy into it. This is due to a large shortage of housing development in the sub-R250 000 range.

The Centre for Affordable Housing Finance in Africa has noted that this shortage is due to several factors (FinMark Trust, 2009; Burgoyne, 2008):

- 1) Developers and financiers are wary to offer houses that are functionally equivalent to houses provided with government subsidies, as it is a large risk in terms of loan repayment (which places a 10 to 20 year financial obligation on the buyers) and is in direct competition with “free housing”;
- 2) The estimate of the DHS that each subsidised house costs about R130 000 means that households earning between R3 500 and R5 000 will scarcely be able to afford a house that others get for free;
- 3) The higher building finish quality required of housing in the commercial market make a small house impossible to build for less than R230 000, as opposed to the lower expected quality of subsidised housing;
- 4) Finally, the profit margin (which incorporates the high risk of low-cost housing) will increase the price further, and the affordability gap will widen.

### **2.2.3.2 Quality of Housing**

In an effort to decrease the housing backlog in South Africa, state institutions frequently focus on providing as many houses for as low a cost as possible. Delivery performance is primarily measured in terms of completed units, and this focus on high delivery numbers can lead to projects delivering houses of dubious quality that need to be repaired or even torn down at a later stage (Thring & Kahn, 2003). The previous Minister of Housing, Mr Tokyo Sexwale, noted in August 2012 that the state faced a rework bill of R50 billion due to the construction of poor quality subsidised houses (Business Report, 2012).

The definition of “quality” is quite varied among experts, but usually relates to compliance of predetermined specifications in a project. In terms of successful project management, a “good quality product” is one that is delivered within time, below cost and absent of major defects (Nicholas & Steyn, 2008). It is from this definition that the Triple Constraint Principle of Project Management originates.

This principle dictates that all projects depend upon three intertwined factors: Time, Cost and Quality. For a project to be successful, a balance must be struck between these factors. But an overemphasis on any one or two of these factors will lead to a negative impact on the others. In the case of speedy and cheap housing delivery, it is clear that the overemphasis on time and cost will negatively affect the quality of delivered houses. Much criticism has been raised against the small subsidy value that the state provides for core top structures, as it does not provide a “respectable house of decent size and quality” (Muyeba, 2011).

Several different factors contribute to non-compliance of quality requirements. According to Alink, the primary factors that result in sub-standard quality are insufficient finance, insufficiently trained labour, uncontrolled use of SMME contractors, lack of management expertise and poor workmanship (Alink, 2003).

The quality of a house is determined during the design, construction and operating phases that constitute the lifecycle of a house. A survey conducted by Zunguzane et al. found that beneficiaries experienced a multitude of problems with their subsidised homes that detracted from the overall quality of the house. Some of the problems studied in the survey include (Zunguzane, et al., 2012):

- 1) Accidents or injuries due to defects in the house;
- 2) Leaking water pipes;
- 3) Problems associated with stability;
- 4) Cracks in the walls;
- 5) Inability of the house to resist extreme weather;
- 6) Water penetration through the walls;
- 7) Roof leaks;
- 8) Roofs which make noise or even blow off when windy;
- 9) Incomplete house;
- 10) Dampness;
- 11) Door frames which shake, faulty doors;
- 12) Water penetration through window frames;
- 13) Leaking drains and toilets;
- 14) Collapsing of walls;
- 15) Water penetration through the floor.

Some of these problems can be resolved through proper maintenance of the house (as they will occur normally during the operation phase of the house), but the majority of issues are related to design and construction defects.

### ***2.2.3.3 Integrated Settlement Planning and Lack of Suitable Land***

According to Thring and Kahn, the biggest challenge facing policymakers in South Africa today is the lack of socially- and economically-integrated settlements, developed on well-located land near major metropolitan areas (Thring & Kahn, 2003). This is partly due to the legacy of apartheid, where non-white communities were relegated to the outskirts of major metropolitan areas, with the result that many informal settlements and housing schemes are poorly located today, and often without land tenure (Burgoyne, 2008).

Another obstacle to integrated settlements was the focus of the RDP housing policy, which aimed to provide top core structures to those who resided in informal homes. Thus, the additional development of low-density housing projects after 1994 have contributed to significant urban sprawl in South African cities, which led to the segregated urban form that is prevalent today. In 2004, the BNG policy came into effect and shifted the focus to socially and economically sustainable integrated communities. However, to achieve this objective as set out in the BNG policy, significant urban restructuring is required.

The lack of affordable and suitable land for developing informal settlements is an immense challenge for local government. Due to the high cost of land within cities, it is unfeasible for local government to consider housing projects that are located close to urban centres. For this reason, most developed formal settlements are “mono-functional”, implying that they cannot make use of “economic, social and transport opportunities” (Burgoyne, 2008). This also precludes the development of higher-density housing projects, as they need to be close to supporting urban amenities to experience economic growth (Hart, 2013).

#### **2.2.4 Alternative Building Technologies and the Housing Backlog**

The challenges prohibiting effective housing delivery in South Africa are numerous. The Department of Human Settlements has vowed to address these challenges in the future, with the intention of speeding up the delivery of small houses for people living in informal settlements. However, the majority of housing units in South Africa are built using conventional construction techniques to provide a sturdy, 40m<sup>2</sup> brick and mortar home. This is in stark contrast with other countries, where the use of alternative building technologies provide a stream of innovative solutions for the built environment, and make up a large segment of the affordable housing sector (Slawik, et al., 2010).

The NHBRC provides the following definition for “Alternative Building Technologies”:

*“Innovative housing techniques refer to any deviation from traditional construction methods that are not specified within the limitations of SANS 10400 - it does not necessarily have to be a material that has never been used before”* (NHBRC, 2013). This definition extends to all residential building systems that don’t utilise the standardised method of masonry stacking units. Thus, it encompasses innumerable available products in the international and local market.

However, when comparing conventional construction technologies to Alternative Building Technologies (ABTs), Tokyo Sexwale commented in September 2010 that of the 1.5 million houses constructed between 1994 and 2010, only 17 000 units were built utilising alternative

forms of construction (Sexwale, September 2010). This accounts for 0.68% of all constructed houses in the formal housing supply in 2010, and clearly indicates that alternative technologies and building methods are not contributing significantly to the affordable housing supply of the country.

The following sections look at the different types of available ABT housing systems, technical requirements that these systems must adhere to and the difficulty of large-scale ABT implementation in South Africa

#### **2.2.4.1 Types of Alternative Building Technologies**

The definition of ABTs (according to the Department of Human Settlements) extends to a massive collection of different solution types that can be used to build homes. However, due to the infinite amount of possible solutions available, it is necessary to form a categorised system for a better evaluation.

The end-product requirement for each system is identical, namely a house of good quality, that meets the needs of the beneficiaries. Most systems will follow a reasonably similar path of construction, i.e. site establishment, earthworks, foundations, structural erection, finishing and inspection. For this reason, it is impractical to categorise different systems based on the final product. A better differentiation is found in the erection stage of a house: whether a system is built on-site or prefabricated.

Pre-fabrication aims to shift as much construction time, material and labour to a factory environment. This provides benefits in the form of better quality control, less material wastage, increased production speed and economies of scale, i.e. cost advantages as costs per unit decreases with higher product output. However, decreased local labour, need of skilled labour and increased transport costs negatively affect this type of construction. Flat-pack kit homes, modular systems and manufactured systems fall into this category.

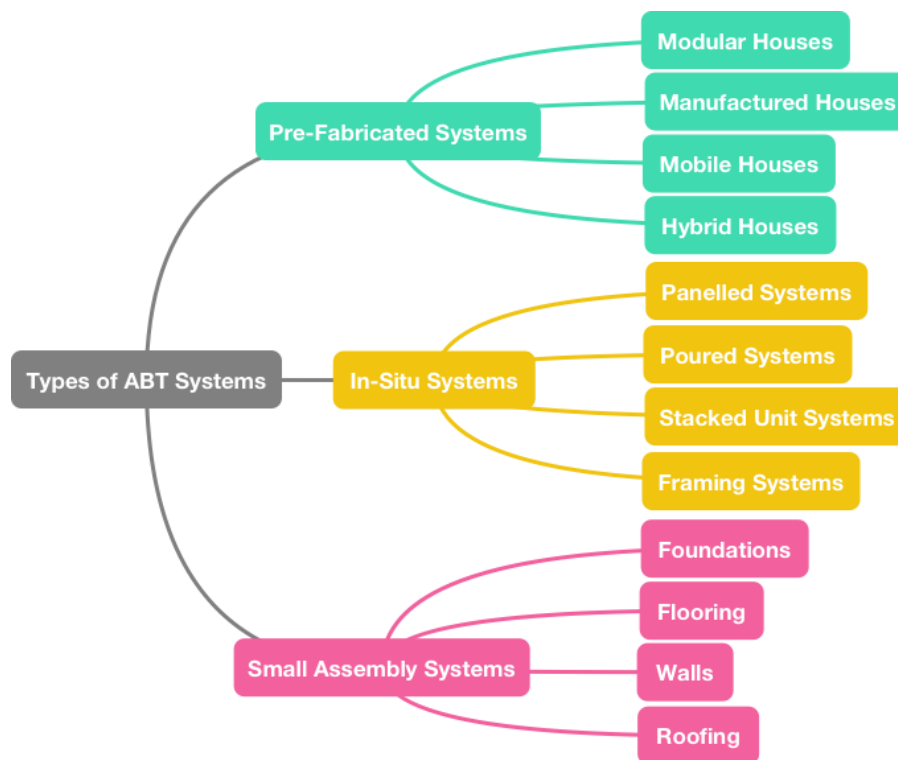
In-situ construction aims to utilise cheaper material costs, on-site local labour and small transport costs to complete large projects. Difficulties in quality assurance and long construction times are a negative for this construction method. Light Steel Frame Buildings (LSFB's), panelled systems, aerated concrete systems, wood framed and concrete masonry systems fall into this category.

Most ABTs differ based on their primary structural components, i.e. load-bearing wall types, framing systems and the foundation types. These form the core top structure of a house. Further minor variations are based on the smaller assembly systems, which differ to a lesser degree between ABTs. These are the flooring (e.g. wooden, concrete, rubberised), wall details



(e.g. insulation, interior finish, exterior finish) and the roofing (e.g. galvanised, tiled, dual-pitch, mono-pitch, flat). There are many minor variations possible on these types of structures regarding layout and materials used, as long as it complies with the required specifications.

From the myriad of available building technologies, a categorised system was developed to incorporate most ABTs available in the housing sector of South Africa (as opposed to housing in the USA, where the availability of cheap wood panel systems present different opportunities). See Figure 2.3 for a compiled layout of the different categories of ABT housing:



**Figure 2.3** - Types of Alternative Building Technology Housing Systems.

Small assembly systems will not be discussed in this chapter, as they are interchangeable for both prefabricated or in-situ construction.

#### **2.2.4.2 Prefabricated ABT Systems**

The prefabricated ABT sector can be divided into four different categories: modular systems, manufactured systems, mobile housing units and hybrid systems (Gronloh, 2013).

- 1) **Modular systems** are complete homes that are built in separate modules, and then shipped to the construction site. The structure is then erected on a finished foundation and the modules are connected. All necessary utilities are installed, and only on-site finishing is required. The life-span of these structures match and even rival those of



conventional structures. The erection speed of a complete house is one day, with a construction lead-time of two weeks for a pre-approved design (Gronloh, 2013). See Figure 2.4 for an example:



**Figure 2.4** - A modular prefabricated home (Fabricated Steel Manufacturing, 2013).

2) **Manufactured houses** are built on a heavy-duty welded steel chassis, and are usually fitted with an expanded polystyrene wall bonded to a hard-wearing interior and exterior wall. These can be made of galvanised sheeting (exterior) and plywood or drywall (interior). Limited maintenance and on-site finishing are required, and the home can be placed on concrete pad footings for a foundation. They are mostly suited for temporary housing (Gronloh, 2013). See Figure 2.5 for an example:



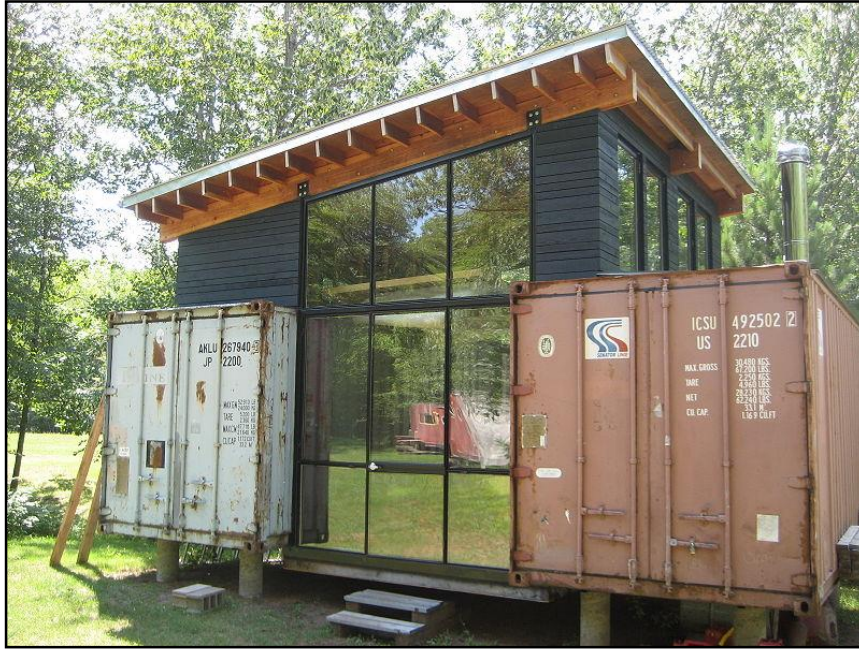
**Figure 2.5** - A manufactured house (Fabricated Steel Manufacturing, 2013).

- 3) **Mobile housing units** are easily-transportable homes built on a wheeled chassis, and are easily transported to different locations. These types of homes are more common in the United States than in South Africa for affordable housing. See Figure 2.6, that shows an unfinished mobile home.



**Figure 2.6** - A mobile home partway under construction (Melton, 2008).

- 4) **Hybrid homes** are a mixed-design type that utilises elements from both the factory-assembled and site-constructed systems. This type of ABT is designed to benefit from the advantages provided by prefabricated designs, as well as those provided by in-situ constructed systems. Construction can be complex, as different design types require an added layer of complexity to construct and this may lead to failure if not properly addressed. Figure 2.7 shows an example of a container-based home used in conjunction with a panelled home design:



**Figure 2.7** - A hybrid home utilising ISBUs as well as a panelled system (RO/LU Design, 2007).

#### **2.2.4.3 In-Situ ABT Systems**

Home design types that utilise on-site construction can be divided into four different categories. These are stacked unit systems, poured systems, framing systems and panelling systems (Zeiber & Zeinor, 2012).

- 1) **Stacked unit systems** consist of concrete bricks that are layered and mortared to create walls. The conventional method of concrete masonry construction falls into this category, although autoclaved aerated concrete bricks are also used. The conventional method for building low-cost houses refers to a traditional 40m<sup>2</sup> brick and mortar structure, with two bedrooms, a kitchen/living space and a bathroom. This type of house is the most commonly used in the subsidy housing supply, and needs to comply with all the necessary requirements as set out by the NHBRC.

The top structure is built on a suitable foundation dependant on soil conditions. Load-bearing and external walls are constructed with 140mm hollow concrete blocks, and the interior walls with 90mm masonry bricks. The NHBRC requires a plastered finish on the external wall to provide sufficient waterproofing, while the inside walls are required to be bag-washed if not painted. The roof consists of treated wood rafters, built onto the external walls. A galvanised sheet roof is then fastened to the rafters with screws that can support the calculated windloads.



- 2) **Poured systems** use a mould that outlines the profile of the interior and exterior walls of a home, and a concrete mixture is then poured into the mould and left to cure. The mould can either be reusable (such as the indigenous Moladi building system, which uses a plastic formwork) or it can be built in as an insulating or hard-wearing layer. Autoclaved aerated concrete is normally used due to its relatively high thermal efficiency.
- 3) **Framing systems** utilise a lightweight frame structure, made of wood or cold-formed steel, and panelled with prefabricated walls consisting of several layers. Light Steel Framed Buildings (LSFB's) fall into this category. LFSB's are constructed from prefabricated galvanised steel forms that are fastened together on site. The structure is then clad with plastered fibre cement board with the required waterproofing.
- 4) **Panelled systems** use prefabricated structural panels that offer a combined solution of strength and insulation in single units. These panels may be manufactured with wood, reinforced plastic or fibre-reinforced concrete. Tilt-up construction falls into this category.

#### ***2.2.4.4 Technical Requirements Relating to the Design and Construction of ABT Homes***

According to the NHBRC, several requirements must be met by an alternative design to be considered for wide-scale implementation. They are as follows (NHBRC, 2013):

- 1) Prescriptive "Deemed-to-Satisfy Rules", which are based on the SANS 10400 and the SANS 10401 codes of practice;
- 2) Rational Design or Assessment, whereby a detail design and structural analysis is certified by a competent person according to the Engineering Profession of South Africa Act 113 of 1990 (usually a Professional Engineer registered with the Engineering Council of South Africa);
- 3) Valid Agrément SA Certificate, which provides an independent technical assessment and certification of alternative building technologies.

Furthermore, the assessment criteria that apply to all designs and must be complied with are (SABS Standards Division, 2008):

- 1) Structural performance;
- 2) Fire resistance;
- 3) Water penetration;

- 4) Condensation and moisture performance;
- 5) Thermal performance;
- 6) Durability of structure;
- 7) Acoustic performance;
- 8) Method statement detailing the construction process;
- 9) Quality control procedure manual.

#### **2.2.4.5 Specific Challenges Preventing ABT Implementation in South Africa**

A review regarding the implementation of alternative construction technologies was published by the Department of Human Settlements in 2010. The review, which was based on several studies, found that several companies have trialled ABT solutions in a limited capacity but these have not progressed to widespread implementation although the national housing policy and building regulations did not specifically preclude companies from utilising ABTs in their projects. According to the review, the reasons for this slow uptake are (Department of Human Settlements, 2010):

- 1) A negative social perception of ABTs by beneficiaries;
- 2) Low quality of ABT structures;
- 3) Insufficient manufacturing capacities of ABT companies;
- 4) Lower utilisation of local labour compared to conventional building technologies;
- 5) High price of alternative building materials;
- 6) Irregular investment by government in ABT projects makes businesses unsustainable;
- 7) Procurement procedures that negatively impact upon ABT implementation;
- 8) Insufficient inspection procedures.

#### **2.2.5 Problem Definition for Housing in South Africa**

As outlined in Chapter 2.1.3, the challenges that prevent a significant decrease in the housing backlog relate to six primary issues, namely subsidies and financing for beneficiaries, affordability of housing, quality of housing, settlement planning and suitable land acquisition. These problems relate to difficulties encountered in the political, social and financial sphere of the built environment. However, would it be possible to approach these problems from a different angle, namely the technical side of the built environment? In addition, would a different technical solution be able to alleviate some of these challenges?

The conventional methods of construction are still preferred in large projects due to their labour intensive construction, the maturity of the technology, the physical performance of the product and the societal norm of owning a “brick house”. However, this solution is not optimal as it

induces significant construction time, a lack of workmanship and consistency is widespread and the use of low-density housing increases urban sprawl.

Can modern container architecture provide a possible solution?

## **2.3 Shipping Containers as an Alternative Building Technology**

Container architecture represents a new and innovative way of utilising fixed spatial units in the residential housing sector. Intermodal freight containers represent a modular, affordable and internationally available resource that can be refurbished at the end of its useful lifecycle as a shipping module, and “upcycled” i.e. used with minimum modification for another purpose (Pauli, 2010), in the built environment.

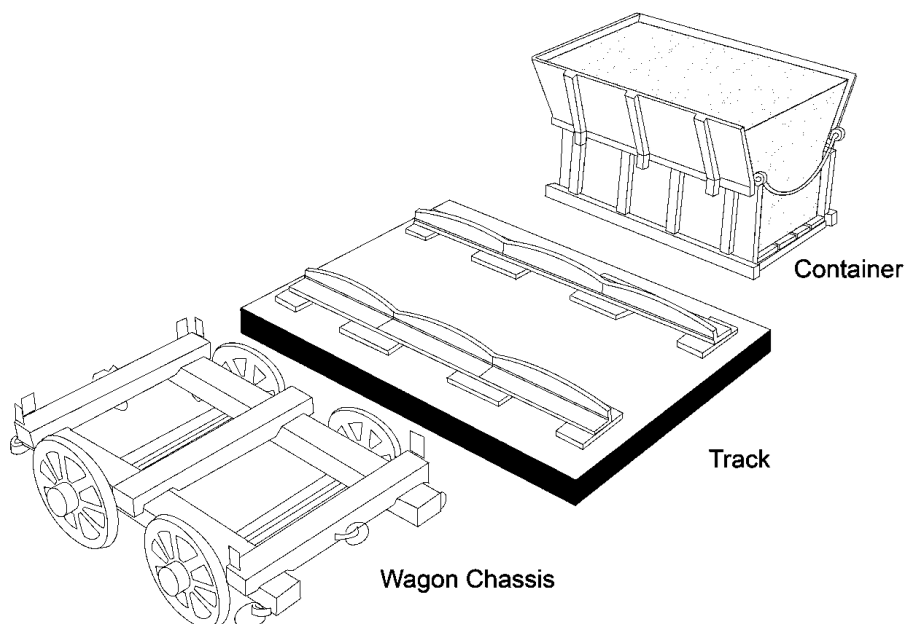
This chapter discusses the background and evolution of the container module from its simple industrial era origins, to a unifying symbol of global trade and as a current trend in modern architecture and affordable, housing design.

### **2.3.1 The History of the Intermodal Freight Container**

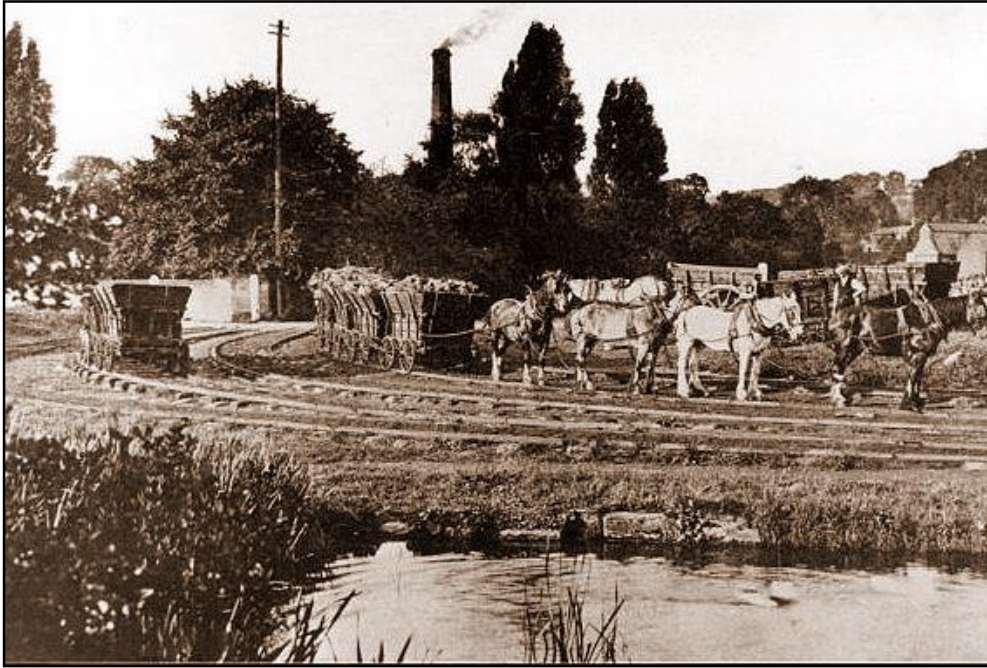
The concept of trade developed with the advent of human communication in pre-historic times. Archaeologists have dated the organised exchange as far back as the Upper Palaeolithic era of human history, roughly 17 000 BC, with pre-historic humans exchanging obsidian for flint in New Guinea (Darvill, 2008). With the rise of the great seafaring civilisations and the trade of Victorian-era nations, the transport of goods were mainly confined to barrels, sacks and crates, making the loading and offloading of ships a tedious and cumbersome process. Due to the labour intensity of loading goods, a ship could easily spend more time in port than it did faring the sea (Cudahy, 2006), while exposing cargo to risks such as theft and accidental loss (World Shipping Council, 2009). Right before the advent of intermodal freight containers, most goods were transported as “break bulk” shipping, which indicated that goods were shipped loose in boxes, barrels and other small packages dependant on type of goods. An analysis in the 1950’s found that 60-75% of the transportation costs of break bulk shipping was due to portside costs which is equivalent to handling charges in modern terms (Levinson, 2006).

The history of the modern intermodal freight container has its origins in the height of the British industrial revolution. The technological advances made in manufacturing and transport (the widespread adoption of cheaper steam power) created new and more effective methods of transporting ore and goods from mines and factories to their destinations. The primary means of cost-effective transport was by rail, river or sea, as transport cost by road was expensive.

The Butterley Iron-Works, which was located in the eastern part of Derbyshire in England, designed and built a type of wagon that operated from the late 18<sup>th</sup> century in a similar fashion to modern containers and container-carrying vehicles. It consisted of a wooden wagon-chassis (known as a “mule”) with a loose, open-type container loaded on top. The container cargo consisted of mined coal, transported by horse from the British midland collieries to the steelwork manufactories via the Little Eaton Gangway (Ripley, 1993). Cranes loaded the containers onto canal barges for further transportation, after the coal reached the river network, and then offloaded the containers again once the barges reached their destination. Figure 2.8 is a sketch prepared by the author, which shows the schematised breakdown of a coal wagon with its container. Figure 2.9 shows a wagon train *en route* to its destination, towed by horse.



**Figure 2.8** - Tramway wagon components (adapted from photograph by R. Bradley, 2013).



**Figure 2.9** - Little Eaton tramway (R. Bradley, 2013).

Containerised coal greatly reduced the transferral time from rail to river, and after the mid-19<sup>th</sup> century, several European continents employed this method of coal transport (Essery, et al., 1970). The idea of containerisation also spread to other industries: goods transport, luggage services, furniture removal and military logistics being examples. Although the use of containers started to become widespread, the problem of non-standardisation created incompatibility, and in turn caused a waste of time and labour due to hundreds of different standards, and deviation between countries.

The concept of a standardised container first originated with the British Railway Clearing House organisation. The purpose of the organisation was to allocate and manage revenue between the different railway corporations in Great Britain, and was responsible for unified technical standards applicable to all members. This included the first technical standard for all types of train wagons, although it only applied to British railway corporations. In the United States, railway companies started to standardise their freight containers as well but only within their own railway fleet (Essery, et al., 1970).

The United States Army created and used the first globally accepted standardised container in the early 1950's. As a way to combat pilferage and damage of transported goods, the US Army designed a 2.6x1.91x2.08m container near the end of World War II for the shipping of officer's goods. These early containers were designated as "Transporter, Household Goods,



Shipboard” and thus nicknamed “transporters”. A further improvement in the design regarding the structural strength led to the CONEX (short for “Container Express”) design during the Korean War, where it was approved to transport engineering supplies. Wartime logistic reports state that the use of CONEX containers cut down shipment time of supplies from 55 to 27 days, by removing dockside-unloading bottlenecks (Levinson, 2006).

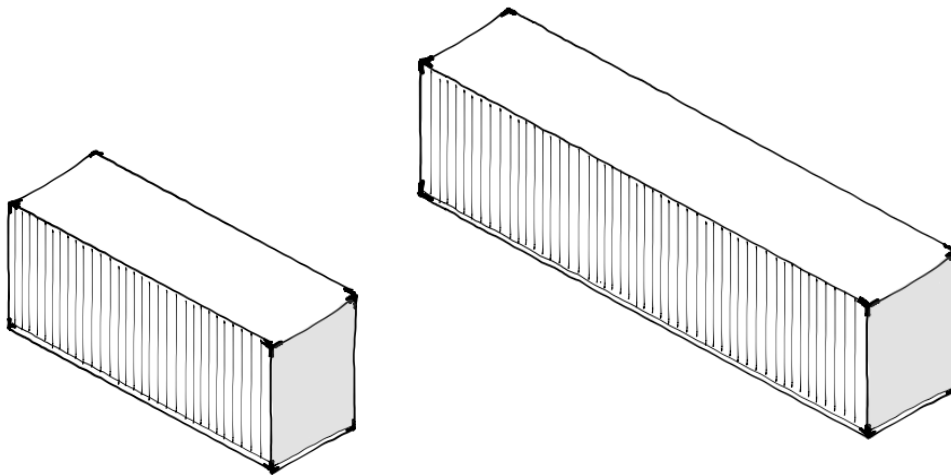
The birth of true intermodal freight container shipping for rail, road and sea can be attributed to Malcolm McLean, the founder of Sealand Services. Together with engineer Keith Tantlinger they developed a system of sealed containers capable of being transported by train or truck and delivered to specialised ships that only carried containers from one port to another. The goal was not only to develop a single type of shipping container capable of traversing land and sea, but also the infrastructure of port terminals and loading bridges to handle such a system. After establishing his successful haulage company, McLean envisaged a universal system for transporting goods across land and sea. The motivation behind his thinking is attributed to his understanding of factors that influence the price of freight, his desire to strip out the inefficiency of the shipping industry and his belief in the detachable truck trailer (which would streamline freight from distributor to shipper to consignee) (H. Slawik, 2010).

After McLean’s acquisition of the Pan-Atlantic Steamship Corporation, several of his competitors tried to stop his business by citing anti-monopoly laws. In response, McLean sold off his trucking company, and proceeded to only run his shipping company, which was renamed Sealand Services in 1960. The “SS Ideal X” was the first containerised vessel acquired by the company, which was a converted WWII-era T2 oil tanker. Although it had a newly built deck to support the containers, it did not have on-board loading gantries (ships converted after the Ideal X was fitted with new loading bridges aft and forward of the vessel’s superstructure to assist with the loading of containers). In the spring of 1956, the Ideal X was loaded with 58 freight containers and a load of liquid petroleum and sailed from Newark, New Jersey for the port of Houston, Texas. Figure 3 shows an over flight photo of the ship in transit.



**Figure 2.10** - The "SS Ideal X", the first ship to carry modern, intermodal freight containers (D. Eaves).

After the first few successful shipments of cargo, the container gradually gained worldwide acceptance as the *de facto* standard in shipping goods. Due to the high strength and durability of a freight container, it was increasingly used for other purposes around the world, from storage to temporary offices. It is from these alternative uses that the spatial and architectural possibilities of container design developed into the modern trend of converting freight containers into Intermodal Steel Building Units (ISBUs). See Figure 2.11 for a graphic representation of commonly found, modern containers:



**Figure 2.11** - The most common variants of containers found in South Africa today: the 20-footer (6m in length), and the 40-footer (12m in length).

### 2.3.2 Container Applications

Containers are often used as building modules where a need for temporary space exists. In the context of engineering, most construction sites will require a container or two to act as site offices. In addition, containers are also relatively widespread due to their use as a transport space and thus lead to short term, quick availability when one is needed (Slawik, et al., 2010). Depending on the need, a container solution can be developed for:

- 1) Public buildings;
- 2) Offices;
- 3) Residential housing (see Figure 2.11 as an example of a permanent container house);
- 4) Social/low budget architectural projects;
- 5) Commercial/corporate architecture;
- 6) Event/exhibitions;
- 7) Art installations;
- 8) Buildings that aspire to a container “look”.

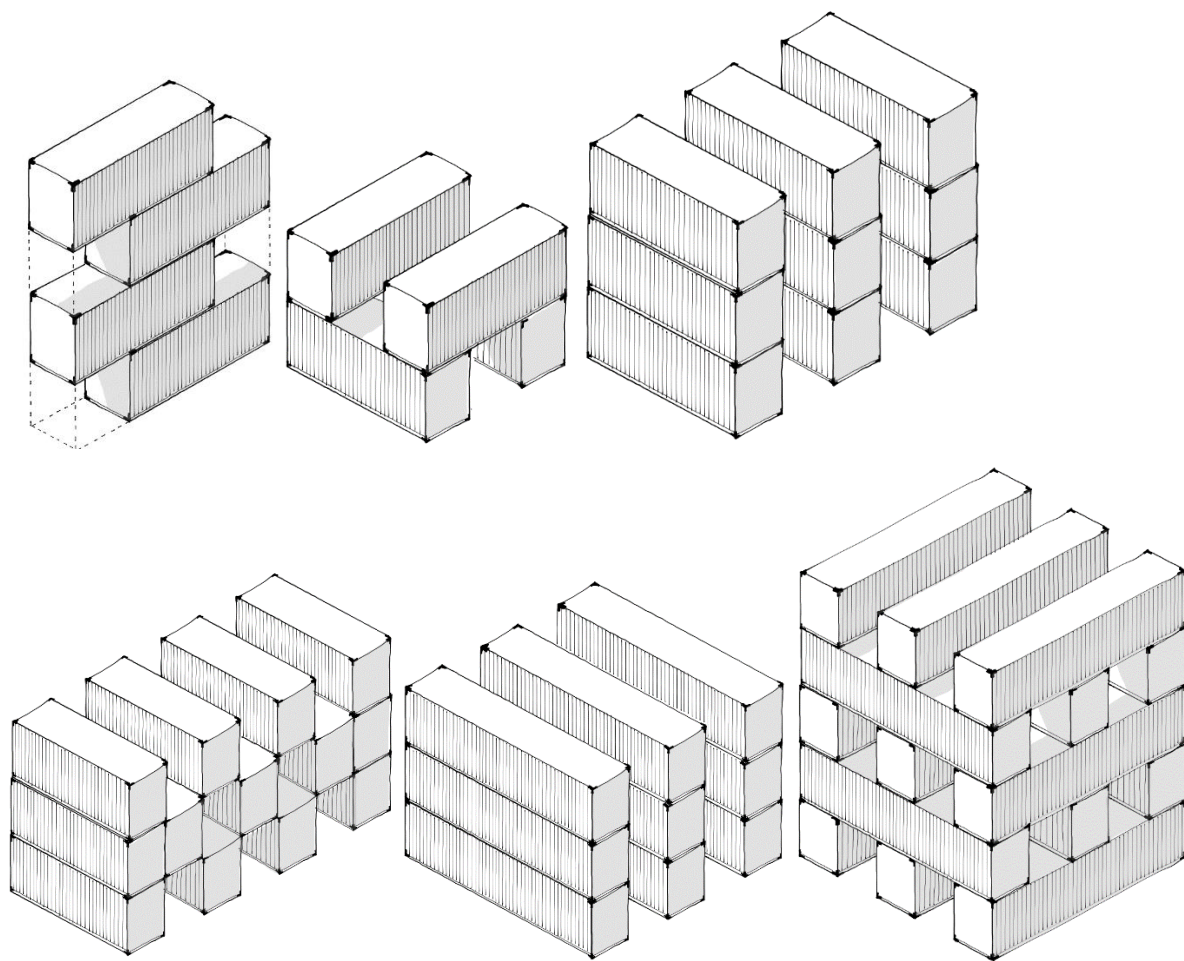


**Figure 2.12** - Redondo Beach Container House (Container Atlas, 2010).

The literature review shows a clear need for an easily implemented housing solution, with a modular design to cater for different community needs. The advantages of using an intermodal shipping container as basis for a home can possibly fill this need, while the disadvantages can be addressed with proper design and maintenance.

### 2.3.3 Aspects of Containers as Building Modules

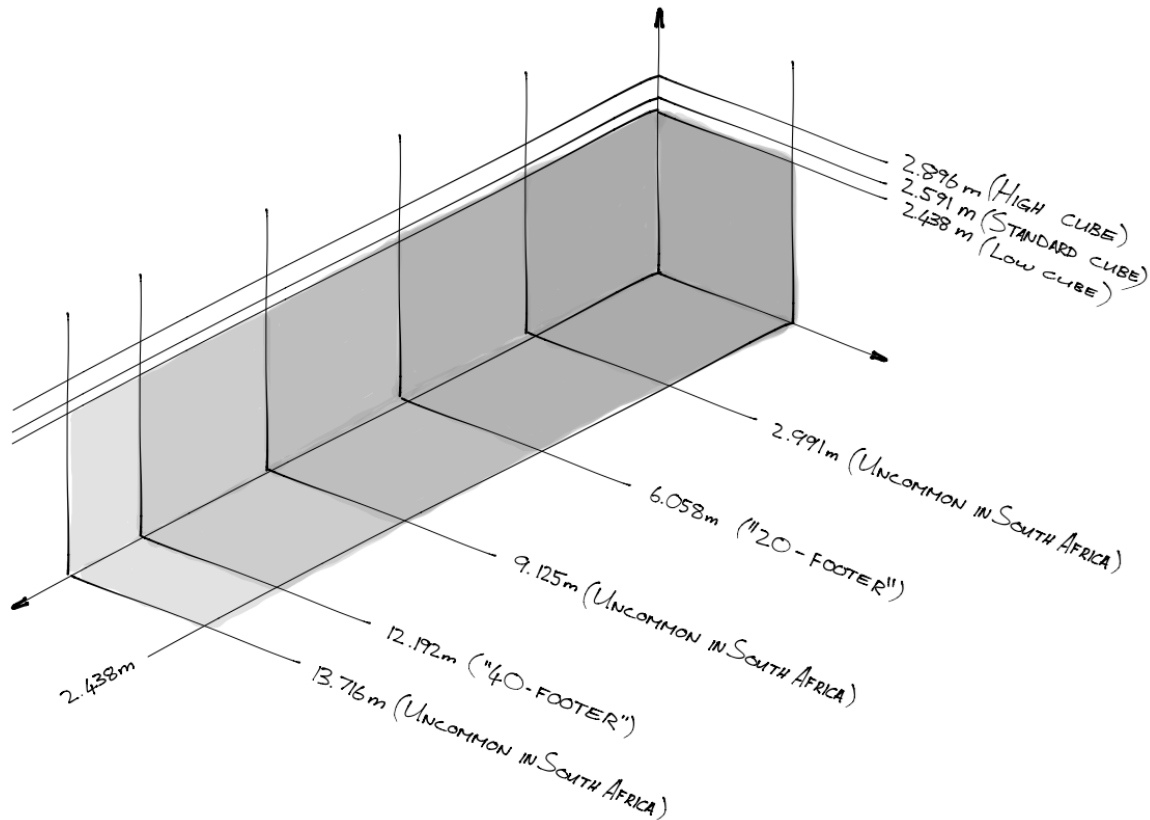
Containers are developed as single units that can be used as a modular, multi-purpose solution for spanning multiple spaces. This can either be in the horizontal direction or stacked vertical direction, as the structural strength of containers are more than sufficient to bear this load. Combination and staggered options are also possible, as shown in Figure 4.3.



**Figure 2.13** - Different possible ISBU stacking configurations.

The maximum stacking count of containers usually varies, but is standardised for a height of at least six units, with a maximum load of 24-tons per stacked container (Naber, et al., 2013).

There are two common sizes for freight containers, namely 6-meter (referred to as 20 footers) and 12-meter (referred to as 40 footers) length, high-cube freight containers. See Figure 2.14 for a visual depiction of freight container sizes available in South Africa:



**Figure 2.14** - Common freight container sizes (Adapted from Slawik, 2010).

The price range of new 12m high cube freight containers range between R48 000 and R60 000. The price for unserviceable containers differs depending on the fluctuating value of steel, the available supply of containers, the state of the shell and the amount of rework needed to refurbish it. The price range for a refurbished 6m container ranges between R15 000 and R21 000, while the price of a refurbished 12m container ranges between R22 000 and R30 000 (Spazatainer, 2013; Keuler, 2013; Gronloh, 2013).

### 2.3.3.1 Advantages as Residential Buildings

The advantages of utilising container homes are (Hart, 2013):

- 1) Inherent strength and durability that allows for multi-storey solutions;
- 2) High level of durability ensures low maintenance costs;
- 3) Modular design that allows for high density solutions, as well as expandability;
- 4) Easily transported;



- 5) A widely available resource;
- 6) Cheaper to build than comparable conventional homes in the commercial market;
- 7) “Upcycled” by using it as a home (instead of scrapping) and thus providing a reduced environmental impact.

### **2.3.3.2 Drawbacks as Residential Buildings**

Several disadvantages also exist, and need to be addressed accordingly (Gronloh, 2013):

- 1) High temperature conductance of bare steel shell;
- 2) Condensation due to high moisture content of uninsulated containers;
- 3) Specialised labour required for extensive container modification (factory-based);
- 4) Requires the extensive use of transport and cranes for lifting and placement procedures;
- 5) Building permits and certification required through Agrément SA;
- 6) Presence of solvents and toxic contaminants (such as lead chromate in the primer paint);
- 7) Severely damaged containers will not be able to be repaired;
- 8) Fluctuation of international steel prices, as well as an increased demand for containers can adversely affect prices.

### **2.3.4 As an Alternative Solution for the Affordable Housing Market**

It is possible that container-based housing solutions can prove to be more economically, socially or environmentally feasible than the current conventional construction method that is preferred in South Africa. Cost savings due to reduced implementation and construction periods can possibly lead to reduced investment costs.

Thus, from the limited evidence gathered after the development of the literature review, the researcher proposes the following research statement:

*“How is the use of Intermodal Freight Containers a better alternative to conventional construction in low-cost subsidised- and gap market homes in South Africa?”*

In order to test this statement scientifically, four different steps need to be followed (Montgomery & Runger, 2007):

- 1) State the null and alternative hypothesis;
- 2) Define the decision method;
- 3) Gather random data sample from population;
- 4) Make a decision based on the previously defined criteria.

Therefore, it is necessary to measure the sustainability of the alternative solution and compare it to the sustainability of a counter-performance solution based on current economic, societal and environmental indicators. In this case, the counter-performance solution will be the conventional construction method.

## **2.4 Conclusion**

This chapter provides the backdrop to the current housing challenges facing the country. To understand the scope of the challenge, it was necessary to examine the past and present housing policies as enacted by government.

The history of South Africa is fraught with injustice, and the effects of forcing different racial groups to live in separated areas still continue to plague the government. The effects of denying the poor full access to the economy has forced South Africa into one of the most unequal societies in the world, with a quarter of the population being unemployed (Statistics South Africa, 2012). The lack of well-located land that can provide communities with sustainable, economic growth is a pervasive issue, and one of the primary reasons that the backlog is not decreasing. However, as most of the backlog challenges relate to the political, societal and financial sphere of influence, one can but wonder if a different type of technical solution may help alleviate some of the problems.

The primary challenges were identified in the literature review, and existing alternative technical solutions were proposed to combat this. However, these solutions have existed in the marketplace for some time, and due to specific challenges they are struggling to gain large-scale adoption.

A different technical solution that has not been implemented as a widespread low-cost solution in South Africa was identified in the form of intermodal freight containers converted into living spaces. The advantages and disadvantages of the solution were defined and a research statement was developed to test the feasibility of this solution against the preferred conventional method. Chapter 3 develops this statement further into a quantifiable research framework that will act as the scientific background for the rest of the study

## CHAPTER 3

# RESEARCH DESIGN AND METHODOLOGY

### 3.1 Introduction

This chapter explains the research design and methodology of the study. It comprises the objectives of the research, its approach and design, instruments used, the reliability of the research, limitations thereof and the ethical aspect of performing a feasibility study.

### 3.2 Research Aim and Objectives

This research investigation is concerned with the utilisation of an Alternative Building Technology as a technical solution to address the primary challenges facing the housing backlog in South Africa. The impact of using prefabricated, modular Intermodal Steel Building Units as opposed to conventional construction is investigated and compared, and the feasibility of future housing projects using ISBUs is presented.

The key objectives of this research study are to:

- 1) Research the current context of low-cost housing delivery in South Africa, with regard to the social, political and financial sphere of influence;
- 2) Determine the primary challenges currently affecting housing delivery, and investigate currently used and proposed solutions;
- 3) Determine the primary parameters that will be used to compare an ABT solution with a counter-performance, conventional solution (economic, societal and environmental influences);
- 4) Develop a showcase technical housing solution with the use of Intermodal Steel Building Units (ISBUs) in accordance with the SANS codes of practice and the NHBRC requirements and compare it to a suitable conventional control case;
- 5) Perform a cost, time and quality assurance analysis between the ISBU and conventional solution;
- 6) Perform a social acceptability survey of an ISBU solution in an informal settlement;
- 7) Perform a lifecycle environmental impact assessment on the use of ISBUs versus conventional building methods and materials.
- 8) Deliver a feasibility assessment on the use of ISBU solutions for low-cost housing in South Africa.



### 3.3 Research Approach and Design

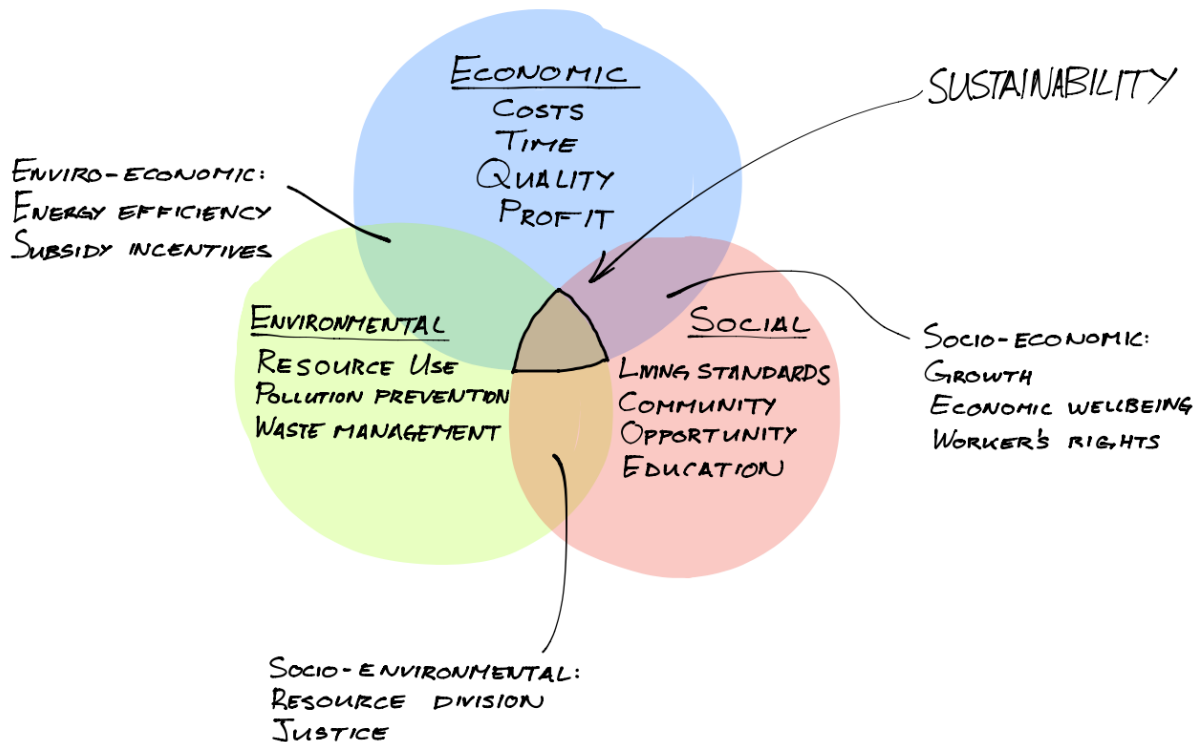
The design of research studies can be divided into three primary approaches, namely a quantitative approach, a qualitative approach or a mixed method approach. As specified by Creswell, if a research problem is “identifying factors that influence an outcome, the utility of an intervention, or understanding the best predictors of outcomes, then a quantitative approach is best” (Creswell, 2003). This study focuses on the feasibility of a technical solution and is dependant on several physical parameters. Thus, a quantitative approach was followed. The research statement, as developed in Chapter 2, is as follows:

*“How is the use of Intermodal Freight Containers a better alternative to conventional construction in low-cost subsidised- and gap market homes in South Africa?”*

In order to test this research statement, it is necessary to identify the dependent parameters. The most important parameter regarding the procurement of construction projects in South Africa is based on cost. However, several other parameters are also considered important, such as the level of Broad-Based Black Economic Empowerment that the procuring company subscribes to. Thus it is necessary to not only consider the comparison in terms of cost, but rather the sustainability of ISBU-based projects as well.

#### 3.3.1 The Principles of Sustainability

The United States Environmental Protection Agency provides the following definition of sustainability (United States Environmental Protection Agency, 2012): “Sustainability creates and maintains the conditions under which humans and nature can exist in productive harmony, that permit fulfilling the social, economic and other requirements of present and future generations.” This definition shows that the long-term sustainability relies on three different, entwined parameters, namely Economic, Social and Environmental sustainability. Adams elaborates further on this “three pillars of sustainability” definition, and combines it in a Venn-diagram, as can be seen in Figure 3.1 (Adams, 2006):



**Figure 3.1** - The “Three Pillars” of Sustainability (Adapted from Adams, 2006).

Accordingly, due to the diverse nature of factors affecting the feasibility of a construction project, it is important to broaden the research design to encompass the three different aspects of economic, societal and environmental influences. Therefore, to empirically test the main research statement, it is necessary to break it down into three sub-statements.

### 3.3.2 The Economic Parameter

*“The use of ISBUs is cheaper per square meter, take less time to construct and provide a higher product quality than the conventional construction method”.*

The comparison of the economic parameter is measured in units of time and financial cost. The impact of quality assurance is investigated but not measured empirically.

### 3.3.3 The Societal Parameter

*“An ISBU home is of an acceptable living standard to society if it resembles a conventional house”.*

The social sustainability parameter is dependent on the acceptability of containers as a building material. To measure the acceptance, a comprehensive descriptive survey was performed in an informal settlement. The survey aimed to study the negative perceptions that

beneficiaries have of alternative building technologies, and tested if proper marketing can improve the societal view of non-traditional housing.

### **3.3.4 The Environmental Parameter**

*“The use of ISBUs has a smaller life-cycle environmental impact than conventional construction methods”.*

The environmental impact of utilising ISBU housing is based on a quantified model that specifically measures the environmental dimension of sustainability. This method was developed by Brewis as a means to practically measure the sustainability of alternative building technologies in South Africa (Brewis, 2012).

### **3.3.5 Test Case Design**

There are no known historical, local case studies available regarding permanent low-cost housing with the use of containers in South Africa, and thus it is impossible to source random data samples of the cost, construction time, social acceptability and environmental impact. There are a few examples of upmarket commercial residential developments utilising ISBUs, and these projects will serve as the backdrop to an affordable design. One of these is the Windsor Park development that was constructed in Johannesburg in 2012 with the use of repurposed shipping containers.

Due to this limitation, it is necessary to design a low-cost test case. This design will subscribe to the requirements for ABT solutions as advocated by the NHBRC and the SANS codes of practice. A control case is also developed so that a comparison can be made. This control case is based on case studies that provide the data.

## **3.4 Research Instruments**

Three techniques were used to gather quantitative data for this research and are discussed in the following sections.

### **3.4.1 Construction & Manufacturer Data**

Several interviews and requests were made to fabricators and architects working in the prefabricated construction environment in South Africa with regards to physical costs, construction times and performance of ISBU based homes. The use of different fabricators provide a cost range as opposed to a single value, and gives an indication of possible market fluctuation that may affect the affordability of ISBU projects.

### 3.4.2 Case Studies

Several case studies of low- and medium-density housing in the Western Cape were reviewed to help develop a feasible control case solution. Data from these sources are based on already implemented projects and thus provide realistic costing data for the conventional control case solution. An ISBU residential development in Windsor Park, Johannesburg also provides useful data on how a container-based low-cost solution can work in South Africa.

### 3.4.3 Descriptive Survey

The purpose of the survey was to evaluate the negative perceptions that prevent the large-scale implementation of ABT based housing. However, the survey was not designed to address the social acceptability of all ABT solutions. It was tailored to specifically test the acceptability of an ISBU solution, as opposed to a traditional home. The sampling procedure of the survey was based on a newly developed informal settlement in Caledon, Western Cape where 570 new houses have been constructed since mid-2012. Door to door surveys were carried out by means of trained assistants and a total of 231 houses were surveyed on their housing preferences. The respondents were shown a series of figures depicting the differences between conventional home and a container-based home. These figures consisted of photographs, computer-modelled designs and plans.

## 3.5 Limitations of the Study

Due to the modularity of ISBU solutions as well as the variability of project needs, it is impossible to model every possible ABT variation. Thus, a general solution was sought in the design of the test cases in Chapter 4, based on the needs of the stakeholders in the built environment. The test cases are not finalised designs, but are developed as concepts to test the feasibility of a real world solution.

In terms of the social survey, it is only possible to present single-storey housing solutions. This is due to the rural and low-density nature of the settlement, where medium-density housing is outside the scope of the beneficiaries' reference framework. A survey in a higher-density settlement was not conducted, as local settlements in the Cape region experienced high levels of unrest and violence during the study period.

One of the primary objectives of the study is the comparison of ISBU and conventional homes, in single and multi-storey configurations. However, the available data and cases studies on multi-storey conventional housing vary to a high extent. In comparison, single-storey housing is more rigidly defined (for both conventional and alternative technology cases) and sufficient

for a broad comparison. For this reason, the costs of multi-storey conventional housing is pinned to market price per square meter. The figures are obtained from fabricators.

The total amount of available containers that can be repurposed is not publicly available, as shipping lines do not disclose their fleet replacement figures. To obtain a rough estimate of fleet container replacements per annum in South Africa, the study considered global turnover percentages of shipping containers and the total shipping tonnage per annum in South African ports. This does not provide an accurate estimate, but it does give a ballpark figure of available containers.

The environmental impact of container construction is very low when compared to conventional construction according to some sources; however, the necessary information required for a complete lifecycle environmental analysis (from cradle to grave) for containers is lacking, and thus it was decided to only investigate the construction phase of ISBUs.

### **3.6 Ethical Considerations**

The purpose of this research report is to investigate the feasibility of a new and different ABT that has never been implemented by government (and only in a few instances by commercial developers) in the low-cost housing sector. However, there is a real risk of not viewing the solution objectively and thus “promoting a product” instead of testing the actual feasibility.

Secondly the execution of a survey in an impoverished informal community could have been construed by the residents as a promise to receive “free housing” due to the nature of the questionnaire. To prevent residents harbouring feelings of resentment against the municipality, it was decided to carry out the survey without direct visible assistance of the Theewaterskloof Municipality. In addition, each respondent had to be informed that the survey was performed under the authority of Stellenbosch University and a signature of assent had to be obtained by the interviewers.

### **3.7 Chapter Conclusion**

This chapter discussed the research statement that determines the central theme of this study, namely if ISBUs can provide a “better” solution to the challenges facing the housing backlog in the country. To measure the validity of this statement, it is necessary to break it into measurable units that will shape the decision on whether this ABT is feasible or not. In addition, it must be compared to a counter-performance example in the form of a conventional project based on these values.

A test case utilising ISBU construction, and a control case utilising conventional brick and mortar construction need to be created to simulate actual performance and impacts. These will then be compared to each other based on economic parameters, environmental parameters and the social acceptability. This will result in a final feasibility matrix of a general ISBU solution in the low-cost housing sector in South Africa.

## CHAPTER 4

# ISBU TEST CASE REQUIREMENTS AND DESIGN

### 4.1 Introduction

This chapter contains the development, design and testing of two ISBU-based solutions. These solutions act as the primary comparison cases in the research report, and are measured against conventional solutions in terms of economic, societal and environmental benefits.

The first part of this chapter focuses on the requirements of the test case design according to the political, social and financial problem definition as synthesised from the literature review, as well as architectural, structural and practical considerations that can be taken into account to provide an optimised solution. This forms the basic framework of the ISBU-based design, with the necessary constraints and criteria that will make it suitable as a solution. The requirements for the design according to the SANS codes of practice and the NHBRC are discussed next.

The second part of the chapter then progresses to the concept design of the test cases, which are divided into different parts: the foundation, top structure, cladding/insulation, roof, construction method statements and expected maintenance of the home. This design is shaped according to the requirements of the first part of the chapter, and provides guidance on how to achieve an optimal solution. Two structural analyses are conducted to determine if strengthening and stiffening would potentially be required, although its purpose is not to find definitive answers.

Finally, the chapter concludes with the two test case designs, that will be compared against their equivalent, conventional counterparts.

### 4.2 Design and Testing Requirements

Several challenges facing the eradication of the housing backlog in South Africa were highlighted in the literature review, and it was suggested that the use of Intermodal Steel Building Units, a.k.a. ISBUs, could provide a suitable technical solution that can address some of these challenges. The purpose of this section is to develop the pre-concept design constraints that will apply and shape the ISBU test cases according to several requirements

dictated by the political, financial, societal and engineering spheres of influence on the built environment.

## **4.2.1 Requirements for Addressing the Challenges of the Housing Backlog**

### **4.2.1.1 Political**

The lack of suitable land is a large problem for the development of new housing projects, with new land being either unusable or not economically viable i.e. too expensive. In addition, the BNG approach of developing sustainable communities increases the acceptance criteria of suitable land (by minimising travel distances to work and school for example), and thus decreases development opportunities.

In order to combat this, a shift to higher density housing is advocated. For this reason, two test cases will need to be developed. Firstly, a test case comparing low-density ABT housing against a low-density conventional housing control case is needed as this is the most common widely implemented solution in South Africa. Additionally, because a survey will be carried out to determine the social acceptability of ISBU housing, a test case relating to the beneficiaries' frame of reference is critical, as a completely new and strange design can skew results.

Secondly, a medium-density ABT housing test case versus medium-density conventional housing control case is needed to investigate the feasibility of utilising higher density housing in the subsidy and gap market.

### **4.2.1.2 Social**

There exists a negative perception regarding the use of ABTs among beneficiaries, as they consider alternative housing solutions as being lower quality homes according to a study performed by the Department of Human Settlements (Department of Human Settlements, 2010). Thus, the design should avoid elements that can introduce probable points of failure (and thus a decrease in quality) in the solution. The end quality will depend not solely on the design, but also on the quality system that will be implemented by the contractor, and enforced by the client.

A second societal requirement relies on the use of local labour. If one considers the use of complete prefabrication for the test cases, it can result in less local labour needed during the construction phase of a project (Hart, 2013). Considering the high unemployment rate in South Africa, which is approximately a quarter of the population according to the recent census (Statistics South Africa, 2012), this would be extremely undesirable and unacceptable to the participating community. Thus, on-site manufacturing is the preferred construction option, as



it will maximise the use of the local population to build their houses, and thus uplift them economically.

#### **4.2.1.3 Financial**

As discussed in the literature review, the affordability of housing at the lower end of the commercial market is still too high for low-income entrants to gain a foothold. This has led to a housing backlog in both the subsidy and gap market, with subsidy housing being prioritised by local government. The existence of subsidy programmes for the gap market such as FLISP is not enough to raise the buying power of entrants to get into the commercial market. In addition, developers are also wary to invest into lower-cost housing, as the risks are significantly higher.

The designs need to be viable either as a subsidy housing solution, or as a gap market solution. For subsidy housing, the total cost of the top structure should not exceed R65 000 to R100 000, as that is the range for a conventional BNG housing solution. If the design caters for the gap market, the total top structure cost should be between R100 000 and R250 000, which is the range between the high-end of subsidy housing, and the low-end of the commercial housing market.

### **4.2.2 ISBU Design Optimisations**

#### **4.2.2.1 Prefabricated Manufacturing versus On-site Construction**

The purpose of prefabrication can most easily be described as shifting construction from a site to a factory environment; thus it can be expected that there would be some savings regarding cost, time and quality (de Klerk, 2013). However, to accomplish this in the scope of ISBU based construction, one would need a significantly large facility to prefabricate modular units for residential projects. In addition, the use of an off-site facility for fabrication would lead to significant loss of the need for local labour (de Klerk, 2013). This would be desirable in developed countries, where automation and mechanisation are preferred, but not in South Africa.

A better alternative would be to manufacture on-site, by having the refurbished shipping container units transported to the construction location (with as many building materials packed inside to maximise efficiency, if possible). All the necessary cutting, fitting and finishing would occur on-site with the use of trained and local labour, and there would be no need for a specific manufacturing facility. See Figure 4.1 for an example of hybrid on-site construction:



**Figure 4.1** - On-site manufacturing of ISBU residential building (M. Hart, 2013).

#### **4.2.2.2 Hybrid- versus Modular Container Design**

The price of a container versus the amount of space it provides is quite high, with a 6m container shell costing approximately R1 214/m<sup>2</sup>, and a 12m container shell costing R968m<sup>2</sup> (excluding insulation, finishing, transport and installation). Therefore, a design that purely utilises containers can exceed the pricing bracket of low-cost housing (which range between R1 625m<sup>2</sup> for subsidy housing, and up to R8 000m<sup>2</sup> for gap housing). The design can thus be optimised to utilise the high structural strength of the containers to carry the building load. Additionally, by spacing or staggering them, an increase in floor area can be gained at minimal cost. See Figure 4.2 for an example of a hybrid design using modular building containers:



**Figure 4.2** - Spaced container design for offices (FSM, 2013).

#### **4.2.2.3 Semi-detached Design to Increase Cost-effectiveness**

The concept design can further optimise costs by utilising only 12m containers instead of 6m containers. National Housing Policy dictates that the minimum living space allowable for a home must be at least 40m<sup>2</sup>, which is equal to either three 6m containers (internal dimensions,  $3 \times [5.895 \times 2.35] = 41.6\text{m}^2$ ) or equal to one and a half 12m containers ( internal dimensions,  $1.5 \times [12.024 \times 2.35] = 42.4\text{m}^2$ ). As 12m containers cost less per square meter, it would amount to significant cost savings if three 12m containers, put side-by-side, could house two families. In addition, by removing the middle container and utilising the open space (and even enlarging it), one can optimise costs even further.

#### **4.2.2.4 Lifting Procedure for Stacking Containers**

The lifting procedure for putting the containers into their final position is critical, and this phase of construction can have a large effect on the final product. The structural strength of a container depends on the interaction between its steel square tube frame, the steel channels that support the floor and the corrugated steel profiles of both walls and the roof. Together these elements act to carry all vertical and shear forces that act on the container during transportation with a load. However, that very nature of container conversion into ISBUs relies on the cutting and modification of the steel profile walls. By removing sections of steel wall for doors, windows and room enlargements, the strength of the container is drastically reduced. Special care must be taken during the strength analysis to ensure that the container can carry both the lifted load during the lifting procedure with minimum deformation, as well as the final stacked load of the completed structure without buckling. If too much deformation occurs during the lifting procedure, the container may sustain damage. In order to prevent this, additional temporary bracing may need to be connected during the procedure.

Attention must also be placed on the constraints of the crane that is used, its maximum lift capacity and maximum boom reach capacity under certain loads.

#### **4.2.3 NHBRC Compulsory Requirements and SANS Codes of Practice**

The NHBRC advocates that a comprehensive report be compiled for all new residential projects regarding several factors as mentioned in the literature review. Additionally, all factors must comply with the SANS10400 codes of practice. This section provides more detail on the specific requirements, and how they apply to the test case designs.

##### **4.2.3.1 Structural performance**

The SANS10400-2008 code of practice states that, “*Any building and any structural element or component must be designed to provide strength, stability, serviceability and durability in*

*accordance with accepted principles of structural design”* (SABS Standards Division, 2008). Thus, to comply with this directive, the design must subscribe to the several SANS codes of practice, namely:

- SANS 10100-1: The structural use of concrete;
- SANS 10160: Basis of structural design, imposed loads and wind actions
- SANS 10162: The structural use of steel;
- SANS 10163: The structural use of timber; and
- SANS 10164: The structural use of masonry.

The test case design will make use of concrete for floor slabs, significant use of steel and timber for the roof truss. However, masonry will not be used in any structural elements, and thus need not be considered in the design.

A structural analysis will be performed to ensure that the containers can sustain the static long-term load capacity needed for the multi-storey test case, as well as the lifting procedure for the single- and multi-storey cases.

#### **4.2.3.2 Fire resistance**

Regarding fire resistance, aspects such as safety distances, building occupancies, floor area divisions, fire performance of construction materials, stability of structural elements when exposed to fire, partition wall fire resistance, roof coverings, floor coverings, internal finishes, escape and emergency route provision, stairways and building material sections apply to these specific test case designs. The standard code of practice regarding fire resistance in a building should be followed; however, design according to this parameter is outside the scope of this research.

#### **4.2.3.3 Water penetration**

All aspects dealing with damp and water ingress are covered in this section, as well as measures to avoid water penetration. This is especially important in modular-type housing, as proper quality control of joints and sealing must be applied. Waterproofing of the roof must also be sufficient and capable of being easily repaired.

#### **4.2.3.4 Condensation and moisture performance**

The moisture performance of a house is largely dependant on the humidity, climate and indoor sources of moisture in a home. Minimisation of crawlspaces, proper ventilation and efficient

humidity control measures must be detailed. This factor ties in closely with the thermal performance of a home.

#### **4.2.3.5 Thermal performance**

The thermal performance of a home is directly related to the degree of insulation applied to the walls, floors, ceiling/roof and windows. The higher the rating of insulation that is applied, the lower the thermal conductivity and the higher the resulting heat efficiency of a home. This aspect will be investigated in the design section regarding the insulation.

#### **4.2.3.6 Durability of the structure**

This relates to the “*retention of performance requirements relating to structural safety and serviceability over the design working life of the house*” (National Department of Housing, 2003). This aspect is addressed via the design when considering the future maintenance of the structure.

#### **4.2.3.7 Acoustic performance**

The acoustic performance of a house refers to level of sound that can reach the occupants from adjacent houses and streets. This factor is mainly affected by the density of the walls, with a higher density leading to a lower level of sound propagation (Gronloh, 2013). This is a large drawback of container-based housing, as sound propagates quite easily through steel. The application of concrete floors and high levels of wall insulation will serve to dampen this effect slightly.

#### **4.2.3.8 Method statement detailing the construction process**

The method statement details the construction process of the test cases and is a very important piece of planning. This involves every aspect of construction, from site establishment to foundation pouring, erection, finishing and site disestablishment. Lifting procedures also need to be detailed in this document, as well as the necessary safety and risk assessment procedures that will be followed during the construction phase of the project.

#### **4.2.3.9 Quality control procedure manual**

The quality control procedure (usually referred to as the QCP in the construction industry) determines the inspection, snaglisting of construction issues and sign-off, with the intent of ensuring delivery of a high-quality end-product. Many large-scale contractors subscribe to the ISO9001 standards of quality assurance in South Africa.

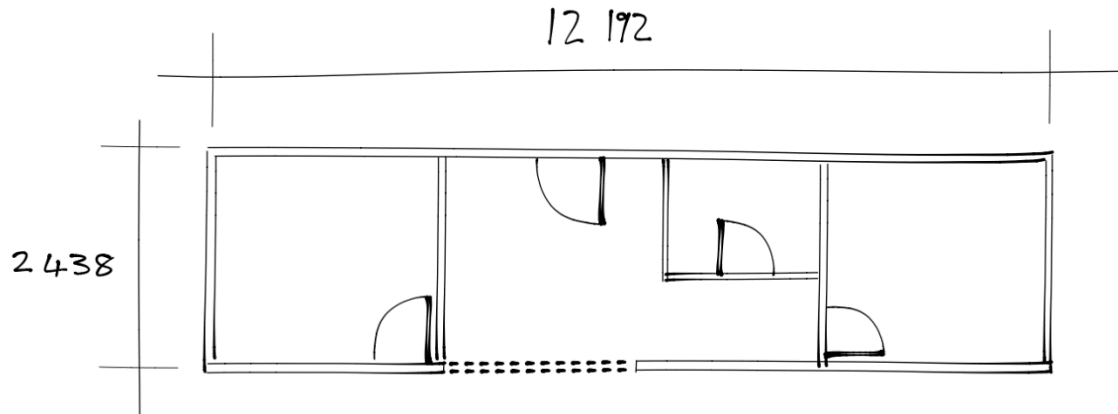
### 4.3 Concept Test Case Design

The previous section detailed the requirements of the test case solution in terms of the challenges of low-cost house provision, the codes of practice and several optimal design choices. The concept test case is created by taking these requirements into account, and building up the design step by step. The following sections provide the detail of the design by breaking it up into the separate building elements.

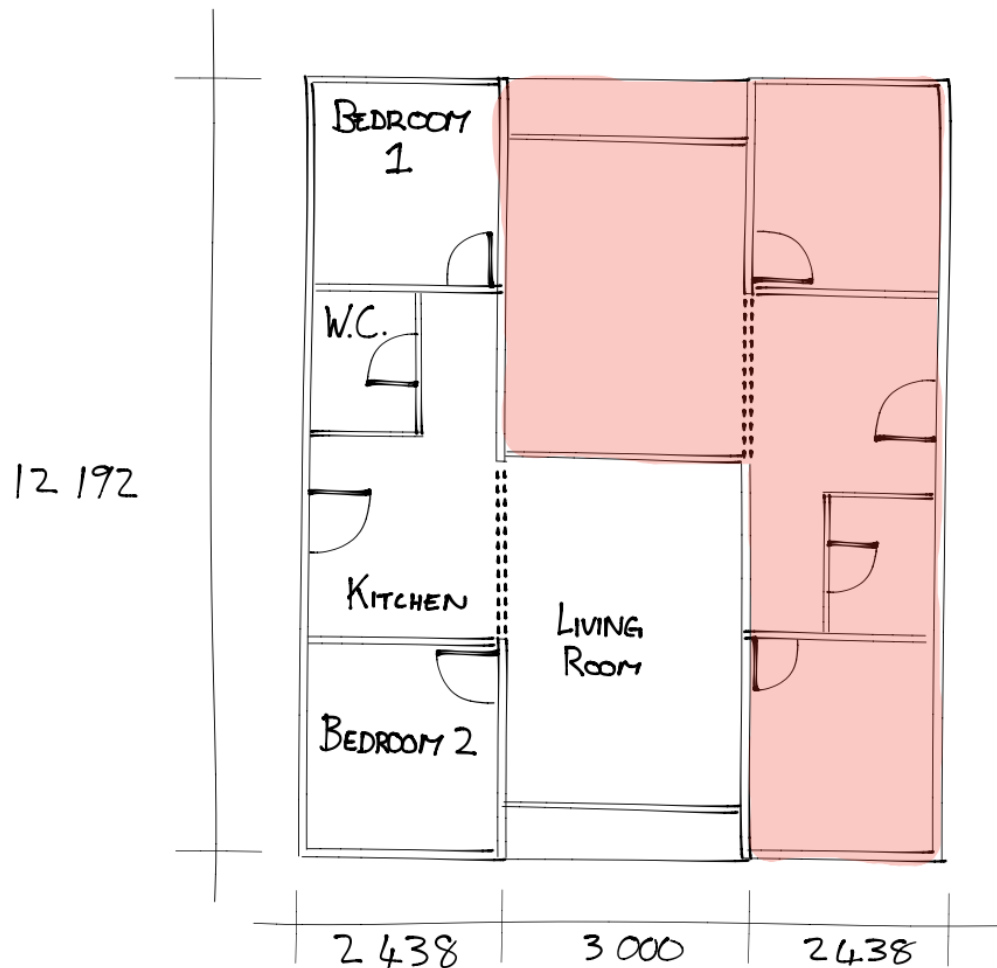
#### 4.3.1 Overall Design Plan

The structure type can be defined as a semi-detached, hybrid, on-site manufactured, intermodal steel building unit house, with each side of each unit consisting of one 12m refurbished steel freight containers, with a 3m space between the other unit's container. The total floor area of this configuration is 96m<sup>2</sup>. Each storey is capable of housing two families in two apartments with a floor area of 48m<sup>2</sup> each. Each apartment will have with two bedrooms, a bathroom, kitchen and living area. Insulation for the house is constructed with the use of 35mm thick Expanded Polystyrene (EPS) walls, affixed by means of wooden battens to the sides of the containers with an exposed wire mesh. The internal wall (which separates the two families) is 70mm thick EPS. The finish on the EPS walls is a shotcrete plaster, sprayed onto exposed wire mesh. The floor of the containers is poured concrete, with a nominal reinforcement mesh. The wooden floorboards of the containers are removed and not reused. The ceiling of the containers are also fitted with EPS but not finished with shotcrete. In order to prevent leakage and heat-loading, a galvanised-sheet roof is added. The roof truss used is a Fink-type truss, as the use of welded steel profiles directly onto the container-roof can provide cost savings with this configuration.

For the multi-storey test case, the containers are stacked vertically, with external stairs on both sides of the building. The 3m space between the containers has a floor slab on each level (except the ground floor) with permanent formwork consisting of shaped EPS and steel reinforcement. See Figure 4.3 for the container component of the test cases, and Figure 4.4 for the plan layout of the complete structure:



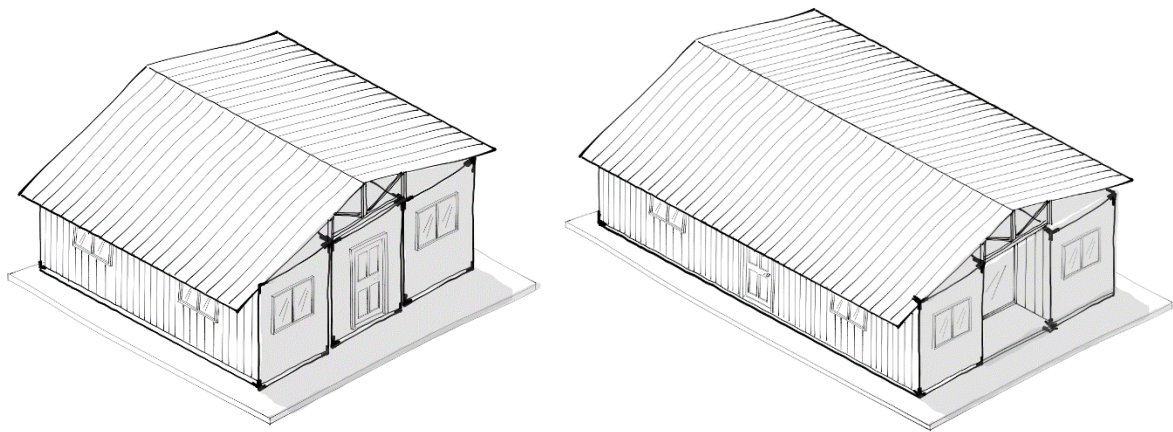
**Figure 4.3** - Early concept layout of 12m container, which acts as the ISBU house main component. This module has an approximate floor area of 28.5m<sup>2</sup>.



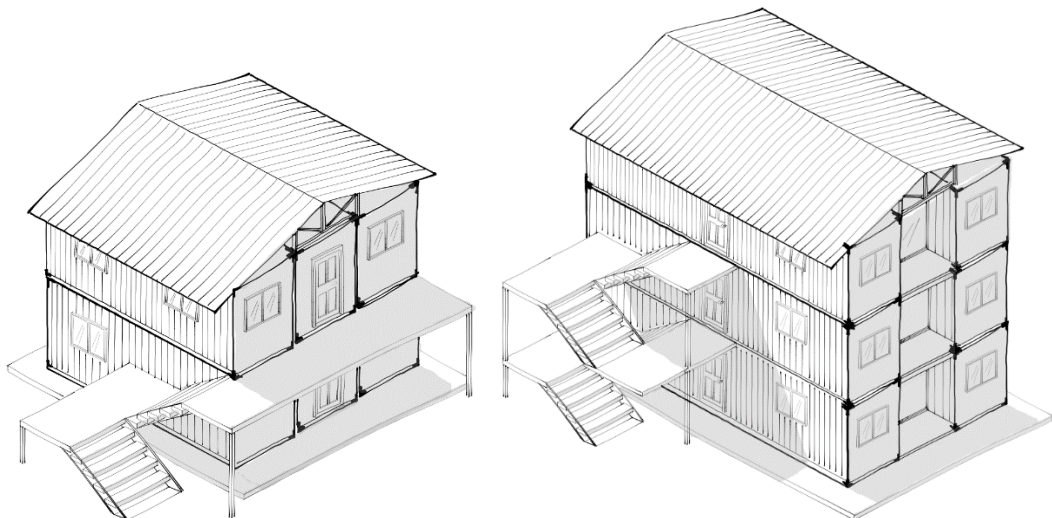
**Figure 4.4** - Early concept layout for low- and medium-density hybrid-ISBU housing test cases using 12m containers. This configuration provides two apartment units with an approximate floor area of 48m<sup>2</sup> each.



Several cut-outs in the containers are required for the doors, windows and the living space entrance. Cutting for these sections will take place on-site before the container is lifted into place. A finite element analysis to calculate the structural stability is conducted in the next section. After the container has been lifted into place, the window frames, door frames and the EPS panels will be fitted. See Figure 4.5 and Figure 4.6 for conceptualised versions of the finished houses.



**Figure 4.5** - Early concept configurations for low-density, single-storey hybrid-ISBU housing, with a galvanised roof (6m container- and 12m hybrid versions).



**Figure 4.6** - Early concept configurations for medium-density, multi-storey hybrid-ISBU housing, with a galvanised roof (6m container- and 12m hybrid versions).

The foundations of the structures are similar to the conventional case due to the lower weight of the structure, i.e. strip footings and a 150mm floating slab foundation. The soil



level of the middle “room” is raised a further 150mm as well, to level up with the floors inside the containers. In order to save on concrete, the use of EPS slats inside the bulk of the floor can be used.

#### 4.3.2 Top Structure Analysis of 12m ISBU Configuration and Design

The container configurations for the two test cases were analysed for two different load cases, namely:

- The lifting procedure, to ensure no significant deformation takes place that may irreparably damage the container; and
- The long-term static load case, with the containers carrying the load of occupants, floor slabs and other additional loadings.

The purpose of this analysis was to determine if the container would need additional strengthening during the lifting procedure to avoid excessive deformation, and to determine if additional strengthening would be required for the permanent static-load case of a multi-storey configuration.

Due to the anisotropic nature of the steel wall profile of the containers, together with asymmetrical cut-outs, it was necessary to carry out the structure analysis with the use of a finite-element analysis (FEA) tool. In this case, the FEA software *Prokon* was used to obtain accurate results. The modelling of the finite element model is described in detail in the next section.

##### 4.3.2.1 Finite Element Modelling (FEM) of Modified 12m ISBU

The container finite element model was based on the four different structural parts of a freight container: the ribbed steel profile walls, the ribbed steel profile roof, the container frame and the steel chassis that support the floor. The exact dimensions for the elements of the container was obtained from the German “Container Handbook”. The container was modelled with COR-TEN weathering steel as the general material, with the properties as seen in Table 4-1:

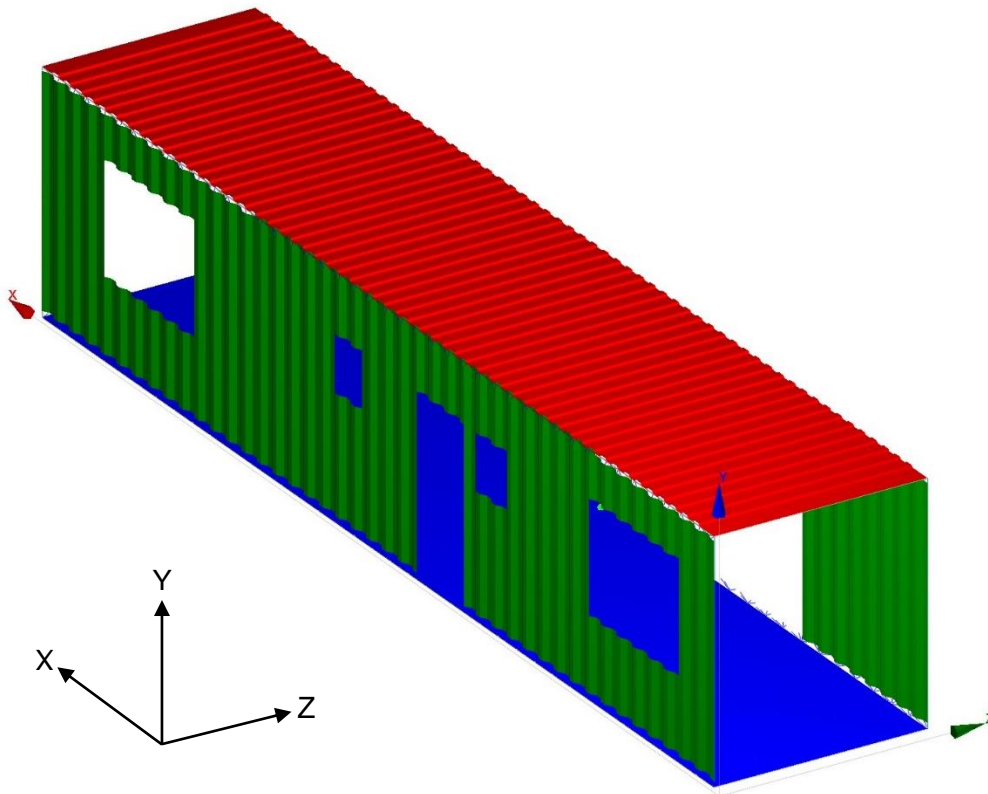
**Table 4.1** - Properties of COR-TEN Steel.

Specification	Grade (without impact test designations)	Nominal Yield Stress (MPa)	Country/Region
ASTM A588	COR-TEN A, B or AF	345	Canada

(Southern African Steel Construction Handbook, “The Red Book”)

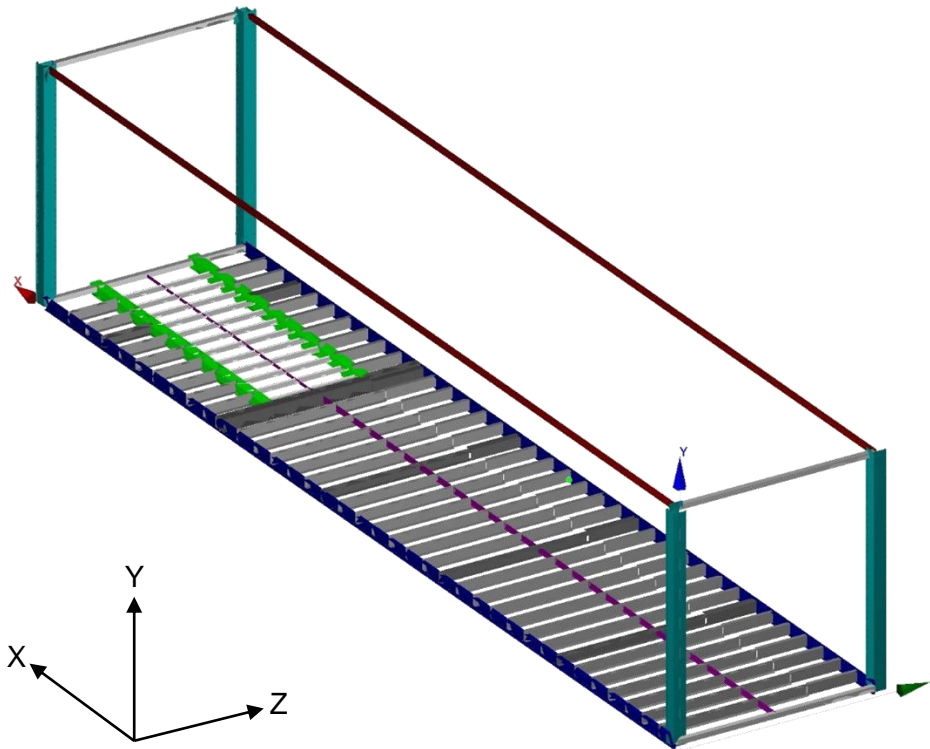
The steel profile walls were modelled in 70x70mm rectangular shells, with a thickness of 2mm. This was done for two reasons: firstly to approximate the steel profile as accurate as possible, and secondly to enable the ability to block-delete elements to fit different cut-out sizes (such as the windows, doors and living spaces).

The steel profile of the roof was similarly modelled, although no cut-outs was necessary. However, the loading of the roof with a concrete dead-load and live-load is necessary to calculate the total deformation from the static loading. See Figure 4.7 for the completed shell FEM.



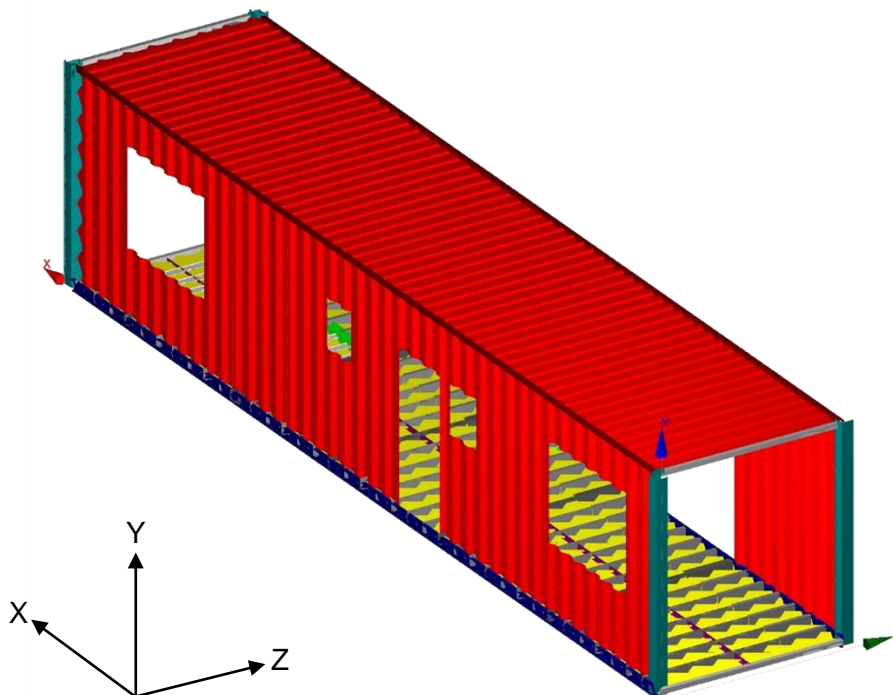
**Figure 4.7** - FEM shell modelling for container with living space, window and door cutouts.

The steel beams of the frame and container chassis needed to be modelled individually from accurate container schematics (refer to Annexure B for complete container drawings and further details of FEA modelling). See Figure 4.8 for the FEA model, showing only the modelling of the beam elements:



**Figure 4.8** – FEM beam model, showing the container frame, chassis and gooseneck tunnel.

The completed 3D model combining all beam and shell elements, is shown in Figure 4.9:



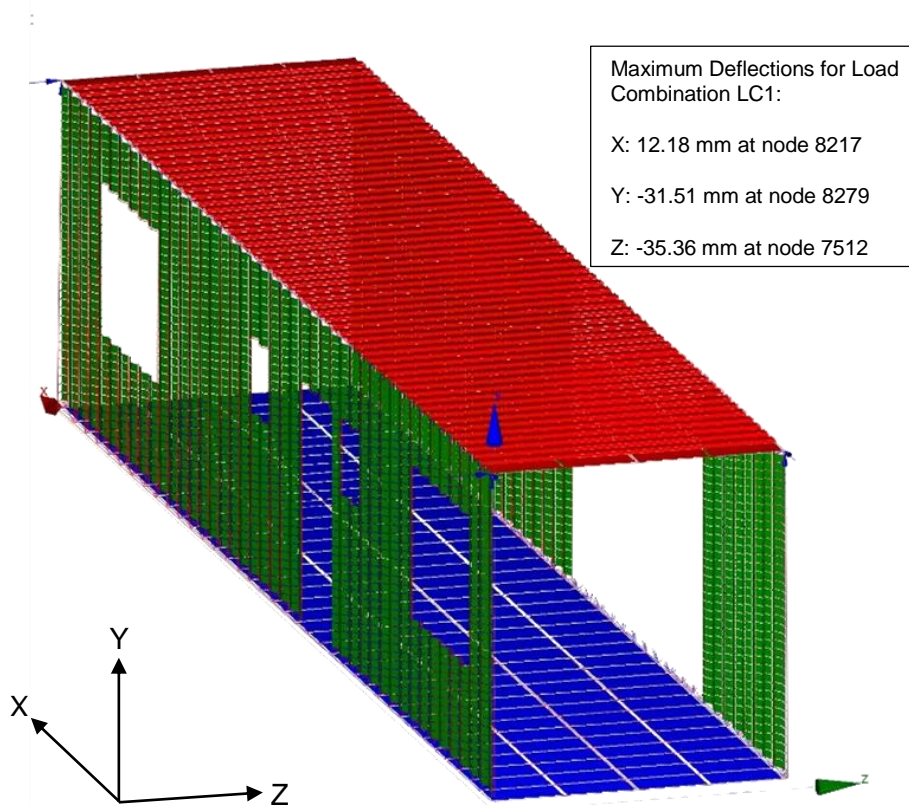
**Figure 4.9** - Completed FEM 3D model.

#### 4.3.2.2 Finite Element Analysis Results of Lifting ISBU-element

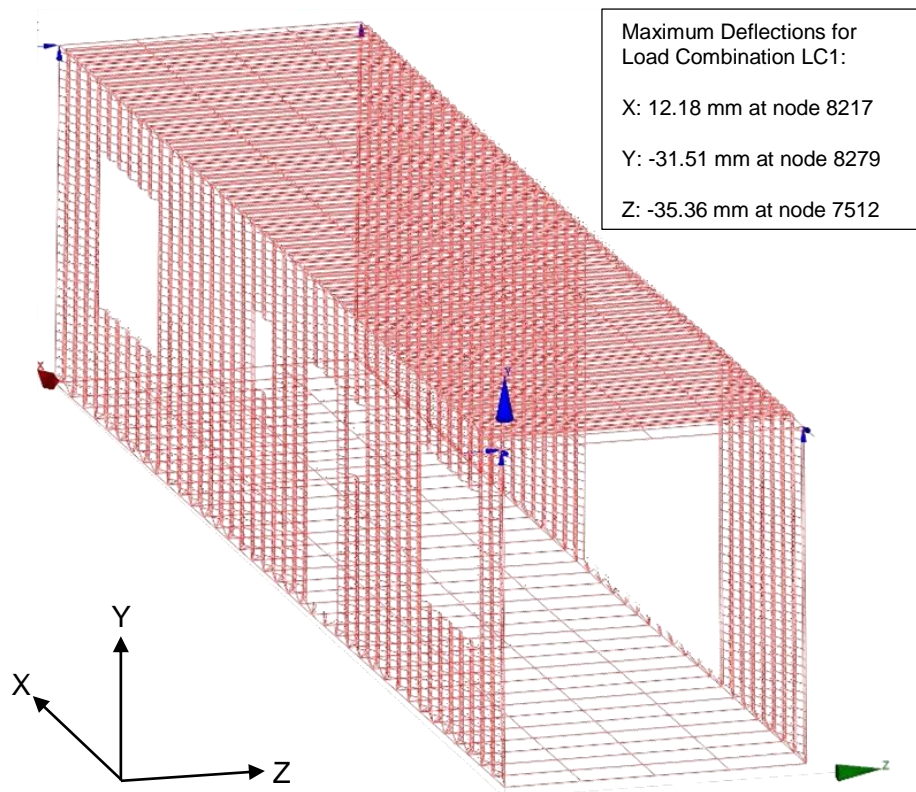
To simulate the lifting of the element (by means of a crane with a supporting chassis), the FE-model was modelled with translational-fixed supports at the top four corners of the model. The floor was modelled with a distributed imposed-load of 2 tons (for the possibility of lifting the container with equipment and materials). The self-weight of the container was also taken into account. The serviceability limit state (SLS) weighting factors for the dead-load and the imposed-load were 1.1 and 1.0 respectively. For the complete calculations and results, please refer to Annexure C. As can be seen in Figure 4.10 and Figure 4.11, the maximum deflection is 35mm in the centre of the container. According to Table C.2 of the SANS10160 loading code, the maximum deflection that a floor with visible sag may undergo is limited to

$$\frac{\text{Visible Length}}{250} = \frac{12\,000}{250} = 48\text{mm}$$

The deflection of 35mm as calculated by *Prokon* is sufficiently small. Thus, it will not result in an irreversible serviceability limit state. The structure will however need to be verified for the ultimate limit state case, for which temporary bracing elements may potentially be required.



**Figure 4.10** - FEM results for lifting case with a distributed load of 2 tons.



**Figure 4.11** - FEM deflection shape for lifting case with a distributed load of 2 tons.

#### **4.3.2.3 Finite Element Analysis Results of Static Load on ISBU-element**

The second FEM case regarded the permanent static loading of the bottom container in the multi-storey test design, without any additional strengthening of the frame. The supports were modelled as completely fixed at the four corners of the container for simplicity's sake. The loading was modelled as follows:

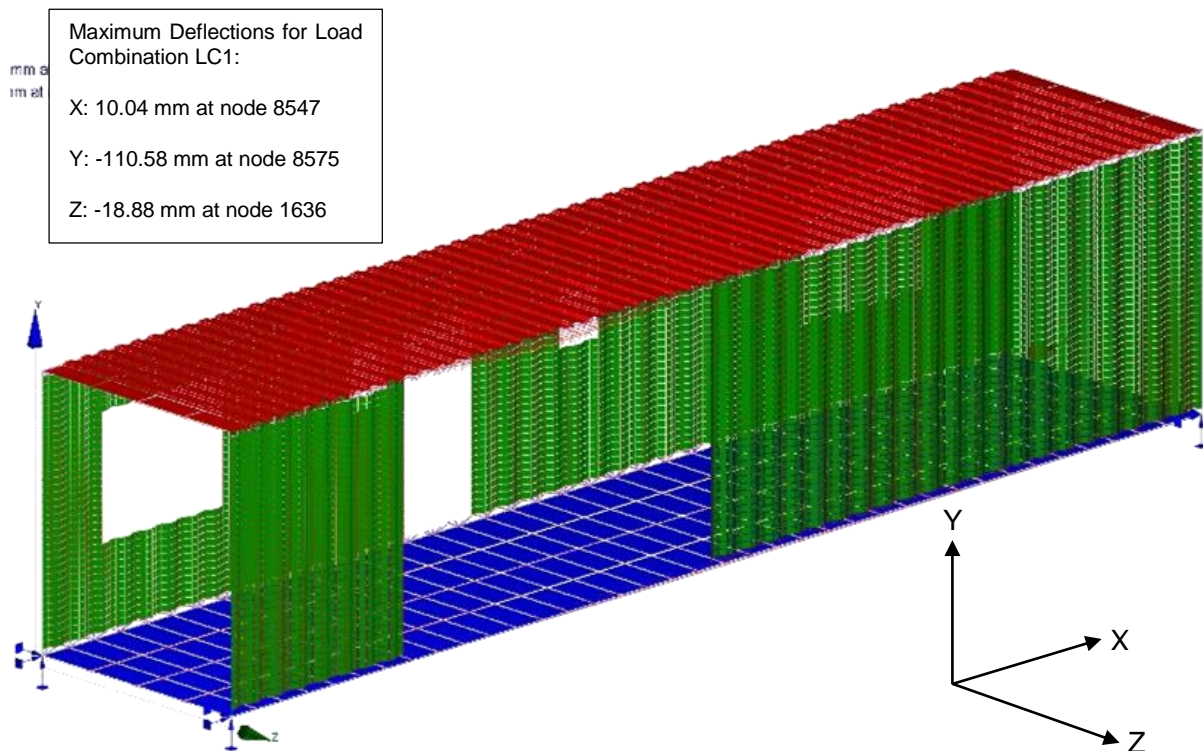
- Distributed dead-load on the roof of the container (from the concrete floor of the second container);
- Distributed imposed-load on the roof of the container (from the residents living in the second floor);
- Distributed dead-load on the internal side of the container upper beam (from the concrete slab between the containers);
- Distributed imposed-load on the internal side of the container upper beam (from the residents living on the second floor and acting on the concrete slab);
- Nodal dead-loads on the four corners of the container (from the second and third floor container, as well as the concrete floor of the third container and the roof);
- Nodal imposed-loads on the four corners of the container (from the residents living on the third floor container).



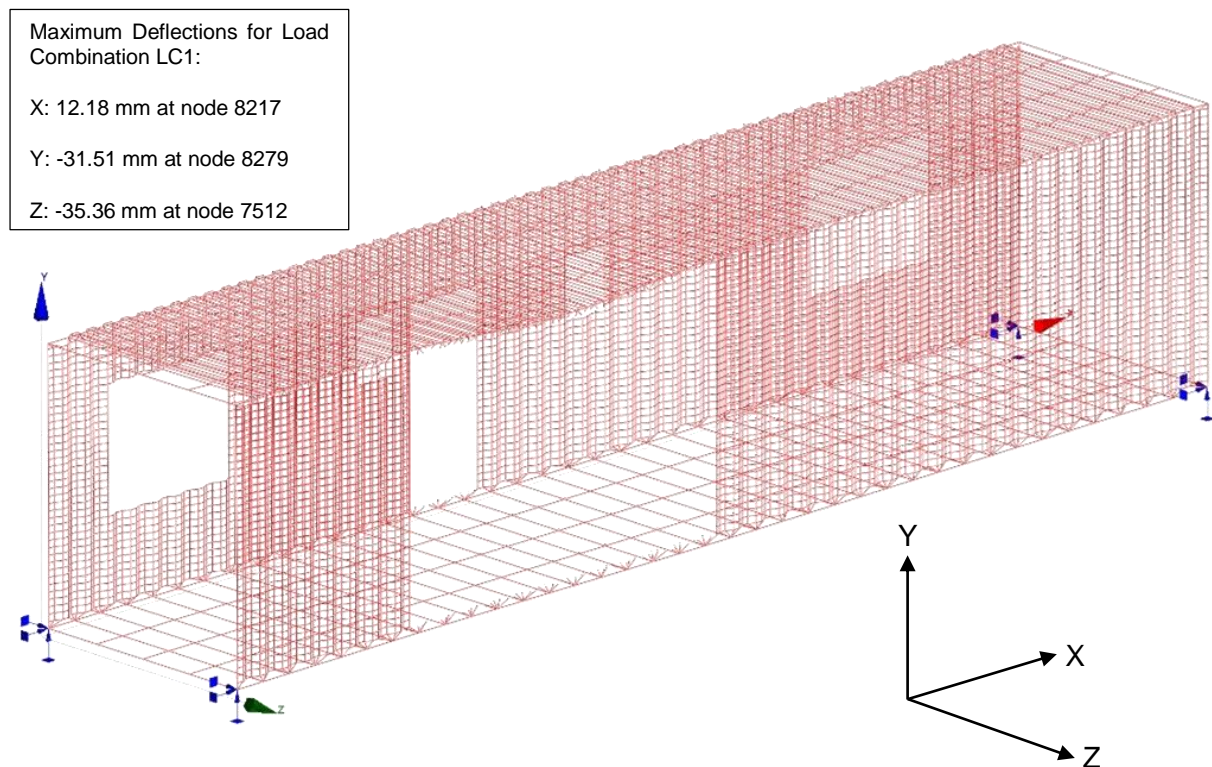
The SLS weighting factors for the dead-loads and imposed-loads were 1.1 and 1.0 respectively. For the complete calculations and results, please refer to Annexure D.

As can be seen in Figure 4.12 and Figure 4.13, the maximum deflection is 110mm in the centre of the largest cut-out opening, which is far larger than the allowed limit of 48mm. This could result in an irreversible serviceability limit state, which can permanently damage the building.

The opened frame should thus be stiffened with additional elements. Additionally, a complete structural analysis will be required for the structural design of the ISBY multi-storey building, and will need to comply with all necessary serviceability limit state and ultimate limit state conditions.



**Figure 4.12** - FEM results for static loading case.



**Figure 4.13** - FEM deflection shape for static loading case.

#### 4.3.2.4 Floors and Floor Slabs

The floor slabs situated between the containers are designed to use an EPS permanent formwork system together with reinforcing steel to form several concrete T-beams. This is based on the iKhaya Future House system, which makes extensive use of EPS profiles as permanent formwork.. See Figure 4.14 for a photo of the system.



**Figure 4.14** - EPS slab permanent formwork system.



Each container is filled with a layer of 120mm 30MPa concrete to form the floor. Twenty-seven smaller EPS panels are slid into the container chassis for cost saving measures. A ref-193 reinforcing mesh is placed between each container during the lifting process, to achieve the requirement for nominal reinforcing floors, and to allow contiguous floors (i.e. from one container, to the slab and then to the other container) during the concrete pouring phase.

### 4.3.3 Insulation, Internal Walls and Finishing

The thermal efficiency rating of a structure depends on its R-value, which is an indication of the thermal resistance of a certain component, measured in  $\text{m}^2\text{C}^\circ/\text{W}$  (Desjarlais, 2013). The higher the R-value of a component, the higher its thermal efficiency.

The SANS10400 code requires that the total R-value of the ceiling be no less than 2,7 to 3,7 dependant on location. For the purposes of the study, it will be assumed that 3,7 acts as the minimum R-value. The test case design will utilise a 100mm glass fibre mat as well as the 35mm EPS insulation on the inside of the container. The cost of the glass fibre mat will be included in the total roof truss cost. Together with the plaster coat finish, it will provide a sufficient R-value. Note that the external finish will be the container steel shell, as it is durable and weather resistant.

Regarding the walls, the minimum R-value is required to be more than 0.35 (SABS Standards Division, 2008). The rating of 35mm EPS is 1.08 (Gronloh, 2013), which is more than sufficient.

Figure 4.15 shows the EPS sheets that will be used for insulation in the test case designs, as well as the finish coating.



**Figure 4.15** - EPS sheets with wire mesh, and applied shotcrete-type coating.

#### 4.3.4 Roof

The roof will be of a Fink truss type, as welded steel upstands can be utilised instead of a complete timber roof, which may prove to be cheaper. However, the purlins will still be made of timber, and the roof sheeting will be galvanised sheet metal. Thus, the roof construction will be very similar to the conventional method.

#### 4.3.5 Foundation

The foundation for container-based buildings are essentially the same as that of a traditional house, depending on the bearing capacity of the soil, which will be determined by means of a geotechnical investigation. However, hybrid ISBU buildings can usually withstand a higher degree of differential settlement than a rigid masonry type building. This concept design will utilise a floating slab foundation supported on foundation walls such as the conventional method.

#### 4.3.6 Construction Method Statement

The construction method for a container-based solution is different from that of a conventional brick and mortar housing solution. An example of a single-storey conventional method statement would be as follows (Kennedy, 2013):

- 1) Site preparation and earthworks;
- 2) Construction of foundation;
- 3) Construction of external and internal walls, fitting of doors and windows;
- 4) Installation of services;
- 5) Roof construction and ceiling insulation fitting;
- 6) Installation of finishes, ironmongery.

The construction method statement for a multi-storey container based solution would be as follows (Hart, 2013):

- 1) Site preparation, earthworks and *container acquisition lead-time*;
- 2) *Arrival and primary fabrication of containers*;
- 3) Construction of foundation;
- 4) *Lifting procedure and floor construction*;
- 5) Installation of services;
- 6) *Internal walls, insulation and ceiling construction*;
- 7) Roof construction and ceiling insulation fitting;
- 8) Installation of finishes, ironmongery.

These method statements form part of the construction programme that are compared in Chapter 5. Note that the primary differences between the conventional and the ISBU systems are highlighted in italics.

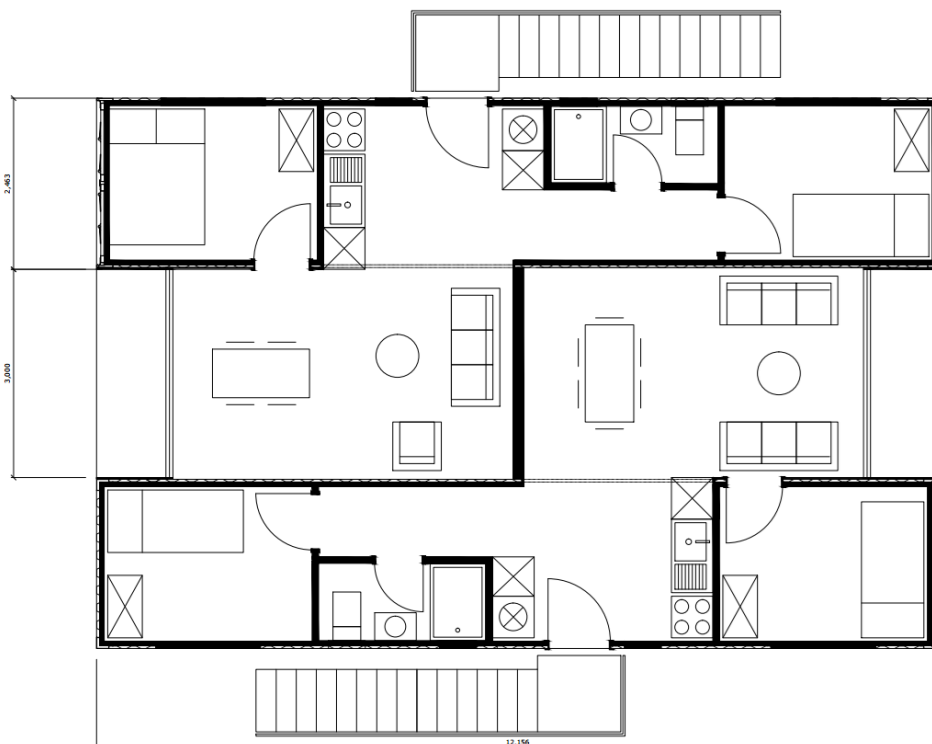
#### 4.3.7 Durability of Structure and Expected Maintenance

The high durability of the weathering steel makes a container-based solution extremely durable. In addition, the structural strength also provides high-level ruggedness to the building. Although not necessarily a scientific statement, the Inhabitat Blog reported that a category 5 cyclone (i.e. 283km/h+ wind) was unable to destroy a research station built from shipping containers in March 2006 (Yoneda, 2010).

Regarding the maintenance of the structure, it is expected that upkeep regarding building joints, outside paint and possible leaking will be the primary maintenance issues (Keuler, 2013).

#### 4.4 Final Test Case Designs for Feasibility Analysis

All the requirements and optimisations in the previous sections were followed to create two container-housing test cases: A low-density housing solution, and a medium-density housing solution. Refer to Figure 4.16 for the plan layout of the container configuration:

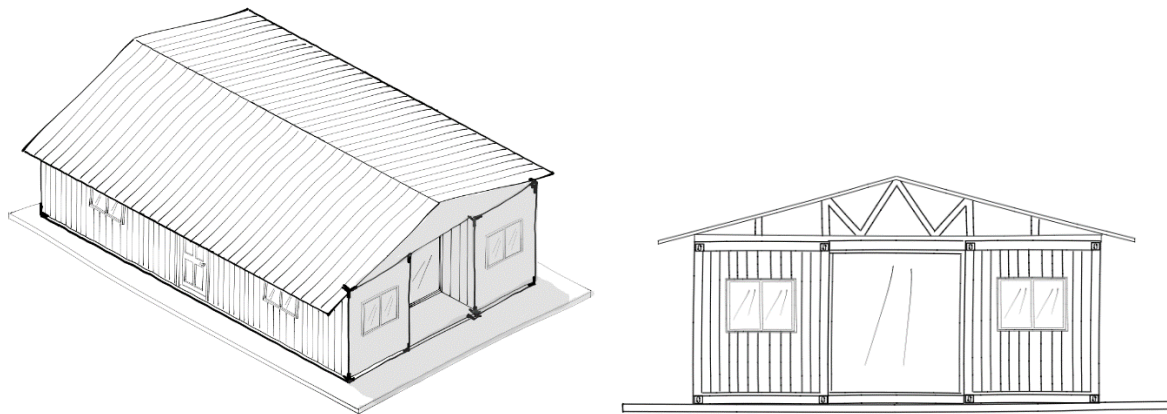


**Figure 4.16** - Plan view of test case designs.

These designs will be compared in the following chapters to equivalent conventional solutions in terms of the economic, societal and environmental parameters.

#### 4.4.1 Low-Density ISBU Housing Concept Design, Test Case 1

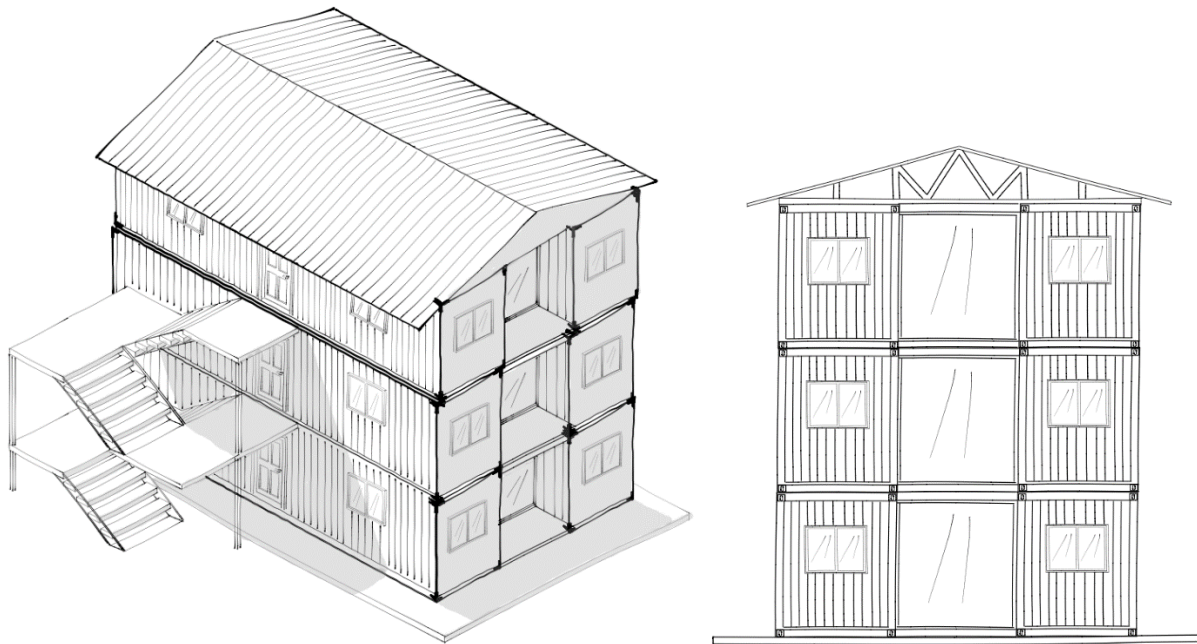
The low-density ISBU housing solution is capable of housing two families. Refer to Figure 4.17 for a visual representation of the test case:



**Figure 4.17** - Test Case 1: Single-storey, low-density ISBU Housing

#### 4.4.2 Medium-Density ISBU Housing Concept Design, Test Case 2

The medium-density ISBU housing solution is capable of housing six families in a three-storey building. Refer to Figure 4.18 for a visual representation of the test case:



**Figure 4.18** - Test Case 2: Single-storey, medium-density ISBU Housing

## 4.5 Conclusion

This chapter developed a set of requirements from the challenges presented in the literature review that formed the concept idea of a container-based house for low-cost housing. Further investigation revealed structural shortcomings of this design configuration that will need to be addressed via strengthening of load-bearing elements. The purpose of these analyses was not to find definitive answers, but to evaluate if strengthening and stiffening would potentially be required. If an ISBU based-project is planned, its strengthening will have to be determined on a case by case basis.

Finally the concept test design resulted in two feasibility candidates: a single-storey ISBU-based house, and a multi-storey ISBU-based apartment building.

The next chapter investigates and compares the test case design against a conventional brick and mortar design in terms of cost, construction time and quality of end product.

## CHAPTER 5

# COST, TIME, SUPPLY AND QUALITY ASSURANCE OF ISBU HOUSING

### 5.1 Introduction

This chapter looks at the economic comparison between ISBU housing and conventional housing. The ISBU housing concepts were developed in Chapter 4, and are expanded to include a bill of quantities for a single-storey, and a multi-storey ISBU-solution. This is compared with the current costing rates for subsidised and gap housing in South Africa per square meter obtained from several manufacturers and case studies.

In addition, a project time schedule was created for the ISBU solutions and contrasted with the average construction time of a conventional project per house/unit. Finally, a quality approach is investigated to ensure that the final product is not impacted by inadequate workmanship.

### 5.2 Case Studies

There are several isolated cases of container use in residential projects in South Africa, however most are only of a temporary nature. Since the costs and project time schedules for the test cases have been developed independently, it is useful to compare the data with that of completed local projects.

The data from three different test cases were used to source and calibrate the results of the research study and are detailed below.

#### 5.2.1 61 Countesses Ave, Windsor Park, Randburg

Michael Hart Architects designed an award-winning multi-storey residential apartment complex for Citiq Property Developers in 2012, with the use 12m and 6m intermodal steel building units. This is a unique project, as it is a first of its kind in Gauteng, and one of a few in South Africa (the Simon's Town High School Hostel also utilises ISBUs) (Open Architecture Network, 2010).

The building is three storeys high, and utilises six 12m ISBUs, and four 6m ISBUs per floor for a total of 30 ISBUs. This stacking configuration provides for 15 apartment units, each rented



out at between R3 500 and R4 200 per month (Hart, 2013). See Figure 5.1 for the concept representation of the apartment block:



**Figure 5.1** - Concept representation of 61 Countesses Ave (Hart, 2013).

### 5.2.2 Community Residential Unit Project, Cape Metropolis, Cape Town

In 2012, Aurecon acted as the consultant for the City of Cape Town for a local Community Residential Unit Refurbishment Programme. This programme entailed the refurbishment and maintenance of 7 775 identified dilapidated apartment rental units in Athlone, Elsies River, Heideveld and Ottery in the Cape Metropolis. In order to empower the community it was decided to utilise local labour as much as possible, by moving residents out of the identified apartments into a temporary housing village until reparations were complete. The residents were then moved into their newly refurbished apartments, and a new section of apartments would then follow the same procedure, until the end of the project (SAICE, 2012).

The container village utilised converted, refurbished shipping containers. Each family was allotted a two-bedroom, 12m residential container and an additional 6m container for storage of apartment contents (Keuler, 2013). See Figure 5.2 for a photo of the container village:



**Figure 5.2** - Temporary container village (Keuler, 2013).



### 5.2.3 Watergang Housing Project, Kayamandi, Stellenbosch

The Watergang Housing Project in Kayamandi, Stellenbosch is a multi-phase project initiated in 2007, and has thus far delivered 611 completed 40m<sup>2</sup> BNG houses to beneficiaries since May 2013 (Oom, 2013).

This housing project was utilised in the research of Brewis in 2012 regarding the environmental lifecycle analysis (LCA) of conventional and alternative construction. This research serves as the background to the environmental calculations of ISBUs in this study, and as the costs and quantities relate closely to the waste generation of a project (Brewis, 2012), it is deemed useful to compare the quantities of an “average” 40m<sup>2</sup> BNG house with that of an ISBU solution.

## 5.3 Manufacturer Data

The lifecycle of an ISBU starts with the ordering of a specified amount of new containers from manufacturers by large shipping lines. After a certain period, or number of uses, a shipping container will be deemed unseaworthy and thus obsolete. The shipping line can then either sell or refurbish the container to increase its useful period (H. Slawik, 2010). If the container is sold, it forms part of the supply for ISBUs in the building sector. Another method that containers contribute to the ISBU supply is by lack of shipping demand. Some countries have a net income of shipping containers (e.g. the USA receiving goods from China and not exporting the same amount of freight in return) and thus shipping lines deem it more economical to sell these containers off, rather than ship them empty (Levinson, 2006).

Several different factors will affect the price comparison between traditional homes and container-based homes. The main influencing factors are (Gronloh, 2013):

- Supply of usable containers;
- Price of new and used, refurbished containers (minimum determined by steel and scrap steel price);
- Price of traditional homes (variable according to prices of sand, cement and galvanised steel);
- Price of container transport and delivery (including crane systems).

As seen from the above factors, prices can vary greatly (due to steel and oil price variability) while the price of traditional homes can be more stable. Sand and cement prices are affected less by market fluctuations (H. Slawik, 2010).

Several manufacturers were used to gather pricing and affecting data on container acquisition, transport and conversion.

### **5.3.1 Cost of New Intermodal Freight Containers**

According to 2011 data supplied by the “Containerization International Magazine”, the pricing for new 6m high-cube freight containers in China ranges between US\$2 000/unit and US\$5 000/unit, while 12m high-cube freight containers range between US\$3 500/unit and US\$7 000/unit (World Shipping Council, 2009). With a direct conversion rate of R10 to US\$1, it is clear that the use of new containers for residential purposes fall outside the scope of low-cost housing, as a single-storey ISBU housing solution will cost a minimum of two 12m containers, and can thus range between R70 000 and R140 000 for an uninsulated, non-serviced top structure. This shows the necessity of using second-hand containers.

### **5.3.2 Shipping Companies and the Used Container Supply in South Africa**

The primary shipping lines operating in South Africa are as follows (van den Heever, 2013):

- Safmarine;
- Hamburg Sud;
- MOL;
- MSC;
- DAL;
- MACS;
- Maersk Sealand Lines;
- K-Line;
- Evergreen; and
- Hapag-Lloyd.

These companies provide the bulk of second-hand containers for ISBU conversion after the end of their useful lifecycle, by replacing their fleets with newly constructed containers. However, due to the competitive nature of the shipping industry, it is difficult to acquire the exact figures of fleet replacement for the different companies. By using data from the World Shipping Council and annual shipment figures from Transnet Port Terminals, an estimate for the container supply in South Africa is calculated in section 5.4.

### **5.3.3 Container Refurbishment**

The costing data from four local container supply and refurbishment companies were used in the research study, namely:

- Spazatiner (Cape Town);
- Fabricated Steel Manufacturing (Johannesburg);
- Containerworld (Johannesburg);
- Big Box Containers (Cape Town).

Several factors affect the pricing of used, refurbished containers. According to Fabricated Steel Manufacturing, the following aspects contribute to the cost of refurbishment (Gronloh, 2013):

- 1) *Appearance*: Rusting, dents and inadequate maintenance will require additional rework to refurbish a used container, although the quality is mostly subjective.
- 2) *Age*: Many shipping companies will start to consider selling used containers at a lifespan of 10 years, although it can range up to 15 years dependant on the physical condition of the container.
- 3) *Structural Damage*: Minor damages are common on used containers, but major structural damage may be revealed during inspection. This will alter the cost the container, as the rework may be extensive.
- 4) *Origin*: Lastly, the distance from the current location of containers to the desired delivery location also affects prices. Sourcing containers as close as possible to a project will reduce transportation costs.

After the condition of a used container has been determined via inspection, it can proceed to the refurbishing stage. Refurbishing a container consists of a 4-step process, which is as follows (Gronloh, 2013):

- Unit inspection, cleaning, decontamination and preparation for repair;
- Repairs carried out by experienced, certified boilermakers;
- Floor and door fitting;
- Repainting and inspection.

After the final inspection has been completed, the container is shipped to the customer.

#### **5.3.4 Container Transport and Erection**

The price and erection costs of containers are dependent on various fluctuating factors such as fuel costs, road levies, tolls and equipment hire. Due to this, a fixed value for transport and erection was obtained in mid-2013 from Spazatiner and Fabricated Steel Manufacturing.

### 5.3.5 ISBU Conversion

Most used containers are converted in a factory to client specifications, and thus utilise a prefabricated construction method. However, because the method used in constructing the test cases relies on on-site manufacturing, it was necessary to use manufacturer rates and adapt them to use local labour.

Rates were used from Spazatainer, Containerworld, Big Box Containers and Fabricated Steel Manufacturing.

## 5.4 Shipping Container Supply in South Africa

The World Shipping Council describes the shipping volume for ports as calculated in twenty-foot equivalents (TEU). This relates to the volume of freight that is shipped into- and out of ports with the inside volume of a 6m freight container as standard (World Shipping Council, 2009). However, data for the retirement rate for containers in South Africa are unavailable, as shipping companies do not disclose this information. Due to this, it is necessary to estimate the retirement rate per year.

According to data from the Transnet Port Terminals information website, the annual cumulative capacity of all ports in South Africa are equal to 4.9 million TEU's (Transnet, 2013). See Table 5.1 for a breakdown of port capacity in SA:

**Table 5.1** - Annual Container Capacity of SA Ports.

<b>Port of Dispatch</b>	<b>Annual Capacity</b>
Durban, Pier 1	0.7mil TEUs
Durban, Pier 2	2.1mil TEUs
Cape Town	0.9mil TEUs
Port Elizabeth	0.4mil TEUs
Ngqura	0.8mil TEUs
<b>Total</b>	<b>4.9mil TEUs</b>

(Adapted from Transnet Port Terminals Information, 2013)

In order to calculate the total container replacement of fleets in South Africa, it is assumed that the replacement rate is the same as the global average rate. According to the World Shipping Council, the annual replacement of container fleets in the world measured 5.3% of the total global fleet for 2009, and was projected to decline to 5.1% in 2013 (World Shipping Council, 2009). Thus, for an annual replacement of 5.1%, a daily replacement value would be 0.014%.

In 2010 the annual total TEUs in Transnet ports amounted to 1.9 million (Transnet, 2013). This equals a daily average of 5205 TEUs worth of cargo being imported and exported from SA ports. If one assumes a retirement probability of 0.014% for each container per day, this would equal to an average daily container retirement rate of 0.73 units. This equals 266 TEUs per year for the local market (World Shipping Council, 2009). Note that this figure is based on calculated values, and can be much higher dependant on the demand.

## 5.5 Comparison of Construction Costs and Time

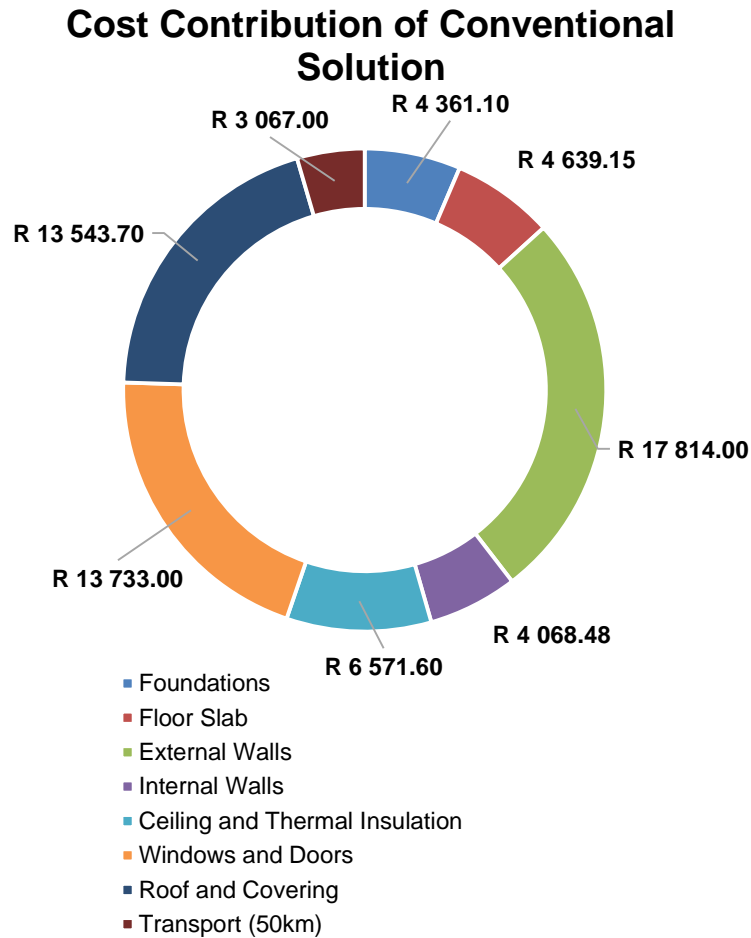
### 5.5.1 Assumptions

- Many billed quantities are equal between the ISBU and conventional solution. Thus, baths, toilets, shower sundries and built-in items such as cupboards were not part of the comparison between the conventional and ISBU solutions;
- A transport distance of 50km was assumed, at an arbitrary building location in the Western Cape;
- Transport and labour costs are included in the rates for the bills of quantities if not specifically mentioned;
- Fluctuations in pricing were ignored over the course of the project duration, and a fixed rate was applied for all items;
- Geotechnical conditions are assumed as compacted sand with a low plasticity index, and thus a nominal foundation design;
- For time estimation purposes, a lead-time of 3 days per refurbished container is assumed;
- Brewis obtained the bill of quantities of an “average” 40m<sup>2</sup> conventionally built BNG house. However, to compare this control case with that of the test cases, several alterations regarding transport distance, and the addition of windows and doors needed to be made;
- Savings due to scale of economies are not factored into results;
- The land cost is not factored into the results;
- Services are not factored into the results.

### 5.5.2 Comparison of Costs

#### 5.5.2.1 Conventional Control Case

After the cost adaption and recalculation for the conventional case, the total of each house amounts to R67 798.03 for a 40m<sup>2</sup> BNG house. Refer to Annex E for the complete bill of quantities. See Figure 5.3 for a distribution of the total cost of the house:

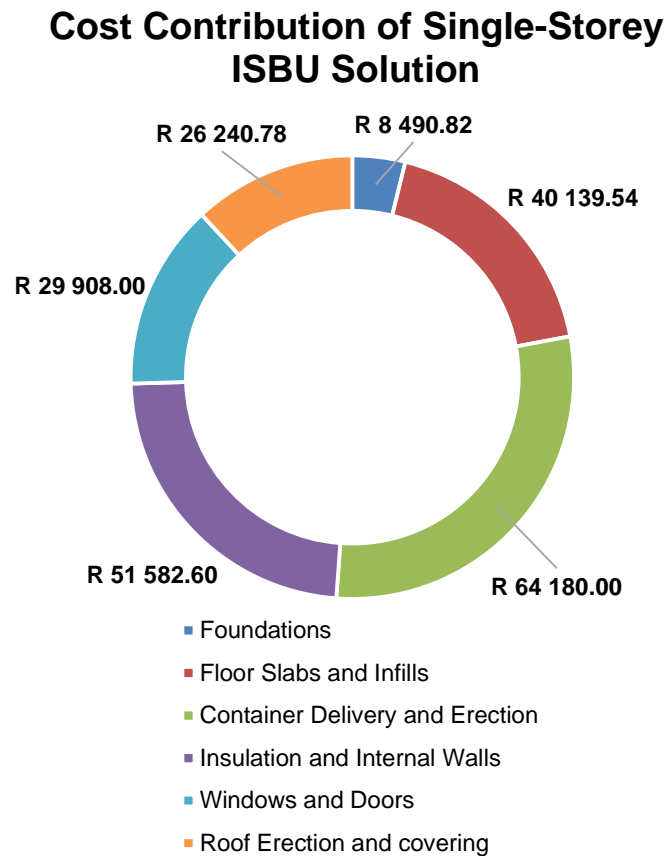


**Figure 5.3** - Cost Distribution of Conventional Control Case.

This amounts to a cost per square meter of R1 694.95, which is close to the amount advocated by the Department of Human Settlements (R1 625.00 per square meter, as discussed in the literature review).

#### 5.5.2.2 Single-storey ISBU Test Case 1

As developed in Chapter 4, the single-storey test case consists of two 12m converted steel containers, with a 3m gap in the middle that forms a third room. It is thus assumed that two households will occupy each “double-unit”, with each partitioned home having a floor area of 48m<sup>2</sup>. According to the bill of quantities the total cost of this double-unit is calculated as R110 270.87. Refer to Annex F1 for the complete bill of quantities. The cost breakdown for each constructed section is shown in Figure 5.4.



**Figure 5.4** - Cost Distribution of Single-storey Test Case 1.

With a total floor area of 96m<sup>2</sup>, the cost per square meter works out to R2 297.31, which is significantly higher than the conventional case. This can be attributed to the additional cost of insulation material, the extra transport and erection costs as well as the container costs. However, the addition of an empty space due to the hybridised design leads to a cost saving of a complete 12m container with its transport cost, which is R31 850. If this approach had not been followed, the cost per square meter would have equated to R2 960.85.

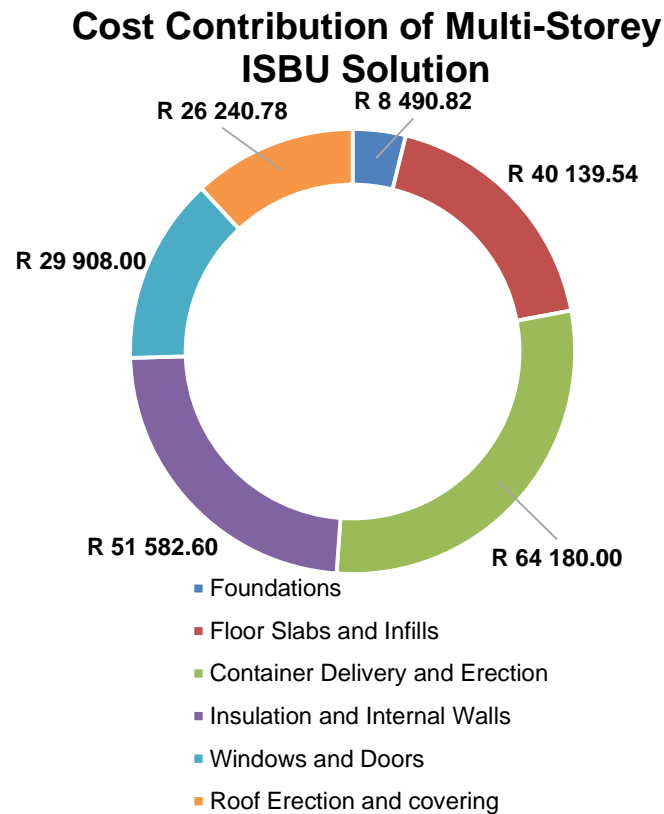
If a double-unit approach were not preferred, one would need to redesign the house with a minimum floor area of 40m<sup>2</sup>. This equates to the use of a single 12m container together with a 6m container. This configuration will result in a much higher cost, as the effective cost per square meter is much higher when utilising 6m containers. In addition, a hybridised approach would be ineffective, further negating cost savings.

### 5.5.2.3 Multi-storey ISBU Test Case 2

The multi-storey test case consists of six stacked 12m converted steel containers, with a 3m gap in the middle that forms a third room. It is assumed that two households occupy each floor, to a total of 6 floors inhabited. Each partitioned home has the same 48m<sup>2</sup> floor area as



the single-story case. According to the bill of quantities the total cost of this multi-story building is calculated as R541 881.43. Refer to Annex F2 for the complete bill of quantities. The cost breakdown for each constructed section is shown in Figure 5.5. Note that steel steps have not been added to the total cost.



**Figure 5.5** - Cost Distribution of Multi-storey Test Case 2.

The total floor area of this building is equal to 288m<sup>2</sup>, which equates to a cost per square meter of R1 881.53. This is quite close to the conventional design's cost per square meter, and compared with the single-storey test case, shows that there is a definite cost saving in expanding vertically with an ISBU based building.

A large aesthetic drawback of the test case design is the external finish of the building, which is socially unacceptable to some beneficiaries (Hart, 2013). If additional cladding and finishing were preferred, the cost of the building would increase to more than R3 000.00 per square meter.

Another drawback is the large percentage of the cost spent on transportation. The bill of quantities shows that the total cost for transport of the containers to site is R14 100 for six containers. However, as this type of design is better suited to projects located in dense areas such as a city, it is unlikely that the transport distance will equate to 50km.

### 5.5.3 Comparison of Construction Time

#### 5.5.3.1 Conventional Control Case

The Department of Human Settlements, as well as several companies note that the average construction time for a conventional house ranges between 25 to 30 days when calculated over the length of a housing project (Department of Human Settlements, 2010; Hart, 2013).

The estimated path of activities for building a conventional BNG house is as follows:

- 1) Site preparation and earthworks (2 days)
- 2) Construction of foundation (2 days);
- 3) Construction of external and internal walls, fitting of doors and windows (5 days);
- 4) Installation of services (varies);
- 5) Roof construction and ceiling insulation fitting (5 days);
- 6) Finishes, ironmongery (2 days).

Therefore, the total estimated completion time is 16 days per home.

#### 5.5.3.2 Single-storey ISBU Test Case 1

The construction method statement for a single-storey container based solution with on-site manufacturing) would be as follows, as adapted from multi-storey solution from Windsor Project (Hart, 2013):

- 1) Site preparation, earthworks and *container acquisition lead-time* (5 days);
- 2) *Arrival and primary fabrication of containers* (1 day);
- 3) Construction of foundation (1 day, overlapping with lead-time activities);
- 4) *Lifting procedure and floor construction* (1 day);
- 5) *Internal walls, insulation and ceiling construction* (3 days);
- 6) Installation of services (varies);
- 7) Roof construction and ceiling insulation fitting (2 days);
- 8) Finishes, ironmongery (2 days).

Thus, the total estimated completion time is 15 days per home. These construction times are not concrete figures as they may vary according to product delivery.

#### 5.5.3.3 Multi-storey ISBU Test Case 2

The construction of the multi-story ISBU building in Windsor Park occurred in a time period of 3 months, with a 3 month lead-time for acquiring the necessary containers. A total of 30 containers was utilised for this development. The Head Engineer of Citiq, developers of the

structure, noted that had the building been built by means of conventional methods, it would have taken around 18 months to complete (Hart, 2013). This implies that construction time can be cut to a third with the use of containers on higher-density housing. Similarly time savings have been reported by the US Army Corps of Engineers, where a multi-storey office building consisting of 101 container units was built in almost two-thirds the construction time of a conventional office building at Fort Bragg (GreenBiz News, 2008). When compared to single-storey solutions it is inferred that a savings on construction time can be achieved if ISBUs are utilised. The reason for this cost saving is as follows:

- There is no need to wait for concrete curing, as the load-bearing elements are already in place;
- The ISBUs can be stacked in a very short time, and concrete pouring operations can commence on any floor, or simultaneously on all floors.

Time savings may vary depending on the type and size of a project, however, one can assume that an economical ISBU design will be completed in less time than a conventional structure.

## 5.6 Commentary on Quality Assurance of Final Product

The Human Settlements Review conducted in 2010 regarding the slow adoption of alternative building technologies noted that *“studies conducted in both 2003 and 2010 found that within a few months of completion of construction structural defects such as gaping wall cracks, roof leaks, unstable roofs, water penetration and seepage were experienced. In some cases, houses were demolished due to shoddy workmanship. All these problems contributed to already negative perceptions of alternative building technologies which prevented large scale rollout”* (Department of Human Settlements, 2010). These studies found that a large percentage of beneficiaries view ABTs with an acute scepticism due to the view that ABT solutions are inferior to conventional designs. However, these findings do not necessarily show that the design utilised is deficient in quality, but rather that quality control measures are not properly implemented by the contractor. This also implies that the same quality deficiencies found in certain ABT projects will also be found in conventional projects.

According to a study performed by Wentzel, the reason that low-cost housing in South Africa is exhibiting such low end-product quality is due to time and budget constraints that result in a pressurised environment for contractors to execute the work, as well as the designers that produce designs based on economical budgets (Wentzel, 2010). This leads to an unsustainable environment where the high pressures exacted by the client (i.e. local government) lead to low quality housing. Therefore, in order to obtain a high quality product, it must be ensured that a proper quality plan is in place. Standard practice advocates the use

of ISO9001 quality control procedures, inspected and approved by all parties before project commencement. The correct enforcement of this quality plan will determine the end-product quality to a large extent (Nicholas & Steyn, 2008).

## 5.7 Conclusion

In summary, a cost evaluation was done for a conventional low-cost house design, a single-storey low-cost design utilising ISBUs and a multi-storey low-cost house design utilising ISBUs. Refer to Table 5.2 for the summarised cost per square meter of each design. The results show that no cost savings can be achieved when utilising a single-storey ISBU solution. However, the use of ISBUs in a multi-storey design shows a saving of R415.78 per square meter, compared to a single-storey ISBU and a close match to the conventional method of construction. The optimisation of the design may lead to further cost savings.

**Table 5.2** - Summarised cost for each case.

Case	Cost/m <sup>2</sup>
Conventional	R 1 694.95
Single-storey ISBU	R 2 297.31
Multi-storey ISBU	R 1 881.53

Regarding the time aspect, it was estimated that single-storey ISBU's can result in a saving of 11% compared to a conventional solution. However, when comparing the multi-storey ISBU solution to a conventional multi-storey solution, the construction time is reduced to between a third and two-thirds of the total time. This shows that although an ISBU design may not be feasible on financial grounds, it can prove feasible in terms of construction time.

An estimation on the available container supply for building projects was made based on annual shipment figures from South African port authorities, as well as the average container replacement values as determined from the World Shipping Council. It is estimated that at least 266 containers are available per year for refurbishment and upcycling.

Lastly, the effect of quality on ABT's was investigated. Previous research has shown that low quality of delivered low-cost housing is primarily due to a lack of adherence to a quality plan by contractors and consultants. Thus, the effect on quality due to design is considered marginal in comparison.

## CHAPTER 6

# SOCIAL ACCEPTANCE OF ISBU HOUSING

### 6.1 Introduction

This chapter investigates the social acceptance factor regarding acceptance by beneficiaries of an ISBU low-cost house, compared to a standard brick and mortar “Breaking New Ground” (BNG) house. The background to societal housing needs and preferences are investigated and a scientific survey developed according to these principles to measure community opinion on Alternative Building Technology (ABT) feasibility. The survey was performed via door-to-door interviews in a rural informal settlement in Caledon, Western Cape, South Africa. In this chapter, survey results are evaluated and the feasibility of the test cases are discussed.

### 6.2 Negative Perception of Alternative Housing Solutions

Even though several alternative housing designs have been proposed, tested and built as showcase examples by a variety of organisations in South Africa, the uptake of such solutions have not progressed to implementation on a massive, nationwide scale. The negligible 0.68% share that make up the total of low-cost alternative housing projects in South Africa illustrates this situation. Negative perceptions that prospective homeowners have about new building materials and technologies contribute to this sector’s exclusion, and community input has shown this to be a widespread problem (Department of Human Settlements, 2010). Thus, the underestimation of the complex relationship between society and housing in the alternative low-cost housing sector is evident.

The proposed test designs in this thesis are subject to the “Alternative Building Technology” moniker (ABT) due to the use of repurposed shipping containers. Since most rudimentary homes in informal settlements make use of corrugated metal sheeting, some residents may strongly object to the use of steel containers in government-subsidised housing (the argument being that the government are moving the residents from “tin houses” to “fancy tin houses”) (Gronloh, 2013). This objection stems from the sociological view of a traditional “home”. From the general viewpoint of the beneficiaries, a traditional home consists of a brick and mortar top structure with adequate living space, kitchen, ablution facilities and bedrooms, together with a back- and front yard. The solidity provided by modern brick structures contributes to inhabitants feeling safe and comfortable inside their homes, as opposed to the perceived lower

quality of ABT systems (which make use of thin steel frames and panelling, variations of lightweight aerated concrete, or polystyrene coated with thin plaster to name a few examples).

Thus, the unfamiliarity of alternative construction systems lead to scepticism against these technologies, due to inhabitants not understanding the full extent of what a new system entails. Beneficiaries view solutions, making use of alternative building technologies, as an inferior product, and thus believe they are devalued citizens by the state. This unfamiliarity is due to ineffective public participation and community feedback, as well as insufficient marketing of ABT homes, according to several shareholders in the built environment (Gronloh, 2013).

### **6.3 Survey Investigation of Negative ABT Perception**

To determine an accurate sociological view of acceptable low-cost homes from residents living in formal and informal houses, as well as measuring the effect that marketing has on ABT acceptability, it was necessary to conduct a sociological survey. This survey aimed to obtain the unbiased opinions of residents regarding traditional brick and mortar construction versus ISBU homes. More specifically the survey investigated the opinion on two contrasting test cases: A traditionally built single-storey house according to BNG policy specifications, and an alternative single-storey house using repurposed shipping containers as building modules. These two cases are identical to the feasible single-storey test and control solution as developed in Chapter 4.

In addition, the research also aimed to simulate the effect of public participation and marketing in the alternative housing sector. This is achieved by presenting the survey in three different parts:

The first part aimed to obtain the uninformed opinion of the participants regarding preference between the two survey cases, with no information pertaining to the technical performance of the two types of houses, thus providing an uninformed opinion. The second part of the survey provided the participants with various real-world technical information e.g. the durability, thermal performance, cost, construction time, etc. regarding the two cases. Therefore, the preferences between the houses were examined once more, but the participant was then presented with more accurate information in order to obtain an informed opinion. The third and final part of the survey determined whether the participant was willing to accept the container solution, if some aspects of the traditional solution were present. This provided an informed, investigated opinion from the participant as the conclusion to the survey.

The survey method was by means of verbal interview of individual homeowners. Assistants, each one trained and reviewed by the researcher, carried out each interview. Five assistants

were used to complete the survey in the allotted time, and were chosen from the local population, as they had the necessary language proficiency and cultural understanding to communicate with the local residents.

The importance of this study regarding the feasibility of a container-based housing solution is important, as the beneficiaries' preferences determine the widespread social acceptance of feasible ABT homes in South Africa's national housing supply, and thus the resulting economic and social stability produced through owners' satisfaction.

## 6.4 The Social Aspects of Housing

To develop a scientific social survey that presents useful data, one needs to understand the needs of people related to housing. The relationship between housing and society is quite complex, and comprises a widely studied field in the areas of consumer science and human sociology. According to Shi, the most studied terms in this field are housing needs, wants, values, norms, preferences, satisfaction and acceptability (Shi, 2005, p. 12). From the collection of previous research one can condense the most important social aspects into 3 primary categories, namely:

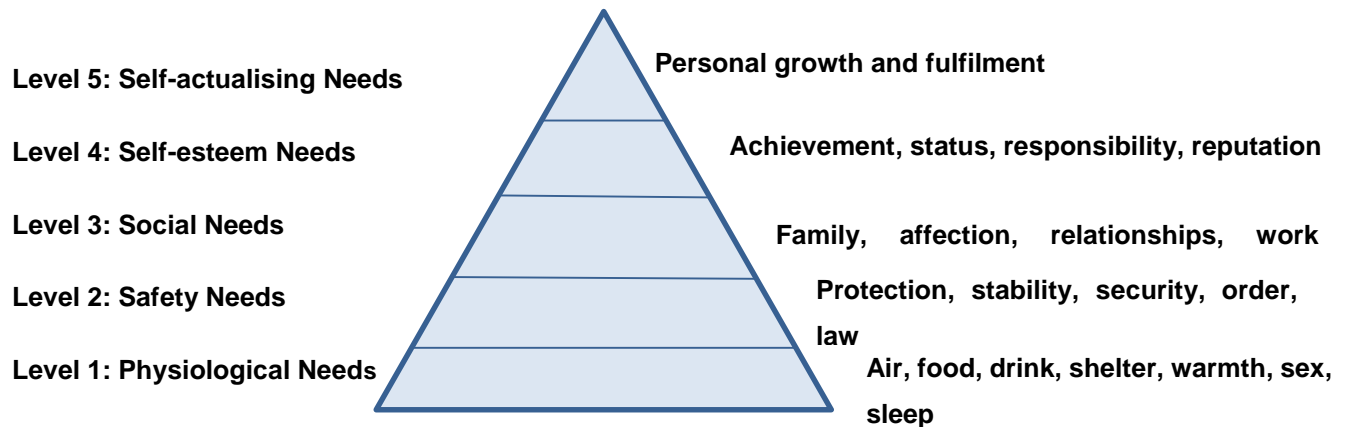
- Housing Needs;
- Housing Norms; and
- Housing Preferences.

These primary aspects determine the social acceptability of a house. The following section will discuss the extent and importance of each housing aspect, as well as the contextual relevance to informal housing communities in South Africa and the development of a scientific survey.

### 6.4.1 Housing Needs

Maslow's framework, which is famously portrayed as a triangular hierarchy of levels, postulates that the needs of human beings can be divided into several different layers of importance. This hierarchy of needs was developed by Abraham Maslow in 1943 in his quest to qualify the theory of human motivation (Simons, et al., 1987). Although his research has been superseded by modern Attachment Theory in sociological and psychological research (which only considers the nature of long-term relationships between humans), its core concept still proves valid for the definition of basic human housing needs. See Figure 6.1 for an interpreted, graphical depiction of Maslow's hierarchy:





**Figure 6.1** - Maslow's Hierarchy of human needs

According to the definition as set out by Maslow, the needs of humans can be divided into 5 different layers, with each layer taking precedence before the other layers. Referring to Figure 6.1, the first level pertains to basic physiological needs which are the lowest ranked level in the hierarchy. From here all other levels originate, up to the fifth level. If a level's need has not been addressed then the upper levels' influence are unimportant; thus, each level must be fulfilled to progress to the next. Although this hierarchy was developed to encompass the whole of human needs, it can be narrowed down to a definition that only addresses needs directly related to housing.

The first level addresses the most basic of human needs. Housing is critical at this level, as the need for shelter and warmth by humans is inherent to their survival. The second level reflects the need for a safe, stable and secure environment for humans, which is provided by means of a house. The third level relates to the social component of humans, such as family and relationships. Housing needs cannot be directly narrowed down at this level, but the secondary impacts of housing (e.g. your family living close to your house) do play a role.

At the fourth level of the hierarchy a house is a display of a person's social status and self-achievement. Thus the social component of housing is relevant at this level of personal needs. The fifth and final level of needs is the personal growth and ultimate self-fulfilment of the owner. At this level the personalisation of a home by the owner exists as a means of individualisation and self-expression. The final two levels of human needs describe the self-esteem and self-actualising of owners, and should not be disregarded by the investigation in terms of housing.

Therefore, according to Maslow, the needs of humans in terms of housing are primarily physiological, with secondary importance being placed on the social and self needs provided by benefit of having a house. This also implies that these basic needs can be considered the cornerstone of all other miscellaneous needs, with little to no variance between different humans. They are also time-independent, as these basic needs will not vary or change

significantly over a period of time. Note that Maslow's Hierarchy have been criticised on the grounds of cultural specificity, although the underlying principle still applies in general for the purposes of this study.

#### 6.4.2 Housing Norms

Even though a house may fulfil the needs of the owner, it does not necessarily mean that it will be acceptable to him/her. This is due to the cultural expectation that is present in each person. To understand this complicated facet of housing, especially as it relates to government subsidised low-cost housing in South Africa, it is necessary to investigate the extent of housing norms in all humans.

A norm is defined by the *Dictionary of English Usage* (1994) as a "a principle of right action binding upon the members of a group and serving to guide, control, or regulate proper and acceptable behaviour" (Merriam-Webster Inc., 1994). This implies that each person subscribes to a certain minimum standard of acceptability, as defined by the cultural group to which that person subscribes. The combined term "cultural group" was defined by Herodotus of Ancient Greece as a group of people sharing either descent, language, religion or customs of a given people in a given period, which differs from those of other groups.

As described by Morris et al (1986), the housing norms of people are the social peer pressures that act on households to adhere to certain standards and expectations within a community, or segment of that community. This implies that if a household does not comply with these norms, a deficit will exist. In turn it will spur the family on to remove this deficit, so as to remove the dissatisfaction of not meeting the norms. The household will then have a choice to either adjust its conditions (by changing the housing) or to adapt to the conditions (by changing the household) to remove this deficit. By incorporating the housing norms of a household, Morris and Winter then developed a new type of housing suitability approach, known as the Housing Adjustment Model (Morris & Winter, 1978).

This deficit-based suitability approach is dependent on the different types of norms that are defined by the community. In their research, Morris and Winter identified three primary- and three secondary types of housing norms. The three **primary types of housing norms** are:

- Tenure norms (ownership or renting of housing);
- Space norms (amount and types of space desired by families);
- Top structure norms (single-storey house vs. flat in apartment block).

These three housing norms are mostly the same for differing communities, as most people aspire to the same type of house, namely a single-storey brick and mortar home with enough

space for all occupants. They can also be viewed as consistent over short periods of time, as cultural norms tend to resist rapid change in communities. However, the three **secondary types of housing norms** are more subjective, and can differ between households. They are:

- Quality norms (top structure quality, amenities quality and state of maintenance);
- Location norms (as a site, as a physical environment and as a social environment);
- Expenditure norms (affordability of the housing).

Although the secondary types of household norms can be considered as subjective, they can still be seen as a subset of households in the larger community.

It must also be noted that even though some houses differ from the community norms, it should not be ascribed to a failure of adherence, but rather the presence of constraints. These barriers can manifest as economic, social or political constraints, and thus prevent a family from properly addressing their deficit in terms of cultural norms.

### 6.4.3 Housing Preferences

The preferences of a house owner are the desire for certain elements in a house, and are usually quite varied and prone to change over time. It is dependent on a multitude of aspects, which can be divided into a person's **socio-economic profile**, his **socio-demographic profile** and his **housing values**. Shi notes that a multitude of factors determines a homeowners personal preference, and notes them as follows (Shi, 2005):

- 1) Personal characteristics of residences;
- 2) Structure type;
- 3) Income level;
- 4) Education level;
- 5) Occupation;
- 6) Tenure status;
- 7) Household size;
- 8) Age;
- 9) Sex;
- 10) Marital status.

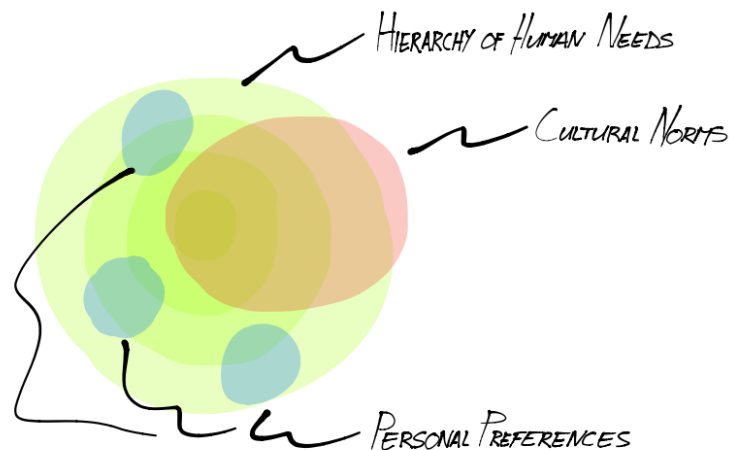
This confirms the varied nature of preferences concerning housing.

#### 6.4.4 Relationship between Needs, Norms and Preferences

The relationship between housing needs, housing norms and housing preference are quite complex. Through the background on the social aspects of housing, one can deduce the following:

- 1) Human needs are absolutes, and encompass all possible desires that humans strive towards to achieve ultimate fulfilment. People will always strive to better their living conditions in terms of housing needs.
- 2) Cultural norms are values that are dictated by a group of people sharing a similar heritage, language or view. In terms of housing, these norms may dictate a certain level of “acceptable” standards, toward which all people in the group will strive to achieve. However, this still falls within the boundaries of all human needs, but it does set minimum acceptable boundaries.
- 3) Personal preferences relate to a complex interaction between a person’s socio-economic profile, his/hers socio-demographic profile and personal housing values. These factors determine the significantly varied and short-lived preferences that homeowners may have. However, these values may be outside the reach of culturally accepted norms, but will still fall within the context of all human needs.

See Figure 6.2 for a graphical Venn-diagram representation of these relationships.



**Figure 6.2** - Relationships between Human Needs, Human Norms and Human Preferences regarding housing.

This confirms the aversion that beneficiaries have towards ABTs. Although some alternative technologies offer houses with more advantages than conventional housing, it does not

guarantee that homeowners will accept it. This is mainly due to the cultural norm of “owning a brick house”, although personal preferences may play a role for some individuals.

However, if an ABT looked conventional, and it provided better attributes than a conventional home, would it satisfy the needs and preferences of beneficiaries? This primary question will be answered in this survey.

## **6.5 Survey Methodology**

This section discusses the specific objectives of the survey, the design of the questionnaire, the interlinked variables that will affect the outcome of the survey, specifics of the survey assistants, the location of the survey and respondent particulars.

### **6.5.1 Objectives**

This survey is part of the societal parameter needed to test the feasibility of ISBU-based residential development in the affordable housing sector against the conventional method of building houses. The survey aims to:

- Determine the community's view of container-based alternative homes versus conventional brick and mortar homes on multiple aspects; and
- Determine if beneficiary preferences can be swayed if the design caters for cultural norms.

It proved valuable to gain background knowledge on the inhabitants, due to the relative infancy of the informal settlement where the survey was performed. Local government supported this, as the information could prove to be useful for future projects.

Additionally, due to the rural nature of the settlement, it was impractical to investigate medium-density housing solutions as it falls outside the reference framework of the beneficiaries. Thus, it was decided that only the ISBU-based single-storey test case would be compared with its conventional counterpart.

### **6.5.2 Survey Questionnaire Design**

The questionnaire is divided into three sections: the profile of the respondent, the respondents' housing preferences based on uninformed opinion, and their preferences based on more accurate information. The profile of the respondent ascertains the current household inhabitants' social and financial situation. The uninformed housing preferences determine the inhabitants' view of an ISBU home when compared to a conventional home. The third section provides the respondent with information regarding the physical attributes of the ISBU and

conventional home. The respondent then provides his/her opinion and concludes whether their preference can be changed if the ISBU home looked like a conventional home. Therefore, the dependant variables that are studied in the survey are:

- 1) Housing preferences of the inhabitants;
- 2) Social view of traditional brick and mortar homes;
- 3) Social view of alternative container-based homes.

The following sections provide the sequence of the survey, which consist of three different sections. The physical question and answer sheets are given in Annexure G.

#### **6.5.2.1 Part 1: Respondent Profile**

This first part of the survey aimed to obtain the socio-demographic and socio-economic profile of the respondent. This information provided a valuable background to the population mean, as well as the relation to the respondent's preferences. The interviewer asked information regarding the:

- Age of homeowner;
- Race of homeowner;
- Religion of homeowner;
- Marital status;
- Current home inhabitants (children, friends, other family dependants);
- Education level;
- Work status/Occupation;
- Income level;
- Type and size of current house;
- Mode of travel to work/school.

#### **6.5.2.2 Part 2: Opinion of ISBU versus Conventional Housing**

The second part of the survey gathered the opinion of the respondent with no influence from the interviewer. A series of pictures of the test case ISBU home and the control case conventional home were shown to the respondent. These pictures relate to generic examples of designs found in the market. The respondent then chose which picture he/she preferred. It should be noted that the pictures contained different graphics, furniture and colours. This may affect the answer of the respondent. However, the interviewer was tasked to inform the respondent that these should play no part in their choice.. The pictures that were used in this question are provided in Annexure H. They were allowed to answer either for Case A (the

conventional home), for Case B (the ISBU home), for both or for none. The first set of questions relate to the inside and outside appearance of the homes. They obtained the visual preferences of the respondent, and were as follows:

- Bedroom preference;
- Bathroom preference;
- Living room preference;
- Bedroom preference;
- Kitchen preference;
- Home layout preference;
- Outside appearance preference;
- Overall preference.

The second set of questions relate to the physical attributes of each home. The respondent answered which case he/she thinks will perform best on each attribute. The attributes were derived from the requirements set out in the SANS 10400 codes of practice, as well as general considerations that were deemed important for housing. The attributes tested were as follows:

- Spatial perception of size;
- Heat retention;
- Moisture resistance;
- Acoustic performance;
- Fire risk;
- Security;
- Durability;
- Rigidity;
- Workmanship;
- Construction time;
- Modularity;
- Inside appearance;
- Outside appearance.

### **6.5.2.3 Part 3: Opinion of ISBU versus Conventional Housing with Perfect Information**

The final part of the survey investigated whether the respondent based his/her preferences primarily on the physical attributes of the home, or on the visual appearance. After providing the respondent with an information sheet that provides the true attributes of the two test cases



(with advantages and disadvantages of each building technology), the following aspects were investigated:

- Preference based on appearance;
- Preference based on attributes;
- If the visual appearance of the ISBU house was similar to that of a conventional house, would the beneficiary prefer it?

### **6.5.3 Interviewing and Training of Assistants**

Before the survey was conducted, 25 applicants were interviewed to be used as assistants to perform the interviews. After a lengthy process, five were chosen based on their writing and communication skills, comprehension of tasks, their cultural knowledge and their enthusiasm for the project. After the selection process, each assistant attended a training session conducted by the author. It lasted for two days and informed the assistants of the purpose of the survey, the procedures to be followed, expected performance from each assistant and the importance of conducting the survey in such a manner that the results were not biased (by preventing response bias and interviewer effects). After the first phase of the survey had been completed, each assistant's papers were checked for common errors. An information session on the next day aimed to correct these mistakes in the group.

### **6.5.4 Location and Size of Survey**

In order to obtain the opinion of people living in an informal settlement, it was necessary to conduct door-to-door interviews of households. The chosen location for the survey pilot and execution phase was a recently developed rural informal settlement near Caledon, Western Cape, South Africa. This residential area expanded rapidly without the necessary approval, zoning or provision of basic infrastructure by the local Theewaterskloof Municipality in mid-2012, and has grown to over 570 separate households since April 2013 (Keuler, 2013). This number has been officially verified by the municipality at the time of writing and acts as the size of the population pool.

To reduce the sampling error of the survey, the number of survey participants needed to be large enough. To determine the size of the sampling pool, the Cochran proportion formula was used, which is as follows (Cochran, 1963) (Montgomery & Runger, 2007):

$$n_0 = \frac{Z^2 p(1-p)}{d^2} \quad (6.1)$$

Where,

$n_0$  = sample size

$Z$  = abscissa of the area of a normally distributed curve that cuts off an area  $\alpha$

$p$  = percentage of sample with an attribute present (50% = maximum variability)

$d$  = margin of error

Additionally, one can use a correction factor to decrease the sample size for small, finite populations (i.e. less than  $n = 1000$ ). This is calculated from the following formula (Cochran, 1963) :

$$n = \frac{n_0}{1 + \frac{(n_0 - 1)}{N}} \quad (6.2)$$

Where,

$n$  = adjusted sample size

$n_0$  = sample size

$N$  = population size

To calculate the sampling size, the population size was chosen as  $N = 570$ . A  $Z$ -value of 1.96 is obtained by using the tabulated values for a standard normal distribution with a confidence level of 95%. Maximum variability was desired and thus  $p = 50\%$ . The margin of error was chosen as  $d = 100 - 95\% = 5\%$ . From equations (6.1) and (6.2) the sample size was calculated as  $n = 229.7 \approx 230$  houses.

Due to the high response rate that is inherent to face-to-face surveys, the author decided to survey a total of 240 houses. This provided leeway for 10 faulty survey questionnaires.

### 6.5.5 Selection of Respondents

The purpose of the door-to-door interviewing method was to engage with the homeowners living in substandard conditions. This survey method proved to be successful as residents were very friendly and willing to provide their opinion. Each interviewer was tasked to only engage with the homeowner, as the opinion of other inhabitants could result in a bias. Each house was chosen completely at random, and interviewed if the homeowner was present.

## 6.6 Survey Results and Discussion

A total of 231 houses were surveyed within 4 days in the designated area, with a successful return rate of 96.3%. This section discusses the results that were obtained by the interviewers. Please refer to the following annexes for additional data:

**Annexure G:** Survey Questionnaire

**Annexure H:** Survey Photosheets

**Annexure I:** Survey Information Sheets

### 6.6.1 Respondent Profile

#### 6.6.1.1 Socio-demographic Profile of Respondents

The socio-demographic profile of the respondents was obtained with the intent of determining the properties of the majority of inhabitants of the informal settlement. It was also conducted at the request of the local Theewaterskloof Municipality, as the data could prove useful to future housing projects.

Table 6.1 details the age of the respondents. One can see that the majority of the population are young, with 64.9% of the population falling into the under-30 category.

**Table 6.1** - Age distribution of respondents.

<b>Age Distribution</b>	<b>Count</b>	<b>Percent</b>
19-20 years	5	2.2%
21-30 years	74	32.0%
31-40 years	71	30.7%
41-50 years	50	21.5%
51-60 years	16	7.0%
61-70 years	10	4.4%
71-80 years	4	1.8%
80+ years	1	0.4%
<b>Total</b>	<b>231</b>	<b>100.0%</b>

Table 6.2 provides the race distribution of the respondents. A majority of 59.3% of the population is of Black African descent, with Coloured people taking up a little more than a third of the share of the settlement.

**Table 6.2** - Population distribution of respondents.

<b>Population distribution</b>	Count	Percent
Coloured	89	38.5%
Black	137	59.3%
White	1	0.4%
Indian/Asian	0	0.0%
Other	4	1.7%
<b>Total</b>	<b>231</b>	<b>100.0%</b>

Table 6.3 outlines the religious affiliation in the community, with an overwhelming majority of 96.1% being Christian.

**Table 6.3** - Religious distribution of respondents.

<b>Religious distribution</b>	Count	Percent
Christian	222	96.1%
Muslim	0	0.0%
Atheist	1	0.4%
Other	8	3.5%
<b>Total</b>	<b>231</b>	<b>100.0%</b>

Table 6.4 details the marital status of the 231 respondents. A surprising minority of people are either single or living together, which shows a very high rate of marriage under young people, as well as a high divorce rate.

**Table 6.4** - Marital status distribution of respondents.

<b>Marital Status</b>	Count	Percent
Married	95	41.1%
Widowed	56	24.2%
Divorced	65	28.1%
Single	3	1.3%
Living together	12	5.2%
<b>Total</b>	<b>231</b>	<b>100.0%</b>

Table 6.5, 6.6 and 6.7 details the distribution of additional people living together with homeowners. It is interesting to note that two houses had more than 14 people living in a 2-bedroom brick house when interviewed by the assistants.

**Table 6.5** - Number of children per household.

Number of children per household	Count	Percent
0	55	23.8%
1	94	40.7%
2	44	19.0%
3	26	11.3%
4	10	4.3%
4+	2	0.9%
<b>Total</b>	<b>231</b>	<b>100.0%</b>

**Table 6.6** - Number of other family living with household.

Other family per household	Count	Percent
0	71	30.7%
1	118	51.1%
2	23	10.0%
3	12	5.2%
4	3	1.3%
4+	4	1.7%
<b>Total</b>	<b>231</b>	<b>100.0%</b>

**Table 6.7** - Number of friends living with household.

Friends living with household	Count	Percent
0	172	74.5%
1	29	12.6%
2	12	5.2%
3	11	4.8%
4	4	1.7%
4+	3	1.3%
<b>Total</b>	<b>231</b>	<b>100.0%</b>

### 6.6.1.2 Socio-economic Profile of Respondents

The socio-economic profile of the respondents show the economic welfare of the community, in terms of employment rate, income values, transportation methods and education level.

Table 6.8 shows with the education level of the respondents, with an alarming 10.8% not having a formal education, while 47.2% have completed and obtained their High School Certificate (which is equivalent to attending school until Grade 10).

**Table 6.8** - Education level of respondents

<b>Education level</b>	<b>Count</b>	<b>Percent</b>
No schooling	25	10.8%
Primary	59	25.5%
High School (Gr.10)	109	47.2%
Matric (Gr.12)	32	13.9%
Tertiary	6	2.6%
<b>Total</b>	<b>231</b>	<b>100.0%</b>

Table 6.9 details the work status of the people living in the informal community. As expected, a majority is unemployed and have to make use of grants to sustain their families.

**Table 6.9** - Work status of respondents.

<b>Occupational status</b>	<b>Count</b>	<b>Percent</b>
No employment	126	54.5%
1 job	98	42.4%
2 jobs	7	3.0%
<b>Total</b>	<b>231</b>	<b>100.0%</b>

Table 6.10 shows that 84.9% of the people in the informal settlement fall into the subsidy housing market sector, with a monthly income of less than R3 500. This is expected, as a low-income drives people towards informal settlements.

**Table 6.10** - Income level per month of respondents.

<b>Income level (per month)</b>	<b>Count</b>	<b>Percent</b>
0 to R800	97	42.0%
R8 00 to R3 500	99	42.9%
R3 500 to R5 000	26	11.3%
R5 000 to R6 500	5	2.2%
R6 500 to 8000	1	0.4%
R8 000 to R9 500	1	0.4%
R9 500 to R10 500	1	0.4%
R10 500+	1	0.4%
<b>Total</b>	<b>231</b>	<b>100.0%</b>

Table 6.11 details the types of houses in the community. Due to the nature of the settlement, a high majority consists of shacks.

**Table 6.11** - Housing types distribution.

Type of dwelling	Count	Percent
Shack	188	81.4%
1 Bedroom house	24	10.4%
2 Bedroom house	16	6.9%
3+ Bedroom house	3	1.3%
<b>Total</b>	<b>231</b>	<b>100.0%</b>

Table 6.12 shows the main method of travel being by foot. As Caledon is a rural community, one can easily travel a short distance to the central town or to one's workplace by foot, in stark contrast with the travel required in the cities.

**Table 6.12** - Mode of travel to work for respondents.

Mode of Travel	Count	Percent
Foot	195	84.4%
Bicycle	4	1.7%
Car	13	5.6%
Taxi	11	4.8%
Other	8	3.5%
<b>Total</b>	<b>231</b>	<b>100.0%</b>

## 6.6.2 Uninformed Preference for ISBU or Conventional Housing

### 6.6.2.1 Visual Preference (Uninformed)

The second part of the survey attempted to obtain the unbiased, uninformed opinion from the respondent regarding his/her view of alternative building technologies. Two construction technologies were compared in this section: A conventional brick and mortar house (Case A) and a container-based ISBU house (Case B). The respondent was shown two photos relating to an attribute side-by-side, and the interviewer gave them a short description of what was being presented in each photo. This description was carefully presented in a manner that precluded response bias from the respondent. Thereafter the respondent provided an answer on which photo he/she preferred to the interviewer. The choice of answers for each question were either a preference for

- Case **A**;
- Case **B**;
- Case **A&B**; or
- **None**.

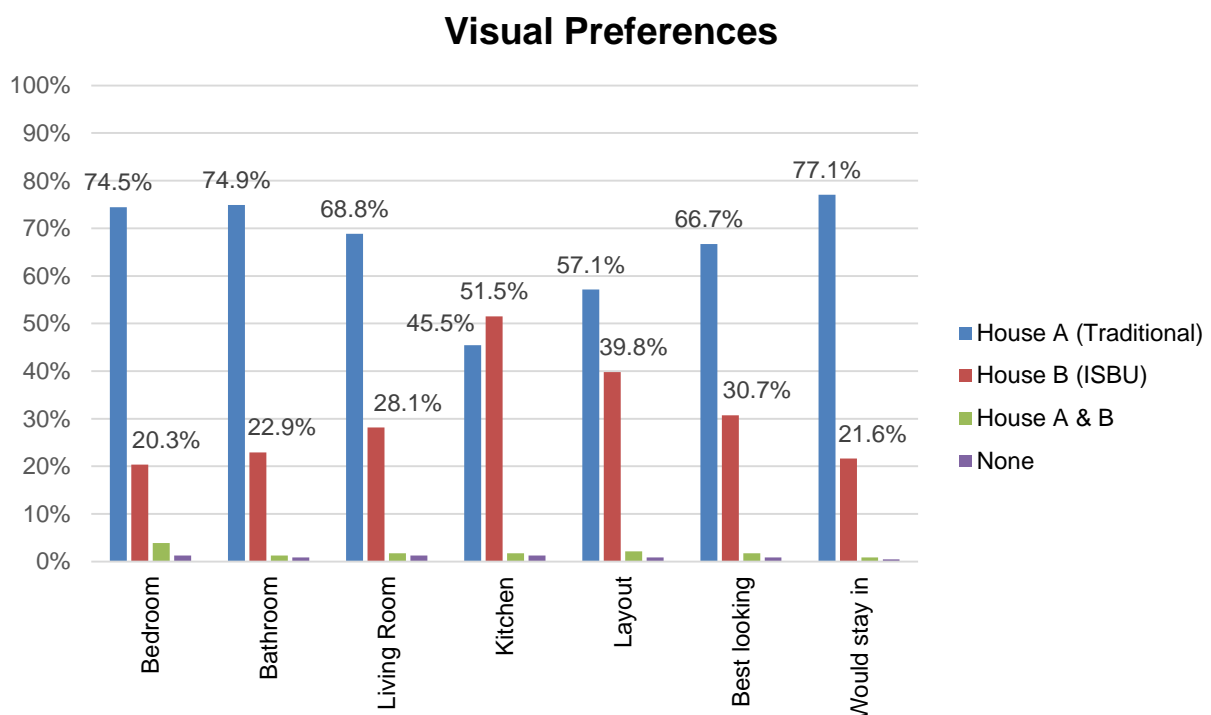


A total of seven different photosheets (relating to each of the seven questions) were shown to the respondent. The photosheets are presented in Annexure H1-H4.

The questions were asked in the following order:

- Question 1: “Which bedroom would you want in a home?”
- Question 2: “Which bathroom would you want in a home?”
- Question 3: “Which living room would you want in a home?”
- Question 4: “Which kitchen would you want in a home?”
- Question 5: “Which layout would you like in a home?”
- Question 6: “Which home is good-looking?”
- Question 7: “Which home would you stay in?”

Figure 6.3 shows the results obtained from the respondents. The answers given by the respondents show a strong preference for the conventional method as opposed to the ISBU house. After Question 7 the respondent knows exactly what type of house he/she is comparing the conventional house to (i.e. a “tin house”, according to multiple accounts) and the opinion against the ABT shifts dramatically.



**Figure 6.3** - The preferences of the respondents, according to the visual impact of each home.

### 6.6.2.2 Attribute Preference (Uninformed)

The uninformed attribute preference section of the questionnaire tries to narrow down why someone would prefer one house over another. In this case, the physical characteristics of an ISBU house is compared directly to those of a conventional house.

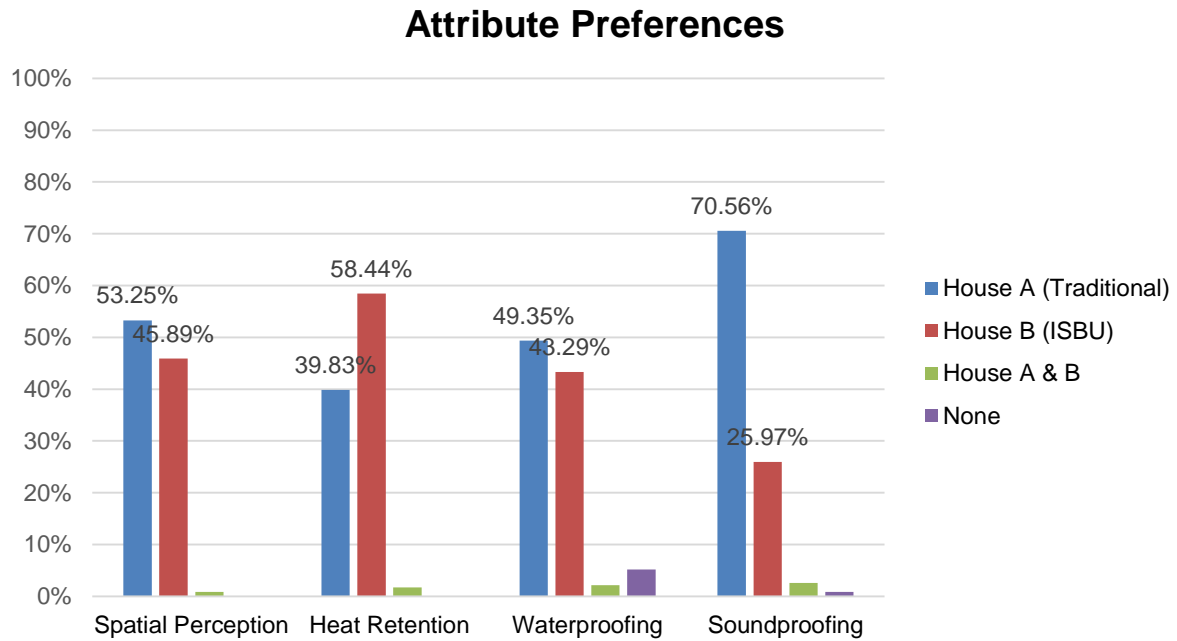
Unfortunately, due to the technical nature of some of the aspects the questionnaire addresses, as well as the cultural and language barriers encountered during the survey, it was difficult to explain what each aspect meant. In an effort to make the questions more understandable, it was decided to describe each characteristic to a relatable event, e.g. instead of asking which structure is better insulated, we asked which structure will be warmer in winter, and similar analogies for the other attributes.

By rephrasing the questions one needed to be extremely careful to still obtain consistent, reliable answers. Thus, an information sheet with examples was handed to all interviewers to use when explaining each concept.

The following questions were asked relating to the spatial perception, insulating capacity, water-resistance and acoustic performance of the different houses.:

- Question 1: “Which home looks spacious inside?”
- Question 2: “Which home looks warm in the winter? Which home will be cool when it is hot outside?”
- Question 3: “Which home will leak when it rains?”
- Question 4: “Which is home is quiet inside if people are noisy outside?”

Figure 6.5 shows a small difference for the preferred spatial perception between the two cases. However, (surprisingly) most respondents believed that the ISBU solution was the best insulated. The waterproofing aspect was again matched closely, but the soundproofing aspect gave a large lead over the ISBU building, which is a reasonable deduction.

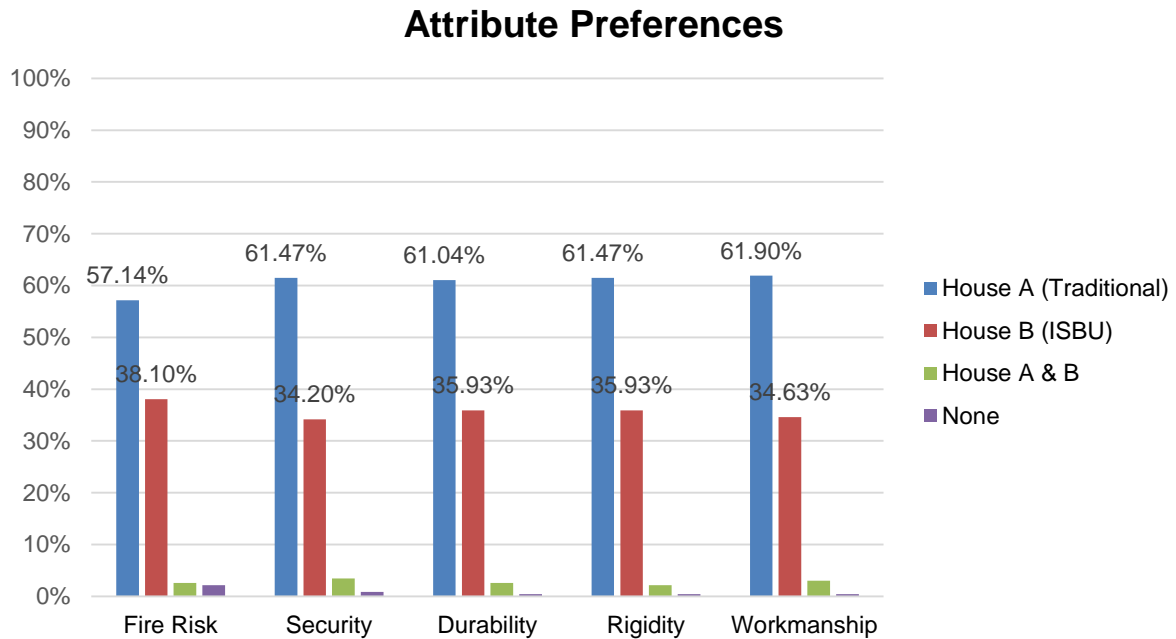


**Figure 6.4** - The preferences of the respondents, according to the spatial, heat retention, waterproofing and soundproofing attributes of each home.

The following questions were asked regarding fire risk, home security, home durability, structure integrity and product workmanship:

- Question 5: “Which home can burn down easily? Which home will catch fire first?”
- Question 6: “Which home looks safe? Which home will thieves break into?”
- Question 7: “Which home will last long? Which home will you be able to give to your children one day?”
- Question 8: “Which home looks strong? Which home won’t be blown down by the wind?”
- Question 9: “Which home looks well built? Which home won’t have cracked walls, or broken roofs?”

Figure 6.5 shows an overall majority of respondents prefer the conventional method. The preference of the conventional method regarding workmanship also matches the public consultation report that was done by the DHS in 2010 (Department of Human Settlements, 2010).

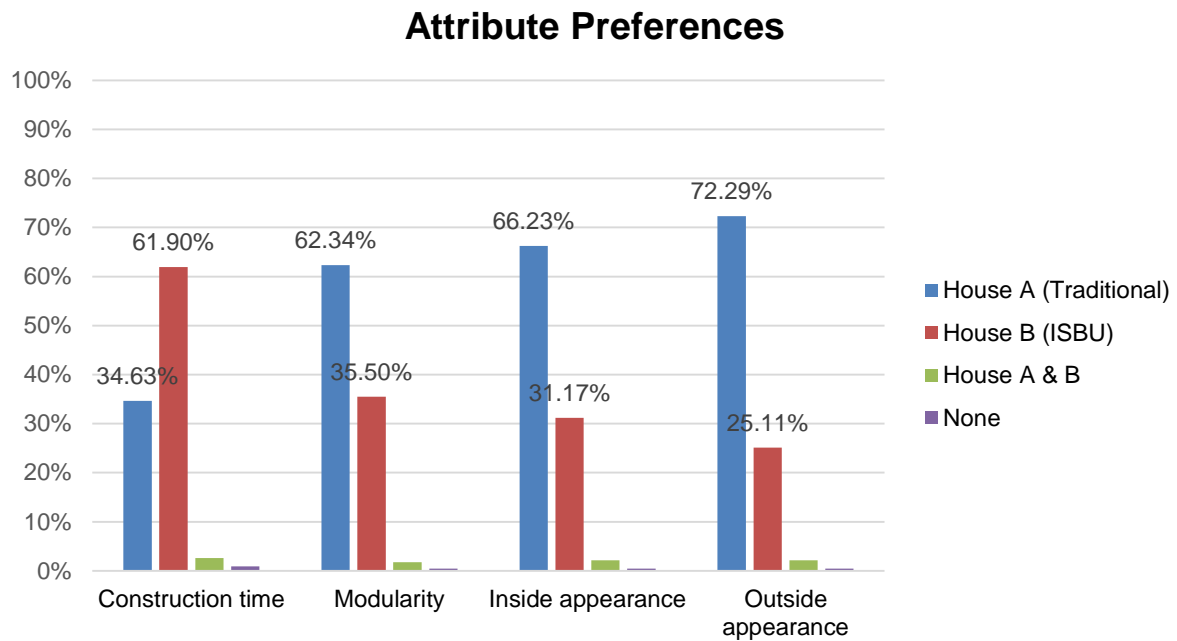


**Figure 6.5** - The preferences of the respondents, according to the fire risk, security, durability, rigidity and workmanship.

Finally, the following questions regarding home construction time, modularity benefit, inside appearance and outside appearance were asked:

- Question 10: “Which home can be built quickly? Which home will take the shortest time to build?”
- Question 11: “Which home is easy to make bigger?”
- Question 12: “Which home is good-looking on the inside? Which home looks nice inside?”
- Question 13: “Which home is good-looking on the outside? Which home looks nice outside?”

Figure 6.6 shows that the majority of respondents agreed that the ISBU solution takes less time to construct. The preference of the modularity and the overall appearance aspect, however trailed behind the conventional method to a large extent.



**Figure 6.6** - The preferences of the respondents, according to the fastest construction time, modularity benefit, inside and outside appearance.

### 6.6.3 Preference for ISBU or Conventional Housing, with Perfect Information

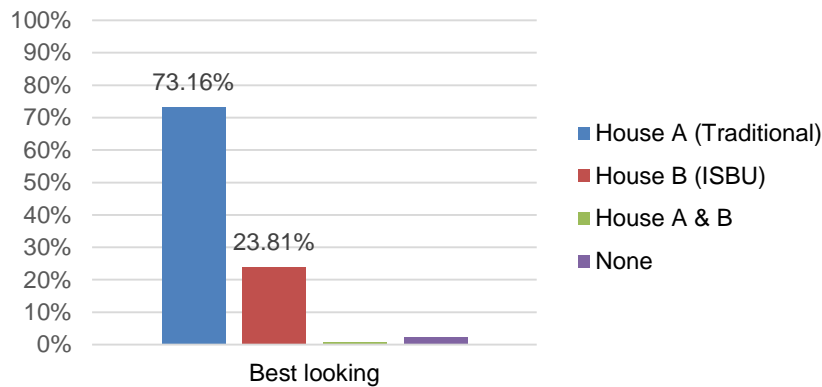
After the respondents delivered their opinions regarding the visual appearance and physical attributes of the ISBU solution, they were given a comparison information sheet. This sheet contains all the requirements and standards that are met by the ISBU solution as designed in Chapter 4, and can be considered accurate in the sense of the survey. The sheet also contains the conventional solution with drawbacks and advantages to each system. After reading the information sheet, the respondents were again asked to compare the two solutions.

#### 6.6.3.1 Visual Preference (given Perfect Information)

With regards to the visual appearance section, the respondent had a second chance to decide whether he preferred the ISBU or conventional solution. The question was asked as: "Which house is the best looking?"

According to the results, 40 people changed their mind from their previous result, with 21 people deciding that the ISBU looked better, while 19 decided that the conventional solution looked better. This evens out, with the majority of people preferring the conventional solution as seen in Figure 6.7.

### Visual Preference with Perfect Information



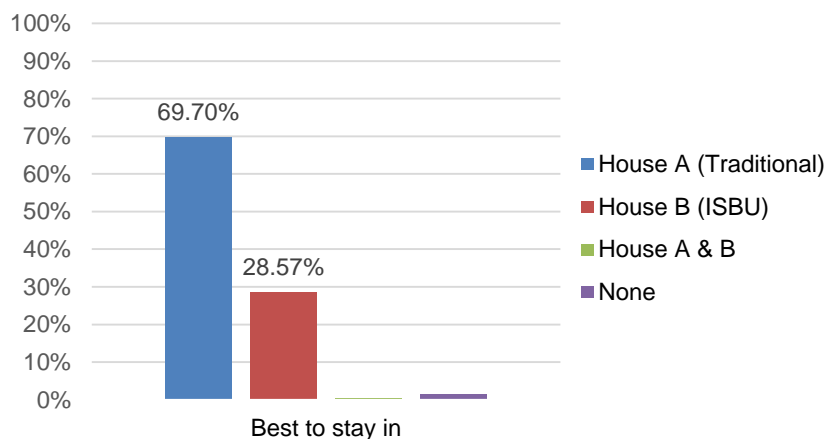
**Figure 6.7** - The preferences of the respondents, according to the visual impact of each home. This was the result after being presented with perfect information.

#### 6.6.3.2 Attribute Preference (given Perfect Information)

The next section asked the respondent whether the physical attributes of the one solution was better than the other. The question that was asked is: "Which house is better to stay in?"

An overwhelming majority preferred the conventional solution, with only 28.6% preferring the ISBU home as can be seen in Figure 6.8.

### Attribute Preference with Perfect Information

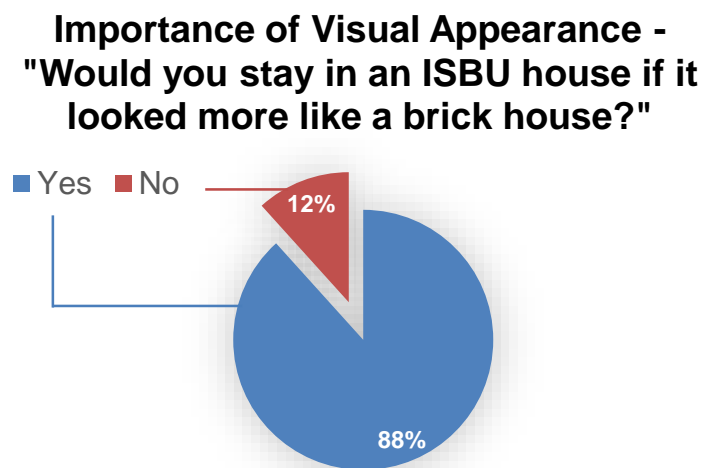


**Figure 6.8** - The preferences of the respondents, according to the physical attributes of each home. This was the result after each respondent was presented with perfect information.

### 6.6.3.3 Importance of Visuals

The last question focused solely on the appearance of the homes. The question that was asked is: "Would you stay in House B if it looked like a normal house?"

Most respondents agree with the statement, with 88% saying they will stay in a container home if it looked like a normal one, as one can see in Figure 6.9.



**Figure 6.9** - The willingness of the respondent to stay in an ISBU house if it resembled a conventional house.

## 6.7 Conclusion

This chapter aimed to investigate the housing opinion of beneficiaries living in an informal settlement, and their willingness to accept an alternative building technology in the form of shipping containers. In general, it was expected that communities will show a negative perception towards ABT housing, as mentioned by ABT fabricators (Gronloh, 2013). According to the literature, this is due to a perceived sense of "low-quality" housing when brick and mortar are not utilised. In order to gauge this acceptance towards ABTs, a large-scale face-to-face survey was performed in an informal settlement with the help of trained assistants.

The survey aimed to determine whether a disapproval of container-based housing is founded on truth or stigma, and whether the public can be convinced to live in an ISBU based-home if some changes were made.

The results show that most respondents outright preferred the conventional house, from its visual appearance to the physical characteristics. However, when presented with "perfect



information”, i.e. a factsheet regarding the true physical characteristics showing a definite advantage to ISBUs, most respondents did not change their opinion. From this, one can deduce that respondents are less interested in the performance of a house than the constraints of their cultural norms. This implies that most people would prefer a type of house that they grew up in, or that they believe is best regardless of fact.

However, it was found that a general disapproval of the ISBU solution was based primarily on the outside appearance of the home. This proves valuable for ABT companies as a change in design, pre-project marketing execution or marketing to the commercial housing sector can increase the acceptability of ABT housing in the low-cost sector.

## CHAPTER 7

# ENVIRONMENTAL IMPACT OF ISBU HOUSING

### 7.1 Introduction

This chapter investigates the life cycle environmental impact difference between a conventional low-cost house design, and an ISBU-based low-cost house design. This is achieved by building on the work done by Brewis, regarding the environmental impacts of low-cost housing in South Africa. A quantified partial Life Cycle Assessment of the construction phase of two low-cost housing designs will be performed: the single-storey ISBU test case developed in Chapter 4, and the single-storey conventional case. The results will then be compared to determine the feasibility of an ISBU-based solution.

### 7.2 Background to the Quantitative Environmental Impact Modelling

The environmental impact of a construction method is a difficult process to measure, but aims to provide a combined indication of how many resources are consumed, and how much waste is generated. Brewis chose a partial LCA method that focused on four different indicators, namely (Brewis, 2012):

- Carbon Footprint, as a measure of kg CO<sub>2</sub> produced;
- Acidification Potential, as a measure of kg SO<sub>2</sub> produced;
- Resource Depletion, as a measure of the maximum work potential in J<sub>ex</sub>; and
- Waste Diversion, as a measure of waste produced to landfill in kg.

In addition, these indicators were only considered in the pre-use (i.e. construction) phase of low-cost housing for the research study, as sufficient data on the long-term impact for container housing was lacking.

The means for calculating the combined environmental impact is described as a three-stage method, namely “*environmental impact assessment, normalisation with respect to a common reference and finally weighting of the impacts in terms of relative importance*”, (Brewis, 2012).

To get the combined environmental effect through this three-stage method, the use of simple multiplication of the quantities (as measured in the bills of quantities) with certain impact factors was followed. These factors were obtained from the EcoInvent Database (EID) as developed by the Swiss Centre for Life Cycle Inventories. The next sections detail the

mathematical steps that was followed to obtain the result, as well as the chosen weighting factors. Carbon Footprint

The carbon footprint, as measured in kg CO<sub>2</sub>, is obtained by multiplying the mass of material used by a CO<sub>2</sub>-production factor (in units of kg CO<sub>2</sub> produced per kg construction material) obtained from a database documenting the lifecycle impacts of certain materials. The equation is as follows:

$$\text{Carbon Footprint [kgCO}_2\text{]} = \text{Mass[kg]} \times \text{EID factor[kgCO}_2\text{ per kg]} \quad (7.1)$$

### 7.2.1 Acidification Potential

The acidification potential, as measured in kg SO<sub>2</sub>, is similarly calculated as the carbon footprint with the appropriate factor. The equation is as follows:

$$\text{Acidification Potential [kgSO}_2\text{]} = \text{Mass[kg]} \times \text{EID factor[kgSO}_2\text{ per kg]} \quad (7.2)$$

### 7.2.2 Resource Depletion

The resource depletion is measured in MJ-equivalents, and is calculated in the same way as the previous two indicators, albeit with the correct factor as obtained from the EcoInvent database. The equation is as follows:

$$\text{Resource Depletion[MJ. eq]} = \text{Mass[kg]} \times \text{EID factor[MJ. eq per kg]} \quad (7.3)$$

### 7.2.3 Waste Generation

The waste generation is the sum of the production waste of the material and the construction waste. The production waste is calculated as follows:

$$\text{Production Waste [kg]} = \text{Mass[kg]} \times \text{EID factor[kg per kg]} \quad (7.4)$$

The construction waste is more complex to calculate, and based on a volumetric method by Solis-Guzman et al. The calculation utilises two dimensionless factors CR<sub>i</sub> and CE<sub>i</sub> that

determine the proportion of construction wastage (Solís-Guzmán, et al., 2009). The determination of the construction wastage is given stepwise by Brewis as follows:

1. Calculate material quantity per  $m^2$  of the building floor area;
2. Calculate the apparent constructed volume  $VAC_i$  for each item on the bill with its quantity  $Q_i$  and respective unit a conversion factor  $CC_i$  See Equation (7.5);

$$VAC_i[m^3 \text{ per } m^2] = Q_i[\text{unit per } m^2] \times CC_i[m^3 \text{ per unit}] \quad (7.5)$$

3. Calculate the apparent wreckage waste volume  $VAR_i$  by multiplying with dimensionless factor  $CR_i$ ;

$$VAR_i[m^3 \text{ per } m^2] = VAC_i[m^3 \text{ per } m^2] \times CR_i \quad (7.6)$$

4. Calculate the apparent packaging waste volume  $VAE_i$  by multiplying with a dimensionless factor  $CE_i$ ;

$$VAE_i[m^3 \text{ per } m^2] = VAC_i[m^3 \text{ per } m^2] \times CE_i \quad (7.7)$$

5. Add  $VAR_i$  and  $VAE_i$  and multiply with the building area to obtain the volume of waste for item  $i$ . Sum over all the items to determine the total waste volume [ $m^3$ ];
6. Multiply the waste volume with its density to determine its construction waste.

Thus, the equation for total waste generation is as follows:

$$\text{Waste Generation}[kg] = \text{Production Waste}[kg] + \text{Construction Waste}[kg] \quad (7.8)$$

#### 7.2.4 Normalisation and Weighting Factors

The second and third step, according to Brewis, is the normalisation and weighting of the cumulative impacts to scale each to their “relative importance” regarding their environmental

impact. The factors were chosen according to an Environmental Design of Industrial Products (EDIP) method as advocated by Stranddorf et al. and Goedkoop et al. See Table 7.1 for the individual factors, as adapted from Brewis's work:

**Table 7.1** - EDIP Normalisation and weighting factors.

Impact	Normalisation	Weighting
	Value	Factor
Carbon Footprint	8700	1.12
Acidification Potential	59	1.27
Bulk Waste	1350	1.1

(Adapted from C. Brewis, 2012)

The following sections detail the calculation of the impact of Brewis's conventional home, as well as the impact of the ISBU single-storey solution. Assumptions for each case are detailed in the following sections.

## 7.3 Environmental Impact of Conventional Homes

### 7.3.1 Assumptions

The following assumptions were made by Brewis regarding the implementation of the quantification model:

- Project time set as one year;
- Mortar to sand plastering ratio taken as 4:1;
- 3.5-7.5 ton truck used for transport;
- All generated waste goes to landfill.

Additional assumptions are as follows:

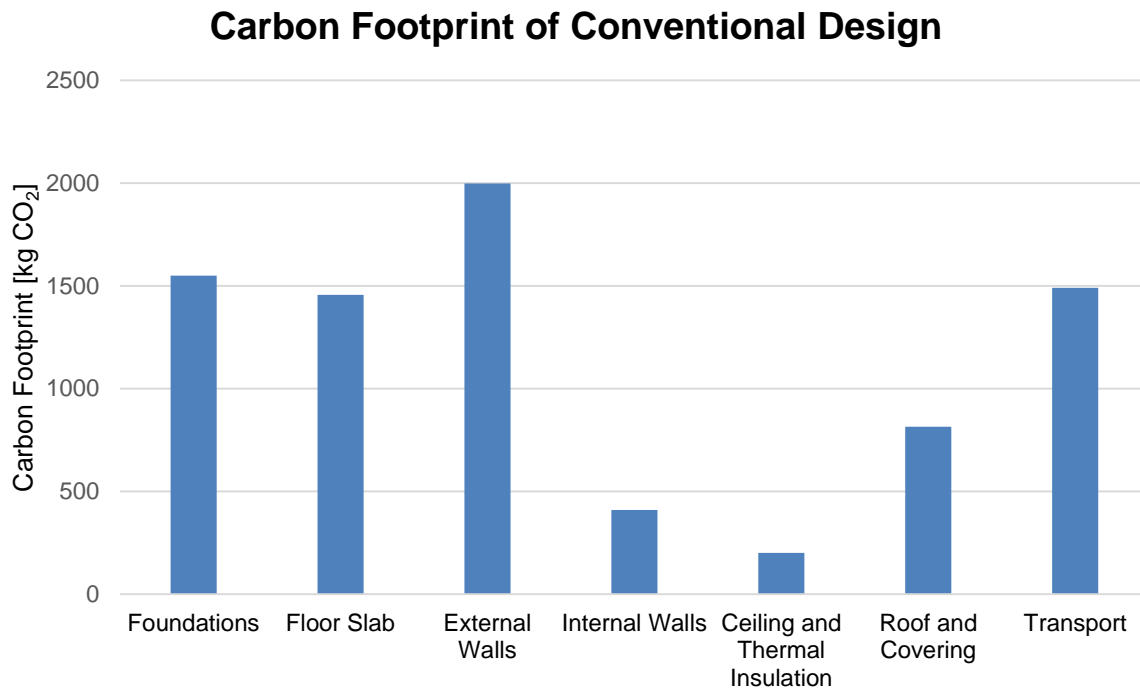
- Transport of all materials assumed to be 50km;
- Windows and doors are not calculated as supporting data is lacking;
- Environmental impact is calculated per household.

### 7.3.2 Results for Conventional Single-storey Control Case

From the bill of quantities for the conventional house design, the four environmental impact indicators were calculated, namely the Carbon Footprint, the Acidification Potential, the Resource Depletion and the total Waste Generation due to the conventional design. This

section shows the results obtained from the calculations in terms of impact for each element of the house.

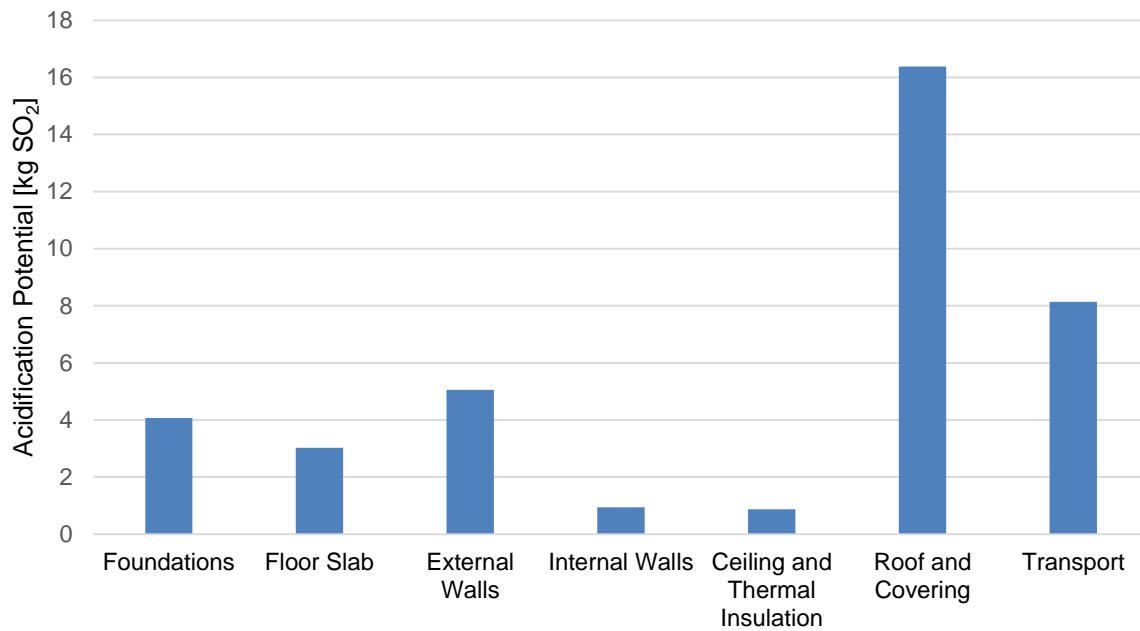
Figure 7.1 shows the Carbon Footprint as measured in kg CO<sub>2</sub> for the conventional 40m<sup>2</sup> BNG house. It is interesting to note the low level of CO<sub>2</sub> generation when considering the internal walls and the ceiling insulation. However, the transport element is the worst offender of CO<sub>2</sub> generation, with the external walls being the second highest.



**Figure 7.1** - Carbon footprint of conventional house design (Brewis, 2013).

Figure 7.2 shows the acidification potential of the conventional 40m<sup>2</sup> BNG house. The highest potential here is due to the transportation (emissions produced) and the roof covering (galvanised sheeting).

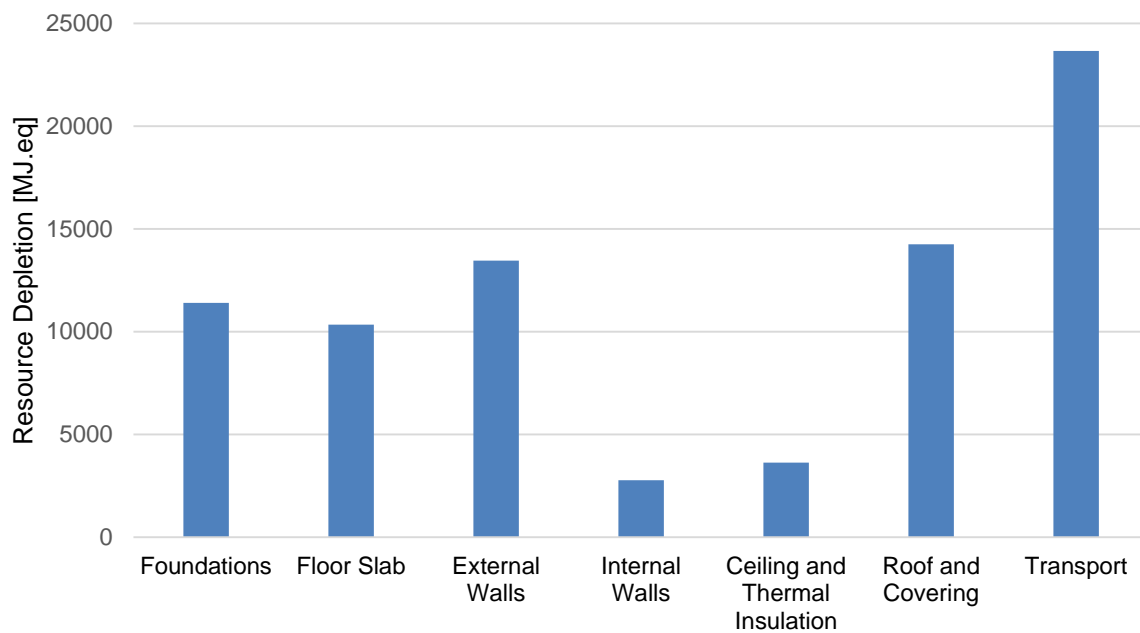
### Acidification Potential of Conventional Design



**Figure 7.2** - Acidification potential of conventional house design (Brewis, 2013).

Figure 7.3 show the resource depletion in terms of MJ.eq's. The transport element of construction is very high here, and is due to the large transport distance of 50km.

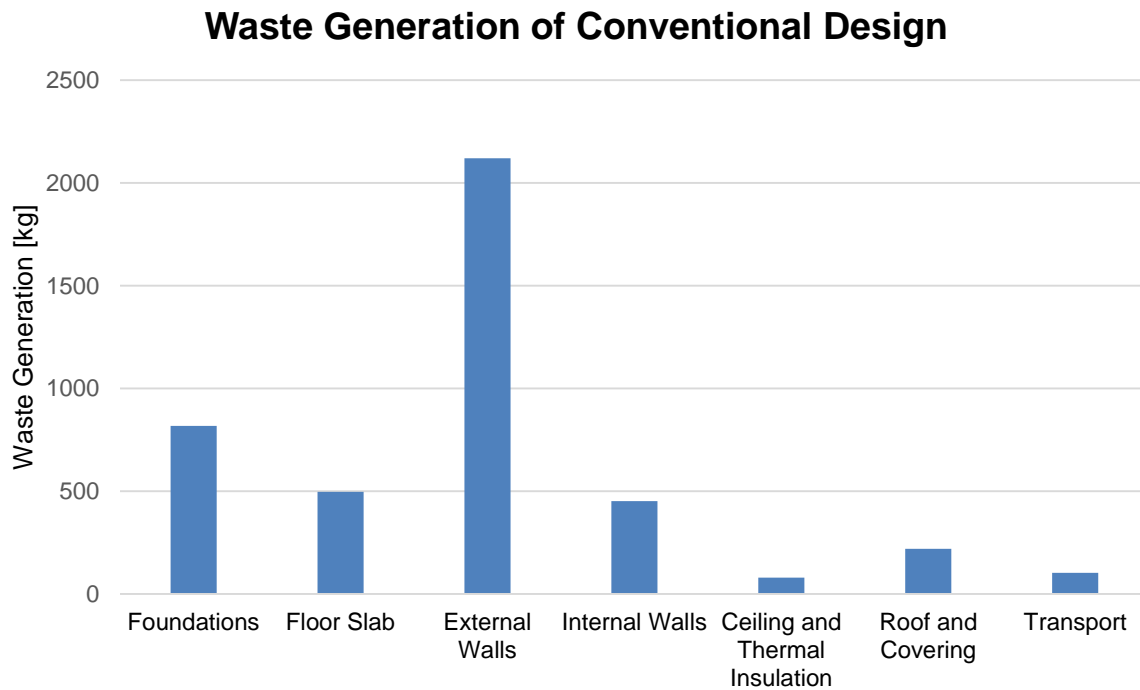
### Resource Depletion of Conventional Design



**Figure 7.3** - Resource depletion of conventional house design (Brewis, 2013).



Figure 7.4 shows the waste generated by the building, with the external walls creating more than 2 tons of waste.



**Figure 7.4** - Waste generation of conventional house design (Brewis, 2013).

Table 7.2 provides a summary of the total environmental impacts

**Table 7.2** - Summary of total environmental impact of conventional house design.

Impact	Total Quantity	Unit
Carbon Footprint	7922.77	kg CO <sub>2</sub>
Acidification Pot.	38.48	kg SO <sub>2</sub>
Resource Depletion	79501.37	MJ.eq
Waste Generation	4291.88	kg

## 7.4 Environmental Impact of ISBU Homes

### 7.4.1 Assumptions

- Project time set as one year, same as conventional case;
- 3.5-7.5 ton truck used for transport;
- All generated waste goes to landfill.

Additional assumptions are as follows:

- Transport of all materials calculated as 50km;
- Assume most materials can be shipped together with containers, to reduce transport costs;
- Windows and doors are not calculated as supporting data is lacking;
- Due to the upcycling nature of the containers, the steel are not calculated into the carbon footprint, acidification potential or resource depletion;
- Environmental impact is calculated per household.

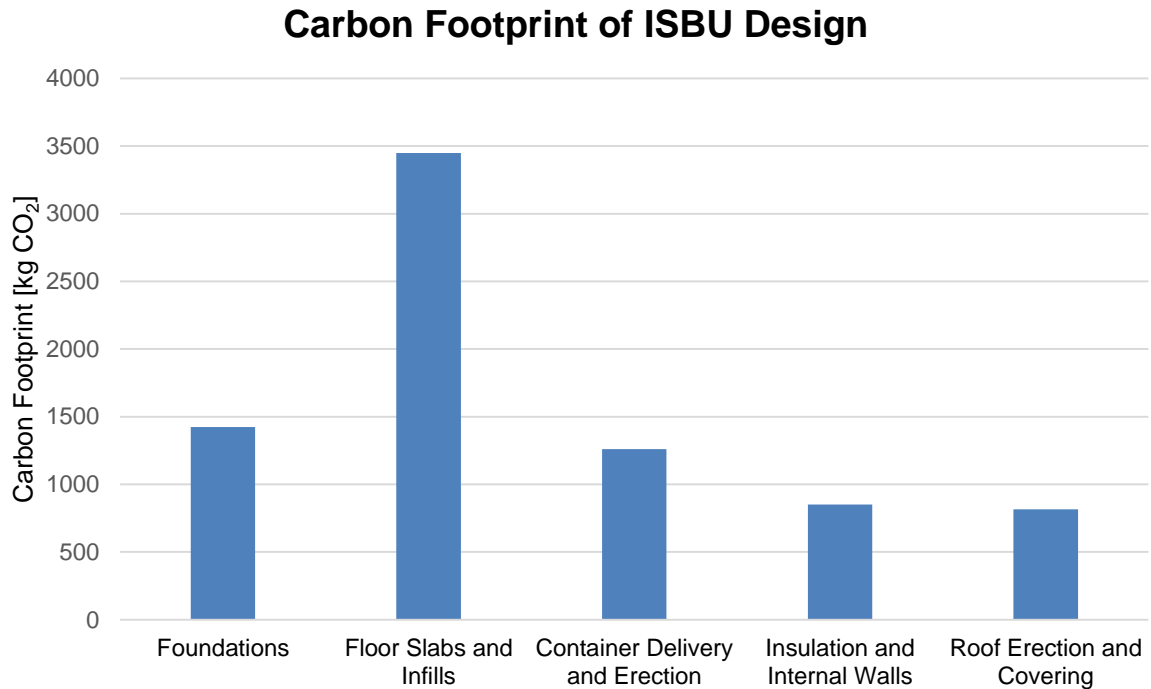
#### **7.4.2 Results for ISBU Single-storey Test Case**

From the bill of quantities for the conventional house design, the four environmental impact indicators were calculated, namely the Carbon Footprint, the Acidification Potential, the Resource Depletion and the total Waste Generation due to the conventional design. This section shows the results obtained from the calculations in terms of impact for each element of the house. A full calculation for the environmental impact calculated for the ISBU single-storey case can be seen in Annex J.

The environmental impact indicators were calculated similarly to the conventional case, with the help of the bill of quantities; however only the single-storey test case ISBU design was considered. In addition, due to two households inhabiting the building, it is necessary to divide all indicators by 2 to get an accurate representation of the environmental impact per household.

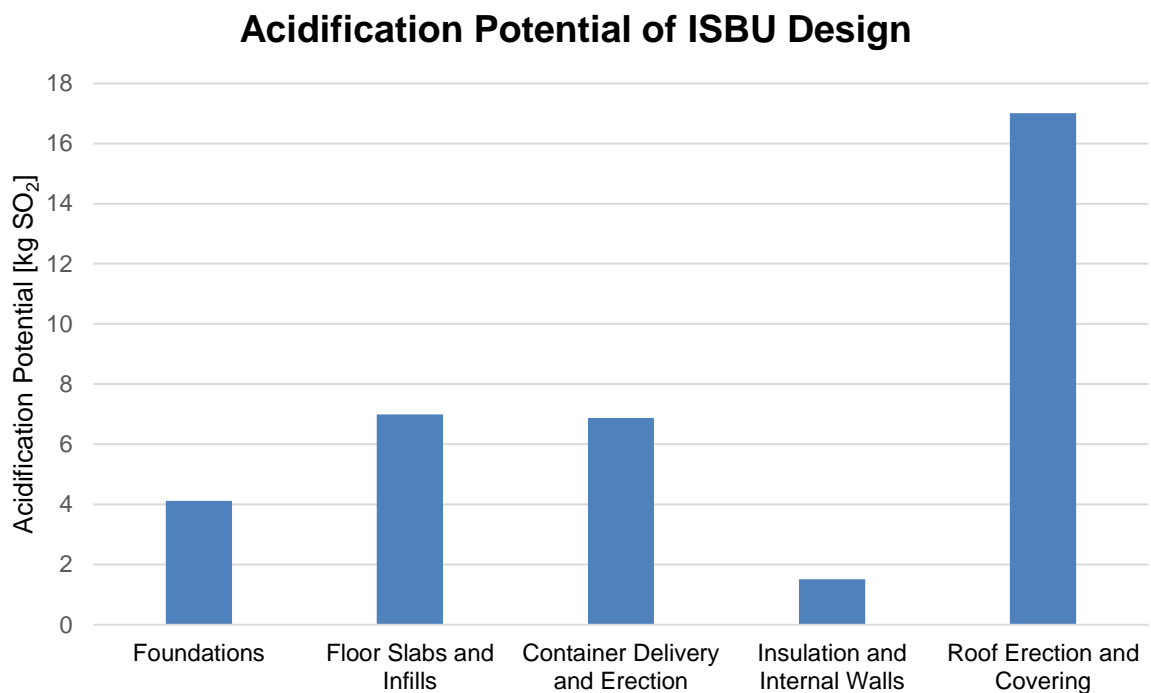
Figure 7.5 shows the Carbon Footprint of the ISBU structure. The high level of CO<sub>2</sub> being generated for the foundations and floor slabs are due to the large amount of concrete used. The impact of the container delivery and erection is also significant, and shows why it is important to source containers as close as possible to the construction site. Note that the delivery and erection includes the container transport, as well as the material transport costs and impacts.

In addition, the optimisation of the concrete foundation can lead to both cost savings and a lower environmental impact.



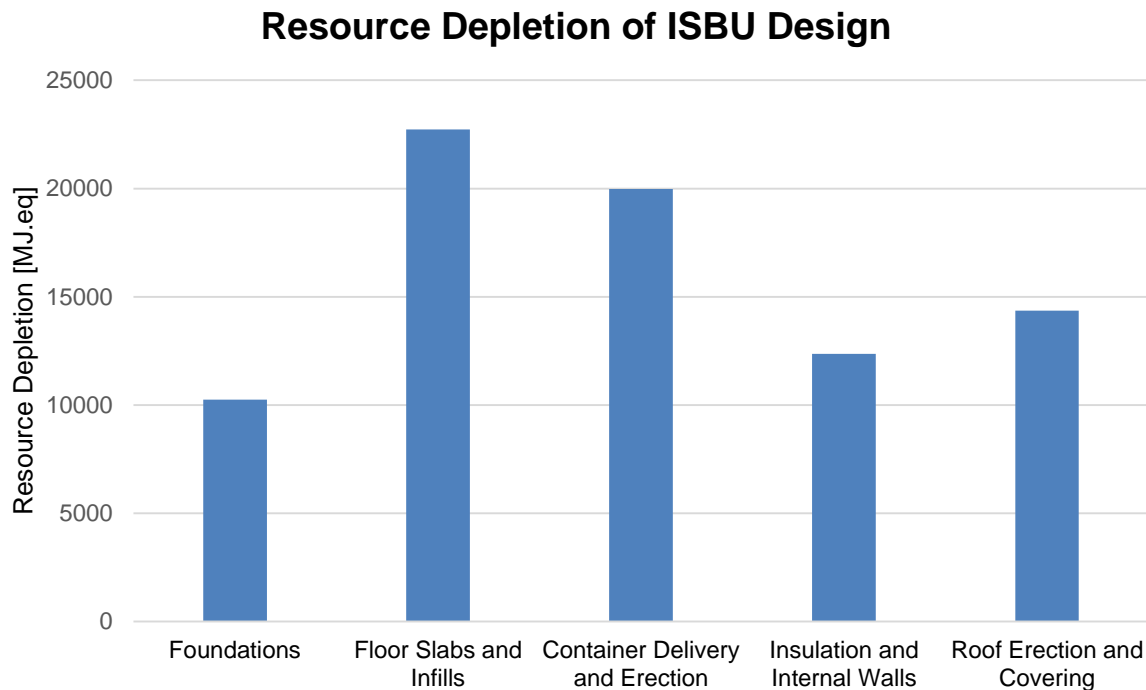
**Figure 7.5** - Carbon footprint of ISBU single-storey house design.

Figure 7.6 shows a very low acidification potential of the insulation, however the acidification potential of the rest of the structure elements are quite high.



**Figure 7.6** - Acidification potential of ISBU single-storey house design.

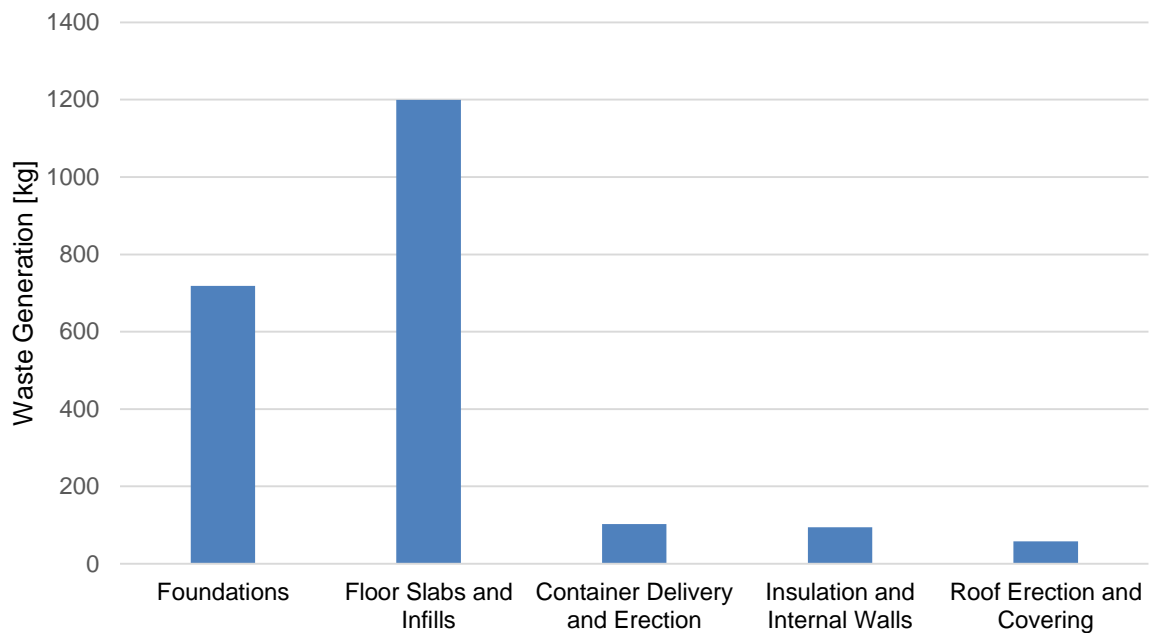
Figure 7.7 shows the resource depletion of the building elements, with the foundations, floor slabs and transport being the worst offenders.



**Figure 7.7** - Resource depletion of ISBU single-storey house design.

Figure 7.8 show the waste generation of an ISBU house, which is much lower when compared to the conventional case. This partly due to the upcycling aspect of re-using an existing structure (i.e. the container shell).

### Waste Generation of ISBU Design



**Figure 7.8** - Waste generation of ISBU single-storey house design.

Finally, Table 7.3 shows the tabulated total environmental impacts regarding the four indicators.

**Table 7.3** - Summary of total environmental impact of ISBU single-storey house design.

Impact	Total	
	Quantity	Unit
Carbon Footprint	7798.016	kg CO <sub>2</sub>
Acidification Pot.	36.49844	kg SO <sub>2</sub>
Resource Depletion	79693.18	MJ.eq
Waste Generation	2172.804	kg

When compared with the conventional design case, one can see that the carbon footprint for the ISBU case is a bit higher, as well as the resource depletion. However, the acidification potential is lower than the conventional case, and 1.5-ton less waste is generated by using ISBUs.

As mentioned in the background of this chapter, one must still normalise and weight the values obtained before a direct environmental impact (EI) comparison can be made. This will be investigated in the next section.

## 7.5 Comparison between Systems

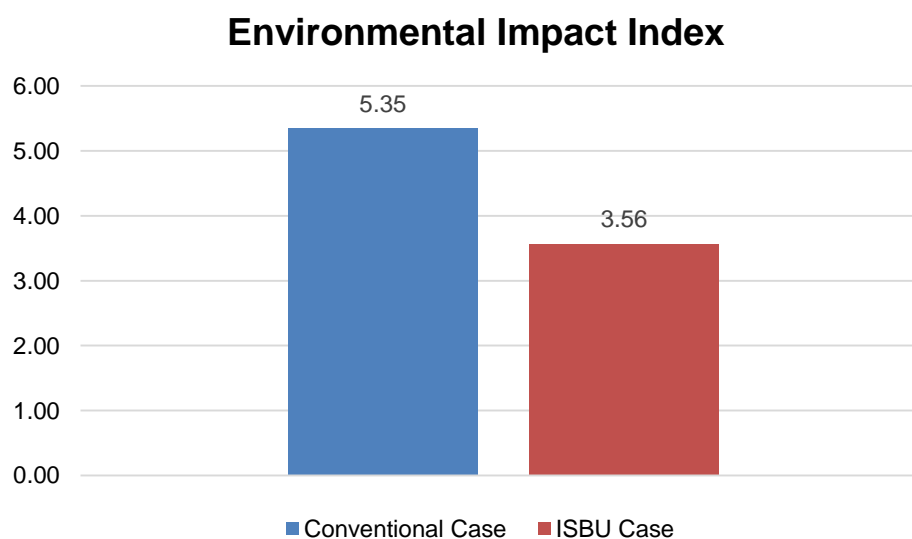
In order to complete the comparison of the two design types, it is necessary to apply the normalisation and weighting factors to the carbon footprint, the acidification potential and the waste generation indicators. The purpose of this is to show the relative importance of each impact to each other (Brewis, 2012). This is calculated and presented in Table 7.4:

**Table 7.4** - Normalised and weighted Environmental Impact values

	Carbon Footprint [kg CO <sub>2</sub> ]		Acidification Potential [kg SO <sub>2</sub> ]		Waste Generation [kg]	
	Convent.	ISBU	Convent.	ISBU	Convent.	ISBU
<b>Impact</b>	7922.77	7798.02	38.48	36.50	4291.88	2172.80
<b>Normalised</b>	0.91	0.90	0.65	0.62	3.18	1.61
<b>Weighted</b>	1.02	1.00	0.83	0.79	3.50	1.77

According to the table, the carbon footprint and the acidification potential carries less weight than the waste generation indicator. The reason for the low level of waste generation for the ISBU case design is due to the fact that the main load-bearing frame, i.e. the shell, is already built. In addition, this shell has been reused with minimum modification and this results in a low level of waste production.

Refer to Figure 7.9 for the cumulative environmental impact index. According to the calculations that was done, the conventional design case has a higher environmental impact than the ISBU case.



**Figure 7.9** - Environmental Impact Index of both cases.

## 7.6 Conclusion

In summary, the environmental impact of a construction method can be quantified according to four different parameters, namely the carbon footprint, the acidification potential, the depletion of resources and the waste generated during the analysed phase. The complete lifecycle analysis of a container is difficult to execute, as additional information, which could not be obtained for the research, is needed for a thorough analysis. Therefore, only the construction phase of a conventional housing design was compared to the construction phase of an alternative housing design.

Brewis developed an environmental analysis model in 2012, which encapsulated the most important environmental impact factors during the construction phase of different building technologies. It was decided that this model is sufficient for the purposes of this study, which only aims to obtain an estimate regarding the environmental impact of ISBU construction. Therefore, the rugged and easily implemented model developed by Brewis would be sufficient for the purposes of an environmental comparison.

This chapter described the calculation method of the important environmental impacts, as well as the calculation of the conventional solution as used by Brewis (which is the typical 40m<sup>2</sup> BNG house). The proposed model was then used to calculate the environmental impact of the single-storey ISBU test case design by utilising the bill of quantities as developed in Chapter 4 in a similar way.

The results show that the construction phase of the ISBU design does not have such a large environmental impact as that of a conventional design. This can be attributed to the assumption that a discarded, refurbished container shell is “upcycled”, i.e. reused with minimal modification for another purpose. Therefore, the pre-construction phase of a container (when it is built, used, maintained and scrapped during its shipping lifecycle) does not contribute to its environmental impact.



## CHAPTER 8

### CONCLUSION AND RECOMMENDATIONS

#### 8.1 Summary

The housing backlog in South Africa continues to be a large problem for the government, the beneficiaries living in informal settlements and the role-players in the built environment due to several financial, political and societal issues. These issues plague the effective delivery of houses to people that are living in sub-standard conditions in informal settlements. However, to solve these challenges with a single solution has not come to the fore since the democratisation of South Africa, and is assumed unlikely.

This research study proposed that a new technical solution should be investigated instead, as it may prove to alleviate some of the challenges facing the housing backlog. The trend in modern container architecture in the international built environment provides a cost-effective solution of providing affordable housing by recycling discarded freight shipping containers. Thus, by investigating successful international and the few local projects that utilised ISBUs, one can compare it with the standard BNG house and if it is feasible to use on a wide scale for affordable housing.

In order to compare the use of ISBUs with conventional brick and mortar building methods and materials, it was necessary to evaluate several parameters empirically. In order to be sustainable, a project must subscribe to economic, societal and environmental aspects, and it was decided to test the feasibility of this new building method according to these principles. The economic parameter encapsulated the cost, construction time, possible container supply and the quality assurance of the end-product. The societal parameter investigated the opinion of several beneficiaries living in an informal settlement via a survey, regarding the acceptance of alternative building technologies as compared to traditional brick and mortar homes. The last parameter investigated the environmental impact in terms of the carbon footprint, the acidification potential, resource depletion and waste generation of ISBU construction, as compared to a typical conventional housing solution.

Two different test case designs were evaluated in terms of these three parameters. These test cases were developed from requirements that was determined by the literature review, and a basic structural analysis. The purpose of the analysis was not to provide a definitive structural design, but rather to check if additional stiffening of the structure would be required.

The results obtained for the economic parameter show that ISBU housing is more expensive than conventional housing in terms of single-storey housing solutions. However, significant cost savings can be achieved for a multi-storey ISBU housing design as the cost per square meter decreases for each additional floor. The construction time between a single-storey ISBU and conventional solution also differs slightly, with the ISBU solution taking a shorter amount of time to complete. When comparing the multi-storey solution, it is possible to reduce the construction time to between a third and two-thirds, as opposed to a conventional solution. This is partly due to the built-in structural component of the containers that allows immediate stacking once the units arrive on site, and thus an extremely fast erection time. The supply of available containers was shown to be quite small based on international container fleet replacement figures, and this will restrict the size of container-based housing projects. The quality of ISBU housing versus conventional housing is difficult to investigate definitively, as the design type does not affect the end-product quality as much as the implemented quality control procedures. Thus, it was decided to not investigate this parameter.

The results obtained for the societal parameter shows that the majority of rural settlement inhabitants prefer a traditional brick and mortar home, as opposed to an ISBU home. Even when the respondents were presented with an information sheet showing that an ISBU solution can provide better physical attributes (such as better insulation, better durability, etc.), it did not sway the opinion of the beneficiaries. This is partly due to the cultural norms and housing preferences of the beneficiaries, where the ideal house is described as a single-storey standalone unit on a small plot of land. However, due to suitable land becoming more and more scarce for development projects, it will be necessary to consider higher-density housing for low-income beneficiaries. Interestingly, it was found that respondents would consider an ISBU house if its visual appearance was identical to a conventional house (namely flat finished walls instead of steel profiled walls, wooden frame doors instead of steel frame doors, a duo-pitch roof etc.). Therefore, the homeowners can possibly be swayed into accepting alternative housing if enough marketing is done beforehand, if there are several other showcase examples of successful ISBU projects and if the ISBU solution shared a similar appearance to a normal house. This may also apply to all homes that utilise ABTs, and should be considered during conception for future ABT housing projects.

The comparison of the environmental parameter is based on a simplified environmental impact model developed to investigate the impacts for different design types during the construction phase of a project. The results show a significant reduction in the combined environmental impact of using ISBU's instead of conventional construction, as the steel shell from ISBU are not specifically built for residential purposes. The combined, normalised and weighted impact, which calculates the combined effect of the carbon footprint, the acidification potential and the

waste generated, shows that a comparative ISBU house will have a relative environmental impact of less than 64% of a comparable conventional house. Therefore, the use of ISBU can prove to be more environmentally responsible than conventional housing solutions.

## 8.2 Discussion of Feasible and Non-feasible Cases

The results obtained from the research study show that an ISBU solution is more expensive in terms of price per square meter than that of a conventional solution. Where the national subsidy allocation for the top structure of a BNG house is approximately R68 000 for a 40m<sup>2</sup> home, a similar ISBU design would cost almost R92 000 for 48m<sup>2</sup>. Therefore, a single-storey ISBU solution is too expensive to implement cost-effectively. However, the multi-storey solution would cost approximately R75 000 for a 48m<sup>2</sup> home, which is close to that of a single-storey solution, and which is much cheaper than comparative conventional multi-storey housing solutions, which can cost between R5 000 and R8 000 per square meter (which equals more than R200 000 for a 40m<sup>2</sup> home). Note that this figure is an estimate, as conventional multi-storey case studies vary to a higher degree than single-storey solutions. This implies that ISBU housing can realistically be used for housing in the gap market range, instead of the subsidised low-cost housing market.

The construction time of a conventional housing solution is significantly larger when compared to multi-storey and single-storey ISBU housing solutions. A general range of time savings is difficult to estimate as it differs from case to case. However, if construction time is a large factor, an ISBU solution will prove to be faster in general than a conventional solution.

ISBU solutions will not be able to be implemented on massive housing projects, as the yearly retirement rate of shipping containers is too low. It can however, be used in certain large projects if enough lead-time is allowed. However, the estimated availability of usable containers show that it is a major handicap for wide scale construction projects. It also shows that container-based construction will be unable to dramatically influence the housing backlog in South Africa.

The acceptability of ISBU solutions by beneficiaries will be problematic, even if the appearance is made to resemble that of a conventional house. If ISBU projects are implemented to a larger degree and its exposure increases, it may become acceptable to people's norms and housing preferences. This can take a long time however, and sufficient marketing should rather be followed if an ISBU solution is to be implemented.

The environmental aspect shows that the impact on the environment is significantly less when using ISBU's than conventional construction. This is due to the fact that “...*the greenest structure is the one that doesn't need to be built*”, (van der Merwe, 2013).

### 8.3 Recommendations for Future Research

Several additional aspects should be investigated further to determine applicable projects for ISBU design types. Future research topics regarding ISBU housing are as follows:

- A comparison of ISBU solutions to other ABT systems available in the South African built environment can provide further details into the feasibility of ISBU designs. Systems such as the Moladi building system, iKhaya Future House systems, Imison building systems etc. could be investigated and a feasibility matrix compiled that shows which method is suited for which conditions;
- The survey regarding social acceptance only considered single-storey housing solutions. A second survey in a more densely populated area should be conducted that measures the acceptability of medium-density housing solutions, with the conventional design contrasted with the ISBU design;
- The environmental impact was only considered for the construction phase of a conventional and ISBU design. However, a complete lifecycle analysis of environmental impacts over the lifetime of each design would provide a better reflection of total environmental impact;
- A sensitivity analysis of cost, construction time and environmental impact dependent on transport distance should be conducted to investigate the maximum effective range of feasible projects around a major port, or shipping container distribution facility. It is expected that the transport costs would prohibit the use of ISBUs inland, while the costs in major coastal metropolises would decrease, as most containers will be decommissioned at high volume ports;
- A further optimised design for an ISBU solution can lead to additional cost savings, as well as a shorter project time. It is recommended that the design of the ISBU test cases be refined to a higher degree and then compared to one another in terms of cost, time and environmental impact.

## LIST OF REFERENCES

Adams, W. M., 2006. *The Future of Sustainability: Re-thinking Environment and Development in the Twenty-first Century*. Zurich, The World Conservation Union .

Affordable Housing Development South Africa, 2012. *2nd Annual Low-Cost Housing South Africa Conference*. Johannesburg, s.n.

Alink, H., 2003. Lack of training and poor building skills lead to Cape housing debacle. *Housing in Southern Africa*, Issue June, p. 18.

Baba, M. M., 1998. *Community Participation in Low-Income Housing Projects: Experiences of Newly-Urbanised Africans in Mfuleni in the Cape Metropole*, Stellenbosch: University of Stellenbosch.

Brewis, C., 2012. *Quantifying the Environmental Dimension of Sustainability for the Built Environment: With a focus on Low-Cost Housing in South Africa*, Stellenbosch: Stellenbosch University Press.

Burgoyne, M.-L., 2008. *Factors Affecting Housing Delivery in South Africa: A Case Study of the Fisantekraal Housing Development Project, Western Cape*, Stellenbosch: University of Stellenbosch.

Business Report, 2012. *InfrastructureNe.ws, "R50bn bill follows poor housing workmanship"*. [Online]

Available at: <http://www.infrastructurene.ws/2012/08/07/r50bn-bill-follows-poor-housing-workmanship/>

[Accessed 13 July 2013].

Cochran, W., 1963. *Sampling Techniques*. 2nd ed. New York: John Wiley and Sons, Inc..

Creswell, J. W., 2003. *Research Design: Qualitative, Quantitative and Mixed Methods Approaches*. 2nd ed. Lincoln: SAGE Publications.

Cudahy, B., 2006. The Container Revolution: Malcolm Maclean's 1956 Innovation Goes Global. *TR News*, Issue 246, pp. 5-9.

Currie, I. & De Waal, J., 2005. *Bill of Rights Handbook*. 5th ed. Cape Town: Juta Law Books.

Darkwa, I., 2006. *Post-Occupancy of State-Subsidised Housing Units in Kayamandi, Stellenbosch*, Stellenbosch: University of Stellenbosch.

Darvill, T., 2008. *Concise Oxford Dictionary of Archeology*. 2nd ed. Oxford: Oxford University Press.

de Klerk, D., 2013. *Precast Modular Construction of Schools*, Stellenbosch: Stellenbosch University Press.

Department of Government Communication and Information Systems, 2012. *Pocket Guide to South Africa 2011/2012*. [Online]

Available at: <http://www.gcis.gov.za/content/resourcecentre/sa-info/pocket-guide-south-africa-20112012>

[Accessed 31 July 2013].

Department of Human Settlements, 1994. *A new Housing Policy and Strategy for South Africa*, Pretoria: Government of the Republic of South Africa.

Department of Human settlements, 2009. *Annual Report*, Pretoria: Government of the Republic of South Africa.

Department of Human Settlements, 2009. *The National Housing Code, The Policy Context*, Pretoria: The Government of the Republic of South Africa.

Department of Human Settlements, 2010. *The Use of Alternative Technologies In Low Cost Housing Construction: Why The Slow Pace Of Delivery?*, Pretoria: Human Settlements Review.

Department of Human Settlements, 2011. *Housing Subsidy Factsheet*. [Online] Available at:

<http://www.kzndhs.gov.za/Portals/0/docs/publications/housing%20subsidy%20cfoldsmall.pdf>

[Accessed 22 June 2013].

Department of Human Settlements, November 2011. *Finance-Linked Individual Subsidy Programme*, Pretoria: Department of Human Settlements.

Desjarlais, A. O., 2013. *Which Kind of Insulation is Best?*, Oak Ridge: Oak Ridge National Laboratory.

Education Training Unit NGO, 2007. *Education and Training Unit Community Toolbox*. [Online]

Available at: <http://www.etu.org.za/toolbox/docs/government/housing.html>

[Accessed 31 July 2013].

- FinMark Trust, 2009. *Centre for Affordable Housing Finance, "What is the gap market?"*. [Online]  
Available at: [http://www.housingfinanceafrica.org/wp-content/uploads/2012/04/IHS-conference-input\\_FinMark.pdf](http://www.housingfinanceafrica.org/wp-content/uploads/2012/04/IHS-conference-input_FinMark.pdf)  
[Accessed 19 June 2013].
- Fitchett, A. S., 2009. *Skills Development and Employment Creation Through Small Public Buildings in South Africa*, Stellenbosch: University of Stellenbosch.
- Goedkoop, M., Oele, M., Schryver, A. & Viera, M., 2008. *SimaPro Database Manual*, Netherlands: Pré Consultants.
- GreenBiz News, 2008. *GreenBiz.com*. [Online]  
Available at: <http://www.greenbiz.com/news/2008/09/17/using-recycled-shipping-containers-building-blocks-green-construction>  
[Accessed 16 September 2013].
- Gronloh, M., 2013. *Technical Consultant, Fabricated Steel Manufacturing* [Interview] (4 February 2013).
- H. Slawik, J. B. M. B., 2010. *Container Atlas*. 1st ed. Berlin: Gestalten Verlag.
- Hart, M., 2013. *Lead Architect, Michael Hart Architects* [Interview] (5 February 2013).
- Housing Development Agency, 2008. *The Housing Development Agency, Functions of the Agency According to Act 23, Section 7*. [Online]  
Available at: [http://www.thehda.co.za/uploads/images/LINK\\_Functions\\_of\\_Agency1.pdf](http://www.thehda.co.za/uploads/images/LINK_Functions_of_Agency1.pdf)  
[Accessed 24 June 2013].
- Kennedy, J., 2013. *Mr.* [Interview] (28 June 2013).
- Keuler, J., 2013. *The Sustainability and Challenge of Medium-density Housing in South Africa (Aurecon South Africa)* [Interview] (10 June 2013).
- Khaki, I., 2009. *Housing in South Africa: The Challenge to Provide Sustainable, Integrated, Affordable Housing*, Stellenbosch: Stellenbosch University.
- Kruser, D., 2013. *Human Settlements Manager, Theewaterskloof Municipality* [Interview] (24 May 2013).
- Levinson, M., 2006. *The box: How the shipping container made the world smaller and the world economy bigger*. Princeton: Princeton UP.



- Lizarralde, G. & Massyn, M., 2008. Unexpected Outcomes of Community Participation in Low-Cost Housing Projects in South Africa. *Habitat International*, 30 November, 32(1), pp. 1-14.
- McDonald, D., 2002. *Cost Recovery and the Crisis of Service Delivery in South Africa*. 1st ed. Cape Town: Human Sciences Research Council Publishers.
- Merriam-Webster Inc., 1994. *Merriam-Webster's Dictionary of English Usage*. 2nd ed. Springfield, MA: Merriam-Webster, Incorporated, 1994.
- Milankovic, D. et al., 2013. *Life cycle assessment of an intermodal steel building unit*, Novi Sad, Serbia: University of Novi Sad.
- Montgomery, D. C. & Runger, G. C., 2007. *Applied Statistics and Probability for Engineers*. 4th ed. Phoenix, USA: John Wiley & Sons, Inc..
- Morris, E. & Winter, M., 1978. *Housing, Family and Society*. New York: John Wiley.
- Morris, E., Winter, M. & Murphy, A., 1986. *Housing Adjustment, Satisfaction, and Quality/Quantity Considerations in Housing: The Case of Oaxaca De Juarez*, s.l.: Iowa State University.
- Muyeba, S., 2011. *Privacy and the weakness of community: Poor Post-Apartheid urban neighbourhoods in Cape Town, South Africa*, Cape Town: Centre for Social Science Research.
- Myburgh, M., 2013. *Consulting Engineer, BVi Consulting* [Interview] (4 February 2013).
- Naber, G., Duken, U., Mast, E. W. & Schieder, U.-P., 2013. *The GDV Container Handbook - Cargo Loss Prevention Information from German Marine Insurers*, Munich: Deutschen Versicherungswirtschaft.
- National Department of Housing, 2003. *Design and Construction of Houses*, Pretoria: s.n.
- National Housing Finance Corporation, 2011. *Finance-Linked Individual Subsidy Programme Brochure*. [Online]  
Available at: [http://www.nhfc.co.za/files/FLISP\\_Brochure.pdf](http://www.nhfc.co.za/files/FLISP_Brochure.pdf)  
[Accessed 11 May 2013].
- Newton, C., 2008. *Social housing, urban policy and social capital: Spatial interrelations in a third world context.*, Cape Town: University of Cape Town.
- NHBRC, 2013. *NHBRC talks Alternative Building Technologies*. [Online]  
Available at:

<http://www.nhbrc.org.za/files/news/NHBRC%20talks%20Alternative%20Building%20Technologies.pdf>

[Accessed 2 August 2013].

Nicholas, J. M. & Steyn, H., 2008. *Project Management for Business, Engineering and Technology - Principles and Practice*. 3rd ed. Oxford: Butterworth-Heinemann.

Oom, B., 2013. *Western Cape Government - News and Speeches*. [Online] Available at: <http://www.westerncape.gov.za/news/media-alert-beneficiaries-receive-houses-kayamandi>

[Accessed 29 August 2013].

Open Architecture Network, 2010. [Online] Available at: <http://openarchitecturenetwork.org/projects/6408>

[Accessed 5 September 2013].

Papier, K., 2013. *Councilor, Theewaterskloof Municipality* [Interview] (3 June 2013).

Pauli, G., 2010. *The Blue Economy*. 1st ed. s.l.:Paradigm Publications.

Pieterse, E., 2004. Untangling 'integration' in urban development policy debates. *Urban Forum*, Issue 15, pp. 1-35.

R.J. Essery, D. R. W. S., 1970. *British Goods Wagons from 1887 to the Present Day*. 63 ed. London: David & Charles Publishers.

Ripley, D., 1993. *The Little Eaton Gangway and Derby Canal*. 2nd ed. Oxford: Oakwood Press.

Rust, K., 2006. *Analysis of South Africa's Housing Sector Performance*, Pretoria: Finmark Trust.

SABS Standards Division, 2008. *SOUTH AFRICAN NATIONAL STANDARD 10400-2008*, Pretoria: SABS Standards Division.

SAICE, 2012. Community Residential Unit Refurbishment Programme. *Civil Engineering*, 20(11), pp. 51-55.

Sapa-AFP, 2006. *Mail & Guardian*. [Online] Available at: <http://www.mg.co.za/article/2006-10-18-housing-backlog-increases-despite-new-homes>

[Accessed 24 July 2013].

- Sexwale, T., September 2010. *Alternative Building Technologies Indaba*. Johannesburg, s.n.
- Shi, L., 2005. *Housing Preference of Residents in Stellenbosch, South Africa*, Stellenbosch: University of Stellenbosch.
- Simons, J., Irwin, D. & Drinnien, B., 1987. *Psychology - The Search for Understanding*. 1st ed. New York: West Publishing Company.
- Sisulu, L., 2007. *South African Government Information*. [Online] Available at: <http://www.info.gov.za/speeches/2007/07060816451002.htm> [Accessed 2013 May 5].
- Slawik, H., Bergmann, J., Buchmeier, M. & Tinney, S., 2010. *Container Atlas - A Practical Guide to Container Architecture*. 2nd ed. Berlin: Gestalten.
- Smith, T. N. K., 2010. *The Rise of the Phoenix or an Achilles Heel? Breaking New Ground's Impact on Urban Sustainability and Integration*, Stellenbosch: Stellenbosch University Press.
- Solís-Guzmán, J., Marrero, M., Montes-Delgado, M. & Ramírez-de-Arellano, A., 2009. *A Spanish model for quantification and management of construction waste.*, Seville, Spain: University of Seville.
- South African Department of Performance Monitoring and Evaluation, 2012. *Midterm Review of the Priorities of Government*, Pretoria: The Presidency of the Republic of South Africa.
- Spazatiner, 2013. *Sales Team* [Interview] (24 June 2013).
- Statistics South Africa, 2012. Census 2011. *Statistical Release (Revised)*, 30 October, p. 14.
- Stranddorf, H., Hoffmann, L. & Schmidt, A., 2005. *Impact categories, normalisation and weighting in LCA*. *Environmental News No. 78.*, s.l.: Danish Ministry of Environment.
- Thring, P. & Kahn, F., 2003. *Housing Policy and Practice in Post-Apartheid South Africa*. 1st ed. Pretoria: Heinemann.
- Tonkin, A., 2008. *Sustainable Medium Density Housing Resource Book*, Cape Town: Development Action Group.
- Transnet, 2013. *Transnet Port Terminals*. [Online] Available at: <http://www.transnet.net/Divisions/PortTerminals.aspx> [Accessed 4 September 2013].

Tredoux, M., 2009. *Informal Housing in Cape Town: Delivery, Formalization and Stakeholder Viewpoints*, Stellenbosch: Stellenbosch University.

United States Environmental Protection Agency, 2012. *What is sustainability?*. [Online] Available at: <http://www.epa.gov/sustainability/basicinfo.htm#sustainability> [Accessed 15 June 2013].

van den Heever, G., 2013. *Tankcon Logistics* [Interview] (24 August 2013).

van der Merwe, H., 2013. *CEO of Botes & Kennedy Manyano* [Interview] (26 August 2013).

Wentzel, L., 2010. *An Analysis of Quality Assurance in Low-Cost Housing Construction*, Stellenbosch: Stellenbosch University Press.

Western Cape Government Provincial Treasury, 2013. *Budget: Overview of Provincial Revenue and Expenditure*, Cape Town: Provincial Treasury.

Williams, J., 2000. South Africa: Urban Transformation. *Cities*, pp. 167-183.

World Shipping Council, 2009. *World Shipping Council - About the Industry*. [Online] Available at: <http://www.worldshipping.org/about-the-industry/history-of-containerization/before-container-shipping> [Accessed 13 05 2013].

Wyk, J. V., 1999. *Planning law: Principles and procedures of land-use management*. 1st ed. Kenwyn: Juta.

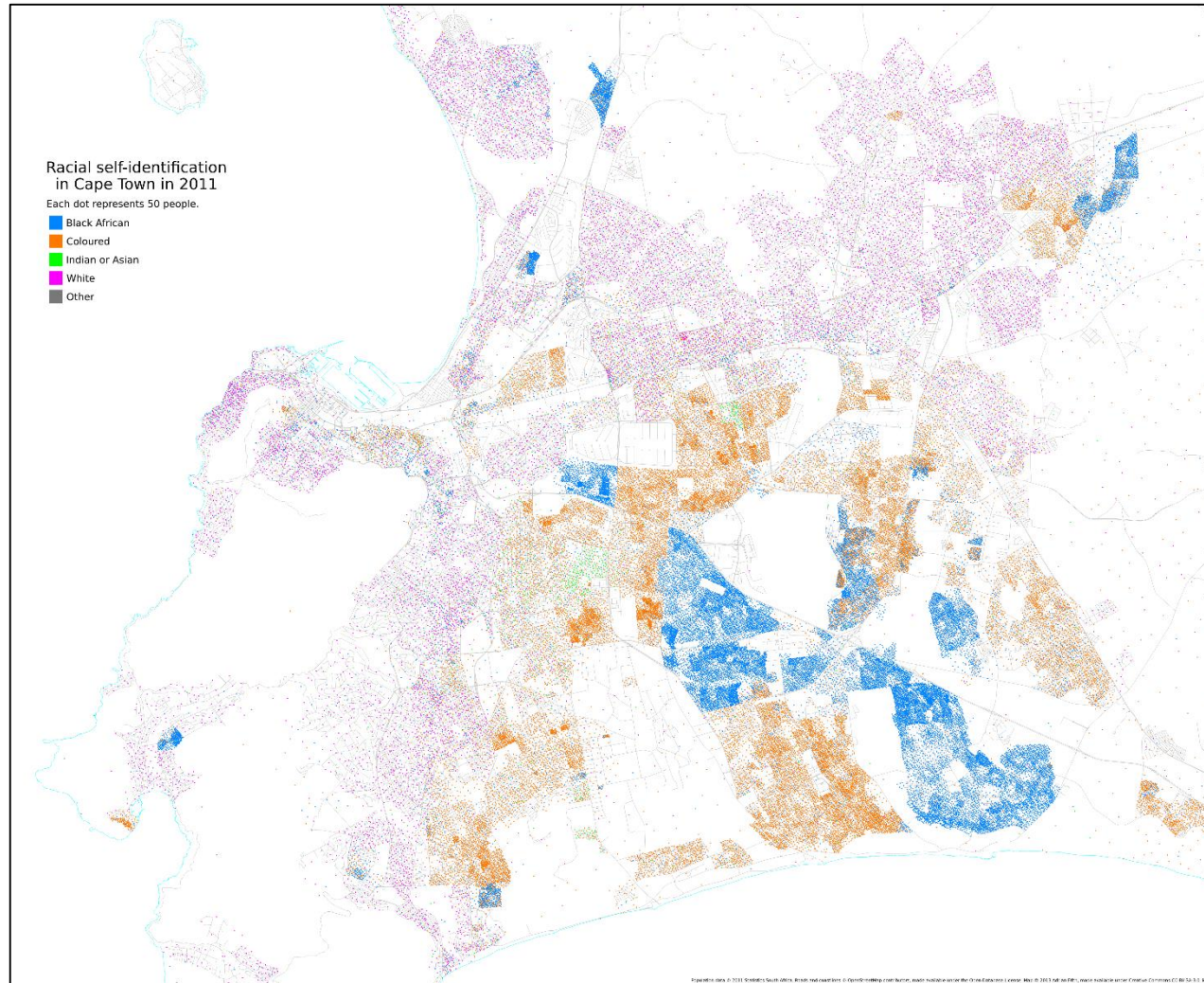
Yoneda, Y., 2010. *Inhabitat, "Shipping Container Rainforest Home Survives Category 5 Cyclone"*. [Online] Available at: <http://inhabitat.com/shipping-container-rainforest-home-survives-category-5-cyclone/> [Accessed 18 August 2013].

Zeiber, K. & Zeinor, J., 2012. *Alternative Construction Research Guide*, Biloxi, Mississippi: Gulf Coast Community Design Studio.

Zunguzane, N., Smallwood, J. & Emuze, F., 2012. Perceptions of the quality of low-income houses in South Africa: Defects and their causes. *Acta Structilia: Journal for the Physical and Development Sciences*, 19(1), pp. 19-38.

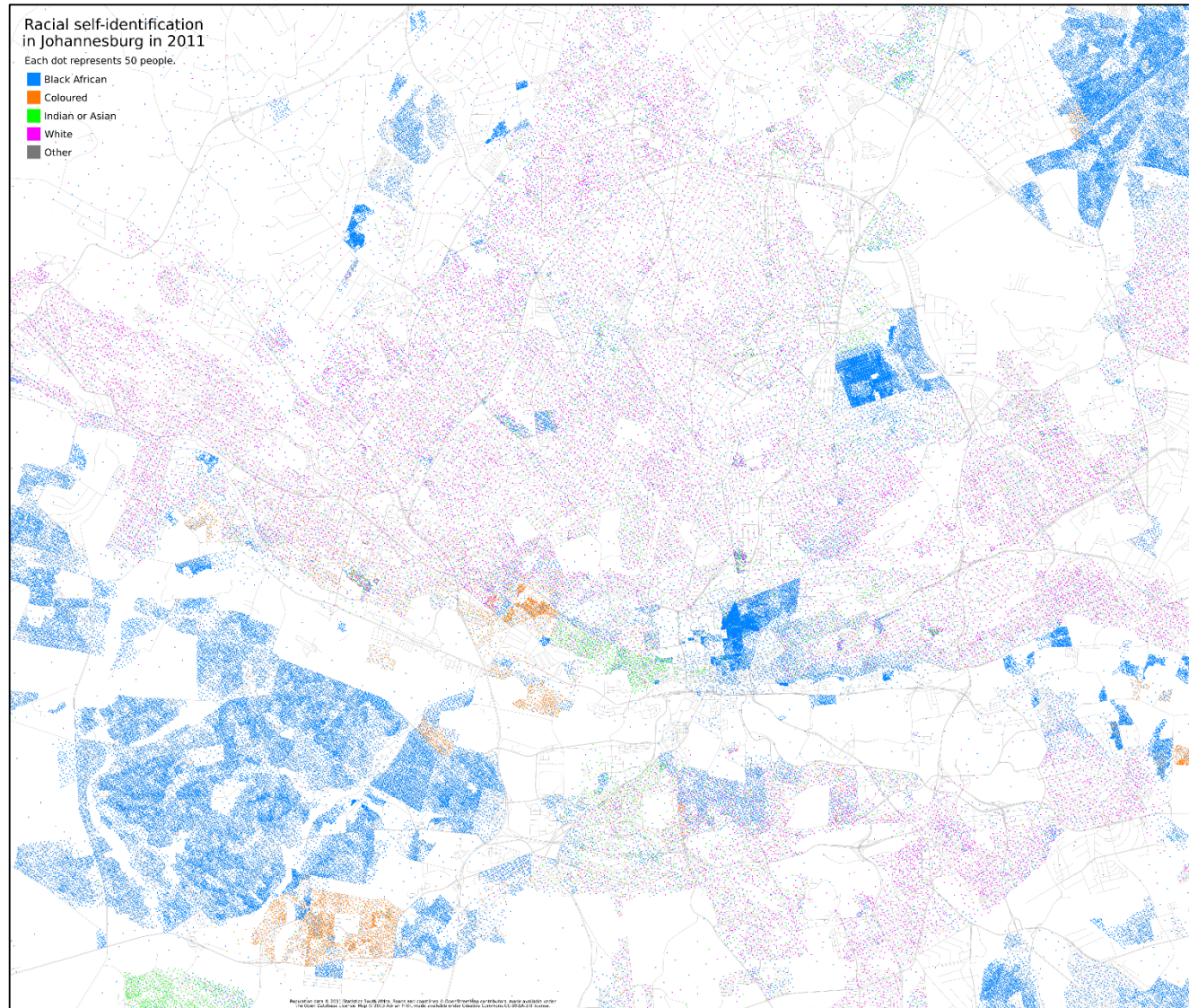
## **ANNEXURES**

**ANNEX A: RACIAL DISTRIBUTION ACCORDING TO 2011 CENSUS**



**Figure A1** Racial Identification in Cape Town According to Census 2011 Data (A. Firth, 2013)

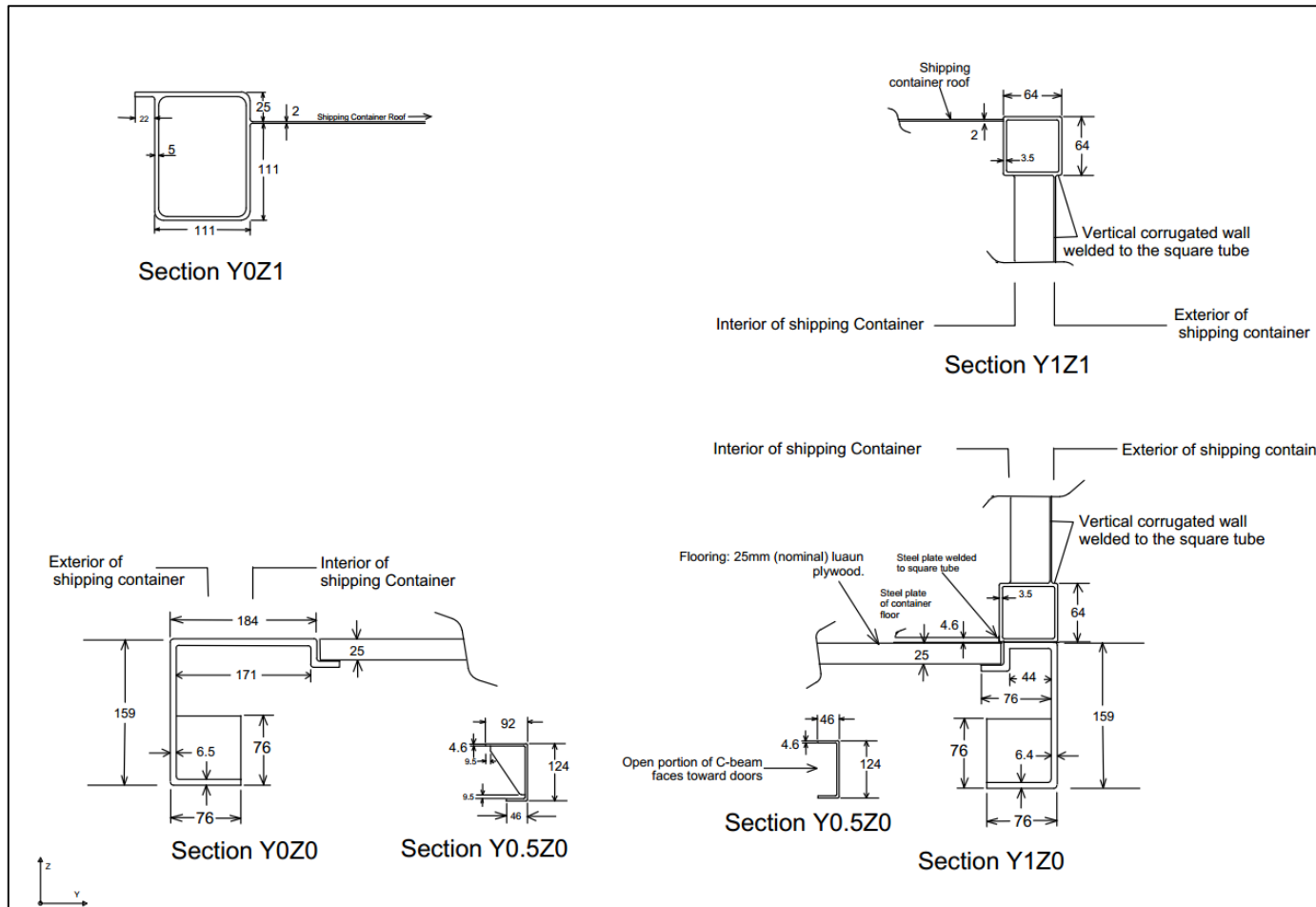




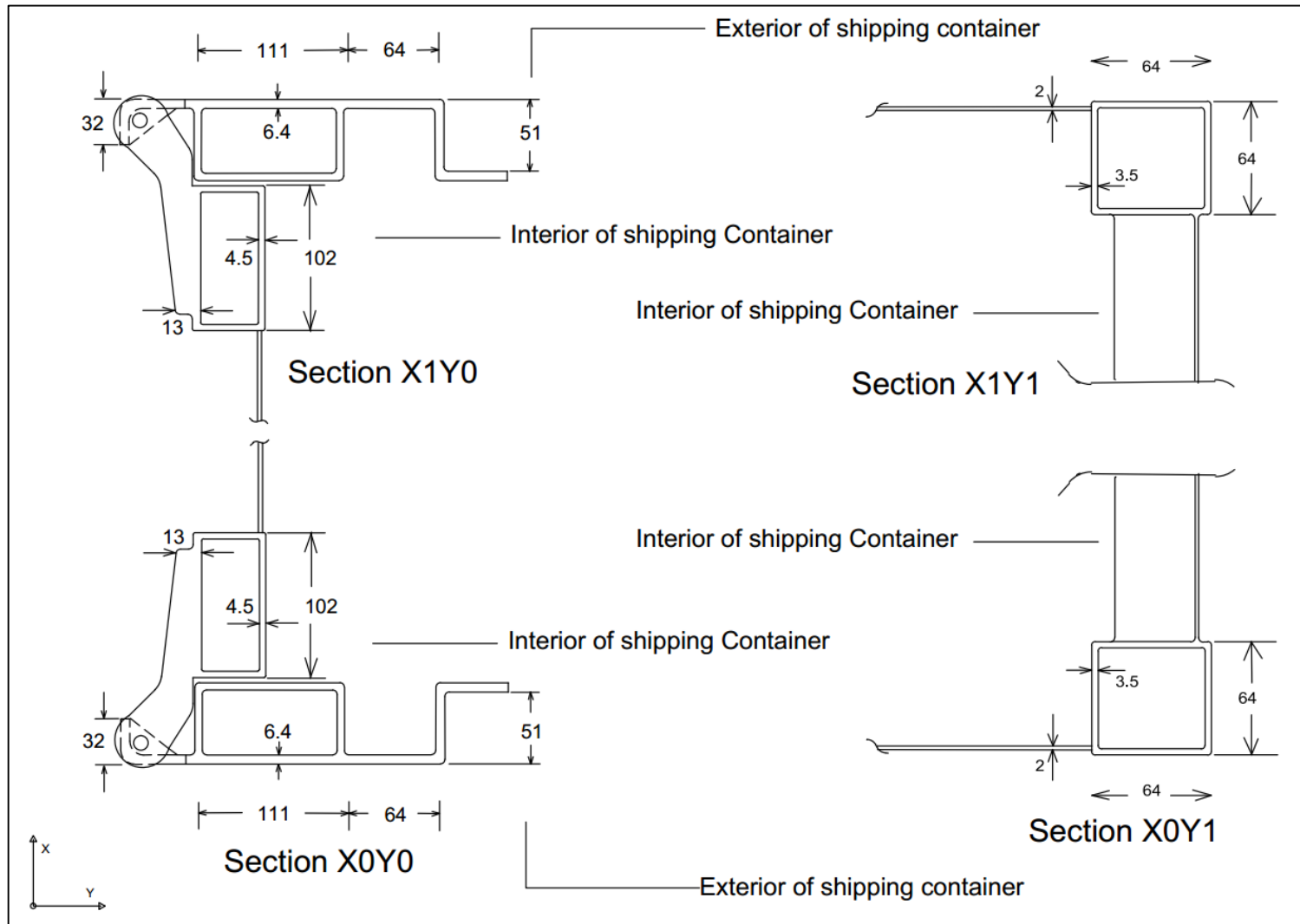
**Figure A2** Racial Identification in Johannesburg According to Census 2011 Data (A. Firth, 2013)



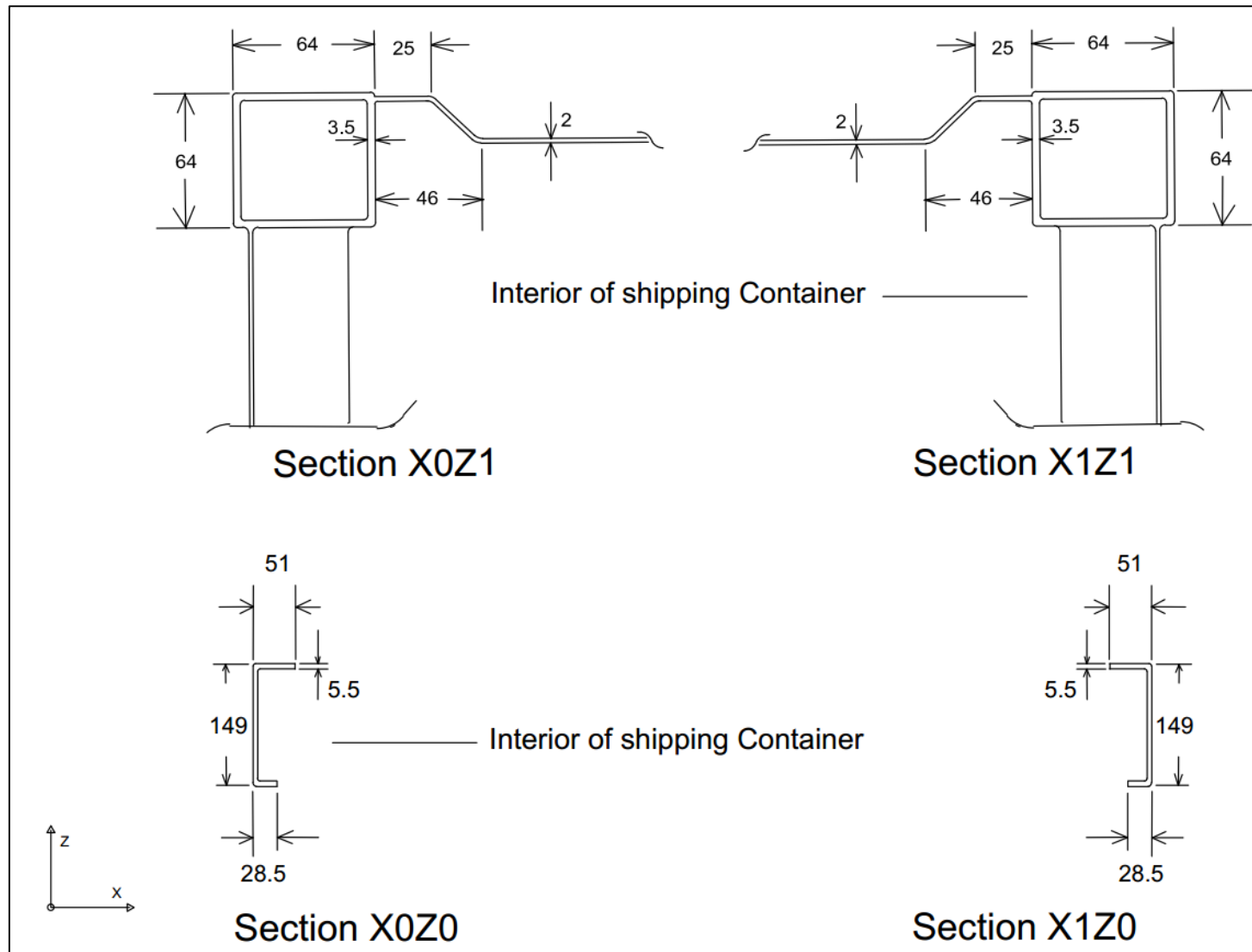
**ANNEX B: CONTAINER DRAWINGS AND FEA MODELLING DETAILS**



**Figure B1** YZ-Plane cross sections of beams for area and moment calculation.

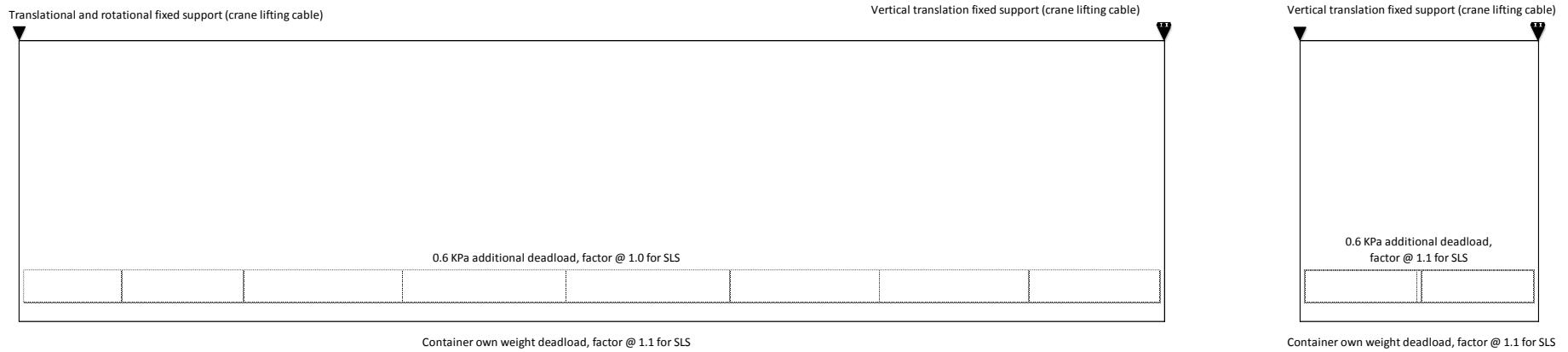


**Figure B2** XY-Plane cross sections of beams for area and moment calculation.

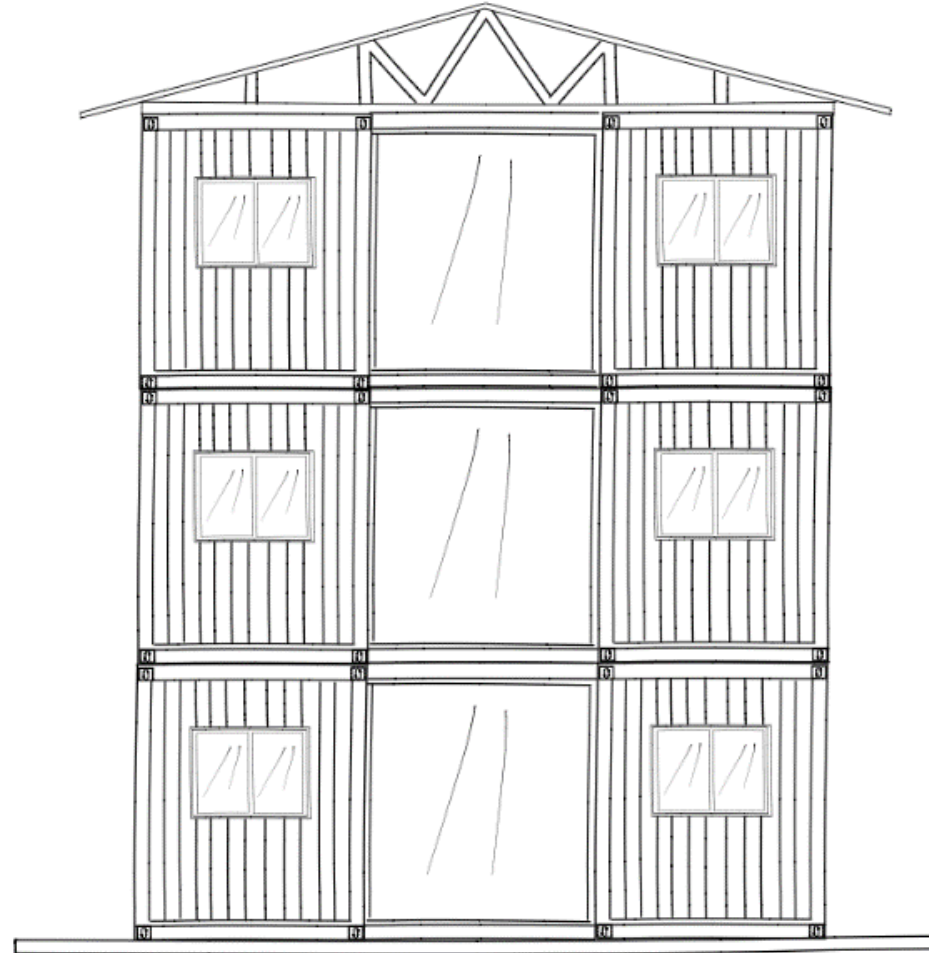


**Figure B3** XZ-Plane cross sections of beams for area and moment calculation.

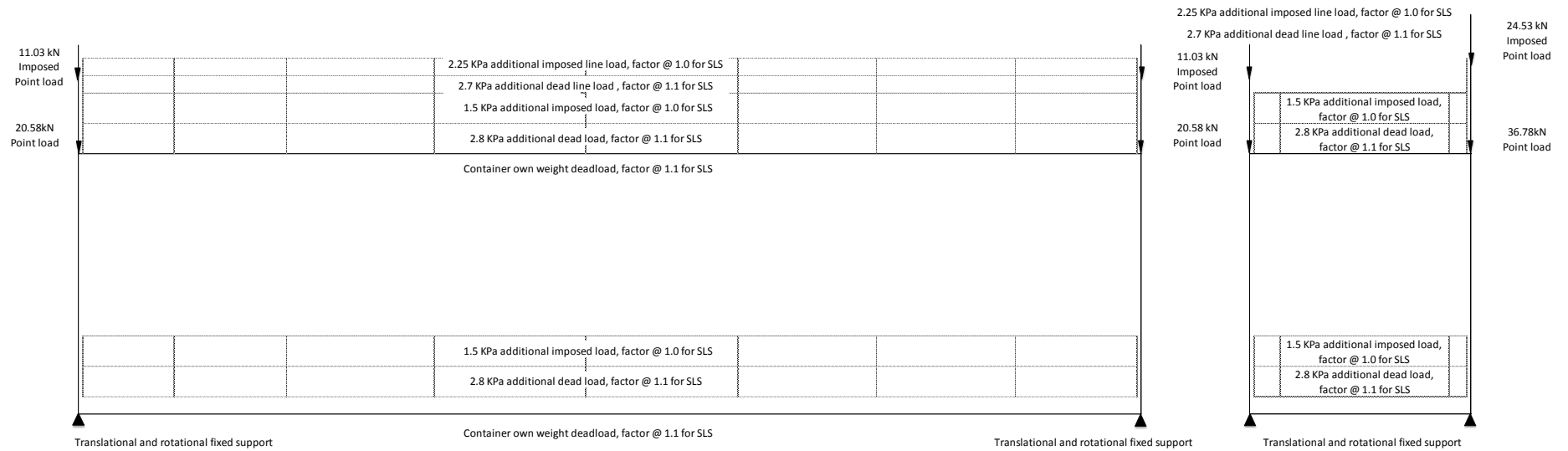
### ANNEX C: ISBU LIFTING FEM, LOAD CALCULATIONS



**Figure C** Supports and loads for deformation analysis, for the lifting case.

**ANNEX D: ISBU STATIC PERMA-LOAD FEM, LOAD CALCULATIONS**

**Figure D1** Deformation analysis load configuration for the static, permanent case.



**Figure D2** Supports and loads for deformation analysis, for the static, permanent case.

**ANNEX E: CONVENTIONAL BILL OF QUANTITIES**

BILL OF QUANTITIES, CONVENTIONAL DESIGN				Floor Area: 40 m <sup>2</sup>	
Item	Materials	Unit	Quantity	Rate	Total Cost
<b>Foundations</b>					
Excavation		m <sup>3</sup>	9.02	R 50.34	R 454.07
10MPa concrete foundation (600x200mm)		m <sup>3</sup>	3	R 1,040.00	R 3,120.00
190mm masonry units with brickforce, filled with concrete, 600mm depth		m <sup>2</sup>	14.9	R 103.04	R 1,535.30
					<b>R 4,361.10</b>
<b>Floor Slab</b>					
Dampcourse 250 micron		m <sup>2</sup>	41	R 5.93	R 243.13
25MPa concrete		m <sup>3</sup>	4.92	R 1,200.00	R 5,904.00
Steel mesh ref 193		m <sup>2</sup>	41	R 115.20	R 4,723.20
					<b>R 4,639.15</b>
<b>External Walls</b>					
Two top courses of brickwork to be filled with 10 Mpa concrete		m <sup>3</sup>	0.65		R 0.00
190mm masonry units		m <sup>2</sup>	75	R 205.01	R 15,375.75
Plaster externally (12mm thick		m <sup>2</sup>	75	R 32.51	R 2,438.25
					<b>R 17,814.00</b>
<b>Internal Walls</b>					
90mm masonry units		m <sup>2</sup>	26	R 132.00	R 3,432.00
Bagged plaster			52	R 12.24	R 636.48
					<b>R 4,068.48</b>
<b>Ceiling and Thermal Insulation</b>					
6.4 mm gypsum plaster board 50 mm glass wool laid to manufacturers specifications, finished with coverstrips (incl cornices)		m <sup>2</sup>	40	R 164.29	R 6,571.60
					<b>R 6,571.60</b>
<b>Windows and Doors</b>					
Steel frame window			6	R 1,431.00	R 8,586.00
Steel frame door			2	R 1,285.00	R 2,570.00
Wooden frame door			3	R 859.00	R 2,577.00
					<b>R 13,733.00</b>
<b>Roof and Covering</b>					
Howe Type Truss and erection		sum	1	R 4,553.14	R 4,553.14
114x38 SA Pine wall plates		m <sup>2</sup>	12	R 20.27	R 243.24
50x76mm SA Pine purlins at 1.2m spacing		sum	1	R 404.38	R 404.38
Treated galvanised steel sheeting		m <sup>2</sup>	46	R 168.39	R 7,745.94
Galvanised ridge cappings		m <sup>2</sup>	6	R 99.50	R 597.00
					<b>R 13,543.70</b>
<b>Transport (50km)</b>		sum	1	R 3,067.00	R 3,067.00
					<b>R 3,067.00</b>
<b>Price per household</b>					<b>R 67,798.03</b>
<b>Price per m<sup>2</sup></b>					<b>R 1,694.95</b>

**Figure E1** Conventional design Bill of Quantities (Adapted from C. Brewis).



**ANNEX F: ISBU BILL OF QUANTITIES**

<b>BILL OF QUANTITIES, ISBU SINGLE-STOREY DESIGN</b>					Floor Area:	96 m <sup>2</sup>
Item	Unit	Quantity	Rate	Total Cost		
<b>Foundations</b>						
Excavation	m <sup>3</sup>	21.12	R 50.34	R 1 063.18		
10MPa concrete foundation (600x200mm)	m <sup>3</sup>	4.776	R 1 040.00	R 4 967.04		
190mm masonry units with brickforce, filled with concrete, 600mm depth	m <sup>2</sup>	23.88	R 103.04	R 2 460.60		
				<b>R 8 490.82</b>		
<b>Floor Slabs and Infills</b>						
Dampcourse 250 micron	m <sup>2</sup>	98	R 5.93	R 581.14		
25MPa concrete	m <sup>3</sup>	14.76	R 1 200.00	R 17 712.00		
Steel mesh ref 617	m <sup>2</sup>	98	R 80.00	R 7 840.00		
10MPa concrete floor infill, containers	m <sup>3</sup>	9.48	R 1 040.00	R 9 859.20		
Steel mesh ref 193	m <sup>2</sup>	36	R 115.20	R 4 147.20		
				<b>R 40 139.54</b>		
<b>Container Delivery and Erection</b>						
Refurbished 12m container	ea	2	R 29 500.00	R 59 000.00		
Transport (50km)		2	R 2 350.00	R 4 700.00		
Mobile crane hire for project	/day	0.1	R 4 800.00	R 480.00		
				<b>R 64 180.00</b>		
<b>Insulation and Internal Walls</b>						
EPS insulated panels 1200mm and fixing	m <sup>2</sup>	302.32	R 121.50	R 36 731.88		
Shotcrete finish application	m <sup>2</sup>	206.26	R 72.00	R 14 850.72		
				<b>R 51 582.60</b>		
<b>Windows and Doors</b>						
Cutting + Steel frame window + Welding		6	R 2 660.00	R 15 960.00		
Cutting + Steel frame window + Welding		4	R 1 506.00	R 6 024.00		
Cutting + Steel frame door + Welding		2	R 1 385.00	R 2 770.00		
Wooden frame door		6	R 859.00	R 5 154.00		
				<b>R 29 908.00</b>		
<b>Roof Erection and covering</b>						
Fink Type Truss	ea	1	R 7 980.00	R 7 980.00		
50x76mm SA Pine purlins at 1.2m spacing	ea	1	R 930.08	R 930.08		
Galvanised steel sheeting	m <sup>2</sup>	102.92	R 168.39	R 17 330.70		
				<b>R 26 240.78</b>		
					<b>R 220 541.73</b>	
<b>Price per household</b>					<b>R 110 270.87</b>	
<b>Price per m<sup>2</sup></b>					<b>R 2 297.31</b>	

**Figure F1** ISBU single-storey design Bill of Quantities.

BILL OF QUANTITIES, ISBU MULTI-STOREY DESIGN				Floor Area:	288 m <sup>2</sup>
Item	Materials	Unit	Quantity	Rate	Total Cost
<b>Foundations</b>					
Excavation		m <sup>3</sup>	21.12	R 50.34	R 1 063.18
10MPa concrete foundation (600x200mm)		m <sup>3</sup>	4.776	R 1 040.00	R 4 967.04
190mm masonry units with brickforce, filled with concrete, 600mm depth		m <sup>2</sup>	23.88	R 103.04	R 2 460.60
					<b>R 8 490.82</b>
<b>Floor Slabs and Infills</b>					
Dampcourse 250 micron		m <sup>2</sup>	98	R 5.93	R 581.14
25MPa concrete		m <sup>3</sup>	14.76	R 1 200.00	R 17 712.00
Steel mesh ref 617		m <sup>2</sup>	98	R 80.00	R 7 840.00
10MPa concrete floor infill containers		m <sup>3</sup>	21.24	R 1 040.00	R 22 089.60
30MPa concrete floor slabs		m <sup>3</sup>	3.24	R 1 400.00	R 4 536.00
EPS perma-formwork		m <sup>2</sup>	36	R 303.75	R 10 935.00
Steel mesh ref 193		m <sup>2</sup>	108	R 115.20	R 12 441.60
					<b>R 76 135.34</b>
<b>Container Delivery and Erection</b>					
Refurbished 12m container		ea	6	R 29 500.00	R 177 000.00
Transport (50km)			6	R 2 350.00	R 14 100.00
Mobile crane hire for project		/day	0.3	R 4 800.00	R 1 440.00
					<b>R 192 540.00</b>
<b>Insulation and Internal Walls</b>					
EPS insulated panels 1200mm and fixing		m <sup>2</sup>	714.96	R 121.50	R 86 867.64
Shotcrete finish application		m <sup>2</sup>	618.78	R 72.00	R 44 552.16
					<b>R 131 419.80</b>
<b>Windows, Doors and Stairs</b>					
Cutting + Steel frame window + Welding			18	R 2 660.00	R 47 880.00
Cutting + Steel frame window + Welding			12	R 1 506.00	R 18 072.00
Cutting + Steel frame door + Welding			6	R 1 385.00	R 8 310.00
Wooden frame door			18	R 859.00	R 15 462.00
Steel stairwork 1.2m per floor			18	R 859.00	R 15 462.00
					<b>R 89 724.00</b>
<b>Roof Erection and covering</b>					
Fink Type Truss		ea	1	R 7 980.00	R 7 980.00
50x76mm SA Pine purlins at 1.2m spacing		ea	1	R 930.08	R 930.08
Galvanised steel sheeting		m <sup>2</sup>	102.92	R 336.78	R 34 661.40
					<b>R 43 571.48</b>
					<b>R 541 881.43</b>
<b>Price per household</b>					<b>R 90 313.57</b>
<b>Price per m<sup>2</sup></b>					<b>R 1 881.53</b>

Figure F2 ISBU multi-storey design Bill of Quantities.

**ANNEX G: SURVEY QUESTIONNAIRE**

Merk blokkie met 'n X / Mark block with an X	<b>DEEL 1/PART 1 :</b> <span style="float: right; font-weight: normal; font-size: small;">PERSONOOLIKE DETAILS PERSONAL DETAILS</span>	Page 1 Questionnaire No.: ..... Interviewer: .....																								
	<b>1. Ouderdom van Huiseienaar / Age of Homeowner</b> <input type="text"/> jaar oud / years old																									
	<b>2. Ras van Eienaar / Race of Owner</b>	<table border="1" style="width: 100%; border-collapse: collapse; font-size: small;"> <tr> <td style="text-align: center;">Kleurling/Coloured</td> <td style="text-align: center;">Swart / Black</td> <td style="text-align: center;">Wit / White</td> <td style="text-align: center;">Indiër / Indian</td> <td style="text-align: center;">Ander / Other</td> </tr> </table>	Kleurling/Coloured	Swart / Black	Wit / White	Indiër / Indian	Ander / Other																			
	Kleurling/Coloured	Swart / Black	Wit / White	Indiër / Indian	Ander / Other																					
	<b>3. Geloof / Religion</b>	<table border="1" style="width: 100%; border-collapse: collapse; font-size: small;"> <tr> <td style="text-align: center;">Christen/Christian</td> <td style="text-align: center;">Moslem / Muslim</td> <td style="text-align: center;">Atëis / Atheist</td> <td style="text-align: center;">Ander / Other</td> </tr> </table>	Christen/Christian	Moslem / Muslim	Atëis / Atheist	Ander / Other																				
	Christen/Christian	Moslem / Muslim	Atëis / Atheist	Ander / Other																						
	<b>4. Huwelikstatus / Marital status</b>	<table border="1" style="width: 100%; border-collapse: collapse; font-size: small;"> <tr> <td style="text-align: center;">Enkel / Single</td> <td style="text-align: center;">Paartjie / Couple</td> <td style="text-align: center;">Getroud / Married</td> <td style="text-align: center;">Geskei / Divorced</td> <td style="text-align: center;">Weduwee / Widowed</td> </tr> </table>	Enkel / Single	Paartjie / Couple	Getroud / Married	Geskei / Divorced	Weduwee / Widowed																			
	Enkel / Single	Paartjie / Couple	Getroud / Married	Geskei / Divorced	Weduwee / Widowed																					
	<b>5. Hoeveelheid mense wat leef in huis / Amount of people living in house</b>	5.1 Kinders / Children <input type="text"/> 5.2 Ander familie / Other family <input type="text"/> 5.3 Vriende / Friends <input type="text"/>																								
	<b>6. Vlak van onderrig / Education level</b>	<table border="1" style="width: 100%; border-collapse: collapse; font-size: small;"> <tr> <td style="text-align: center;">Ongeskool / Unschoolled</td> <td style="text-align: center;">Primêre Skool / Primary School</td> <td style="text-align: center;">Hoër Skool / High School</td> <td style="text-align: center;">Matriek / Matric</td> <td style="text-align: center;">Tersiêr / Tertiary</td> </tr> </table>	Ongeskool / Unschoolled	Primêre Skool / Primary School	Hoër Skool / High School	Matriek / Matric	Tersiêr / Tertiary																			
	Ongeskool / Unschoolled	Primêre Skool / Primary School	Hoër Skool / High School	Matriek / Matric	Tersiêr / Tertiary																					
<b>7. Werk status / Work status</b>	<table border="1" style="width: 100%; border-collapse: collapse; font-size: small;"> <tr> <td style="text-align: center;">Geen werk / Unemployed</td> <td style="text-align: center;">Het 1 werk / Has 1 job</td> <td style="text-align: center;">Het 2+ werke / Has 2+ jobs</td> </tr> </table>	Geen werk / Unemployed	Het 1 werk / Has 1 job	Het 2+ werke / Has 2+ jobs																						
Geen werk / Unemployed	Het 1 werk / Has 1 job	Het 2+ werke / Has 2+ jobs																								
<b>9. Inkomstevlak per maand/ Income level per month</b>	<table border="1" style="width: 100%; border-collapse: collapse; font-size: small;"> <tr> <td style="text-align: center;">R0-- R800</td> <td style="text-align: center;">R800-- R3500</td> <td style="text-align: center;">R3500-- R5000</td> <td style="text-align: center;">R5000-- R6500</td> <td style="text-align: center;">R6500-- R8000</td> <td style="text-align: center;">R8000-- R9500</td> <td style="text-align: center;">R9500-- R10500</td> <td style="text-align: center;">R10500+</td> </tr> </table>	R0-- R800	R800-- R3500	R3500-- R5000	R5000-- R6500	R6500-- R8000	R8000-- R9500	R9500-- R10500	R10500+																	
R0-- R800	R800-- R3500	R3500-- R5000	R5000-- R6500	R6500-- R8000	R8000-- R9500	R9500-- R10500	R10500+																			
<b>10. Huis tipe / Home type</b>	<table border="1" style="width: 100%; border-collapse: collapse; font-size: small;"> <tr> <td style="text-align: center;">Informele huis / Shack</td> <td style="text-align: center;">1 slaapkamer huis / bedroom house</td> <td style="text-align: center;">2 slaapkamer huis / bedroom house</td> <td style="text-align: center;">3+ slaapkamer huis / bedroom house</td> </tr> </table>	Informele huis / Shack	1 slaapkamer huis / bedroom house	2 slaapkamer huis / bedroom house	3+ slaapkamer huis / bedroom house																					
Informele huis / Shack	1 slaapkamer huis / bedroom house	2 slaapkamer huis / bedroom house	3+ slaapkamer huis / bedroom house																							
<b>11. Tipe vervoer tot by werk / Mode of travel to work</b>	<table border="1" style="width: 100%; border-collapse: collapse; font-size: small;"> <tr> <td style="text-align: center;">Loop / Walking</td> <td style="text-align: center;">Fiets / Bike</td> <td style="text-align: center;">Kar / Car</td> <td style="text-align: center;">Taxi</td> <td style="text-align: center;">Ander / Other</td> </tr> </table>	Loop / Walking	Fiets / Bike	Kar / Car	Taxi	Ander / Other																				
Loop / Walking	Fiets / Bike	Kar / Car	Taxi	Ander / Other																						
	<b>DEEL 2/PART 2 :</b> <span style="float: right; font-weight: normal; font-size: small;">VISUELE OPINIE VISUAL OPINION</span>																									
Kies A, B of A&B / Choose A, B, or A&B	<table border="1" style="width: 100%; border-collapse: collapse; font-size: small;"> <thead> <tr> <th style="width: 15%;">WYS / SHOW:</th> <th style="width: 60%;">VRA / ASK:</th> <th style="width: 25%;">ANTWOORD / ANSWER:</th> </tr> </thead> <tbody> <tr> <td>1. Foto 1 / Photo 1: <i>Bedrooms</i></td> <td>"Watter slaapkamer sal jy wil hê in 'n huis?" "Which <b>bedroom</b> would you want for a home?"</td> <td></td> </tr> <tr> <td>2. Foto 2 / Photo 2: <i>Bathrooms</i></td> <td>"Watter badkamer sal jy wil hê in 'n huis?" "Which <b>bathroom</b> would you want for a home?"</td> <td></td> </tr> <tr> <td>3. Foto 3 / Photo 3: <i>Living Rooms</i></td> <td>"Watter leefkamer sal jy wil hê in 'n huis?" "Which <b>living room</b> would you want for a home?"</td> <td></td> </tr> <tr> <td>4. Foto 4 / Photo 4: <i>Kitchens</i></td> <td>"Watter kombuis sal jy wil hê in 'n huis?" "Which <b>kitchen</b> would you want for a home?"</td> <td></td> </tr> <tr> <td>5. Foto 5 / Photo 5: <i>Topologies</i></td> <td>"Watter uitleg sal jy wil hê in 'n huis?" "Which <b>layout</b> would you like in a home?"</td> <td></td> </tr> <tr> <td>6. Foto 6 / Photo 6: <i>Outside front</i></td> <td>"Watter huis lyk mooi?" "Which <b>home is good-looking</b>?"</td> <td></td> </tr> <tr> <td>7. Foto 7 / Photo 7: <i>Overall</i></td> <td>"Watter huis sal jy in wil bly?" "Which <b>home</b> would you stay in?"</td> <td></td> </tr> </tbody> </table>	WYS / SHOW:	VRA / ASK:	ANTWOORD / ANSWER:	1. Foto 1 / Photo 1: <i>Bedrooms</i>	"Watter slaapkamer sal jy wil hê in 'n huis?" "Which <b>bedroom</b> would you want for a home?"		2. Foto 2 / Photo 2: <i>Bathrooms</i>	"Watter badkamer sal jy wil hê in 'n huis?" "Which <b>bathroom</b> would you want for a home?"		3. Foto 3 / Photo 3: <i>Living Rooms</i>	"Watter leefkamer sal jy wil hê in 'n huis?" "Which <b>living room</b> would you want for a home?"		4. Foto 4 / Photo 4: <i>Kitchens</i>	"Watter kombuis sal jy wil hê in 'n huis?" "Which <b>kitchen</b> would you want for a home?"		5. Foto 5 / Photo 5: <i>Topologies</i>	"Watter uitleg sal jy wil hê in 'n huis?" "Which <b>layout</b> would you like in a home?"		6. Foto 6 / Photo 6: <i>Outside front</i>	"Watter huis lyk mooi?" "Which <b>home is good-looking</b> ?"		7. Foto 7 / Photo 7: <i>Overall</i>	"Watter huis sal jy in wil bly?" "Which <b>home</b> would you stay in?"		
WYS / SHOW:	VRA / ASK:	ANTWOORD / ANSWER:																								
1. Foto 1 / Photo 1: <i>Bedrooms</i>	"Watter slaapkamer sal jy wil hê in 'n huis?" "Which <b>bedroom</b> would you want for a home?"																									
2. Foto 2 / Photo 2: <i>Bathrooms</i>	"Watter badkamer sal jy wil hê in 'n huis?" "Which <b>bathroom</b> would you want for a home?"																									
3. Foto 3 / Photo 3: <i>Living Rooms</i>	"Watter leefkamer sal jy wil hê in 'n huis?" "Which <b>living room</b> would you want for a home?"																									
4. Foto 4 / Photo 4: <i>Kitchens</i>	"Watter kombuis sal jy wil hê in 'n huis?" "Which <b>kitchen</b> would you want for a home?"																									
5. Foto 5 / Photo 5: <i>Topologies</i>	"Watter uitleg sal jy wil hê in 'n huis?" "Which <b>layout</b> would you like in a home?"																									
6. Foto 6 / Photo 6: <i>Outside front</i>	"Watter huis lyk mooi?" "Which <b>home is good-looking</b> ?"																									
7. Foto 7 / Photo 7: <i>Overall</i>	"Watter huis sal jy in wil bly?" "Which <b>home</b> would you stay in?"																									

**Figure G1** Page 1 of survey questionnaire, as used by the interviewer and respondent.

<b>DEEL 3/PART 3 :</b>		<b>OPINIE OOR EIENSKAPPE</b> <b>OPINION ON PROPERTIES</b>	Page 2
	EIENSKAP / FEATURE :	VRA / ASK :	ANTWOORD / ANSWER :
1.	Ruimtelike Persepsie / <i>Spatial Perception</i>	"Watter huis lyk <b>groot</b> aan die binnekant?" " <i>Which home looks <b>big</b> inside?</i> "	
2.	Hittebehoud / <i>Heat Retention</i>	"Watter huis lyk <b>koud</b> in die winter?" " <i>Which home looks <b>cold</b> in winter?</i> "	
3.	Waterdigtheid / <i>Waterproof</i>	"Watter huis lyk <b>lek</b> wanneer dit reën?" " <i>Which home <b>leaks</b> when it rains?</i> "	
4.	Klankdigtheid / <i>Soundproofing</i>	"Watter huis is <b>stil</b> ?" " <i>Which home is <b>quiet</b>?</i> "	
5.	Brandrisiko / <i>Fire Risk</i>	"Watter huis kan maklik <b>afbrand</b> ?" " <i>Which home can <b>burn down</b> easily?</i> "	
6.	Sekuriteit / <i>Security</i>	"Watter huis lyk <b>veilig</b> ?" " <i>Which home looks <b>safe</b>?</i> "	
7.	Duursaamheid / <i>Durability</i>	"Watter huis sal <b>lank bly staan</b> ?" " <i>Which home will <b>last long</b>?</i> "	
8.	Rigiditeit / <i>Rigidity</i>	"Watter huis lyk <b>sterk</b> gebou?" " <i>Which home looks <b>strong</b>?</i> "	
9.	Vakmanskap / <i>Workmanship</i>	"Watter huis lyk <b>goed gebou</b> ?" " <i>Which home looks <b>well built</b>?</i> "	
10.	Wagtyd / <i>Waiting Time</i>	"Watter huis word <b>vinnig gebou</b> ?" " <i>Which home is <b>built quickly</b>?</i> "	
11.	Modulariteit / <i>Modularity</i>	"Watter huis kan <b>maklik groter gemaak word</b> ?" " <i>Which home is <b>easy to make bigger</b>?</i> "	
12.	Binne Voorkoms / <i>Inside Appearance</i>	"Watter huis lyk <b>mooi aan die binnekant</b> ?" " <i>Which home is <b>best-looking on the inside</b>?</i> "	
13.	Buite Voorkoms / <i>Outside Appearance</i>	"Watter huis lyk <b>mooi aan die buitekant</b> ?" " <i>Which home is <b>best-looking on the outside</b>?</i> "	

DEEL 4/PART 4 : PERSEPSIE MET PERFEKTE INFORMASIE  
PERCEPTION WITH PERFECT INFORMATION

Wys Data Papier vir inwoner en wys verskil tussen Huis A en Huis B. VRA DAARNA:  
*Show Data Sheet to owner. Explain differences between House A and House B. THEN ASK:*

1. Watter huis lyk die mooiste (beste)? / *Which house is the best-looking?*

Huis A / House A	Huis B / House B
------------------	------------------

(Skryf kortliks / *Write briefly*)

2. Watter huis is beter om in te bly? / *Which house is better to stay in?*

Huis A / House A	Huis B / House B
------------------	------------------

(Skryf kortliks / *Write briefly*)

3. Sal jy in Huis B bly as dit meer soos 'n gewone huis lyk? / *Would you stay in House B if it looked like a normal house?*

JA / YES	NEE / NO
----------	----------

EINDE / END

**Figure G2** Page 2 of survey questionnaire, as used by the interviewer and respondent.

**ANNEX H: SURVEY PHOTOSHEETS**

	<p><b>FOTO 1/PHOTO 1</b> SLAAP KAMER VERGELYKING BED ROOM COMPARISON</p>	<p>Page 1 Interviewer: .....</p>				
<table style="width: 100%; border: none;"> <tr> <td style="width: 50%; border: none; padding: 5px;"> <p>TOETSGEVAL A / TEST CASE A</p>  </td> <td style="width: 50%; border: none; padding: 5px;"> <p>TOETSGEVAL B / TEST CASE B</p>  </td> </tr> </table>			<p>TOETSGEVAL A / TEST CASE A</p> 	<p>TOETSGEVAL B / TEST CASE B</p> 		
<p>TOETSGEVAL A / TEST CASE A</p> 	<p>TOETSGEVAL B / TEST CASE B</p> 					
<p>KIES EEN VAN DIE VOLGENDE: CHOOSE <b>ONE</b> OF THE FOLLOWING:</p>						
<table border="1" style="width: 100%; border-collapse: collapse;"> <tr> <td style="width: 25%; text-align: center; padding: 10px;">A</td> <td style="width: 25%; text-align: center; padding: 10px;">B</td> <td style="width: 25%; text-align: center; padding: 10px;">A en B / A and B</td> <td style="width: 25%; text-align: center; padding: 10px;">GEEN / NONE</td> </tr> </table>			A	B	A en B / A and B	GEEN / NONE
A	B	A en B / A and B	GEEN / NONE			
 <p><b>FOTO 2/PHOTO 2</b> BAD KAMER VERGELYKING BATH ROOM COMPARISON</p>		<p>Page 2</p>				
<table style="width: 100%; border: none;"> <tr> <td style="width: 50%; border: none; padding: 5px;"> <p>TOETSGEVAL A / TEST CASE A</p>  </td> <td style="width: 50%; border: none; padding: 5px;"> <p>TOETSGEVAL B / TEST CASE B</p>  </td> </tr> </table>			<p>TOETSGEVAL A / TEST CASE A</p> 	<p>TOETSGEVAL B / TEST CASE B</p> 		
<p>TOETSGEVAL A / TEST CASE A</p> 	<p>TOETSGEVAL B / TEST CASE B</p> 					
<p>KIES EEN VAN DIE VOLGENDE: CHOOSE <b>ONE</b> OF THE FOLLOWING:</p>						
<table border="1" style="width: 100%; border-collapse: collapse;"> <tr> <td style="width: 25%; text-align: center; padding: 10px;">A</td> <td style="width: 25%; text-align: center; padding: 10px;">B</td> <td style="width: 25%; text-align: center; padding: 10px;">A en B / A and B</td> <td style="width: 25%; text-align: center; padding: 10px;">GEEN / NONE</td> </tr> </table>			A	B	A en B / A and B	GEEN / NONE
A	B	A en B / A and B	GEEN / NONE			

**Figure H1** Page 1 and 2 of survey photosheets, as shown to the respondent.



**FOTO 3/PHOTO 3** LEEF KAMER VERGELYKING  
LIVING ROOM COMPARISON

Page 3

**TOETSGEVAL A / TEST CASE A**



**TOETSGEVAL B / TEST CASE B**



KIES EEN VAN DIE VOLGENDE:  
CHOOSE **ONE** OF THE FOLLOWING:

A	B	A en B / <i>A and B</i>	GEEN / NONE
---	---	----------------------------	----------------

**FOTO 4/PHOTO 4** KOMBUIS VERGELYKING  
KITCHEN COMPARISON

Page 4

**TOETSGEVAL A / TEST CASE A**



**TOETSGEVAL B / TEST CASE B**



KIES EEN VAN DIE VOLGENDE:  
CHOOSE **ONE** OF THE FOLLOWING:

A	B	A en B / <i>A and B</i>	GEEN / NONE
---	---	----------------------------	----------------

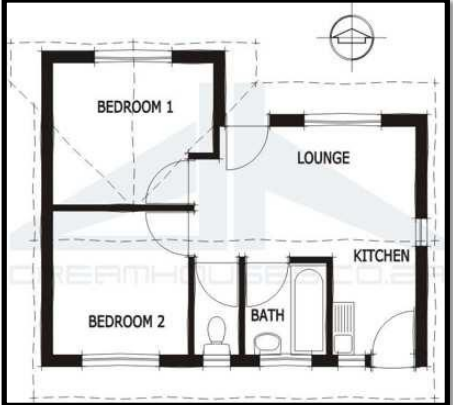
**Figure H2** Page 3 and 4 of survey photosheets, as shown to the respondent.

FOTO 5/PHOTO 5


UITLEG VERGELYKING  
 LAYOUT COMPARISON

Page 5

**TOETSGEVAL A / TEST CASE A**



**TOETSGEVAL B / TEST CASE B**



KIES EEN VAN DIE VOLGENDE:  
 CHOOSE **ONE** OF THE FOLLOWING:


A	B	A en B / <i>A and B</i>	GEEN / NONE
---	---	----------------------------	----------------

FOTO 6/PHOTO 6


BUITEKANT VERGELYKING  
 OUTSIDE COMPARISON

Page 6

**TOETSGEVAL A / TEST CASE A**



**TOETSGEVAL B / TEST CASE B**






KIES EEN VAN DIE VOLGENDE:  
 CHOOSE **ONE** OF THE FOLLOWING:

A	B	A en B / <i>A and B</i>	GEEN / NONE
---	---	----------------------------	----------------

**Figure H3** Page 5 and 6 of survey photosheets, as shown to the respondent.



	<b>FOTO 7/PHOTO 7</b> ALGEHELE VERGELYKING OVERALL COMPARISON	Page 7		
<p><b>TOETSGEVAL A / TEST CASE A</b></p> 	<p><b>TOETSGEVAL B / TEST CASE B</b></p> 			
KIES <b>EEN</b> VAN DIE VOLGENDE: CHOOSE <b>ONE</b> OF THE FOLLOWING:	A	B	A en B / <i>A and B</i>	GEEN / NONE

**Figure H4** Page 7 of survey photosheets, as shown to the respondent.

**ANNEX I: SURVEY INFORMATION SHEETS**

**S DATA PAPIER 1 / DATA SHEET 1 :** Page 1  
Interviewer: .....

**TOETSGEVAL A - Tradisionele Baksteenhuis / TEST CASE A: Traditional Brick and Mortar House**



**VOORDELE / ADVANTAGES**

- ✓ Gebou met bakstene / *Built with bricks*
- ✓ Goedkoop om te bou / *Cheap to build*
- ✓ Maklik om te bou / *Easy to build*
- ✓ Klankdig / *soundproof*
- ✓ Lyk groter in die binnekant / *Looks bigger inside*
- ✓ Lyk soos 'n huis / *Looks like a house*

**NADELE / DISADVANTAGES**

- ✗ Kouer in die winter / *colder in winter*
- ✗ Vat lank om te bou, 30 dae / *Takes long to build, 30 days*
- ✗ Kan sleg gebou word / *Can be badly built*
- ✗ Kort leeftyd / *Short lifetime*
- ✗ Nie baie sterk nie / *Not very strong*
- ✗ Kan lek wanneer dit reën / *Can leak when it rains*
- ✗ Kan maklik brand / *Can burn easily*
- ✗ Kleiner huis / *Smaller house*

**S DATA PAPIER 2 / DATA SHEET 2 :** Page 2

**TOETSGEVAL B - Alternatiewe Container Huis / TEST CASE B: Alternative Container House**



**VOORDELE / ADVANTAGES**

- ✓ Warm in die winter / *Warm in winter*
- ✓ Word vinnig gebou, 5 dae / *Is built quickly, 5 days*
- ✓ Baie maklik om te bou / *Very easy to build*
- ✓ Moeilik om sleg te bou / *Difficult to build badly*
- ✓ Lang leeftyd / *Long lifetime*
- ✓ Baie sterk gebou / *Very strong building*
- ✓ Kan nie lek nie / *Cannot leak when it rains*
- ✓ Brand nie maklik nie / *Doesn't burn easily*
- ✓ Groter huis / *Bigger house*

**NADELE / DISADVANTAGES**

- ✗ Gebou met staal en foam / *Built with steel and foam*
- ✗ Is duurder om te bou / *Is more expensive to build*
- ✗ Is nie klankdig nie / *Isn't soundproof*
- ✗ Lyk klein van binne af / *Looks small from inside*
- ✗ Lyk nie soos 'n huis nie / *Doesn't look like a house*

**Figure I1** Page 1 and 2 of survey information sheets, as shown to the respondent.

**ANNEX J: ENVIRONMENTAL IMPACT CALCULATIONS**

BILL OF QUANTITIES, ISBU SINGLE-STOREY DESIGN				Floor Area: 96 m <sup>2</sup>													
Item	Materials	Unit	Quantity	Rate	Total Cost	EcolInvent Conversion			Carbon Footprint		Acidification Pot.		Resource Depletion		Waste Generation		
						EID Unit	Factor	Result	factors	per item	factors	per item	factors	per item	Production	Construction	
<b>Foundations</b>									<b>2848.93</b>		<b>8.24</b>		<b>20513.81</b>				
Excavation		m <sup>3</sup>	21.12	R 50.34	R 1,063.18				0.000000	0.00	0.000000	0.00	0.000000	0.00	0.00	0.00	0.00
10MPa conc. foundation(600x200mm)		m <sup>3</sup>	4.776	R 1,040.00	R 4,967.04	m <sup>3</sup>			264.100000	1261.34	0.506600	2.42	1512.390000	7223.17	23.72	113.30	343.87
Reinforcing(4xY12)		kg	163.98						1.684100	276.16	0.005700	0.93	26.895500	4410.32	0.28	45.41	6.40
190mm masonry units,		m <sup>2</sup>	23.88	R 103.04	R 2,460.60	kg	160.00	3820.80	0.121200	463.08	0.000300	1.15	0.817600	3123.89	0.02	57.31	573.69
brickforce (75x2.8mm)		m	199			kg	0.11	21.89	2.155500	47.18	0.007800	0.17	36.146900	791.26	0.72	15.80	0.00
galvanised		m <sup>2</sup>	7.35			m <sup>2</sup>			4.440100	32.63	0.284580	2.09	76.750680	564.12	0.28	2.04	0.00
filled with concrete		m <sup>3</sup>	2.91			m <sup>3</sup>			264.100000	768.53	0.506600	1.47	1512.390000	4401.05	23.72	69.03	209.52
<b>R 8,490.82</b>																	
<b>Floor Slabs and infills</b>									<b>6896.12</b>		<b>13.98</b>		<b>45445.97</b>				
Dampcourse 250 micron		m <sup>2</sup>	98	R 5.93	R 581.14	kg	0.23	22.54	2.608500	58.80	0.009800	0.22	81.185600	1829.92	0.06	1.32	0.00
25MPa concrete		m <sup>3</sup>	14.76	R 1,200.00	R 17,712.00	m <sup>3</sup>			264.100000	3898.12	0.506600	7.48	1512.390000	22322.88	23.72	350.15	1062.72
Steel mesh ref 193		m <sup>2</sup>	98	R 80.00	R 7,840.00	kg	1.93	189.14	1.684100	318.53	0.005700	1.08	26.895500	5087.01	0.28	52.37	3.82
10MPa Concrete floor in container		m <sup>3</sup>	9.48	R 1,040.00	R 9,859.20	m <sup>3</sup>			264.100000	2503.67	0.506600	4.80	1512.390000	14337.46	23.72	224.89	682.56
Steel mesh ref 193		m <sup>2</sup>	36	R 115.20	R 4,147.20	kg	1.93	69.48	1.684100	117.01	0.005700	0.40	26.895500	1868.70	0.28	19.45	1.40
<b>R 40,139.54</b>																	
<b>Container Delivery and Erection</b>									<b>2519.14</b>		<b>13.75</b>		<b>39965.37</b>				
Refurbished 12m container		ea	2	R 29,500.00	R 59,000.00				0.000000	0.00	0.000000	0.00	0.000000	0.00	0.00	0.00	0.00
Transport (50km)			4700	R 1.00	R 4,700.00	tkm			0.486320	2285.70	0.002655	12.48	7.715323	36262.02	0.04	185.51	0.00
Mobile crane hire for project		/day	480	R 1.00	R 480.00	tkm			0.486320	233.43	0.002655	1.27	7.715323	3703.36	0.04	19.20	0.00
<b>R 64,180.00</b>																	
<b>Insulation and Internal Walls</b>									<b>1702.29</b>		<b>3.02</b>		<b>24741.92</b>				
EPS insulated panels 1200mm and f		m <sup>2</sup>	302.32	R 121.50	R 36,731.88	kg	0.23	69.53	2.608500	788.60	0.009800	2.96	81.185600	24544.03	0.06	17.72	0.00
Shotcrete finish application		m <sup>2</sup>	206.26	R 72.00	R 14,850.72	kg	27.60	5692.78	0.160500	913.69	0.000300	0.06	0.959400	197.89	0.00	0.47	170.78
<b>R 51,582.60</b>																	
<b>Roof Erection and covering</b>									<b>1629.55</b>		<b>34.01</b>		<b>28719.28</b>				
Fink Type Truss		ea	1	R 7,980.00	R 7,980.00	m <sup>3</sup>		0.63	88.873000	55.99	0.554600	0.35	1337.828000	842.83	18.49	11.65	0.00
50x76mm SA Pine purlins at 1.2m sp		ea	1	R 930.08	R 930.08	m <sup>3</sup>		0.22	88.873000	19.55	0.554600	0.12	1337.828000	294.32	18.49	4.07	0.00
Galvanised steel sheeting		m <sup>2</sup>	102.92	R 168.39	R 17,330.70				4.440100	456.98	0.284580	29.29	76.750700	7899.18	0.28	28.60	0.00
anti-corrosive coating			102.92			kg	5.03	517.69	2.119100	1097.03	0.008200	4.25	38.020900	19682.95	0.69	71.01	0.00
<b>R 26,240.78</b>									<b>15596.03</b>		<b>73.00</b>		<b>159386.36</b>		<b>1289.33</b>	<b>3291.59</b>	<b>4345.61</b>
<b>R 220,541.73</b>																	
<b>Price per household</b>									<b>7798.016</b>		<b>36.49844</b>		<b>79693.18</b>		<b>644.663553</b>	<b>1645.79481</b>	<b>2172.803767</b>
<b>Price per m<sup>2</sup></b>																	
<b>R 2,297.31</b>																	

**Figure J** Tabulated environmental impact calculation for the single-storey ISBU test case.