

**The verification of  
Seat Effective Amplitude Transmissibility (SEAT)  
value  
as a reliable metric to evaluate dynamic seat comfort**

**Anriëtte van der Westhuizen**

Supervisor: Prof JL van Niekerk



Dissertation presented for the Degree of Master of Engineering at the  
University of Stellenbosch.

**December  
2004**

# Declaration

I, the undersigned, hereby declare the work contained in this dissertation is my own original work and that I have not previously in its entirety or in part submitted it at any university for a degree.

*Signature:*\_\_\_\_\_

*Date:*\_\_\_\_\_

## Abstract

A rough road vibration stimulus was reconstructed on a shaker platform to assess the dynamic comfort of seven seats by six human subjects. The virtual seat method was combined with a paired comparison procedure to assess subjective dynamic seat comfort. The psychometric method of constants, 1-up-1-down Levitt procedure and a 2-up-1-down Levitt procedure were compared experimentally to find the most accurate and efficient paired comparison scheme. A two-track interleaved, 2-up-1-down Levitt procedure was used for the subjective dynamic seat comfort assessment. SEAT value is an objective metric and has been widely used to determine seat vibration isolation efficiency. There was an excellent correlation ( $R^2 = 0.97$ ) between the subjective ratings and estimated SEAT values on the seat top when the values are averaged over the six subjects. This study suggests that the SEAT values, estimated from averaged seat top transmissibility of six carefully selected subjects, could be used to select the best seat for a specific road vibration input.

## Opsomming

Ses persone het deelgeneem aan 'n eksperiment, om die dinamiese ritgemak van sewe stoele te karakteriseer. 'n Rowwe padvibrasie is vir die doel op 'n skudplatform geherkonstrueer. Subjektiewe ritgemak is bepaal deur die virtuelestoel metode met 'n gepaarde, vergelykingstoets te kombineer. Die psigometriese metode van konstantes, die 1-op-1-af Levitt procedure en die 2-op-1-af Levitt procedure is vergelyk om die mees effektiewe en akkurate vergelykingstoets te vind. 'n Tweebaar, vervlegde, 2-op-1-af Levitt procedure het die beste resultate gelever en is gekies vir die subjektiewe evaluasie van dinamiese ritgemak. SEAT-waarde is 'n objektiewe maatstaf, wat gebruik word om te bepaal hoe effektief 'n stoel die insittende van voertuigvibrasie isoleer. Daar was 'n uitstekende korrelasie ( $R^2 = 0.97$ ) tussen subjektiewe dinamiese ritgemakevaluasies en SEAT-waardes in die vertikale rigting op die stoelkussing as die gemiddelde oor die ses persone bereken word. Uit die resultate van hierdie studie blyk dit dat SEAT-waardes, wat bereken is vanaf die gemiddelde sitplektransmissie van die ses persone, wat verteenwoordigend van die teikenbevolking is, gebruik kan word om die beste stoel vir 'n spesifieke vibrasieinset te kies.

*Dedicated to God who has given us life in abundance....*

# Acknowledgements

The author thanks Ford Motor Company for their sponsorship throughout this project and an unforgettable visit to the Ford Research Laboratory in Dearborn. I am grateful to Dr. Bill Pielemeier for invaluable correspondence and technical advice.



It has been the author's good fortune to work at the University of Stellenbosch. Without the support of fellow students and lecturers the start and completion of this dissertation would not be possible.

Johnita Theunissen, Ilse du Toit, Jessica Gunaselvam, Hannes Pretorius, Marco Burger, Corné Coetzee, Jacques Dymond, Paul Wipplinger and Charl Goussard for their enthusiastic participation in dynamic seat comfort tests.

Ferdi Zietsman, Cobus Zietsman and Ockert Strijdom for their assistance with laboratory work and Noël du Toit for writing the challenging control programs for the DSTF.

The greatest thanks to Prof Wikus van Niekerk for inspirational mentorship.



Magdaleen and Wessie van der Westhuizen for their ceaseless love and encouragement.

# Table of contents

Declaration	i
Abstract	ii
Opsomming	iii
Acknowledgements	v
Glossary	xx
<b>1. Introduction</b>	<b>1</b>
<b>2. Literature survey</b>	<b>4</b>
Vibration measurement standards	4
Experimental techniques and measurement	8
Seat transmissibility	11
Seat effective amplitude transmissibility (SEAT) values	13
Subjective dynamic seat comfort assessment	17
The use of seat effective amplitude transmissibility values to predict seat comfort [ <i>Van Niekerk, 2002</i> ]	28
2.7 Conclusions from the literature survey	30
<b>3. Experimental rig</b>	<b>31</b>
The dynamic seat testing facility (DSTF)	31
Frequency response of the DSTF	36
Test seats	39
Test subjects	41
Seat position and vibration measurement	42
Test stimuli	45
Conclusions on the experimental rig	56

<b>4. Subjective testing procedures</b>	<b>58</b>
The Levitt adaptive procedure	58
Experimental comparison of subjective dynamic seat comfort assessment procedures	66
Conclusion of subjective procedure test results	74
<b>5. The dynamic seat comfort assessment procedure</b>	<b>76</b>
5.1 Subject preparation	76
5.2 Reference signal and alternative stimuli signals	77
5.3 Subjective dynamic seat comfort assessment	81
5.4 Objective data for SEAT value calculation	82
5.5 Test procedure conclusions	83
<b>6. Discussion of results</b>	<b>84</b>
6.1 Subjective dynamic seat comfort results	85
6.2 Objective dynamic seat comfort results	88
6.3 Correlation between subjective and objective dynamic seat comfort	92
6.4 Seat transmissibility results	97
6.5 Estimated SEAT values	102
6.6 Further observations on SEAT values	105
<b>7. Conclusions &amp; future work</b>	<b>108</b>
<b>8. References</b>	<b>115</b>



# Appendices

<b>A. Characterisation of the experimental rig</b>	<b>119</b>
A.1 DSTF vibration characteristics in the 0 – 20 Hz range	119
<b>B. Steps of the dynamic seat comfort assessment procedure</b>	<b>124</b>
B.1 Prepare seat and position accelerometers	124
B.2 Prepare subject	125
B.3 Measure seat transmissibility functions	126
B.4 Measure frequency response functions	127
B.5 Reference and alternative stimuli files	127
B.6 Subjective seat comfort assessment	129
B.7 Collect data for SEAT value calculation	129
<b>C. Levitt procedure trial histories</b>	<b>131</b>
C.1 Seat A	131
C.2 Seat B	132
C.3 Seat C	133
C.4 Seat D	134
C.5 Seat E	135
C.6 Seat F	136
C.7 Seat G	137
<b>D. Acceleration r.m.s. values of data used for SEAT value calculation</b>	<b>138</b>
<b>E. Seat transmissibility measurements</b>	<b>141</b>

E.1 Seat A	141
E.2 Seat B	143
E.3 Seat C	145
E.4 Seat D	147
E.5 Seat E	149
E.6 Seat F	151
E.7 Seat G	153

# List of figures

- 2.1 A semi-rigid mounting disk used for seat pad accelerometers
- 2.2 (a) Suggested [*ISO 7096, 2000*] and  
(b) Actual test person posture
- 2.3 A seat index point (SIP) gauge
- 2.4 The basicentric axis system for whole-body vibration measurement of a seated person [*ISO 2631:1, 1997*]
- 2.5 Frequency weighting for principle weightings [*ISO 2631:1, 1997*]
- 2.6 Subjective dynamic comfort rating on a 100 mm line [*Parsons and Griffin, 1983*]
- 2.7 Psychometric function for difference threshold determination [*Greenberg et al., 1999*]
- 2.8 Psychometric plot for a typical case [*Greenberg et al., 1999*]
- 2.9 The PSD of the *virtual reference* [*Van Niekerk et al., 2002*]
  
- 3.1 Diagram of the dynamic seat testing facility
- 3.2 (a) The aluminium extrusion bars create a versatile sliding system  
(b) To which test seats are bolted  
(c) At the seat track
- 3.3 (a) Transmissibility and  
(b) Coherence of input displacement vs. LVDT displacement for different input levels
- 3.4 (a) Frequency response and  
(b) Coherence of input displacement and the acceleration of the platform centre for different input levels
- 3.5 Seat A, B, C, E, F and G
- 3.6 (a) Seat D  
(b) Middle and top sections of the rigid wooden seat
- 3.7 Consistent seat location parameters
- 3.8 Seat measurement locations

- 3.9 The profile of the FFT of a displacement signal that results in an acceleration signal with a flat FFT profile
- 3.10 Calculated vs. actual input displacement spectra
- 3.11 (a) Actual PSD of LVDT displacement and  
(b) Platform acceleration during transmissibility & FRF measurement
- 3.12 Measured system transmissibility and FRFs
- 3.13 Measured seat transmissibility functions and magnitudes
- 3.14 (a) The Opel Corsa 1.3 L Lite and the  
(b) Badly corrugated gravel road between Hangklip and Betties Bay, Western Cape
- 3.15 Diagram of accelerometer placement for road data recording
- 3.16 The 5 s vibration approximation chosen from the Corsa floor-pan vibration
- 3.17 (a) The band-pass filter applied to road vibration recordings and  
(b) The filtered and unfiltered signal PSDs
- 3.18 (a) Calculated vs. windowed input displacements for reproducing the  
(b) Desired and reconstructed floor-pan vibration on the DSTF platform
- 3.19 (a) Reconstruction of the *reference vibration* for different subjects in the time domain and the  
(b) Frequency domain
  
- 4.1 A Levitt procedure with constant step size
- 4.2 A four-track interleaved Levitt procedure [*Bellmann, 2000*]
- 4.3 2-up-1-down, interleaved Levitt procedure
- 4.4 Diagram of stimuli scaling
- 4.5 A psychometric function probability plot
- 4.6 A two-track, interleaved Levitt procedure
- 4.7 A 2-up-1-down, two-track interleaved Levitt procedure with an initial step size of 4 JNDs
- 4.8 (a) 2-up-1-down, two-track interleaved, Levitt procedure with an initial step size of 6 JNDs  
(b) 8 JNDs

- 5.1 Scaling of the *alternative stimuli* for 2-up-1-down, Levitt subjective dynamic seat comfort assessment procedure
- 5.2 Input file structure for the 2-up-1-down, Levitt subjective dynamic seat comfort assessment procedure
  
- 6.1 Averaged subjective ratings from the Kolich survey
- 6.2 Subjective comfort ratings from paired comparison tests
- 6.3 Subjective dynamic seat comfort ranking
- 6.4 (a) Objective dynamic seat comfort ranking according to SEAT values on the seat top
  - (b) Seatback in-plane and
  - (c) Seatback perpendicular
- 6.5 The correlation between dynamic comfort indices determined with the Kolich survey and SEAT value
- 6.6 Correlation between individual measured SEAT values (vertical track input to vertical output at the seat top) and the individual subjective ratings
- 6.7 Correlation of all the individual SEAT values with subjective comfort ratings (40 points)
- 6.8 Average SEAT values for test seats (7 points)
- 6.9 (a) Average seat top transmissibility and
  - (b) Coherence
- 6.10 Squared average seat top transmissibility and *reference vibration* PSD
- 6.11 (a) Average seat transmissibility of Seat C
  - (b) Seat B and
  - (c) Seat D between 4 and 8 Hz with marked energy peaks in the *reference vibration* PSD
- 6.12 (a) Average transmissibility and
  - (b) Coherence of the seatback in-plane and platform acceleration
- 6.13 (a) Average seatback perpendicular transmissibility and
  - (b) Coherence
- 6.14 (a) Correlation between calculated and estimated SEAT value on the seat top
  - (b) in-plane seatback and
  - (c) perpendicular seatback

- 6.15 Comparison of measured and estimated SEAT values during subjective dynamic seat comfort assessment
- 6.16 SEAT values at different vibration magnitudes
  
- A.1 Top view of the platform with sensor locations for DSTF modal tests
- A.2 (a) Transmissibility and  
(b) Coherence of vertical platform centre vibration (location 1) vs. platform front vibration (location 2)
- A.3 (a) Transmissibility and  
(b) Coherence of vertical platform centre vibration (location 1) vs. platform side vibration (location 3)
- A.4 (a) Transmissibility and  
(b) Coherence of vertical platform centre (location 1) vs. footplate centre vibration (location 4)
  
- C.1 (a) 2-up-1-down Levitt procedure trial histories for Subject 1,  
(b) Subject 2,  
(c) Subject 3,  
(d) Subject 4,  
(e) Subject 5 and  
(f) Subject 6 on Seat A
- C.2 (a) 2-up-1-down Levitt procedure trial histories for Subject 1,  
(b) Subject 2,  
(c) Subject 3,  
(d) Subject 4,  
(e) Subject 5 and  
(f) Subject 6 on Seat B
- C.3 (a) 2-up-1-down Levitt procedure trial histories for Subject 1,  
(b) Subject 2,  
(c) Subject 3,  
(d) Subject 6 on Seat C

- C.4 (a) 2-up-1-down Levitt procedure trial histories for Subject 1,  
(b) Subject 2,  
(c) Subject 3,  
(d) Subject 4,  
(e) Subject 5 and  
(f) Subject 6 on Seat D
- C.5 (a) 2-up-1-down Levitt procedure trial histories for Subject 1,  
(b) Subject 2,  
(c) Subject 3,  
(d) Subject 4,  
(e) Subject 5 and  
(f) Subject 6 on Seat E
- C.6 (a) 2-up-1-down Levitt procedure trial histories for Subject 1,  
(b) Subject 2,  
(c) Subject 3,  
(d) Subject 4,  
(e) Subject 5 and  
(f) Subject 6 on Seat F
- C.7 (a) 2-up-1-down Levitt procedure trial histories for Subject 1,  
(b) Subject 2,  
(c) Subject 3,  
(d) Subject 4,  
(e) Subject 5 and  
(f) Subject 6 on Seat G
  
- E.1 (a) Seat top transmissibility of Seat A at  $0.5 \text{ m/s}^2$ ,  
(b)  $1 \text{ m/s}^2$ ,  
(c)  $1.5 \text{ m/s}^2$  and  
(d)  $2 \text{ m/s}^2$
- E.2 (a) Seatback in-plane transmissibility of Seat A at  $0.5 \text{ m/s}^2$ ,  
(b)  $1 \text{ m/s}^2$ ,  
(c)  $1.5 \text{ m/s}^2$  and  
(d)  $2 \text{ m/s}^2$

- E.3 (a) Seatback perpendicular transmissibility of Seat A at  $0.5 \text{ m/s}^2$ ,  
(b)  $1 \text{ m/s}^2$ ,  
(c)  $1.5 \text{ m/s}^2$  and  
(d)  $2 \text{ m/s}^2$
- E.4 (a) Seat top transmissibility of Seat B at  $0.5 \text{ m/s}^2$ ,  
(b)  $1 \text{ m/s}^2$ ,  
(c)  $1.5 \text{ m/s}^2$  and  
(d)  $2 \text{ m/s}^2$
- E.5 (a) Seatback in-plane transmissibility of Seat B at  $0.5 \text{ m/s}^2$ ,  
(b)  $1 \text{ m/s}^2$ ,  
(c)  $1.5 \text{ m/s}^2$  and  
(d)  $2 \text{ m/s}^2$
- E.6 (a) Seatback perpendicular transmissibility of Seat B at  $0.5 \text{ m/s}^2$ ,  
(b)  $1 \text{ m/s}^2$ ,  
(c)  $1.5 \text{ m/s}^2$  and  
(d)  $2 \text{ m/s}^2$
- E.7 (a) Seat top transmissibility of Seat C at  $0.5 \text{ m/s}^2$ ,  
(b)  $1 \text{ m/s}^2$ ,  
(c)  $1.5 \text{ m/s}^2$  and  
(d)  $2 \text{ m/s}^2$
- E.8 (a) Seatback in-plane transmissibility of Seat C at  $0.5 \text{ m/s}^2$ ,  
(b)  $1 \text{ m/s}^2$ ,  
(c)  $1.5 \text{ m/s}^2$  and  
(d)  $2 \text{ m/s}^2$
- E.9 (a) Seatback perpendicular transmissibility of Seat C at  $0.5 \text{ m/s}^2$ ,  
(b)  $1 \text{ m/s}^2$ ,  
(c)  $1.5 \text{ m/s}^2$  and  
(d)  $2 \text{ m/s}^2$
- E.10 (a) Seat top transmissibility of Seat D at  $0.5 \text{ m/s}^2$ ,  
(b)  $1 \text{ m/s}^2$ ,  
(c)  $1.5 \text{ m/s}^2$  and  
(d)  $2 \text{ m/s}^2$



- E.11 (a) Seatback in-plane transmissibility of Seat D at  $0.5 \text{ m/s}^2$ ,  
(b)  $1 \text{ m/s}^2$ ,  
(c)  $1.5 \text{ m/s}^2$  and  
(d)  $2 \text{ m/s}^2$
- E.12 (a) Seatback perpendicular transmissibility of Seat D at  $0.5 \text{ m/s}^2$ ,  
(b)  $1 \text{ m/s}^2$ ,  
(c)  $1.5 \text{ m/s}^2$  and  
(d)  $2 \text{ m/s}^2$
- E.13 (a) Seat top transmissibility of Seat E at  $0.5 \text{ m/s}^2$ ,  
(b)  $1 \text{ m/s}^2$ ,  
(c)  $1.5 \text{ m/s}^2$  and  
(d)  $2 \text{ m/s}^2$
- E.14 (a) Seatback in-plane transmissibility of Seat E at  $0.5 \text{ m/s}^2$ ,  
(b)  $1 \text{ m/s}^2$ ,  
(c)  $1.5 \text{ m/s}^2$  and  
(d)  $2 \text{ m/s}^2$
- E.15 (a) Seatback perpendicular transmissibility of Seat E at  $0.5 \text{ m/s}^2$ ,  
(b)  $1 \text{ m/s}^2$ ,  
(c)  $1.5 \text{ m/s}^2$  and  
(d)  $2 \text{ m/s}^2$
- E.16 (a) Seat top transmissibility of Seat F at  $0.5 \text{ m/s}^2$ ,  
(b)  $1 \text{ m/s}^2$ ,  
(c)  $1.5 \text{ m/s}^2$  and  
(d)  $2 \text{ m/s}^2$
- E.17 (a) Seatback in-plane transmissibility of Seat F at  $0.5 \text{ m/s}^2$ ,  
(b)  $1 \text{ m/s}^2$ ,  
(c)  $1.5 \text{ m/s}^2$  and  
(d)  $2 \text{ m/s}^2$
- E.18 (a) Seatback perpendicular transmissibility of Seat F at  $0.5 \text{ m/s}^2$ ,  
(b)  $1 \text{ m/s}^2$ ,  
(c)  $1.5 \text{ m/s}^2$  and  
(d)  $2 \text{ m/s}^2$

- E.19 (a) Seat top transmissibility of Seat G at  $0.5 \text{ m/s}^2$ ,  
(b)  $1 \text{ m/s}^2$ ,  
(c)  $1.5 \text{ m/s}^2$  and  
(d)  $2 \text{ m/s}^2$
- E.20 (a) Seatback in-plane transmissibility of Seat G at  $0.5 \text{ m/s}^2$ ,  
(b)  $1 \text{ m/s}^2$ ,  
(c)  $1.5 \text{ m/s}^2$  and  
(d)  $2 \text{ m/s}^2$
- E.21 (a) Seatback perpendicular transmissibility of Seat G at  $0.5 \text{ m/s}^2$ ,  
(b)  $1 \text{ m/s}^2$ ,  
(c)  $1.5 \text{ m/s}^2$  and  
(d)  $2 \text{ m/s}^2$

# List of tables

- 2.1 Improved automobile seat comfort survey [*Kolich, 1999*]
- 2.2 Determination of overall seat comfort indices [*Kolich, 1999*]
  
- 3.1 Actuator specification
- 3.2 SigLab and accelerometer specifications
- 3.3 Test seats
- 3.4 Test subjects
- 3.5 Consistent seat location for test subjects
- 3.6 SIP heights and seat top angles for test seats
  
- 4.1 Subjective procedure test results
  
- 5.1 A reduced version of Kolich's automobile seat comfort survey
  
- 6.1 Averaged dynamic seat comfort results
- 6.2 Overall dynamic comfort indices from the reduced Kolich survey
- 6.3 Subjective ride comfort ratings
- 6.4 SEAT values on the seat top
- 6.5 SEAT values on the in-plane seatback
- 6.6 SEAT values on the perpendicular seatback
- 6.7 Averaged r.m.s. vibration values measured on the test seats
- 6.8 Properties of the straight-line correlation between averaged subjective and objective dynamic seat comfort data
- 6.9 Correlation between calculated and estimated SEAT value
- 6.10 Comparison of measured and estimated SEAT value correlation with subjective dynamic seat comfort assessment
- 6.11 Comparison of traditional SEAT values and SEAT values assuming that the input vibration is a component in the direction of the output

- D.1 Acceleration r.m.s. values for Seat A
- D.2 Acceleration r.m.s. values for Seat B
- D.3 Acceleration r.m.s. values for Seat C
- D.4 Acceleration r.m.s. values for Seat D
- D.5 Acceleration r.m.s. values for Seat E
- D.6 Acceleration r.m.s. values for Seat F
- D.7 Acceleration r.m.s. values for Seat G

# Glossary

## **Symbols**

$\theta$	Angle between the floor-pan input and seat output vectors
$\alpha$	Angle between the plane of the seat top and the global vertical
$\omega$	Frequency vector in rad/s
$A$	Acceleration vector
$a$	Acceleration signal
$b$	Slope of the psychometric curve near the subjective level of equivalence
$c$	Constant
$f$	Frequency in Hz
$G$	Acceleration power spectrum
$H$	Measured vibration transmissibility
$n$	Trial number
$p_{50}$	Subjective level of equivalence or 50% threshold
$R^2$	Correlation coefficient
$t$	Time
$W_i$	Frequency weighting for the human response to vibration in the position and direction that it is of interest
$X$	Displacement vector

## **Nomenclature**

<b>Avg</b>	Average of a sample
<b>BS</b>	British Standard
<b>DC</b>	Direct current
<b>DSTF</b>	Dynamic seat testing facility
<b>FFT</b>	Fast-Fourier transform

<b>FRF</b>	Frequency response function
<b>ISO</b>	International Standardisation Organisation
<b>JND</b>	Just noticeable difference
<b>LVDT</b>	Linear variable differential transformer
<b>PSD</b>	Power spectral density
<b>r.m.s.</b>	Root mean square
<b>SEAT</b>	Seat effective amplitude transmissibility
<b>Stdev</b>	Standard deviation of a sample
<b>SIP</b>	Seat index point

## ***Subscripts***

<i>ff</i>	On the floor
<i>fs</i>	Between the floor and seat
<i>LB</i>	At the left-back of the seat track
<i>M</i>	Under the middle of the seat
<i>RF</i>	At the right-front of the seat track
<i>ss</i>	On the seat
x seatback	On the seatback in the perpendicular plane
z plat	On the platform in the vertical direction
z seatback	On the seatback in the vertical plane



# Introduction

Vehicle purchases are driven by consumer requirements such as functionality, safety, luxury, comfort and performance. The consumers' perspectives on the fulfillment of these requirements are often based on subjective perceptions. With the increasing sophistication of the automotive industry and tough competition, it is likely that vehicle manufacturers, who satisfy these requirements and create the perception of doing so, will sell the most cars.

Passenger seat comfort comprises of static and dynamic comfort. Static comfort refers to the comfort of the vehicle occupants when the vehicle is stationary such as when a client is seated in a vehicle on the showroom floor. The static comfort experience includes everything from the visual impression of the styling to the smell and tactile experience. A statically comfortable seat requires the minimum muscular effort from the occupant to maintain the seated position. This implies that muscular fatigue is minimized because the body is sufficiently supported by its contact with the seat, seatback and floor [Griffin, 1990, p. 388].

Dynamic comfort is mostly characterised by noise, vibration and harshness (NVH) when the vehicle is driven. The interior sound of the passenger's compartment has become increasingly important as automotive manufacturers strive to improve brand identity, customer loyalty, and perceived quality of their products [Govindswamy, 2004]. Noise and vibration are intricately linked as vibration can cause noise and vice versa.

Most of the vibration experienced by occupants in a vehicle is transmitted to the body through the seat. The vibration environment, the seat dynamic response and the response of the human body to vibration combine to determine the seat dynamic efficiency. The optimum seat is one that minimises unwanted vibration responses of the occupant in the relevant vibration environment [Griffin, 1990, p.389].

Dynamic comfort is usually assessed by making vibration measurements on the surface of car seats using methods based on ISO 2631:1997 and other national standards [Mansfield, 2001]. This is done using a seat-pad accelerometer that measures the vibration at the seat occupant interface. The question arises as to whether vibration measurements do in fact **assess occupant perception** of dynamic seat comfort.

Seat effective amplitude transmissibility (SEAT) value is a standard dynamic seat comfort metric that relates objective measurements and dynamic seat performance. It is defined as the ratio of the vibration on the seat and the vibration on the floor and accounts for human sensitivity to vibration. Van Niekerk et al. [2002] successfully correlated the subjective dynamic seat comfort experience of six subjects and 16 seats with SEAT values on the seat top for a single rough road stimulus.

The objective dynamic seat comfort assessment includes the calculation of SEAT values. These values can be calculated directly from vibration measurements on the seat top and floor or indirectly by estimating the vibration on the seat top from the seat transmissibility function. Low SEAT values indicate a good seat, whereas high SEAT values indicate a bad seat.

The goal of this project is to investigate the promising results of Van Niekerk et al. [2002] and to correlate the subjective dynamic seat comfort response with SEAT values for a different vertical road vibration input stimulus. Such a correlation would support a scientific method of predicting subjective dynamic seat comfort perceptions using SEAT values. This would provide vehicle



design teams with an effortless method to choose a seat that is dynamically the most comfortable for a specific application.

Subjective testing includes the application of a procedure referred to as “comparison of stimulus pairs” [Zwicker and Fastl, 1990, p.10]. This method eliminates the time lag between the comparison of two seats and human bias due to static comfort. Each trial in a paired comparison test consists of two vibration stimuli. During each trial the subject is asked to choose the more comfortable of the two stimuli. Through methods described in this text, the paired comparison test results in a subjective seat comfort rating. When the seat comfort ratings are combined they result in a subjective dynamic seat comfort assessment.

This document includes is report on all topics relevant to dynamic seat comfort assessment. Chapter 2 states the relevant standards, vibration measurement techniques and existing subjective and objective dynamic seat comfort assessment techniques obtained by a comprehensive literature survey. The experimental rig, the selection of subjects and seats, as well as the acquisition of data for test stimuli are summarised in Chapter 3. A more effective paired comparison testing procedure is discussed in Chapter 4. The choice of this procedure is further motivated by the discussion of an experimental comparison between five different paired comparison procedures. Chapter 5 explains and motivates the steps of a dynamic seat comfort assessment test. The experimental results are stated in Chapter 6, where the correlation between subjective dynamic seat comfort and SEAT values are discussed. Chapter 7 document concludes with a summary of important results and a recommendation of possible future areas of research.



# Literature survey

This chapter constitutes of a comprehensive summary of the literature that is relevant to dynamic seat comfort assessment. This necessitates the discussion of the relevant vibration measurement standards and experimental techniques. Subsequent paragraphs define seat effective amplitude transmissibility (SEAT) value as an objective metric for the assessment of objective dynamic seat comfort. The discussion continues by summarising subjective methods of dynamic seat comfort assessment, which include questionnaires and surveys as well as paired comparison procedures. The survey concludes with a summary of conclusions drawn by Van Niekerk in “The use of seat effective amplitude transmissibility (SEAT) values to predict dynamic seat comfort” [Van Niekerk et al., 2002].

## ***2.1 Vibration measurement standards***

### ***2.1.1 ISO 2631-1:1997 Mechanical vibration and shock – evaluation of human exposure to whole-body vibration***

ISO 2631 is concerned with whole-body vibration and excludes hazardous effects of vibration transmitted directly to the limbs. Vehicles, machinery and industrial activities expose people to periodic, random and transient mechanical vibration, which can interfere with comfort, activities and health.

The primary purpose of ISO 2631-1 is to define methods of quantifying whole-body vibration in relation to:

- Human health and comfort;
- The probability of vibration perception;
- The incidence of motion sickness.

The standard requires that vibration magnitudes should normally be expressed in  $\text{m/s}^2$  root-mean-square (r.m.s.), rather than in g, velocity, displacement or as peak or peak-to-peak values [Griffin, 1990, p.418]. This standard does not include vibration exposure limits, but contains methods for the evaluation of vibration containing occasional high peak values. Evaluation methods have been defined so that they may be used as the basis for vibration limits.

### **2.1.2 British standard guide to measurement and evaluation of human exposure to whole-body mechanical vibration BS 6841:1987**

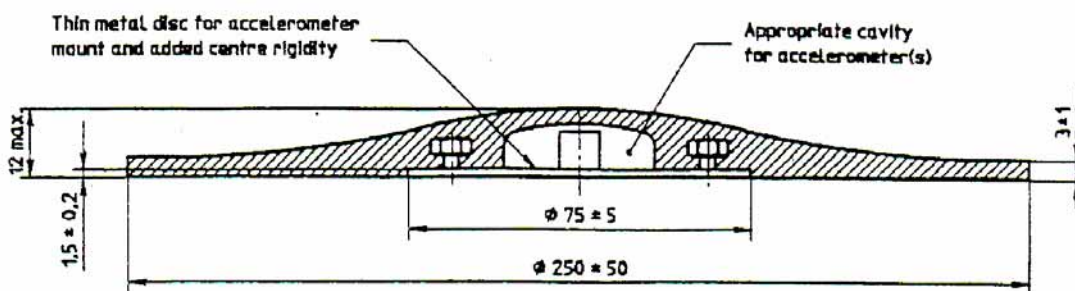
BS 6841 was prepared under the direction of the General Mechanical Engineering Standards Committee. This guide defines methods for quantifying vibration and repeated shocks in relation to human health, interference with activities, discomfort, the probability of vibration perception and the incidence of motion sickness. BS 6841 evolved from the fifth draft revision of the previous version of ISO 2631:1985 [Griffin, 1990, p.444].

The difference between BS 6841 provides for greater guidance on vibration effects without defining vibration limits, a method of assessing repeated shocks and intermittent vibration and modification and a more complete definition of necessary frequency weightings. BS 6841 also includes a standard means of assessing the discomfort caused by rotational vibration on the seat and translational vibration at the feet and seat back of seated persons. Griffin [1988] details the differences between ISO 2631:1985 and BS 6841 in an article, which falls beyond the scope of this dissertation. The difference in whole-body frequency weighting is briefly mentioned in Section 2.2.2.

### **2.1.3 ISO 10326-1:1992 mechanical vibration – laboratory method for evaluating vehicle seat vibration**

This standard specifies the basic requirements for the laboratory testing of vibration transmission through a vehicle seat to the occupant. These methods for measurement and analysis make it possible to compare test results from different laboratories.

The minimum level of equipment required is a vibrator capable of driving a platform in the vertical and/or horizontal directions. The dynamic response of the vibrator shall be capable of exciting the seat with the seated test person and additional equipment on it. For measurements on the backrest, accelerometers should be located in the vertical longitudinal plane through the centreline of the seat, with the measurement axis aligned parallel to the basicentric coordinate system.

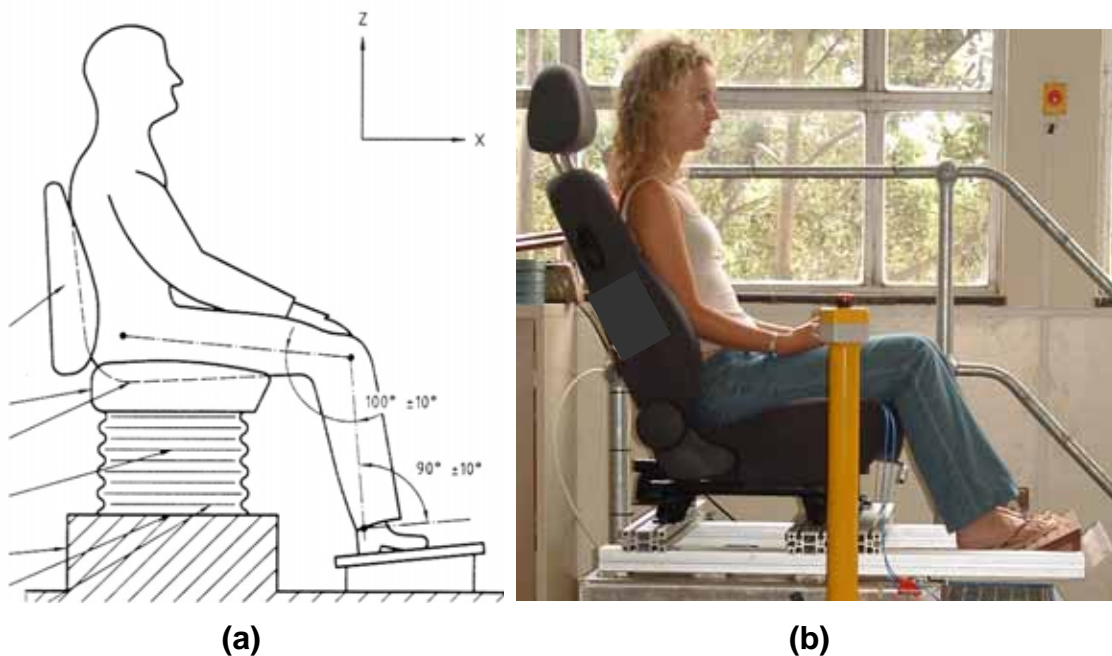


**Figure 2.1 A semi-rigid mounting disk used for seat pad accelerometers**

The standard specifies that the platform accelerometer should be centred directly below the seat accelerometer with the measuring directions parallel to the movement of the platform. Seat transducers shall be mounted in the centre of a mounting disk that is as thin as possible (Figure 2.1). The mounting disk is to be placed on the surface of the seat top and taped to the cushion. The position of the accelerometers are to be located midway between the ischial tuberosities of the seat occupant.

### **2.1.4 ISO 7096:2000 Earth-moving machinery – laboratory evaluation of operator seat vibration**

This International Standard specifies a laboratory method for measuring and evaluating the effectiveness of the seat suspension in reducing the vertical whole-body vibration transmitted to the operator of earth-moving machines at frequencies between 1 Hz and 20 Hz. The standard suggests the test person posture, given in Figure 2.2, and states that differences in posture of the test person can cause a 10% variance between test results. This is the reason for the recommended knee and ankle angles.



**Figure 2.2 (a) Suggested [ISO 7096, 2000] and (b) actual test person posture**

### **2.1.5 ISO 5353:1998 Earth-moving machinery, and tractor and machinery for agriculture and forestry – seat index point**

A method and device is specified for determining the position of the seat index point (SIP). This provides a uniform method for defining the location of the SIP in relation to a fixing point on the seat. The SIP may be determined on the seat by itself or when it is located in its operating environment.

The SIP is defined as the point on the central vertical plane of the seat as determined by the device shown in Figure 2.3, when installed in the seat as defined by ISO 5353:1998. From a practical point of view it is equivalent to the intersection on the central vertical plane through the seat centreline of the theoretical pivot axis between the human torso and thighs.



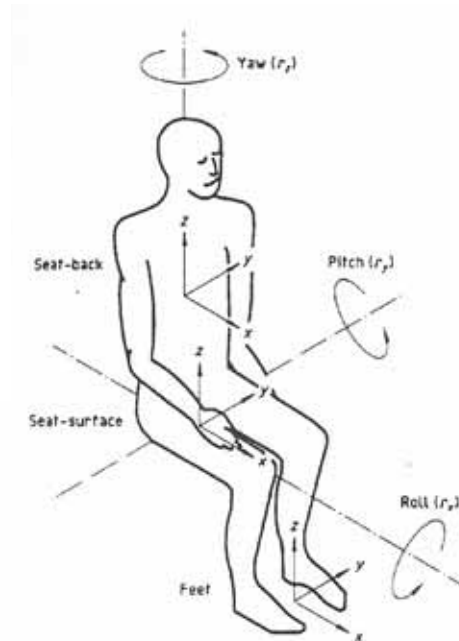
**Figure 2.3 A seat index point (SIP) gauge**

## ***2.2 Experimental techniques and measurement***

### ***2.2.1 Direction of measurement***

ISO 2631 stipulates that vibration shall be measured according to a coordinate system originating at a point from which vibration is considered to enter the human body. The principal relevant basicentric coordinate systems are shown in Figure 2.4.

If it is not feasible to obtain precise alignment of the vibration transducers with the preferred basicentric axis, transducers may deviate from the preferred axis by up to  $15^{\circ}$  where necessary. For a person seated in an inclined seat, the relevant orientation should be determined by the axis of the body and the z-axis will not necessarily be vertical. The orientation of the basicentric axis system to the gravitational field should be noted.

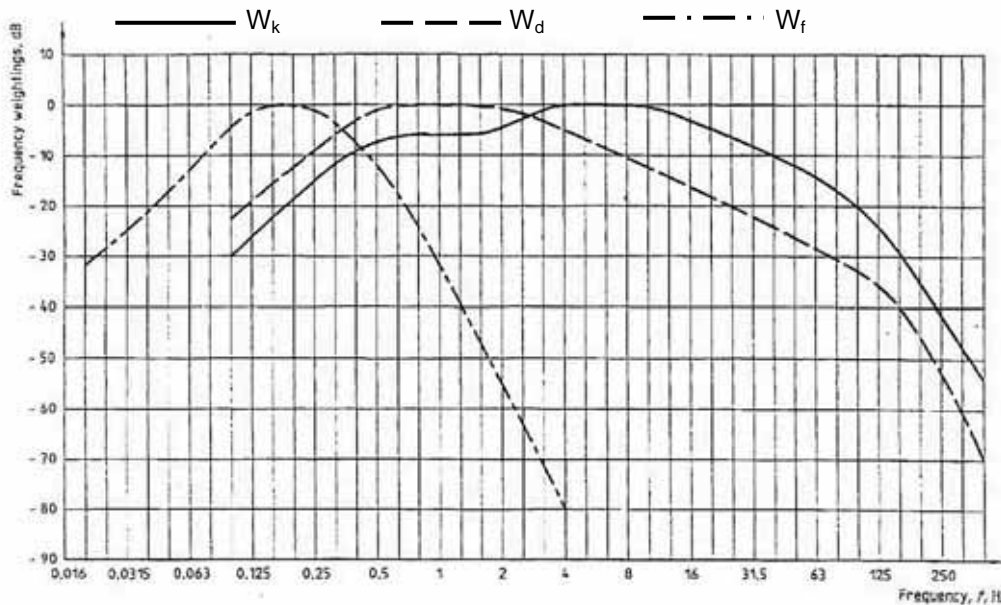


**Figure 2.4 The basicentric axis system for whole-body vibration measurement of a seated person [ISO 2631:1, 1997]**

## **2.2.2 Frequency weighting**

The human body reacts to different vibrations in different ways. Its sensitivity depends on vibration frequencies. In the case of whole-body vibration, different frequency weightings are used, depending on the direction of vibration transmission to the body, points of transmission and body position.

Weighting functions are specified in ISO 2631:1997 and adopted in the filters used for the exposure evaluations of this study ( $W_k$ ,  $W_d$  and  $W_f$  shown in Figure 2.5). These filters are based on the assumption that the frequency dependence of human sensitivity was the same for all effects of vibration on the body [Griffin, 1990, p.418]. For vibration comfort and perception of seated persons,  $W_k$  is used for seat surface vibration in the z-direction,  $W_d$  for the seatback z-axis and  $W_c$  for the seatback x-axis. BS 6841:1987 uses  $W_b$  when calculating the effects of vertical vibration on health and comfort.  $W_b$  differs from  $W_k$  (used by ISO 2631:1997) in that it affords less weighting to vibrations between 0.5 and 2 Hz and more importance to vibrations with frequencies above 8 Hz [Griffin, 1990, p.447].



**Figure 2.5 Frequency weighting for principle weightings [ISO 2631:1, 1997]**

### **2.2.3 Seat-pad positioning**

Transducers placed at the seat-occupant interface should not compress the seat (therefore altering the seat dynamic properties) or alter occupant posture [Griffin, 1990, p.393]. Localised measures of vibration show that vibration on the surface of a car seat is a function of measurement location [Mansfield, 2001].

Seat-occupant vibration shows the greatest vibration magnitude behind the knee, decreasing toward the centre of the seat and reaching a minimum at the seat midpoint behind the thigh. Vibration magnitude slightly increases again toward the back of the seat. This trend is consistent for all subjects measured [Mansfield, 2001]. These facts indicate that standardised seat vibration measurement does not record the maximum vibration on the seat, but rather the most conservative vibration levels.

One might speculate that comfort is related to the total vibration exposure on the seat surface integrated across a two-dimensional area. Another approach might suggest that comfort is related to the 'worst' zone on the seat. However, the variation of vertical seat vibration across the seat surface is smaller than the variation in vibration measured on the seat surface for different seated subjects [Griffin, 1990].



The most repeatable measurements are taken underneath the ischial tuberosities of the seated subject, with the seat pad accelerometer fixed to a specific location on the seat (not allowing for self-positioning). The seat top accelerometer should be mounted 128 mm from the seat back cushion, bulge side up. The seatback accelerometer pad should be centred 320 mm above the seat top, with the bulge towards the seat [Greenberg et al., 1998]. For vertical input vibrations, seatback measurements are recorded in the x- and z-directions of the basicentric axis system.

## **2.3 Seat transmissibility**

Transmissibility is defined as the non-dimensional ratio of the response amplitude of a system in steady-state forced vibration to the excitation amplitude expressed as a function of the vibration frequency. The ratio may be one of forces, displacements, velocities or accelerations [Griffin, 1990, p.586].

The most direct method of measuring the transmissibility of a seat is to compare the acceleration on the seat (seat-occupant interface) with that, at the base of the seat [Griffin, 1990, p.391]. The transmissibility can be measured in any axis (vertical or horizontal) or to any point (beneath the ischial tuberosities or between the human back and backrest). Most published studies investigate the vertical transmissibility from the seat base to the ischial tuberosities.

### **2.3.1 Transmissibility measurements in the laboratory**

Vibration testing of automotive seats can be carried by a variety of different procedures. Vibration can be measured inside the vehicle, but this requires the seat to be fixed and for the vehicle to be driven over the required surfaces. Factors such as speed, varying terrain and the evaluation of different subjects reduce test repeatability. The entire procedure would have to be repeated for each seat to be assessed [Van Niekerk, 2002].

Another measurement approach requires separate measurement of the vehicle floor vibration and the vibration characteristics of the seat. Laboratory measurements eliminate the need to measure seat vibration response in vehicles. An additional advantage is that the input vibration spectrum can be controlled. This makes it possible to determine the seat transmissibility at all frequencies and not merely at the dominant frequencies in the vehicle vibration input spectrum. It is possible to measure the transmissibility in each axis without concern that motion in one axis on the seat is caused by motion in another axis at the seat base.

Comparisons between measurements of transmissibility in the field and in the laboratory have shown that similar values can be obtained [Griffin, 1990, p.394]. The use of volunteer human subjects must involve considerations of their suitability for the purpose of the study and the safety of the apparatus.

A comparison of seat transmissibility for different seats with different cushions for the same subject and the same vibration conditions has shown significant variation in vibration on the seat. These differences are large enough to influence human responses to vibration in any environment where there is significant vertical vibration at frequencies above about 1.5 Hz. Pielemeier et al. [1999] identifies the critical factors of transmissibility comparison as using the same human subjects for comparing seats, consistent seat position and critical seat accelerometer positioning.

### **2.3.2 Seat testing with masses and dummies**

A study by Smith [1997] on the limitations of manikins to reproduce human vibration characteristics has shown that neither manikins nor rigid bodies of similar weight were effective in predicting the primary human resonance effects in the 4 – 8 Hz frequency range. The seat-occupant system displays a vertical resonance frequency of around 4 Hz. Tests with a rigid mass might sometimes indicate a similar resonance frequency, but the amplification at resonance and attenuation at high frequencies will be overestimated [Griffin, 1990, p.396].

The use of dummy systems presents challenges such as restraining the dummy in the correct position in the seat and maintaining system calibration. Dummies remain an unattractive means of determining seat transmissibility, as their non-linearities are currently unsuccessful in reproducing the non-linear responses of the human body. The relevant transmissibility required is for the seat-person combination.

### **2.3.3 Non-linearity**

Non-linear systems are defined as “those in which any of the variable forces are not directly proportional to the displacement, or its derivatives with respect to time” [Griffin, p.833]. As the responses of the seat-occupant system have significant non-linearity, seat transmissibility will not be the same if the spectrum of vibration used in the laboratory differs greatly from that in the field. The variation of seat transmissibility with different magnitudes of vibration stimuli must be taken into account when dynamic seat comfort is considered [Griffin, 1990, p.398].

Pielemeier et al. [1999] suggests measuring seat transmissibility at three vibration levels (low, mid, high) for each subject in order to take non-linearity into account. Seat-occupant transmissibility values display similar resonance frequencies despite the use of subjects with vastly different weights [Van Niekerk, 2002].

## **2.4 Seat effective amplitude transmissibility (SEAT) values**

### **2.4.1 Definition of SEAT value**

**Seat effective amplitude transmissibility (SEAT) value** is a standardised metric for relating **objective measurements** and **subjective evaluation of dynamic seat performance**. SEAT values are computed by:

$$SEAT\% = \left[ \frac{\text{Vibration on the seat}}{\text{Vibration on the floor}} \right] \times 100 \quad (2.1)$$

Vibration evaluations are based on r.m.s. measures for stimuli that have low crest factors [Griffin, 1990, p.445]. For these vibrations the SEAT value relation can be rewritten as:

$$SEAT\% = \left[ \frac{\int G_{ss}(f)W_i^2(f)df}{\int G_{ff}(f)W_i^2(f)df} \right]^{\frac{1}{2}} \times 100 \quad (2.2)$$

Where  $G_{ss}(f)$  and  $G_{ff}(f)$  are the seat and floor acceleration power spectra and  $W_i(f)$  is the frequency weighting for the human response to the vibration of interest [Griffin, 1990, p.405]. For seat-floor vibration measurements, the weighting functions will be used for the **vibration on the seat**.

A SEAT value of 100% indicates that, although the seat may have amplified the low frequencies and attenuated the high frequencies, there is no overall improvement or degradation in vibration discomfort produced on the seat. A SEAT value of 100% therefore means that an occupant sitting on the floor would experience similar discomfort. The degree to which the SEAT value is less than 100% indicates the amount of useful isolation provided by the seat. A value greater than 100% indicates that the seat increases the level of discomfort [Mansfield, 2001]. Low SEAT values have been proven to correlate with good subjective ride comfort assessments, whereas higher values indicate a bad seat for the excitation scenario [Van Niekerk, 2002].

The Vibration on the floor (Equation 2.1) values involve acceleration measurements made at the seat track. Vibration on the seat can be measured on the seat cushions for various subjects or computed by using the seat transfer function [Pielemeier et al., 1999 and Paddan, 1999]. The latter procedure is convenient as the SEAT value can be calculated for various different excitations without re-measuring the seat vibration (assuming negligible non-linear

behaviour from the seat). Consequently the relation for SEAT value calculation becomes:

$$SEAT\% = \left[ \frac{\int G_{ff}(f) |H_{fs}(f)|^2 W_i^2(f) df}{\int G_{ff}(f) W_i^2(f) df} \right]^{\frac{1}{2}} \times 100 \quad (2.3)$$

Where  $H_{fs}(f)$  is the known or measured transfer function between the seat and floor vibration. In 2002, a study by Van Niekerk et al. reported a good correlation ( $R^2 = 0.94$ ) between measured and estimated SEAT values by averaging the SEAT values of six carefully selected subjects.

SEAT value implies that vibration isolation on the seat depends on the vibration input spectrum, seat transfer function and relative sensitivity of the body at different vibration frequencies. The greatest attenuation of occupant discomfort occurs at the frequencies where there is maximum floor vibration and the body is most sensitive. This implies that it is not possible to judge the suitability of a seat by sole consideration of its damping, stiffness or transmissibility [Van Niekerk et al., 2002].

#### **2.4.2 Cross-axis transmissibility in computing SEAT value**

Two interpretations have arisen upon deciding on how to compute SEAT values for computations of input and output which are not in the same direction (as with the vibration caused on the seat backrest by vertical vibration input at the base of the seat).

The first approach assumes the presence of a cross-transmissibility in the seat, which causes the vibrations in one direction to be converted to vibrations in another direction. A second approach states that the vibrations in the output direction are simply the component of the input vibration that is in the input direction, modified by system mechanical properties along that component

direction. Research conducted by Van Niekerk et al. [2002] and a closer look at the definition of SEAT value support the second interpretation.

If it were assumed that the output vibration is based on the component of the input vibration that is in the direction of the output, there would be no appreciable output in all input/output cases that are truly perpendicular. Where the output is not truly perpendicular to the input, the output magnitude should tend to scale by the cosine of the angle between the output and input. This is supported by data gathered by Van Niekerk et al. [2002] for seat backs angled at 24° to the vertical. Data showed that the vertical track-in, vertical seatback-out transmissibility (where the angle was 24°) displayed low frequency gains around cosine 24°= 0.9. Where the angle was 90 – 24 = 66°, as is the case with the vertical track-in, longitudinal back-out, low frequency gain magnitudes matched cosine 66° = 0.4.

The Handbook of Human Vibration states that “a SEAT value of 100% means that sitting on the floor (or on a rigid seat) would produce similar vibration discomfort,” and defines SEAT value as “the ratio of the frequency-weighted and time-averaged vibration measured on the seat to the vibration on the same axis on the floor conditioned by the same weightings and time averaging” [Griffin, 1990, p.405]. It is concluded that the SEAT value of an angled seatback should be treated as follows: the input vibration in the denominator must be scaled by the cosine of the angle between the input and the output measurement. The human weighting curve should be the one relevant to the output direction and applied to the input and output vibration. The SEAT value computation thus becomes

$$SEAT\% = \left[ \frac{\int G_{ff}(f) |H_{fs}(f)|^2 W_i^2(f) df}{\int G_{ff}(f) \cos^2(\theta_{fs}) W_i^2(f) df} \right]^{\frac{1}{2}} \times 100 \quad (2.4)$$

Where  $\theta_{fs}$  is the angle between the floor pan input and seat output vectors. The cosine factor in the denominator collapses to the existing formulation of SEAT

value for the parallel input-output case as the angle is zero and the cosine  $0 = 1$ . The relation also satisfies the formulation that one would arrive at a 100% SEAT value for a rigid seat, because the cosine in the transmissibility function of the numerator would be the same as the cosine in the denominator, resulting in a ratio of 1 [Van Niekerk *et al.*, 2002].

## **2.5 Subjective dynamic seat comfort assessment**

Literature on subjective dynamic seat comfort assessment strategies is discussed in two groups. The first approach involves questionnaires and surveys and the second, paired comparison tests.

The discussion of questionnaires and surveys includes the subjective differential method of Kolrep [2001], Kolich's improved seat comfort survey [1999] and methods of predicting passenger discomfort [Parsons and Griffin, 1983]. Kazushige's [1998] paired comparison study is briefly summarised, followed by a detailed discussion of the psychometric method of constants [Greenberg *et al.*, 1999], which was used extensively in the methodology of this project.

### **2.5.1 Questionnaires & surveys**

#### **2.5.1.1. Subjective differential method**

Some subjective assessment strategies include setting up questionnaires. Kolrep [2001] validated a questionnaire, which used adjective contrasts for subjective assessment that would differentiate cars and road conditions. Parameters were identified by the simultaneous measurement of objective and subjective data during ride sessions.

The concepts of comfort are independent entities associated with different factors; comfort is related to well-being and aesthetics, whereas discomfort has involves biomechanics and fatigue. Due to these factors Kolrep claims that a

multidimensional method like the semantic differential method seems appropriate to assess comfort impairment.

The subsequent development of a subjective ride comfort questionnaire satisfies distribution and reliability criteria and comprises of 12 pairs of adjectives. The final questionnaire adjective pairs are:

- Good-natured – Unruly
- Steady – Unsteady
- Stable – Unstable
- Controlled – Uncontrolled
- Pleasant – Unpleasant
- Sporty – Comfortable
- Tight – Slack
- Solid – Hollow
- Sharp – Blurred
- Direct – Indirect
- Spartan – Luxurious
- Cheap – Stylish

A high objective-subjective correlation was achieved by using this questionnaire for cowl shake in convertible cars.

#### ***2.5.1.2 Kolich's improved seat comfort survey***

Kolich's survey [1999] was designed by creating a preliminary survey with careful consideration and special attention to the principles of good survey design and analysis. A few overall measures were defined to serve as comfort indices. The survey was evaluated for test-retest reliability by measuring seat comfort on the same individuals at two points in time (five months apart).

High reliability of survey criteria is indicated by a high correlation coefficient (statistically significant correlation). The preliminary survey was shortened through this process, leaving 10 survey items with statistically significant test-retest reliability. The decision criterion was 0.05.



**Table 2.1 Improved automobile seat comfort survey [Kolic, 1999]**

<i>Item</i>		-3	-2	-1	<i>Just right</i>	1	2	3	
<b>Seatback</b>									
A. Amount of lumbar support	too little	<input type="checkbox"/>	<input type="checkbox"/>	<input type="checkbox"/>	<input type="checkbox"/>	<input type="checkbox"/>	<input type="checkbox"/>	<input type="checkbox"/>	too much
B. Lumbar comfort	uncomfortable	<input type="checkbox"/>	<input type="checkbox"/>	<input type="checkbox"/>	<input type="checkbox"/>	<input type="checkbox"/>	<input type="checkbox"/>	<input type="checkbox"/>	
C. Amount of mid-back support	too little	<input type="checkbox"/>	<input type="checkbox"/>	<input type="checkbox"/>	<input type="checkbox"/>	<input type="checkbox"/>	<input type="checkbox"/>	<input type="checkbox"/>	too much
D. Mid-back comfort	uncomfortable	<input type="checkbox"/>	<input type="checkbox"/>	<input type="checkbox"/>	<input type="checkbox"/>	<input type="checkbox"/>	<input type="checkbox"/>	<input type="checkbox"/>	
E. Amount of back lateral support	too little	<input type="checkbox"/>	<input type="checkbox"/>	<input type="checkbox"/>	<input type="checkbox"/>	<input type="checkbox"/>	<input type="checkbox"/>	<input type="checkbox"/>	too much
F. Back lateral comfort	uncomfortable	<input type="checkbox"/>	<input type="checkbox"/>	<input type="checkbox"/>	<input type="checkbox"/>	<input type="checkbox"/>	<input type="checkbox"/>	<input type="checkbox"/>	
G. Seatback feel/firmness	too soft	<input type="checkbox"/>	<input type="checkbox"/>	<input type="checkbox"/>	<input type="checkbox"/>	<input type="checkbox"/>	<input type="checkbox"/>	<input type="checkbox"/>	too firm
<b>Cushion</b>									
H. Ischial/buttocks comfort	uncomfortable	<input type="checkbox"/>	<input type="checkbox"/>	<input type="checkbox"/>	<input type="checkbox"/>	<input type="checkbox"/>	<input type="checkbox"/>	<input type="checkbox"/>	
I. Thigh comfort	uncomfortable	<input type="checkbox"/>	<input type="checkbox"/>	<input type="checkbox"/>	<input type="checkbox"/>	<input type="checkbox"/>	<input type="checkbox"/>	<input type="checkbox"/>	
J. Cushion lateral comfort	uncomfortable	<input type="checkbox"/>	<input type="checkbox"/>	<input type="checkbox"/>	<input type="checkbox"/>	<input type="checkbox"/>	<input type="checkbox"/>	<input type="checkbox"/>	

**Table 2.2 Determination of overall seat comfort indices [Kolic, 1999]**

<i>Item</i>	<i>Subject #1</i>	<i>Subject #2</i>	<i>Subject #3</i>
A	1	0	1
B	-1	-1	-1
C	-1	0	0
D	-1	0	0
E	-1	0	0
F	-1	0	0
G	1	0	0
H	-1	0	0
I	-1	0	0
J	0	0	0
<b>Overall comfort index</b>	<b>9</b>	<b>1</b>	<b>2</b>

The overall seat comfort index is determined by summarising subjective data. The absolute values of the differences between survey items and the just-right level are summed to obtain the overall comfort index (Table 2.2). A comfort index of zero indicates the most comfortable seat.

### **2.5.1.3 Methods of predicting passenger vibration discomfort [Parsons and Griffin, 1983]**

Parsons and Griffin [1983] defined some variables affecting passenger vibration discomfort by summarising the laboratory experiments of a number of authors. These variables included the vibration axis, vibration frequency, vibration level, multiple-frequency vibration, random vibration, vibration duration, impulsive vibration, multiple-axis vibration, input point to the body and subject posture.

This study proposes that the aforementioned factors should be included in a procedure for predicting passenger vibration discomfort.

A wide range of vibration conditions was obtained by driving six road vehicles over twelve different road sections for eight subjects. The car was driven at the same speed in a single gear for each road section. A range of vehicle speeds and gears were used over the twelve road sections. Vibration measurements were made in the z-direction at the subjects' feet.

Subjective vibration discomfort was rated on a 100 mm line, which had ends that were labelled "little discomfort" and "much discomfort". The vehicles were driven in the same direction around a circuit, which contained all 12 road sections. Each road section was indicated to the driver by the experimenter (seated on the back seat), who gave the commands "ready", "go" and "stop" at the appropriate times. Immediately after the command "stop", the subject rated the degree of vibration discomfort between the commands, "stop" and "go" (approximately 20 s).

The subjective ratings were quantified by measuring the distance between the left end of the scale (labelled "little discomfort") and the point where the subject made his mark on the 100 mm line (Figure 2.6). Thus, the higher the rating, the more uncomfortable the subject found the vibration.



**Figure 2.6 Subjective dynamic comfort rating on a 100 mm line [Parsons and Griffin, 1983]**

### **2.5.2. Paired comparison tests**

Paired comparison procedures are used if the effects of variations along different dimensions are to be evaluated. Each paired comparison trial consists

of two stimuli in which the subject has to decide on the one that he perceives to be preferred for the dimension in question. As a rule, the sensitivity of a subject is enhanced if a comparison among several alternatives is possible [Zwicker and Fastl, 1990, p.10].

### **2.5.2.1. Models of overall seat discomfort [Kazushige, 1998]**

#### *2.5.2.1.1 Method*

Subjects were subjected to 15 seconds of one-third octave narrow-band vibration at magnitudes of 0.25 m/s<sup>2</sup> and 0.5 m/s<sup>2</sup> r.m.s., excited on a shaker platform. Subjects sat on a pair of seats on the shaker platform and were exposed to vibrations in order to obtain the relative overall seat discomfort. Each combination was tested twice in different sitting order to take the order effect into account. The subjects were asked to respond to the question:

“Please judge the relative overall discomfort of the samples using the following scale.”

The subjects were required to assess the relative overall discomfort of the samples for each sitting in terms of the following scale:

- +3: 1<sup>st</sup> VERY MUCH MORE DISCOMFORT than 2<sup>nd</sup>
- +2: 1<sup>st</sup> DEFINITELY MORE DISCOMFORT than 2<sup>nd</sup>
- +1: 1<sup>st</sup> SLIGHTLY MORE DISCOMFORT than 2<sup>nd</sup>
- 0: 1<sup>st</sup> THE SAME DISCOMFORT than 2<sup>nd</sup>
- 1: 1<sup>st</sup> SLIGHTLY LESS DISCOMFORT than 2<sup>nd</sup>
- 2: 1<sup>st</sup> DEFINITELY LESS DISCOMFORT than 2<sup>nd</sup>
- 3: 1<sup>st</sup> VERY MUCH LESS DISCOMFORT than 2<sup>nd</sup>

According to this method, the first seat sample is characterised in relation to the second seat, which serves as a reference.

#### *2.5.2.1.2 Analysis*

##### *2.5.2.1.2.1 Relative overall discomfort score*

The scores for overall discomfort are obtained from the paired comparison tests. The average scale for the popularity is regarded as the relative overall

discomfort score and is obtained from an equation stated in an article by Muira [1973]. Differences in the relative overall discomfort scores between samples that correspond to statistically significant levels are obtained by calculating the yardstick. This method is used to determine both static and dynamic comfort of seats the resultant relative overall discomfort scores evaluate the seats relative to each other. Selection of the most comfortable seat is therefore possible.

A good seat will have good static and dynamic characteristics. Paired comparison tests are carried out independently at different vibration magnitudes. This implies that the overall discomfort scores at different vibration magnitudes cannot be compared directly as the human sensitivity to increased vibration varies with vibration magnitude.

A comparison of overall discomfort scores at different vibration magnitudes is made possible by dividing the scores by the value of the corresponding 5% yardstick at the vibration magnitude. The relative overall discomfort values are then considered as transformed into the same scale and assumed to be comparable. Unit scale corresponds to the 5% significant difference level: if the distance between samples is greater than unity, there is a statistically significant difference in relative overall seat discomfort between the samples at the 5% difference level.

### ***2.5.2.2 Subjective dynamic seat comfort assessment with the psychometric method of constants [Greenberg et al., 1999]***

#### *2.5.2.2.1 Method*

##### *2.5.2.2.1.1 Virtual seat simulation*

The virtual seat method is a paired comparison test in which each trial consists of two stimuli: a *virtual reference stimulus* and an *alternative stimulus*.

The rig used for this method is a man-rated shaker with a platform that provides for the mounting of test seats and seated human subjects. The shaker is used

to generate a *reference vibration* that is the **same on the seat cushion** for every seat and every subject. This vibration is used as a *reference standard*.

Seat test vibration stimuli (referred to in this text as *alternative stimuli*) are consequently applied at the **seat track**, allowing the seat properties to filter the vibration. The *reference* and *alternative vibrations* are evaluated against each other in back-to-back comparisons and evaluated through their relationships with the *reference*.

Advantages of the virtual seat simulation approach are that the time delay between test runs is omitted because the stimuli are immediately played back-to-back. Human bias and the effect of static comfort are overcome as the respondent experiences both vibrations on the same seat. The static comfort for different test runs is therefore identical. The *reference stimulus* is similar to the comparison test vibrations played at the seat track, so that it is reasonable to compare them.

#### 2.5.2.2.1.2 Stimulus used to obtain subjective data

The stimulus for use during virtual seat simulation was the vertical vibration measured in a vehicle, driven on a moderately rough road. This stimulus was the basis for both the *virtual reference stimulus*, which was identical at the seat cushion, and the *scaled level alternatives*, which were identical at the seat track.

The *alternative stimuli* included a number of scaled copies of the road vibration recording. They were the same at the seat track for each subject and each seat.

The *virtual reference stimulus* was generated by playing an intermediate level version of the *scaled alternatives* on a randomly chosen seat, with a randomly chosen subject and then measuring the resulting vibration at the seat cushion. The *virtual reference* was then reproduced at the cushion of each seat for each subject, using the virtual seat method.

The *virtual reference stimulus* was paired with the series of *scaled alternatives*. In each trial, subjects were asked to indicate whether the *reference* or the current *scaled alternative*, was more comfortable for each pair.

#### 2.5.2.2.1.3 Generation of the reference vibration [Greenberg et al., 1999]

*Step 1:* Vertical acceleration data is measured at the seat track of a vehicle, driven over a test track with a surface referred to as a rough road. The purpose of this is to obtain a realistic rough road vibration sample for use in subjectively evaluating the ability of various seats to mitigate rough road vibrations.

*Step 2:* The data taken at the seat track is band-limited to a frequency range of 0.5 to 40 Hz. The result is labelled '*Alternative A*' for testing.

*Step 3:* *Alternative A* is successively scaled down in intensity by a repeated factor 0.75 to produce *alternatives B, C, D, E, F and G*. The factor 0.75 produces samples that differ in intensity by three times the minimum difference detectable by a sensitive subject (referred to as 3 JNDs) [Pielemeier et al., 1997]. These seven signals provided the *alternatives* played through the test seat for evaluation. *Alternative C* was chosen to provide the basis for the *reference vibration*.

*Step 4:* The chosen *alternative* for generating the *reference vibration* is reproduced at the seat track of the shaker. An arbitrary seat is selected from the seat samples.

*Step 5:* The resulting seat vibration at the seat top (with an arbitrarily chosen subject) is recorded with a seat pad accelerometer. The purpose is to measure a realistic seat top vibration that might correspond to one of the seat track *alternative vibrations*. This vibration signal is known as the *reference vibration* and used on every test seat in the testing phase.

Subjectively better seats would improve the comfort of all the scaled *alternative stimuli*. A more severe version, at the seat track, would therefore match with the seat *reference*.

Poorer seats would reduce the comfort of all the scaled *alternative stimuli* causing a milder version of the (at the seat track), to match with the virtual *reference* (at the seat cushion). The paired comparison procedure typically involved five to seven levels of scaled *alternative stimuli*.

#### 2.5.2.2.1.4 Subjective rating scale

A Just Noticeable Difference (JND) scale was used as the subjective rating scale. This scale refers to the smallest change in whole body vibration that a typical subject can detect. One JND roughly represents a 10% increase in the level of vibration. Alternative seat track stimuli were scaled to be 3 JNDs apart in magnitude, requiring 33% increases between them ( $1.1^3 = 1.33$ ).

#### 2.5.2.2.2 Analysis

The two-interval, forced-choice process is analysed as follows: The selection operation by the subject is modelled as a noisy process where the subject has a certain probability of choosing the *reference* against each *alternative*, depending on how far they are apart in comfort. The sequence of trials in which the subject is forced to choose the *reference* or the *alternative* in each trial with these underlying probabilities, is called a set of Bernoulli trials. A set of trials at one *alternative* level gives an estimate of the underlying probabilities. The probability of choosing the *reference*  $x$  out of  $n$  trials is given by a binomial distribution. The accuracy of the estimate depends on the number of trials and the underlying probability. The binomial distribution allows confidence intervals to be estimated given that information.

The plot of resulting probabilities and confidence intervals, as a function of JND level of the *alternatives*, is a psychometric function.

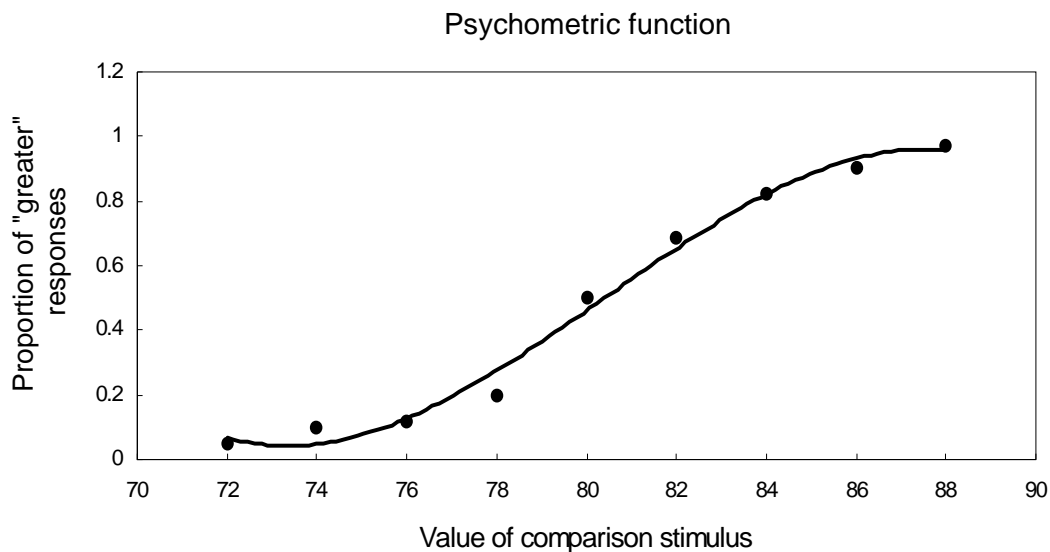
##### 2.5.2.2.2.1 Psychometric functions [Greenberg *et al.*, 1999]

\*Note that “g” in Section 2.5.2.2.2.1 refers to **grams** and not acceleration ( $g=9.81 \text{ m/s}^2$ )

A typical psychometric function is plotted in Figure 2.7. Imagine a test subject is first given a small weight and asked to lift it in his hand. In this example, the first weight is always of the same mass, for example 100 g. The subject is subsequently asked to set this weight down and is given a second weight of identical size and shape, but differing in mass. The subject is forced to judge which weight felt heavier: the first or second? The psychometric function is plotted by placing mass (in grams) on the ordinate and the proportion of time

that the subject judged the second weight to be heavier than the first, on the abscissa.

At 80.6 g, the probability of choosing the second weight as heavier is only 50%. In this case, the subject is simply guessing and we judge that the two stimuli are of equal magnitude. At 83.3 g, the probability of choosing the second weight as heavier rises to 75%. This point, halfway between certainty (100%) and guessing (50%) is called the upper difference level. The change in stimulus required to reach this point is a JND.



**Figure 2.7 Psychometric function for difference threshold determination**  
**[Greenberg et al., 1999]**

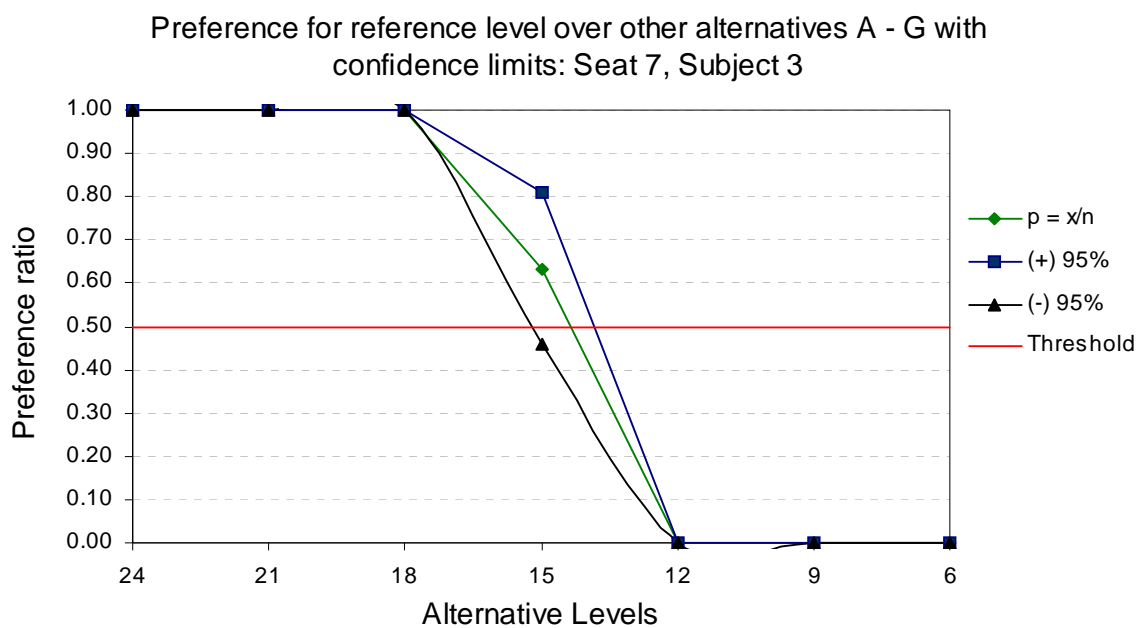
When this approach is applied to seat comfort, subjective judgement of seat vibrations is compared instead of subjective judgement of weights.

#### 2.5.2.2.2 Psychometric functions for determining seat ride comfort

The point on the psychometric function at which the probability of choosing the virtual *reference* versus the *alternative* is 50:50, is the point at which they match in the subject's perception. That JND level is assigned to the seat as the subjective rating. This implies that higher JND levels are better, as they indicate that the seat attenuated the vibration of a higher-level input *alternative* at the seat track enough to match the *reference*.



An arbitrary zero point is chosen for the JND scale, and numbers are assigned to *alternatives A* to *G*, 3 JND's apart. Twenty to 30 trials were run close to the threshold (where the probability ratio is 50%) to increase the resolution at which the subjective point of equivalence (the 50% threshold) is determined. Further from the threshold, where the preference ratio approaches 0 or 1 and the standard deviation reaches zero. In this case the number of trials does not have to be so large to make the standard deviation small, and ten trials were considered to be enough. The use of a few trials far from the threshold makes the estimates of confidence limits by Gaussian distribution values unrealistic at the extremes. The important region for the estimation of confidence limits is considered to be close to the threshold, where the approximation of a 30-trial binomial distribution by a Gaussian is considered reasonable.



**Figure 2.8 Psychometric plot for a typical case [Greenberg et al., 1999]**

The threshold is determined by finding the JND value where the lines connecting the preference ratio values cross a preference ratio of 0.5. This is done through linear interpolation. At this point, the *reference* and *alternative stimuli* are equally preferred, and therefore subjectively equivalent. The number on the JND scale is taken as the subjective rating (the JND level is 14.4 on the example in Figure 2.8). The threshold values are determined for the 95% confidence limit values. This implies that there is a 95% chance that the

subjective rating will lie between 13.9 and 15.2 JNDs, for this example. Therefore the confidence interval is  $15.2 - 13.9 = 1.3$  JND' s.

#### 2.5.2.2.3 Advantages

Data generally covers a wide range of stimulus levels. This means that it is possible to test the validity of parametric assumptions [Levitt, 1970]. Stimulus levels and sequences can be prepared in advance of the experiment, improving the overall flow of experimentation. The pooled acquisition of data gives the subject a chance to “practice” their response, therefore improving test validity.

#### 2.5.2.3 Levitt procedures [Levitt, 1970]

The Levitt procedure is an adaptive paired comparison procedure, where the level of the *alternative stimuli* in each paired comparison trial is determined by the subject's response in preceding trials. This method promises significant advantages over the psychometric method of constants and is discussed in greater detail in Chapter 4.

### 2.6 The use of seat effective amplitude transmissibility values to predict dynamic seat comfort [Van Niekerk et al., 2002]

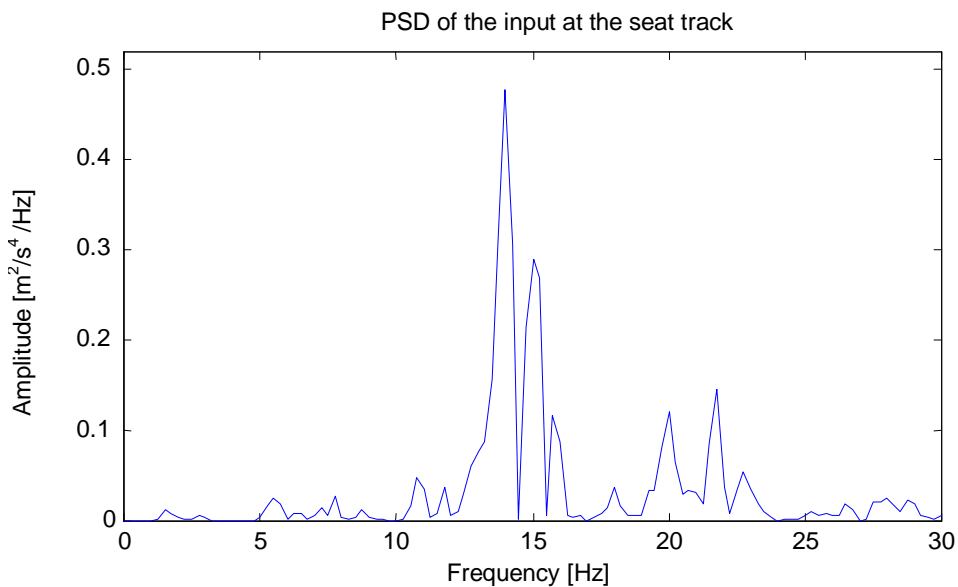
Van Niekerk et al. [2002] applied the virtual seat simulation method and the psychometric method of constants (as discussed in Section 2.5.2.2) to gather a subjective dynamic seat comfort assessment.

The *alternative stimuli* were created from scaled versions of a direct vibration measurement at the seat track of a vehicle driven on a rough road. The *reference stimulus* was produced from a scaled version of this measurement and had an r.m.s. magnitude of about  $1.6 \text{ m/s}^2$ . The majority of the vibration energy of the test stimuli was concentrated between 12 – 17 Hz (Figure 2.9).

SEAT values were calculated from measurements on the seat when the road vibration measurement was played at the seat track. An additional set of SEAT

values were estimated by approximating the vibration on the seat top from seat track vibrations by using the seat transmissibility.

Van Niekerk et al. [2002] concluded that the correlation between individual subjective and objective dynamic seat comfort assessments range from good to poor ( $R^2 = 0.31$  to  $R^2 = 0.77$ ). The correlation between averaged, estimated SEAT values on the seat top and averaged, subjective ratings was good ( $R^2 = 0.94$ ). It was reported as the first time that such a high correlation was obtained between SEAT values and subjective ratings in a well-constructed experiment using high-quality psychophysical methodologies.



**Figure 2.9 The PSD of the *virtual reference* [Van Niekerk et al., 2002]**

SEAT values on the seatback in the longitudinal direction and overall averaged subjective ratings did not seem to correlate ( $R^2 = 0.46$ ). The SEAT values in the vertical direction of the seatback were very small (8% to 9%), did not vary significantly and were assumed to have little influence on dynamic seat comfort.

Van Niekerk proposed the combination of multi-axis SEAT values by computing the geometric mean, as is the approach for multi-axis vibration:

$$Comb_1 = \sqrt{SEAT_{seat\ top_z}^2 + SEAT_{seatback_x}^2 + SEAT_{seatback_z}^2} \quad (2.5)$$

The combination of SEAT values resulted in a correlation of  $R^2 = 0.78$ . This was worse than that obtained by only considering the contribution from the vertical direction on the seat top. It was argued that the values from the vertical direction of the seatback were very small compared to that on the seat top, and that they did not correlate with subjective ratings. It was suggested that only the vertical seat top and perpendicular seatback SEAT values should be used as shown in:

$$Comb_2 = \sqrt{SEAT_{seat\ top_z}^2 + SEAT_{seatback_x}^2} \quad (2.6)$$

The correlation remained at  $R^2 = 0.78$ , which was again attributed to the bad correlation between subjective response and SEAT values at the perpendicular seatback.

## ***2.7 Conclusions from the literature survey***

The minimal level of equipment required for the laboratory method of evaluating seat vibration is a vibrator, capable of driving a platform in the vertical direction. The objective evaluation of dynamic seat comfort requires vibration measurements in the vertical direction on the shaker platform and between the ischial tuberosities of the seated subject on the seat cushion. For vertical input vibrations, seatback measurements are recorded in the x- and z-directions of the basicentric axis system. SEAT value is an objective metric for the assessment of dynamic seat comfort and accounts for the characteristics of the vibration input at the seat track, the transmissibility of the seat and human sensitivity to vibration. Subjective dynamic seat comfort assessments conducted with the virtual seat method eliminate the effects of static seat comfort and the time delay between the evaluation of two different seats. A subjective assessment, using the virtual seat method, has been correlated with SEAT values on the seat top for a rough road stimulus with vibration energy between 12 and 17 Hz.



# Experimental rig

The dynamic seat testing facility (DSTF) is a man-rated shaker that was used for the laboratory evaluation of seat vibration. A discussion is dedicated to the characterisation of the experimental rig and the selection of test subjects and test seats. Carefully planned test methodology is illustrated by methods of consistent seat positioning and definition of the locations of vibration measurement. The techniques of road vibration measurement are reported along with the manipulation of the acquired signals to produce test stimuli. The final sections of this chapter demonstrate the accurate reconstruction of the test signals on the DSTF platform and test seats.

## ***3.1 The dynamic seat testing facility (DSTF)***

The dynamic seat testing facility (DSTF) is a man-rated system, situated in the Structures Laboratory of the University of Stellenbosch. It has a platform that provides for the mounting of test seats with seated subjects. The platform can oscillate vertically for the purpose of testing seat performance in dynamic conditions.

The rig comprises of a 100 kN servo-hydraulic test actuator (specifications listed in Table 3.1) that displaces a rigid aluminium platform in the vertical direction. A servo-hydraulic valve is controlled to move the actuator and simulate vertical road vibration on the platform.

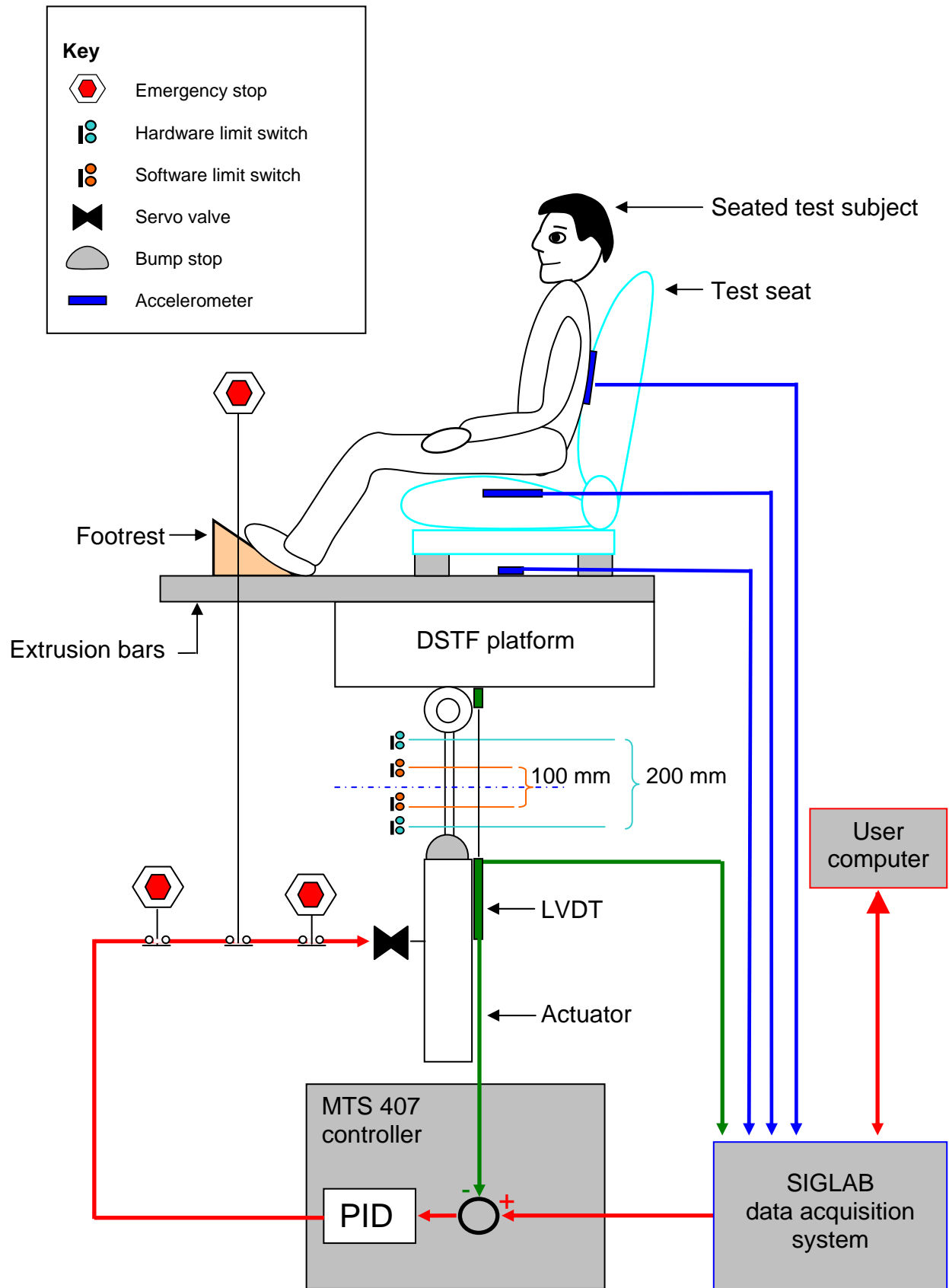


Figure 3.1 Diagram of the dynamic seat testing facility (DSTF)

Platform movement is monitored by an LVDT that gives feedback to a closed-loop PID controller inside the MTS 407 servo controller. The servo controller facilitates closed loop force and displacement control and is capable of sine and square wave signal generation from 0.4 – 100 Hz, with amplitudes of 0 – 10 V.

**Table 3.1 Actuator specification**

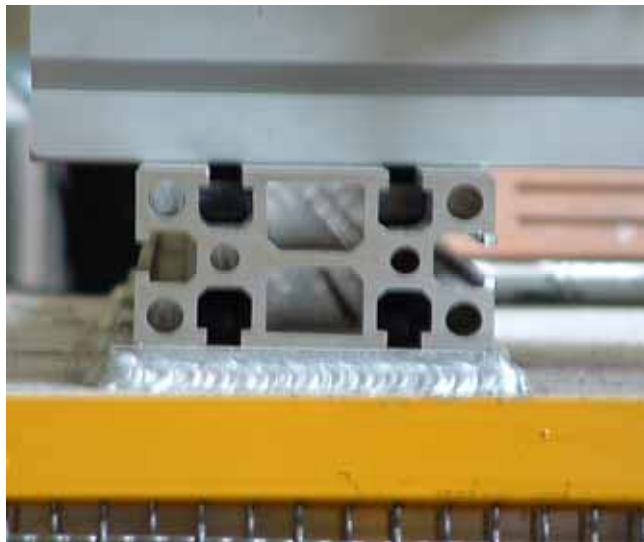
<i>Description</i>	<i>Specification</i>
Static force rating	100 kN
Dynamic force rating	75 kN
Stroke	200 mm ( $\pm 100$ mm)
Frequency range	0 - 25 Hz
Maximum velocity (non-continuous)	0.4 - 0.5 m/s
Bearings	Sealed, hydro-dynamic
Supply pressure	280 Bar

For the purposes of this study, platform vibrations were restricted to a frequency content of 0.5 – 20 Hz (the relevant frequency range for whole-body vibration in vehicles). Displacements did not exceed 50 mm about the centred actuator position.

A pair of aluminium extrusion bars is bolted to the platform. They extend beyond the platform to provide for the fastening of a 4 mm aluminium footplate. An angled wooden footrest is bolted to the footplate and creates foot support for seated subjects. An angle iron is welded across the footplate width to prevent vertical bending. An additional pair of aluminium extrusion bars can be bolted across the first pair (optionally) to add additional height to the mounting of test seats. The bars create an adjustable sliding system that allows for the versatile positioning of test seats, which is important due to the variation in subject length. Test seats are fixed to the rig by bolting the seat rails to steel blocks that slide inside the slots of the extrusion bars (Figure 3.2).

Subject safety is an essential consideration as the DSTF rig is a man-rated system. A chain rail restricts direct access to the testing area. Test subjects

access the test platform via a set of steps, provided with a safety rail. A grid screen guards the moving parts of the DSTF, restricting accidental access. Emergency stop buttons are located on the controller, within reach of the test subject and on the hydraulic feed line. The activation of any of these emergency stop buttons cuts the hydraulic circuit to the actuator and causes the platform to lower itself slowly to its bottom position.



(a)



(b)



(c)

**Figure 3.2 Aluminium extrusion bars (a) create a versatile sliding system (b) to which test seats are bolted (c) at the seat track**

The actuator is equipped with a bump stop and two sets of adjustable limit switches to eliminate the operation of the actuator outside its designed safe range. The hardware limit switches are set 200 mm apart and allow 100 mm displacement on either side of the centred operating position. The operator adjusts the software limit switches to accommodate the specific needs of a



particular experiment. In this study all input commands are specified in terms of displacement and therefore exposed to constant monitoring.

The input command signal is either generated or specified by the operator (such as reconstructing measured road vibration on the DSTF platform). The interface between the test control system (SigLab) and the user computer is facilitated by in-house software, written in MATLAB. SigLab (Table 3.2) is a computer-controlled data acquisition and test control system that is also capable of signal generation. The displacement command signal is sent through one of the output channels to the MTS 407 controller that controls valve operations and, therefore, the movement of the platform. The displacement response (measured by the LVDT) and acceleration measurements on the platform, seat top and seatback are recorded through the input channels of the data acquisition system.

**Table 3.2 SigLab and accelerometer specifications**

*SigLab specifications*

<i>Manufacturer</i>	<i>Description</i>	<i>Power supply</i>	<i>Model no.</i>	<i>Serial no.</i>
Spectral Dynamics	4 input channels, 2 output channels, 20 kHz BW	12 V DC @ 1.5 A or battery 7.2 V @ 1500 mAH	20 - 42	11760

*Accelerometer specifications*

<i>Manufacturer</i>	<i>Location</i>	<i>Direction</i>	<i>Type</i>	<i>Model no.</i>	<i>Serial no.</i>	<i>Sensitivity [mV/g]</i>
PCB Electronics	Platform	z	DC-capacitive	370D1FA20G	5551	100.3
PCB Electronics	Seat top	z	Seat-pad	356B40	21385	100.5
PCB Electronics	Seatback	z	Seat-pad	356B40	26977	102.3
PCB Electronics	Seatback	x	Seat-pad	356B40	26977	100.4

Seat responses are characterised by acceleration measurements on the platform (vertical), seat top and seatback (in-plane and perpendicular). The acceleration measurements are an indication of the character and magnitude of the forces that the seat exerts on a seated occupant.

The platform accelerometer is a DC-capacitive type accelerometer that enables accurate vibration measurement of frequencies from about 0.5 Hz. The use of this sensor results in benefits such as good transmissibility coherence at low frequencies (below 1 Hz).

Seat pad accelerometers are used on the seatback and seat top as prescribed in ISO 2631. They are tri-axial piezoelectric sensors with accurate acceleration measurement capabilities above 1 Hz. The relevant accelerometer specifications are shown in Table 3.2.

## ***3.2 Frequency response of the DSTF***

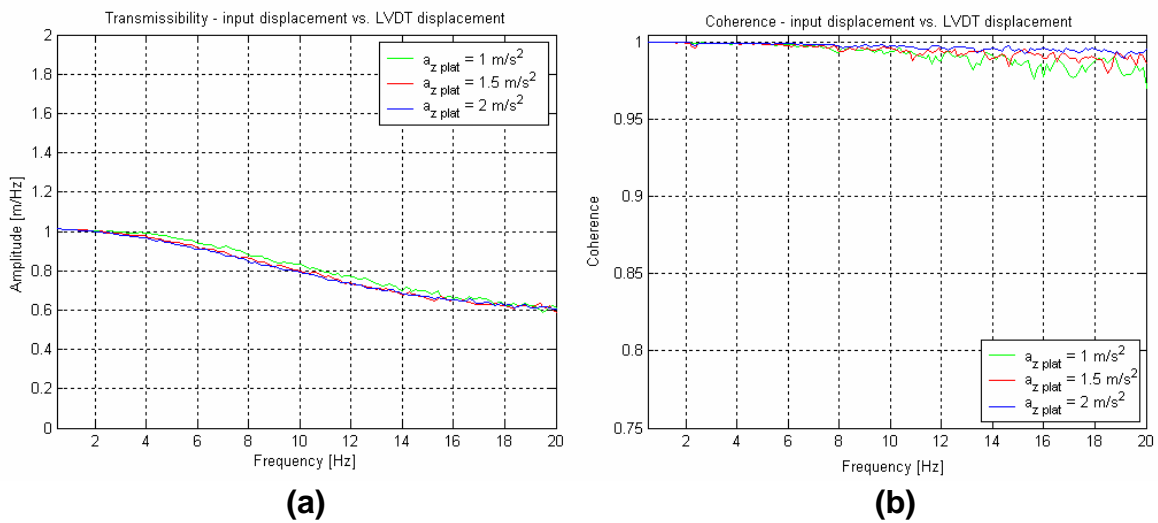
The floor-pan vibration of driven vehicles displays three vibration modes: **rigid body** mode, **seat-occupant** mode and **wheel-hop** mode. These three modes are the dominant sources of vibration input to seat. An investigation into dynamic seat comfort is predominantly occupied with how well the seat isolates the occupant from these vibration modes. Varterasian [1982] state that vehicle floor-pan vibration modes occur at frequencies below 20 Hz. This frequency range is adopted as the relevant frequency interval for the investigation of dynamic seat comfort in this study. Consequently, the experimental rig itself should be accurately controllable and should have no vibration modes in the 0 – 20 Hz frequency range.

### ***3.2.1 Transmissibility of the DSTF***

#### ***3.2.1.1 Input displacement vs. LVDT output***

The transmissibility of the input command and resultant response of the LVDT is expected to approach 1. This would imply that the response of the actuator and displacement, measured by the LVDT, is an exact response to the desired input signal. Figure 3.3 shows the measured transmissibility and

coherence functions between the input displacement and LVDT displacement (in the 0.5 – 20 Hz frequency range).



**Figure 3.3 Transmissibility (a) and coherence (b) of input displacement vs. LVDT displacement for different input levels**

At low frequencies, the system approximates an ideal response with a transmissibility approaching 1. The ratio of the resulting and desired response decreases with an increase in frequency and drops to 0.6 at 20 Hz. The reason is that the inertial effect of the platform practically increases with frequency as the entire mass of the platform has to change direction. Paramount to this, there is a time lapse between when the valve opens to allow oil flow and resultant actuator movement. This is due to the viscous effects of the oil flow and the capabilities of the system to produce the desired pressure instantaneously.

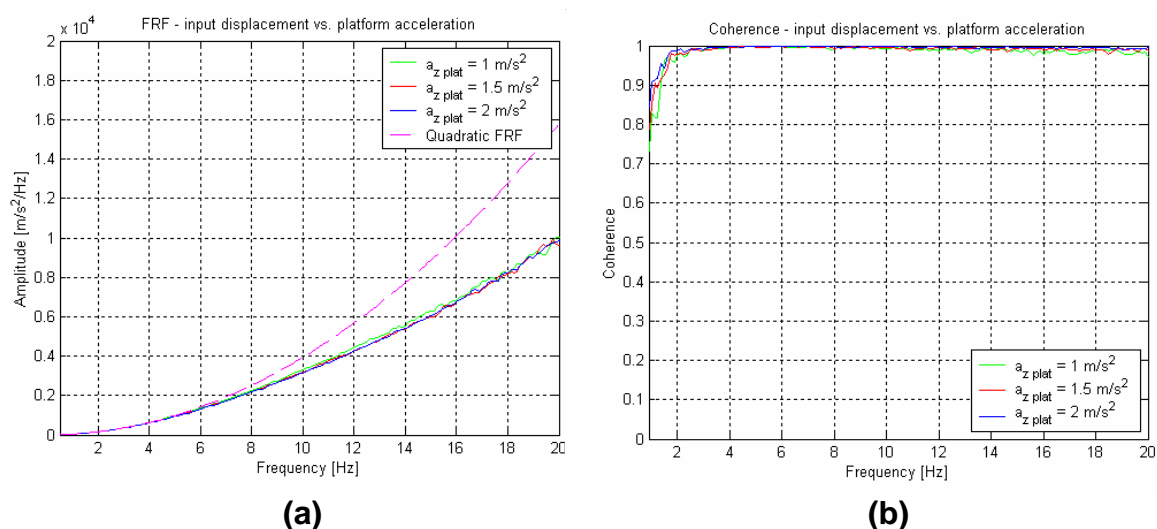
### 3.2.1.2 Input displacement vs. platform acceleration

The FRF of the input displacement signal and the acceleration of the platform centre increases almost quadratically with frequency. This is expected due to the relationship between acceleration and displacement described in Equation 3.1. As the displacement response of the LVDT is less than the ideal response at frequencies above 6 Hz, it is expected that the acceleration

response is less than the ideal quadratic FRF (dashed magenta line in Figure 3.4). Non-linearity is most significant at lower vibration magnitudes.

### 3.2.1.3 Modes of the DSTF

The exposure of subjects to road vibration with a frequency content of 0 – 20 Hz implies that the experimental rig may not display any vibration modes in this frequency range. If a mode occurs, a subject experiences the combined effect of the vibration modes of the test seat **and** experimental rig. This is undesirable as the focus of this study is on the response of human occupants to the dynamic characteristics of the **seat**.



**Figure 3.4 Frequency response (a) and coherence (b) of input displacement and the acceleration of the platform centre for different input levels**

In Appendix A it is shown that:

- Vertical vibration on the platform is uniform regardless of the location of measurement.
- The footplate-footrest assembly does not display vibration modes between 0 – 20 Hz.
- Lateral and fore-aft vibration is negligible.

Therefore, the DSTF is considered suitable for *dynamic seat comfort* testing below 20 Hz.

### 3.3 Test seats

The dynamic seat comfort of seven seats was tested (Table 3.3). Seat A, B, E, F and G represent a sample of contemporary car seats. Seat C is an air-suspension seat, usually found in trucks and earth-moving machinery (Figure 3.5).



**Figure 3.5 Seat A, B, C, E, F and G**

Seat A was arbitrarily chosen as the reference seat. The seat allows fore-aft adjustment along its seat rails and the variation of seatback angle. All the car seats, except Seat G, were designed for vehicles with typical on-road applications. The double cab pick-up is used in gravel and off-road terrain.

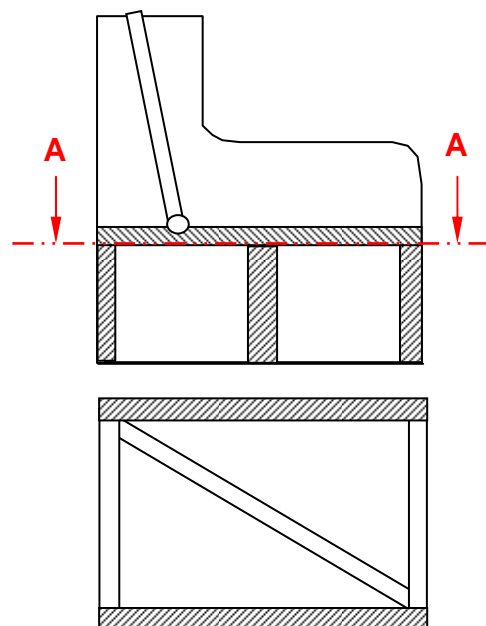
**Table 3.3 Test seats**

<i>Seat</i>	<i>Description</i>	<i>Year</i>
A	Luxury sedan	1997
B	Economy sedan	2003
C	Air-suspension truck	1996
D	Rigid wood	-----
E	Small pick-up	2003
F	Economy sedan	1999
G	Double-cab pick-up	2001

Seat D is a rigid wooden seat that was built inhouse. The chosen seats were selected to comprise of a sample that would intuitively result in a variation of ride comfort experiences. Seat D (Figure 3.6) has a box-like base, formed by solid side planks (shaped like armrests) and vertical supports that stretch across its width. It is rigidified by a vertical member that stretches diagonally from corner to corner (Figure 3.6 (b)).



(a)



(b)

**Figure 3.6 (a) Seat D (b) Middle and top sections of the rigid wooden seat**

The flat seat top is horizontally mounted between the “armrests” along the full length of the seat. A set of hinges is used to attach the flat backrest to the

seat base. The hinges provide for the adjustment of the *seatback* angle. It is screw fastened to the rigid side planks at the desired position.

### 3.4 Test subjects

Table 3.4 lists the description, weight and stature of the test subjects that took part in this study. They include three females and six males and range from 5<sup>th</sup> to 95<sup>th</sup> percentile individuals.

All nine subjects were exposed to 240 trials of paired comparison tests. These tests consisted of five different paired comparison schemes that were evaluated to decide on the best subjective ride comfort assessment procedure. These trials were also used to train the subjects in the distinction and perception of vibration levels.

**Table 3.4 Test subjects**

<i>Subject no.</i>	<i>Description</i>	<i>Weight [kg]</i>	<i>Stature [m]</i>
1	5 <sup>th</sup> percentile female	50.8	1.59
2	50 <sup>th</sup> percentile female	61.5	1.71
3	50 <sup>th</sup> percentile female	59.3	1.65
4	50 <sup>th</sup> percentile male	75.5	1.79
5	50 <sup>th</sup> percentile male	77.3	1.78
6	95 <sup>th</sup> percentile male	89.1	1.82
7	75 <sup>th</sup> percentile male	83.9	1.81
8	95 <sup>th</sup> percentile male	97.0	1.85
9	50 <sup>th</sup> percentile male	79.0	1.80

Subjects 1 to 6 participated in objective and subjective ride comfort tests. They were carefully selected to have the recommended gender, weight and stature for a representative profile recommended by literature [*Pielemeier et al., 1999*]. Subject 4 (highlighted in blue) was chosen as the reference subject for the purposes of this study.

### 3.5 Seat position and vibration measurement

#### 3.5.1 Consistent seat position

Different test seats were mounted in a position that remained consistent for each test subject. This ensured that the subject was seated similarly on different test seats, minimizing the effect of posture on experimental measurements. The consistent seat position was determined by implementing the advantages of the Seat Index Point (SIP) [ISO 7096:2001].

Table 3.5 Consistent seat locations for test subjects

Subject	h [mm]	b [mm]
1	380	465
2	380	490
3	380	480
4	380	490
5	380	570
6	380	600

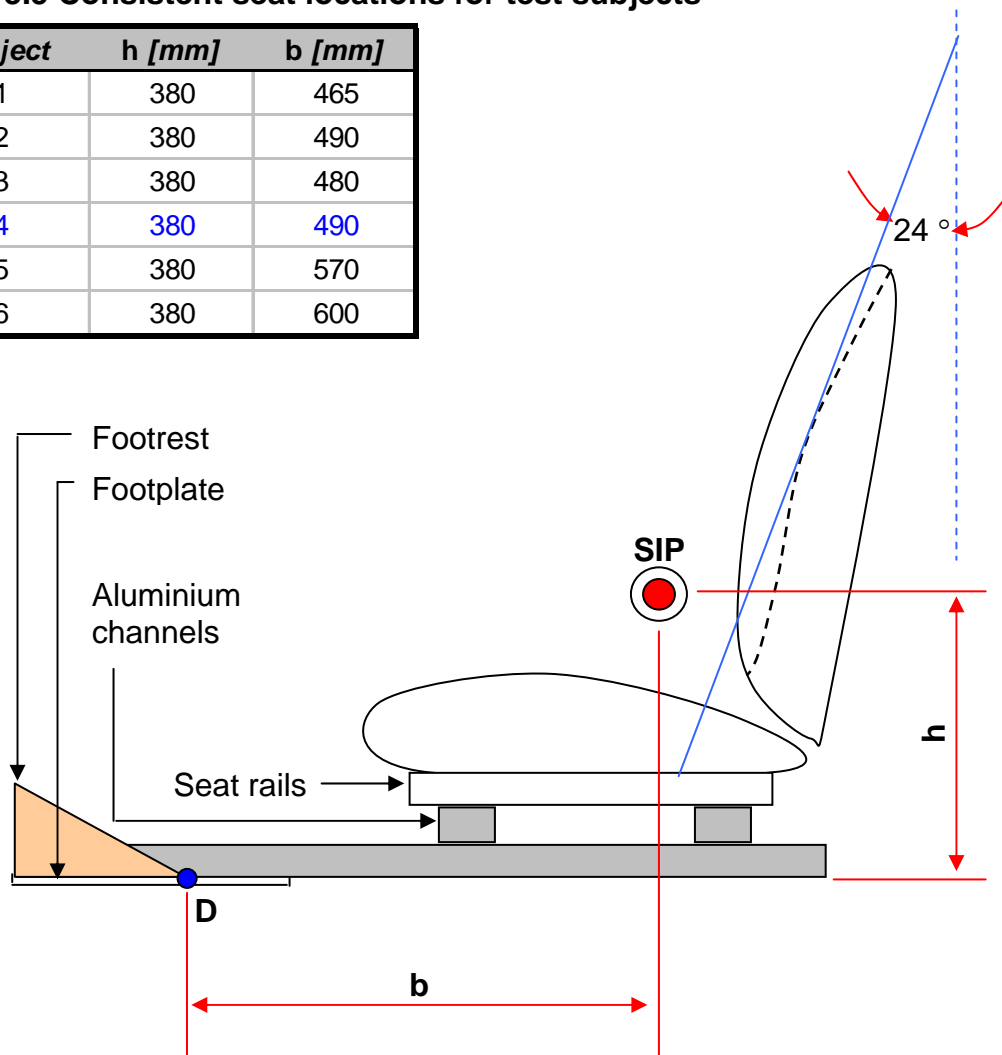


Figure 3.7 Consistent seat location parameters



The reference seat (Seat A) was mounted onto the DSTF platform, as shown in Figure 3.7 All seat settings were adjusted to the middle setting, with the seat backrest at 24° with the global vertical. The reference subject (Subject 4) was seated on the reference seat and instructed to place his heels at the intersection of the footplate with the sloped side of the footrest (line **D**). The mounting location of the seat (on the aluminium channels of the DSTF) was adjusted until the reference subject was seated comfortably, in the posture specified by ISO 7096. The reference seat was secured to the DSTF platform at this location. This step centres the seat position and adjustability range on the reference subject.

The SIP gauge [ISO 7096:2001] replaced the Subject 4 on Seat A. The SIP was determined relative to the point where the footplate intersects with the sloped side of the footrest. This position was noted as the consistent seat mounting location for Subject 4 (the reference subject) and used to position all other seats.

Each test subject was seated on Seat A, with all seat settings adjusted to the middle setting. Subjects were instructed to place their heels on line **D** and allowed to adjust the fore-aft position of the seat (the only other adjustable setting of the reference seat), until seated comfortably. Subject posture was checked against the specification of ISO 7096.

**Table 3.6 SIP heights and seat top angles for test seats**

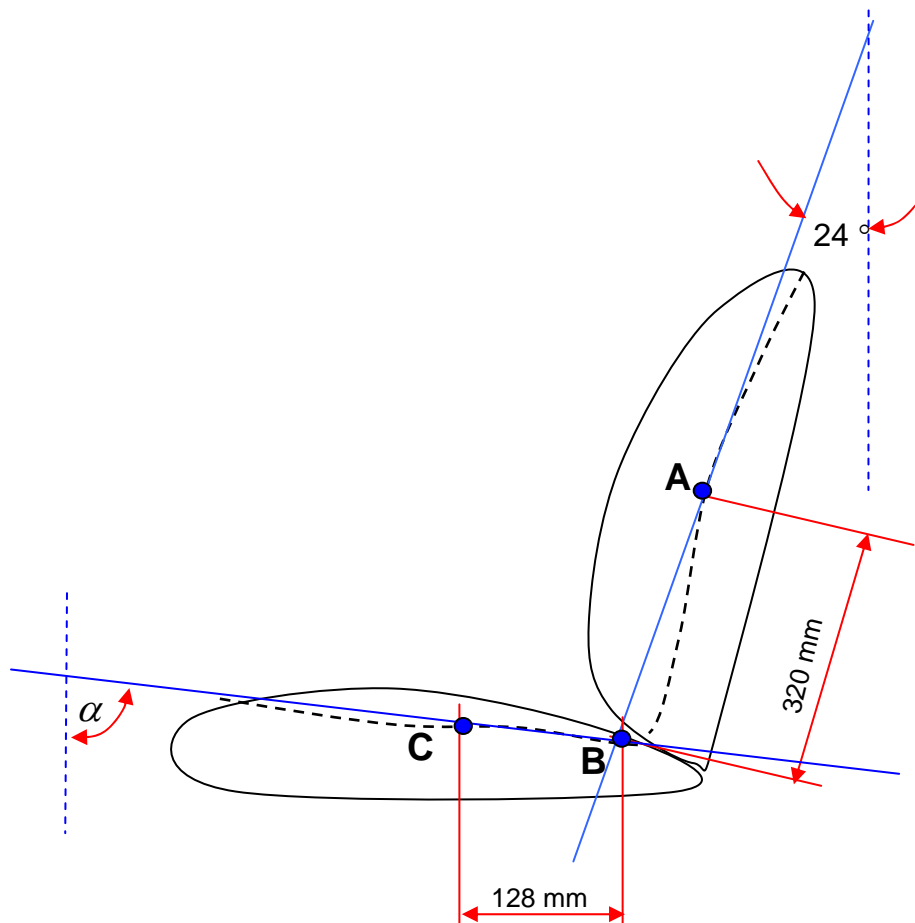
<b>Seat</b>	<b>Description</b>	<b>h [mm]</b>	<b><math>\alpha</math> [°]</b>
A	Luxury sedan	380	15.5
B	Economy sedan	374	8.3
C	Air suspension truck	400	15.3
D	Rigid wood	380	0.0
E	Small pick-up	376	14.1
F	Economy sedan	382	4.6
G	Double cab pick-up	380	14.0

The SIP was determined for each subject in this position. The location of the SIP relative to the intersection of the footrest with the footplate (line **D**) was

kept consistent throughout the testing of different seats for each subject. The consistent seat position for each subject is listed in Table 3.5.

Due to practical constraints, the exact consistent mounting of seats was not always possible in the height dimension (Table 3.6). The difference in subject posture due to this difference is negligible except for the case of Seat C, which was mounted significantly higher than the other seats.

### 3.5.2 Seat vibration measurement locations



**Figure 3.8 Seat measurement locations**

Point A (Figure 3.8) is located on the seat centre line, 320 mm from the uncompressed seat top cushion in the vertical direction of the seatback cushion plane. This point marks the position where the seatback

accelerometer is mounted bulge side down. Line AB is a tangential line through point A. Point B marks the intersection of the tangent with the seat top cushion when this line is at an angle of  $24^\circ$  with the global vertical. Point C is located 128 mm towards the front of the seat from point B in the plane of the seat top cushion. Another seat-pad accelerometer is placed at point **C**, bulge side up. The angle  $\alpha$ , of line **CB**, to the global vertical is noted.

### **3.6 Test stimuli**

The stimuli used for ride comfort tests are actual road data recordings, as seats should be rated on their ability to isolate occupants from realistic rough road vibration. The reconstruction of road vibration on different locations of the DSTF requires that the input displacement be estimated through the relevant transmissibility or FRF. A signal must be devised to ensure the accurate and reliable measurement of these functions for control purposes and objective ride comfort assessment.

Paired comparison tests are the basis of the subjective ride comfort procedure (discussed in detail in Chapter 4). The stimuli needed for this procedure is:

- i.) A set of *scaled alternative stimuli* that remain identical on the DSTF platform. These are produced by scaling the measured *road stimulus*.
- ii.) A *reference signal* that is measured on the surface of the reference seat after exciting DSTF alike to a measured road stimulus. This reference signal is reconstructed in every trial and remains identical on every tested seat for each tested subject.

This section describes the collection of road data and how it was processed to result in a suitable reference signal for paired comparison tests.

### **3.6.1 Determining the input vibration spectrum for transmissibility and FRF measurement**

The reconstruction of vibration on the DSTF platform requires the measurement of the relevant transmissibility and FRF between the system input command and the LVDT displacement output and platform accelerations.

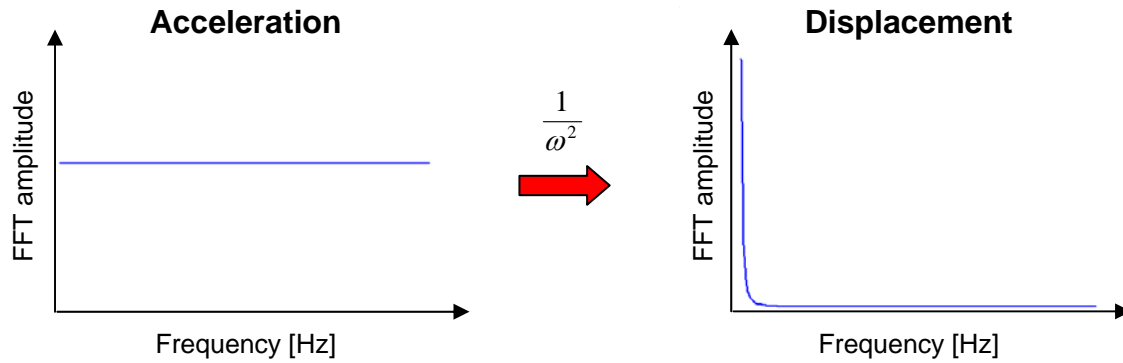
The input vibration spectrum should contain enough energy at all the frequencies in the 0 – 20 Hz range to result in a reliable transmissibility or FRF. One would instinctively choose an input command with a flat vibration spectrum. The choice of a flat vibration spectrum in the displacement domain results in a bad coherence function at the lower frequencies (below 3 Hz) when measuring FRFs between the input command and platform acceleration. This indicates that the signal has too little vibration energy in the lower frequency range.

This result motivates the choice of a flat input spectrum in the acceleration domain. The reasoning is that if the input displacement signal results in acceleration, with enough energy at all the frequencies in the 0 – 20 Hz range, a good coherence, and consequently a reliable FRF function, can be obtained. The relation between the amplitudes of the Fourier transforms of the displacement and acceleration signals is:

$$X(\omega) = \frac{A(\omega)}{\omega^2} \quad (3.1)$$

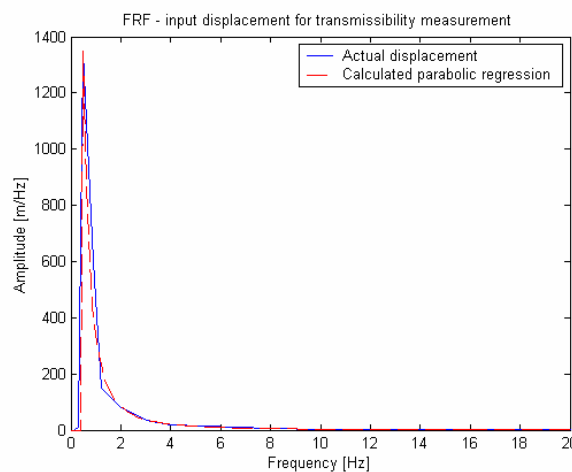
Where  $\omega$  is the frequency vector in rad/s. The shape of the input spectrum of a displacement signal,  $X(\omega)$ , resulting in a flat acceleration spectrum,  $A(\omega)$ , is shown in Figure 3.9. The shape of the input vibration spectrum is driven by the aforementioned argument and practical considerations. The practical realisation of an input displacement with infinite energy in the low frequency range is not possible. Low frequencies result in large displacements on the

platform of the DSTF, which is limited due to safety considerations and the physical limits of the test rig. All frequency inputs below 0.5 Hz and above 20 Hz where omitted.



**Figure 3.9 Profile of the displacement signal FFT that results in an acceleration signal with a flat FFT profile**

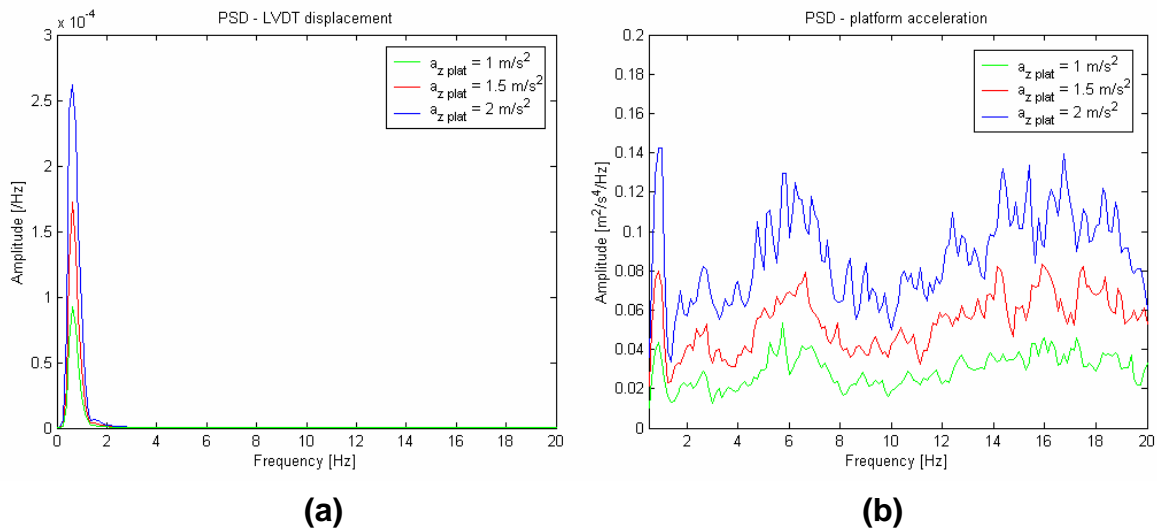
The final input displacement spectrum was chosen by trial and error to give good transmissibility measurements between the input displacement and resultant LVDT displacement, as well as good frequency response functions for the platform and seat accelerations.



**Figure 3.10 Calculated vs. actual input displacement spectra**

Figure 3.10 shows the correlation between the shapes of the actual and calculated input displacement spectra. The input displacement time signal is calculated by determination of the inverse Fourier transform of the

displacement spectrum. The time signal is *scaled* to the desired r.m.s. displacement value. All transmissibility function and FRF measurements are specified in terms of the r.m.s. acceleration magnitude on the DSTF platform with a frequency content of 0.5 – 20 Hz



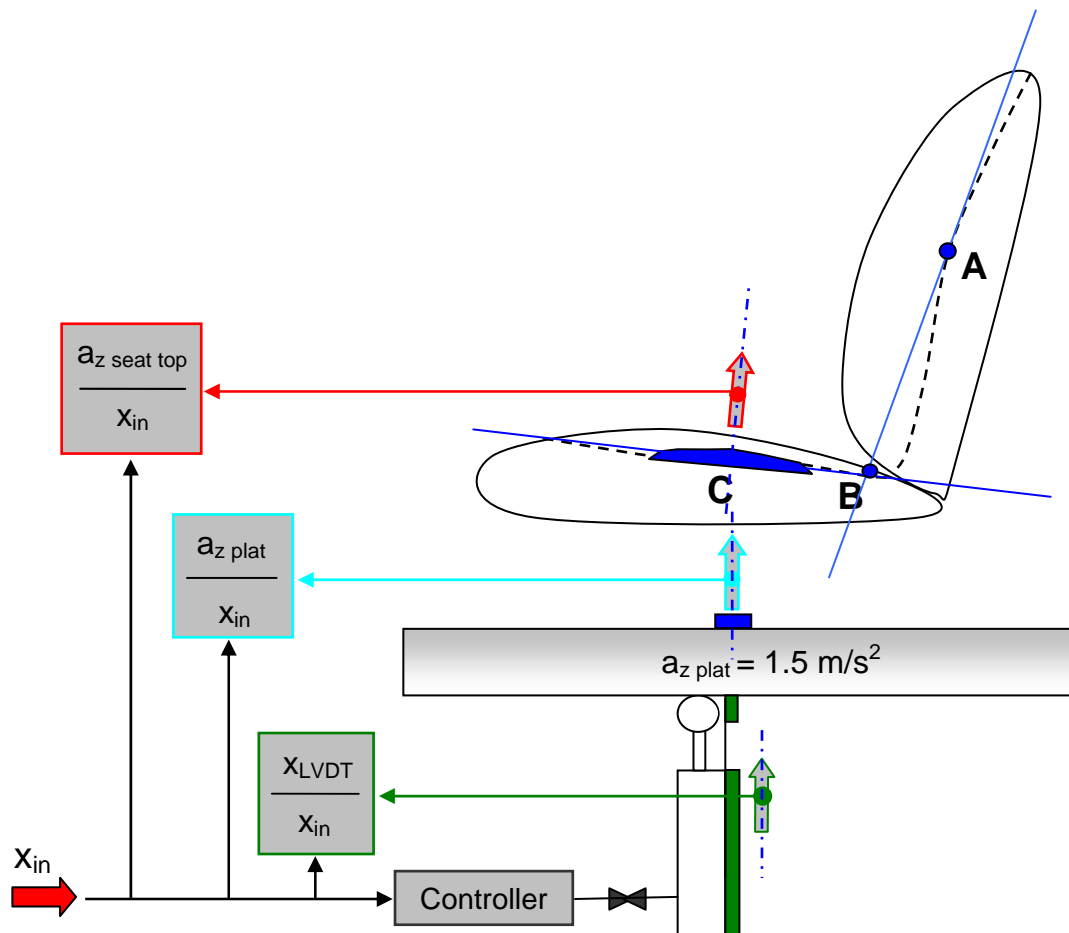
**Figure 3.11 Actual PSD of (a) LVDT displacement and (b) platform acceleration during transmissibility and FRF measurement**

Figure 3.11 shows the measured LVDT displacement and platform acceleration PSDs obtained when using the specified FFT profile. The platform acceleration shows vibration peaks at 1 Hz, 4 - 8 Hz and 12 - 19 Hz. Transmissibility measurements, using this input spectrum, produced good coherency results. Therefore, no more attention was afforded to obtaining a flatter platform acceleration spectrum for transmissibility measurement.

### **3.6.2 Measurement of frequency response functions**

Frequency response functions (FRFs) were measured to characterize the response on the seat-occupant system with regards to the input command (Figure 3.12). The FRFs were used for the estimation of the input displacement for vibration reconstruction on the platform or seat top.

Input displacements for the measurement of seat transmissibility were specified by the input displacement frequency profile. The input displacement was scaled to result in platform vibration with an r.m.s. value of  $1.5 \text{ m/s}^2$  and a frequency content of  $0.5 - 20 \text{ Hz}$ .



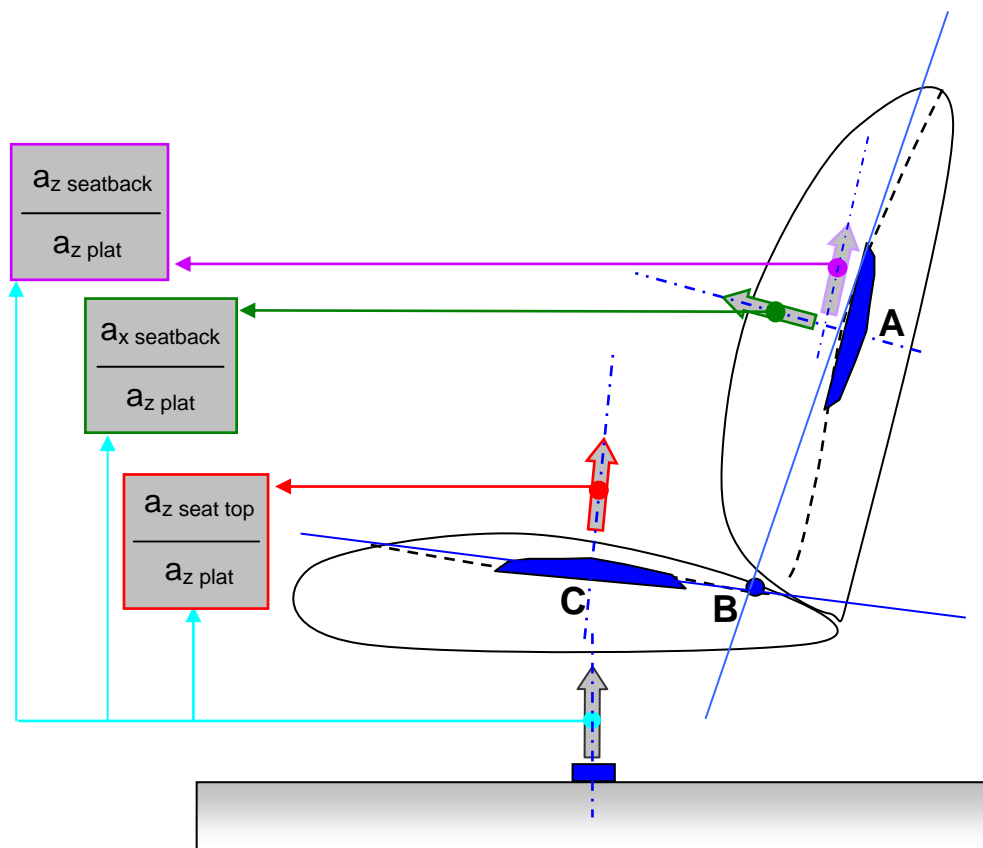
**Figure 3.12 Measured system transmissibility and FRFs**

**Three frequency response functions** were measured at a platform vibration magnitude of  $1.5 \text{ m/s}^2$  r.m.s. These included the FRF between the:

- **Input displacement command ( $X_{in}$ ) signal and vertical platform acceleration ( $a_{z \text{ plat}}$ );**
- **Input displacement command ( $X_{in}$ ) and vertical seat top acceleration ( $a_{z \text{ seat top}}$ );**
- **Input displacement command ( $X_{in}$ ) and the LVDT output response ( $X_{LVDT}$ ).**

### 3.6.3 Seat transmissibility measurement

Seat transmissibility functions were measured to characterize the acceleration response of the specific seat-occupant system in the frequency domain. Measurements were made at different vibration magnitudes to provide for the non-linearity of the seat-occupant system. Seat transmissibility functions were used for the estimation of seat vibration in an indirect method of SEAT value calculation (Section 2.4).



**Figure 3.13 Measured seat transmissibility functions and magnitudes**

The input displacement command signal was scaled to result in platform vibrations with r.m.s. values of  $0.5 \text{ m/s}^2$ ,  $1 \text{ m/s}^2$ ,  $1.5 \text{ m/s}^2$  and  $2 \text{ m/s}^2$  and a frequency content of  $0.5 - 20 \text{ Hz}$ . **Three seat transmissibility functions** were measured for each vibration magnitude:  $0.5 \text{ m/s}^2$ ,  $1 \text{ m/s}^2$ ,  $1.5 \text{ m/s}^2$  and  $2 \text{ m/s}^2$  (Figure 3.13). The transmissibility between:



- **Vertical acceleration** on the **platform** ( $a_{z\_plat}$ ) and **vertical acceleration** on the **seat top** ( $a_{z\_seat\ top}$ )
- **Vertical acceleration** on the **platform** ( $a_{z\_plat}$ ) and the **seatback acceleration (in-plane vertical** ( $a_{z\_seatback}$ ))
- **Vertical acceleration** on the **platform** ( $a_{z\_plat}$ ) and the **seatback acceleration (perpendicular to seatback plane** ( $a_{x\_seatback}$ ))

### **3.6.4 Road data recording**

The road accelerations were measured while driving on the badly corrugated sections of the gravel road to Hangklip, between Pringle Bay and Betty's Bay in the Western Cape (Figure 3.14(a)). The road surface is a combination of rocks and sand on a straight, slightly sloping section.



**(a)**

**(b)**

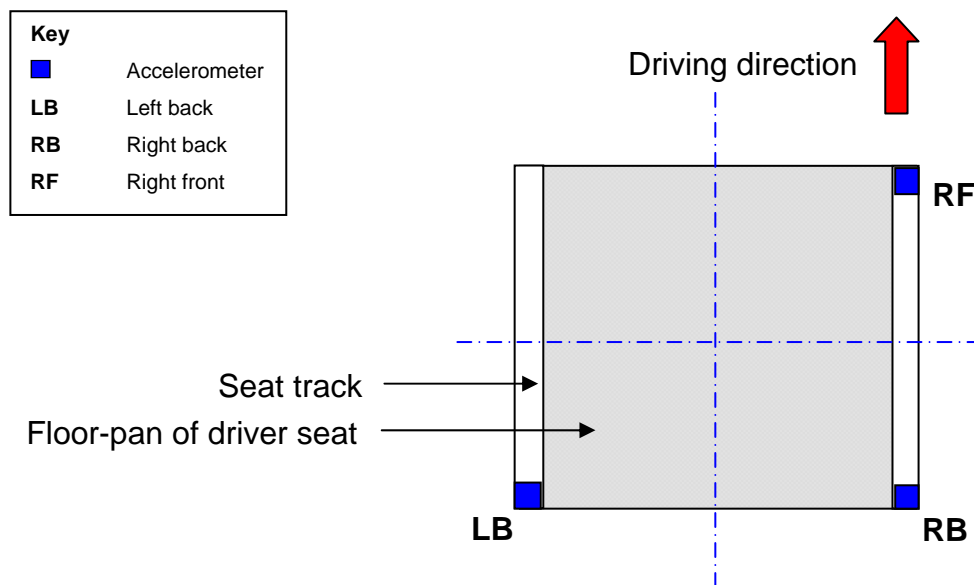
**Figure 3.14 The (a) Opel Corsa 1.3 L Lite and the (b) badly corrugated gravel road between Hangklip and Betty's Bay, Western Cape**

Acceleration measurements were made at three locations on the seat track of the driver seat of a 1997 Opel Corsa 1.3 L Lite (Figure 3.14 (b)), at 60 km/h to obtain 16 s acceleration recordings. The locations of the accelerometers on the seat track are shown in Figure 3.15.

The acceleration in the middle of the seat is approximated by:

$$a_M(t) = \frac{1}{2}(a_{RF}(t) + a_{LB}(t)) \quad (3.2)$$

Where  $a_M(t)$  is the acceleration time signal under the middle of the seat and  $a_{LB}(t)$  and  $a_{RF}(t)$  are the left-back and right-front seat track acceleration measurements. The third accelerometer at the right-back of the seat track suffices to detect suspect measurements.

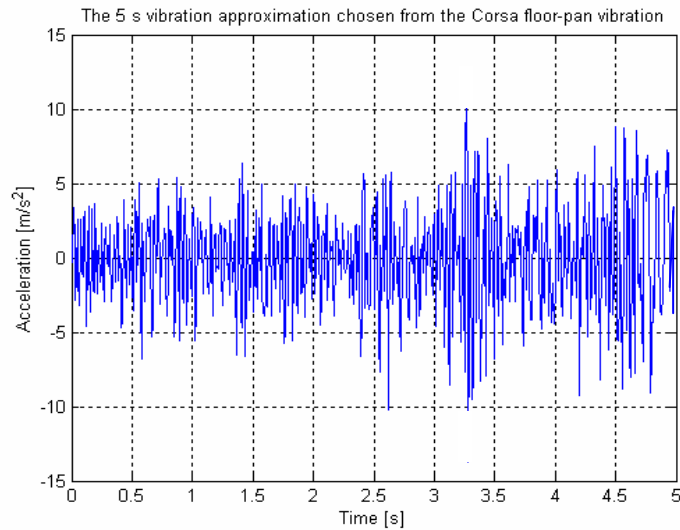


**Figure 3.15 Diagram of accelerometer placement for road data recording**

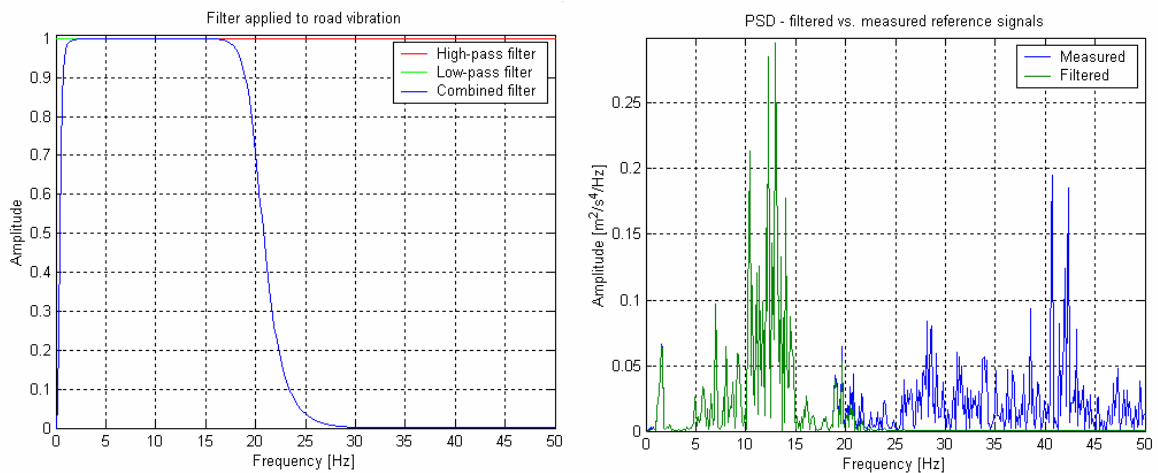
A 5 s acceleration approximation was chosen from the Corsa floor-pan vibration in the middle of the seat (Figure 3.16). A rough vibration was chosen, without characteristics that would base a subject's ride comfort assessment on one vibration event within the signal (this step was in fact an iterative process). Events that could singularly bias a subject's decision include excessive acceleration, like impulsive motion or large, rapid displacements.

A band-pass filter was applied to the road data recording, eliminating all vibrations outside the 0.5 – 20 Hz range (Figure 3.17 (a)). The filtered vibration was scaled to have an r.m.s. value of 1.5 m/s<sup>2</sup>. A comparison between the measured and filtered road data PSDs (in Figure 3.17 (b)) show that the band-pass filter does not remove the vehicle body modes from the

vibration. The Corsa displays a rigid-body mode (1 – 2 Hz) and seat-occupant mode (5 – 9 Hz). Wheel-hop mode is in the frequency range of 10 – 15 Hz, which is suspected to coincide with the frequency of the road corrugation in this case.



**Figure 3.16 The 5 s vibration approximation chosen from the Opel Corsa floor-pan vibration**



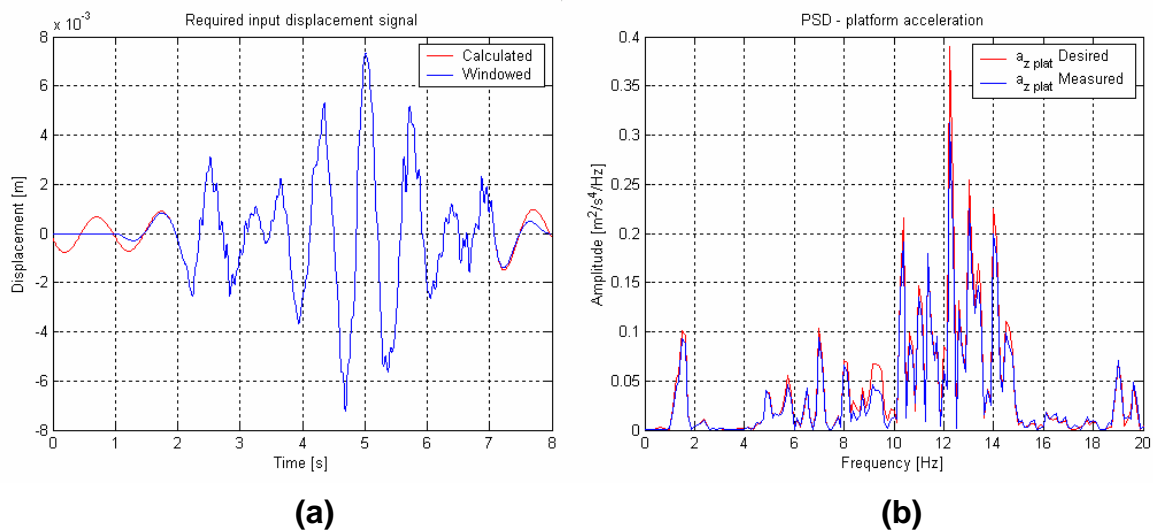
**Figure 3.17 (a) The band-pass filter applied to road vibration recordings and (b) the filtered and unfiltered reference signal PSDs**

### 3.6.5 Constructing the reference signal on the seat top

The SigLab system communicates one block of data to the controller at a time. The block length is 1024 points or 8 s of data at a sampling frequency of 128 Hz. The filtered floor-pan acceleration (with 1.5 m/s<sup>2</sup> r.m.s.) was padded

with zeros to create an 8 s vibration signal (2 s of zeros, 5 s of road data and 1 s of zeros).

The 8 s, signal was reconstructed on the DSTF platform with Subject 4 seated on Seat A. A displacement input signal was calculated from the FRF between the input displacement and platform acceleration for the reference subject (Subject 4) on the reference seat (Seat A) at  $1.5 \text{ m/s}^2$ . This input displacement signal is windowed, resulting in a smooth motion with a maximum displacement of 7.5 mm that starts and finishes in the centred platform position. The signal is “ramped up” for 1 s, followed by 3 s of pure floor-pan vibration and “ramped down” to the starting position for 1 s. The difference between the calculated and windowed input displacement signals are shown in Figure 3.18(a).



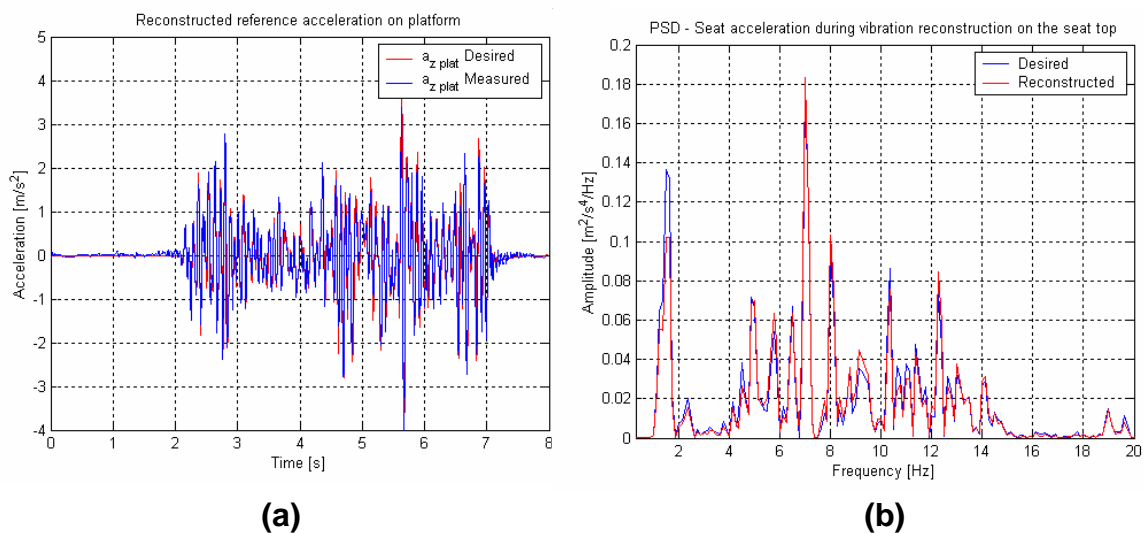
**Figure 3.18 (a) Calculated vs. windowed input displacements for reproducing the (b) desired and reconstructed floor-pan vibration on the DSTF platform**

Windowing the calculated input displacement has an effect on the resultant platform acceleration. The difference between the desired and reconstructed platform acceleration is shown in Figure 3.18 (b). The differences between the windowed and measured floor-pan accelerations is most prominent at 9 Hz and 12 Hz, but is still considered to represent realistic vehicle motion. The acceleration, measured on the seat top when the floor-pan acceleration is

reconstructed on the platform, is the *reference signal* used for paired comparison tests.

For the purposes of the virtual seat method, the *reference signal* has to be reconstructed to be identical on the seat top for each subject on each test seat. One JND for human perception of whole-body vibration is approximately 10%. This is set as the maximum limit for the deviation of the *reference signal* as a larger error in vibration reconstruction represents a perceptible difference in whole-body vibration. The error is calculated in the time and frequency domain.

Figure 3.19 shows an example of the error in vibration reconstruction for a 95<sup>th</sup> percentile female seated on Seat A. Even though the body dynamics of a 95<sup>th</sup> percentile female varies greatly from that of the reference subject (a 50<sup>th</sup> percentile male), the vibration reconstruction seems excellent in both the time and frequency domains.



**Figure 3.19 Reconstruction of the *reference vibration* for different subjects in the (a) time domain and the (b) frequency domain**

The input command signal is estimated from the relevant FRF between the *input displacement* and *seat top acceleration* for the 95<sup>th</sup> percentile female on Seat A at  $1.5 \text{ m/s}^2$ . The error in the construction of the *reference signal* is

checked in both domains to be below 10% throughout subjective ride comfort testing.

### **3.6.6 Reconstructing scaled alternatives on the DSTF platform**

The filtered road vibration of  $1.5 \text{ m/s}^2$  was scaled to produce alternative stimuli on the shaker platform. The input displacement was estimated from the FRF between the input displacement and platform acceleration. Alternative platform accelerations are scaled 1 JND apart (thus a scaling factor of 1.1 is used). The scaling of alternative stimuli was different for different experiments and will be discussed in the relevant sections of this dissertation. What is of utmost importance, however, is that the alternative stimuli reconstructed on the platform must be identical for all test seats and test subjects. The error of the reconstruction of the alternative stimuli on the platform is monitored in the time and frequency domains at all times.

## **3.7 Conclusions on the experimental rig**

Six carefully selected subjects were chosen to participate in the assessment of seven test seats. The effect of varying subject posture is eliminated by implementing the advantages of the SIP.

The random vibration used for FRF and transmissibility measurement results in good coherence and, therefore, reliable measurements. A scaled rough-road vibration measurement with an r.m.s. value of  $1.5 \text{ m/s}^2$  at the seat track was used to generate the *reference stimulus*. The *alternative* stimuli are scaled versions of the road vibration recording at the seat track. The frequency content of this stimulus differs from the signal used by Van Niekerk et al. [2002] in that it contains rigid body mode (below 2 Hz) and vibrations between 4 Hz and 10 Hz.

The reconstruction of the *reference stimulus* on the seat top was achieved by the estimation of the input command signal through the relevant FRF. The

resultant response on the seat top is within 10% accurate in both the time and frequency domain.

The methodologies discussed in this chapter prove that the DSTF rig is capable of conducting the laboratory assessment of dynamic seat comfort.



# Subjective test procedures

The purpose of this chapter is to further the discussion on the use of paired comparison techniques for subjective dynamic seat comfort assessment (introduced in Section 2.5.2). The significant advantages of the Levitt adaptive procedure is described and compared to the shortcomings of the psychometric method of constants. Difficulties encountered when using simple up-down Levitt procedures can be overcome by the use of interleaved tracks and 2-up-1-down methods. The performance of five subjective dynamic seat comfort assessment procedures is discussed in an experimental comparison. The choice of the most accurate and efficient method is motivated from criteria investigated in this chapter.

## ***4.1 The Levitt adaptive procedure***

The Levitt procedure is an adaptive procedure in which the stimulus level on any trial is defined by the preceding stimuli and responses [Levitt, 1970]. It is an up-down procedure that falls in the general class of sequential experiments, where the choice of stimulus level is dependent on the experimental data (i.e. the previous choices of the subject).

Belmann et al. [2000] has implemented the Levitt procedure for subjective level of equivalence testing. This approach has not been used for subjective dynamic seat comfort assessment. Pielemeier et al. [1999] proved that a significant correlation exists between subjective dynamic seat comfort levels,



determined by the psychometric method of constants, and objective dynamic seat comfort.

The Levitt procedure is based on the same principles as the psychometric method of constants, but is more efficient and accurate. This chapter analyses the potential advantages of using an adaptive paired comparison procedure for subjective dynamic seat comfort assessment.

#### ***4.1.1 Shortcomings of the method of constants***

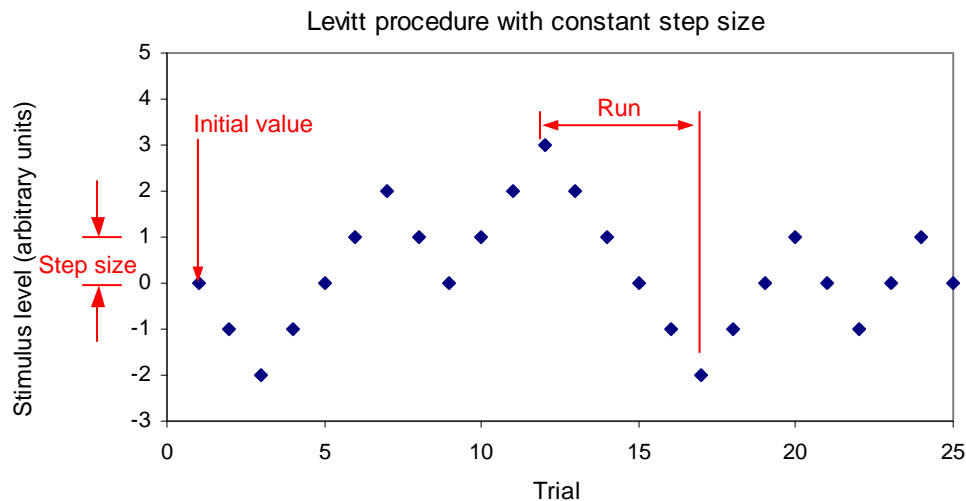
The method of constants proves to be inefficient if one is interested in estimating only one point on the psychometric curve (as is the case here, where only the point of subjective equality is to be determined). This inefficiency is caused by:

- The fact that a large number of observations are placed at some distance from the point of interest.
- The data is pooled at the predetermined stimulus levels, and that a curve is fitted through the pooled data. This approach does not allow for gradual changes in parameter values during the course of the test.
- Difficulties arise with small samples as slope estimates in particular are highly variable and subject to substantial biasing effects with small samples [Levitt, 1970].

#### ***4.1.2 A simple up-down or staircase method***

The simple up-down method (Figure 4.1) is a relatively efficient method for estimating the 50%-threshold. Stimuli are still played in pairs consisting of the *reference vibration* and an *alternative stimulus*. The *alternative stimulus* level is *decreased* if the *reference vibration* is found to be *more comfortable* than the *alternative vibration* (**positive response**) or *increased* if the *reference* is found to be *less comfortable* than the *alternative* (**negative response**).

A **reversal** is defined as the change from a positive to a negative response (or vice versa) between consecutive trials. The increments by which the stimulus is either increased or decreased are referred to as “**steps**”. A series of steps in one direction is defined as a “**run**”. The stimulus level used on the very first trial is the “**initial value**”.



**Figure 4.1 A Levitt procedure with constant step size**

### ***4.1.3 Advantages and disadvantages of the simple up-down technique***

The greatest advantages of the simple up-down technique are:

- Greater efficiency in the placement of observation points, where most observations are placed near the point of subjective equality. If there is a gradual drift during the test the placing of observations will follow this drift.
- This procedure converges more rapidly than the method of constants with the possibility of greater accuracy since the step size can be changed as the algorithm converges.

Disadvantages include that:

- Data is not well placed for estimating points other than the 50% threshold.

- If a too large step size is used, the data will be badly placed relative to the subjective point of equivalence. A too small step size will result in a very slow convergence to the 50% threshold. The choice of a too small initial step size can be disastrous in terms of the rate of convergence (25% - 100% slower). This problem will be further aggravated if a poor initial value is chosen.
- The third shortcoming is peculiar to the psychophysical testing in that the subject realizes that a sequential rule is being used and adjusts his/her responses accordingly.

#### **4.1.4 Analysis**

There are several methods of analysing data, using an up-down testing procedure. One method is to pool data and to fit the psychometric function, using conventional techniques. This method is based on the same assumptions relevant to the method of constants.

An extremely simple method of estimation is that in which the peaks and valleys of all the runs are averaged to provide an estimate for the 50% threshold. For this method of analysis, it is suggested that an even number of runs be used to reduce estimation bias. This approach is equal to taking the midpoint of every second run as an estimate for estimating the point of subjective equality (they are defined as **mid-run estimates**).

Mid-run estimates are robust, relatively efficient, and low in estimation bias, provided the response curve is relatively symmetrical about  $p_{50}$  (the 50% threshold). Mid-run estimates have the additional advantage that the sequence of contiguous estimates provides a direct indication of any significant drifts with time in the location of the response curve.

Bellmann suggests calculating the median from the stimulus data to determine the point of subjective equality for each *reference* signal [Bellmann et al., 2000].

## **4.1.5 Overcoming the difficulties of the simple up-down procedure**

### **4.1.5.1 Step size**

In the event that little is known about either the spread or the location of the psychometric function, it is recommended that a large initial step size be used and gradually decreased during the course of the experiment. The method of reducing step size leads to maximal or near maximal rate of convergence on the target stimulus level [Levitt, 1970].

Robbins & Monroe [1951] suggested that the step size on trial  $n$  should be equal to  $\frac{c}{n}$ , where  $c$  is a constant. The variance of the asymptotic distribution of stimulus values about  $p_{50}$  is minimised if the constant  $c$  is equal to  $\frac{0.5}{b}$ , where  $b$  is the slope of the response curve near  $p_{50}$ .

Another practical approach is to reduce the step size by a proportionate amount after each direction change in practical problems. This approach is based on the assumption that the response is linear in the region of the target value.

The initial step size should be guessed or concluded from previous experiments. The final step size is limited to the human perception threshold, by a minimum step size of one JND or 1.5 dB [Bellmann et al., 2000].

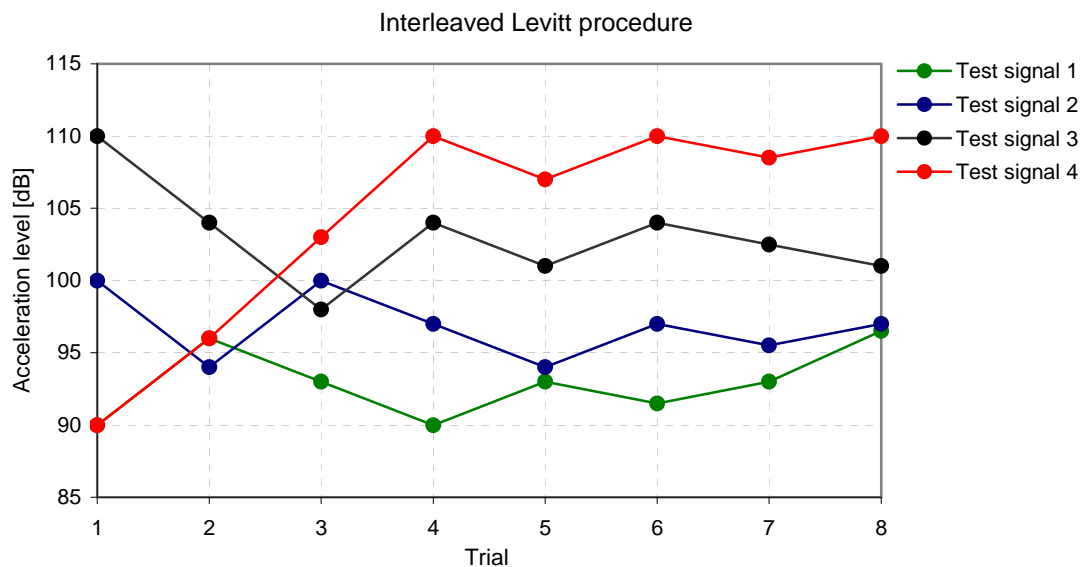
### **4.1.5.2 Reduce bias occurring with only one stimulus pair**

The use of **several interleaved adaptive tracks** (more than one *reference signal*) reduces the bias that occurs due to the direct correlation between the accuracy of the observer's response and the difficulty of the decision task on the next trial [Jesteadt, 1980].

“**Interleaved**” means that several adapting measurements with **different reference stimuli** and starting conditions are measured **simultaneously** [Bellmann et al., 2000].

Interleaving is beneficial (Figure 4.2), as it eliminates the certainty that the stimulus on the next trial will be similar to the current one or that any given response will have an influence on the next stimulus. These are the principal sources of sequential response biases in the method of limits.

For each trial, the *reference* track is chosen randomly from all possible *reference* tracks that have not yet converged. To ensure that the interleaved tracks converge at roughly the same time, the random choice of tracks is further restricted by the following rule: If none of the tracks are converged, the number of trials or all the different tracks have to be the same before the next trial for all tracks can be presented, in random order, to the listener. If one track is terminated, the same rule is applied to the remaining *reference* tracks. The *reference vibration* remains fixed within each series of trials.



**Figure 4.2** A four-track interleaved Levitt procedure [Bellmann et al., 2000]

#### 4.1.5.3 Judgement of subjectively equal stimuli [Jesteadt, 1980]

A major problem related to all conventional procedures is that they require the observer to evaluate stimuli that are close to being subjectively equal to the *reference signal*. Observers have difficulty with maintaining a consistent criterion when required to make extremely difficult judgements and are often discouraged by the impression that the decisions they are required to make are essentially arbitrary. An explanation that there is no objective criterion for a

correct response does not motivate a more stable performance. Consequently, subjective judgement tasks are found to be very tedious.

#### **4.1.6 The 2-up-1-down Levitt procedure**

Jesteadt [1980] proposes a combination of a subjective choice criterion with a two-track, interleaved Levitt procedure. **Both** interleaved tracks use the **same reference signal** for their paired comparison trials (Figure 4.3).

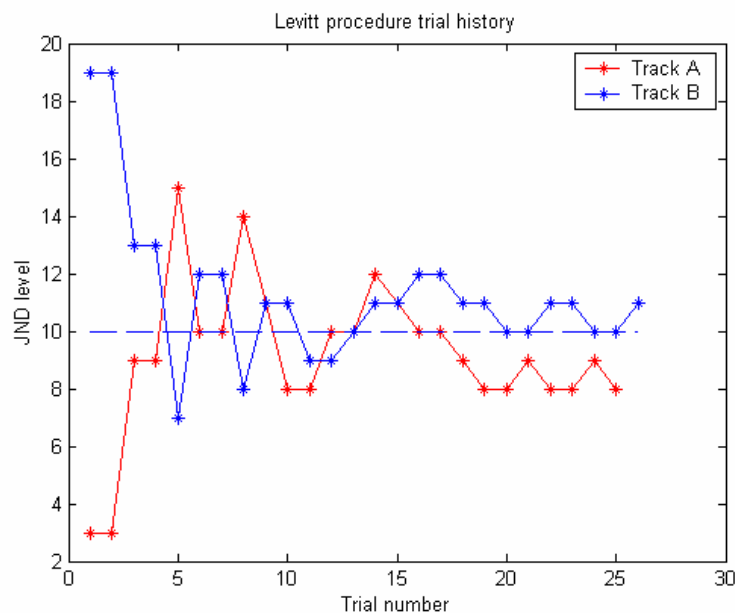
One of the tracks, which we refer to as the “A sequence”, is started at a level well **above** the *reference*, so that the *reference signal* will be chosen as **more comfortable** at the start. If the *reference* is chosen **twice in a row**, the level of the *alternative* is **decreased**. This continues until the *reference* is chosen **once** as rougher, at which point the level of the *alternative* stimuli is **increased**. The result is that the subject converges to a level **where the reference is more comfortable** than the **alternative stimuli 71%** of the time (just as a Levitt 2-down-1-up objective criterion, which gives the same percentage).

The “A sequence” is interleaved with an opposing “B sequence”, which starts at a **distinctly lower** level than the *reference*. The *alternative level* is shifted **up** if the comfort of the **alternative is preferred** to the *reference twice in a row*. The *alternative level* is **decreased immediately** if the **reference is the preferred** comfort level. The “B sequence” converges to a level where the **reference is preferred 29% of the time**.

The estimates of the 71% and 29% convergence points are determined by **averaging the reversal points within each sequence**. **The point of subjective equivalence is calculated by averaging the convergence values from sequence A and B**. This requires the assumption that the psychometric function is linear between the 29% and 71% points. The differences between the 50% points estimated by linear interpolation and by assumptions of non-linear psychometric functions are smaller than the error of measurement [Jesteadt, 1980].

This procedure has additional advantages in that the subject does not need to make too many choices between stimuli which are very close to subjectively equal. For the “A sequence”, the *reference signal* is the dominant preference, whereas the “B sequence” is biased towards the *alternative stimulus*. The decision rule therefore does not continually select stimuli near the point of subjective equality, but focuses instead on points above and below it.

The observer’s task is not to match the *reference*, but to classify stimuli with respect to the *reference*. The A sequence has the *reference* stimulus as the dominant *preference*, whereas the B sequence has a biased choice towards the *alternative*.



**Figure 4.3 A 2-up-1-down, interleaved Levitt procedure**

The decision rule operates at a point that keeps the level of difficulty at a point where 71% of the judgements are “correct” in the sense that they are consistent with previous judgements. A decision rule that maintains two distinctly separate sequences of trials creates a task where the observer is asked to discriminate between stimuli belonging to one sequence and those belonging to another. One of the greatest advantages of this procedure is that it appears to the observer as an objective task.

## **4.2 Experimental comparison of subjective dynamic seat comfort assessment procedures**

Subjective ride comfort tests are extremely time consuming. The most promising subjective dynamic seat comfort test procedures explored in the literature survey were selected and compared in a practical test to determine the most accurate and effective approach.

The subjective level of equivalence is unknown when subjective tests are conducted. This makes it difficult to estimate the reliability and accuracy of the subjective test procedure as there is no known “correct” answer for the convergence level. The comparison of subjective paired comparison procedures would, therefore, entail devising a test where the subjective level of equivalence is known.

### **4.2.1 Method**

The  $1.5 \text{ m/s}^2$  road data recording (discussed in Chapter 3) was scaled to produce 20 alternative stimuli that are 1 JND (approximately 10%) apart. The  $1.5 \text{ m/s}^2$  road data recording was named, “Alternative 10” with ten smaller and nine larger, scaled alternatives. The **smallest** of these, “Alternative 20”, had an r.m.s. value of  $1.5 / 1.1^{10} = 0.58 \text{ m/s}^2$ , and the **largest**, “Alternative 1”, had an r.m.s. value of  $1.5 \times 1.1^9 = 3.54 \text{ m/s}^2$  (note that the mentioned r.m.s. values are for unweighted vibrations, band-limited between 0.5 and 20 Hz). Figure 4.4 illustrates the scaling process.

**Alternative 10 was chosen as the reference signal** for the purpose of testing the accuracy and efficiency of the subjective ride comfort assessment procedures. All stimuli were reconstructed on the DSTF platform, with *Alternative 10* repeated as the *reference signal* in each trial.

This process eliminates the characteristics of the seat as **all** vibration signals are reconstructed **identically** on the **platform** and are isolated in the same way



by the seat. The subjective point of equivalence is thus expected to be at a **JND level of 10**. The best, tested procedure would be the one that converges most accurately to a JND level of 10, with the greatest speed (least trials) and least frustration to the subject (least paired comparisons where the *alternative* is close to the *reference*).

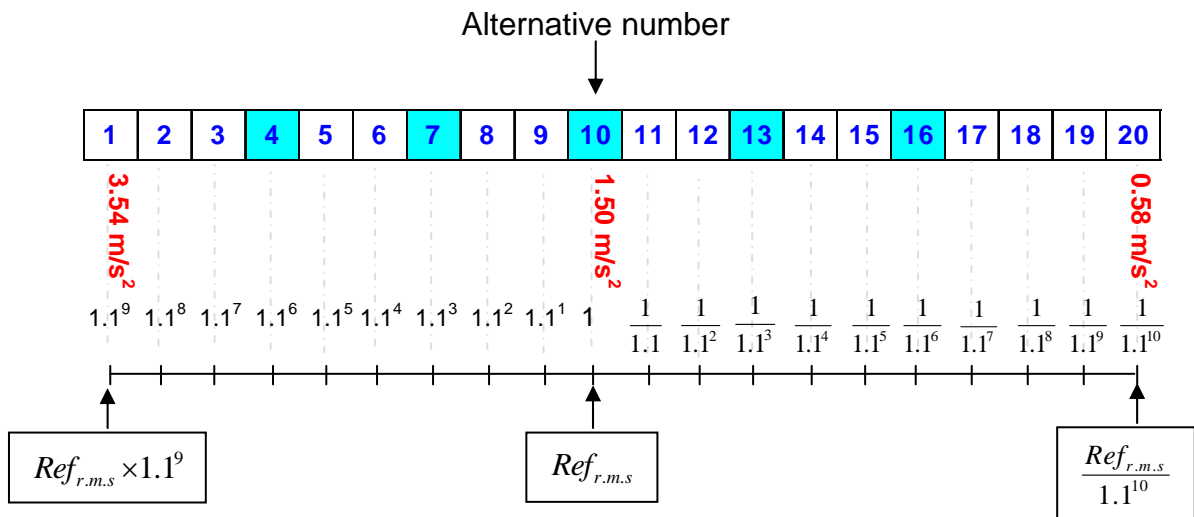


Figure 4.4 Diagram of stimuli scaling

#### 4.2.2 Tested procedures

Nine subjects (discussed in Chapter 3) participated in the comparison of three subjective dynamic seat comfort test procedures:

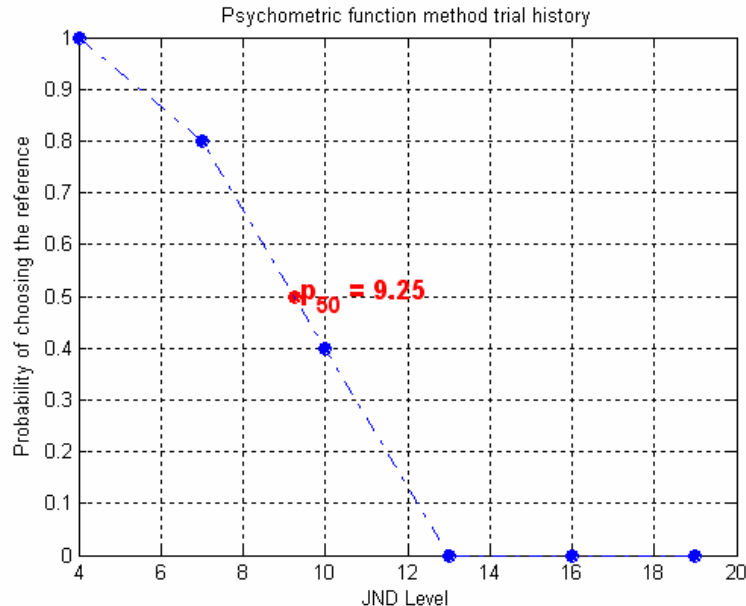
- i.) The psychometric function method of constants
- ii.) Two-track, interleaved Levitt procedure
- iii.) 2-up-1-down, two-track interleaved, Levitt procedure.

All test subjects were *untrained* at the start of the testing procedure. The procedures were tested in an unbiased, random order in an attempt to minimise the effect of increasing subject expertise at detecting the differences in vibration.

#### 4.2.2.1 The psychometric function method of constants

The **psychometric function method of constants** consisted of pooled data at **4, 7, 10, 13 and 16 JNDs** (3 JNDs apart). The *alternative stimuli* levels for the psychometric method are highlighted in cyan in Figure 4.4. Each pooled stimulus pair was repeated for **five trials**, with an **additional five trials** if the probability of choosing the *reference vibration* was between 10% and 90%. In other words, if **the subject had one choice that was different from the other choices** of comfort in the pooled data set, this would result in a further five trials at the current stimulus level (*this increases the data resolution to at least 10%*).

The trials were ordered, starting with *Alternative 4, 16, 7, 13 and 10*. Thus, the **easiest trial combinations were played first** (with a difference of **6 JNDs** between the first two data sets, then **3 JNDs** and then at a level which is identical, with both stimuli at 10 JNDs). This gives the subject time to adapt to the procedure, as the initial choices are less challenging (easy to tell).



**Figure 4.5 A psychometric function probability plot**

Literature [*Pielemeier et al., 1999*] recommends that ten paired comparison trials be reconstructed at each vibration level, with an additional ten trials at vibration levels where the probability of choosing the *reference* is not absolute.

A further ten trials is added at the level where the probability of choosing the *reference* is closest to 50%. In this study, **only half of the recommended trials were performed**. Reasons for this include the time consuming nature of the psychometric test procedure and an indication of more efficient and accurate procedures by literature.

The results attained in this study could have a better data resolution and only contain a projection of possible trials if the full-length procedure was used. This approach implies that the subject experienced identical vibrations for the last 10 trials of the test (as the *reference* vibration is the same as *Alternative 10*). Thus, the subject guessed for the last ten trials, which is not ideal. This scenario would not occur under normal circumstances, where an *alternative stimulus* is compared to a *reference vibration* that is reconstructed in such a way that it is not identical on the platform (as in this case), but identical on any test seat.

#### **4.2.2.2 Two-track, interleaved Levitt procedures**

The potential of a **two-track, interleaved 1-up-1-down** Levitt procedure and a **two-track, interleaved 2-up-1-down** Levitt procedure were investigated for subjective dynamic seat comfort assessment. The convergence criterion for both Levitt procedures was **ten reversals** [*direct correspondence with Dr. WJ Pielemeier (Ford Research Laboratory, Dearborn, Michigan)*] or a maximum of **50 trials** for each track (or sequence). Both procedures consisted of **two interleaved tracks**, with *Alternative 10* repeated as the *reference vibration* in each stimulus pair.

The “A sequence” started from the **rougher** stimulus, randomly chosen between the levels of **1 JND to 3 JNDs**. The first trial of the “B sequence” contained *Alternative 10* and a random choice of **Alternatives 18 to 20**.

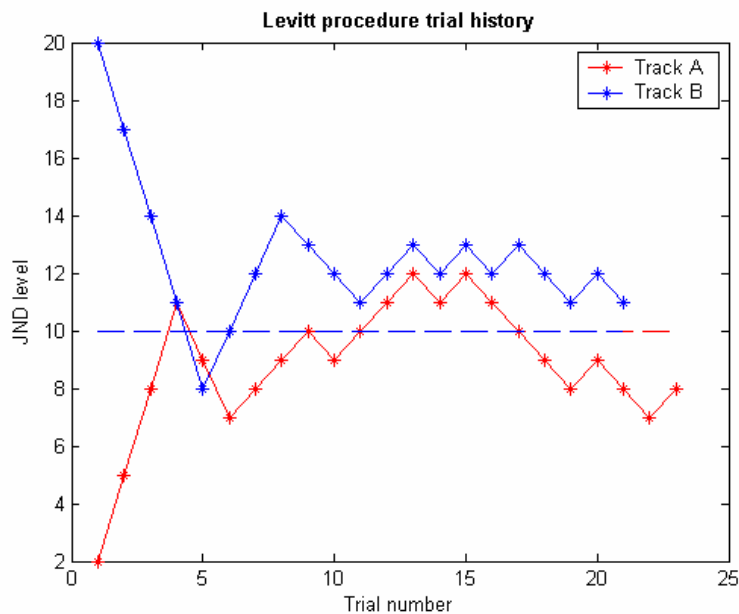
The problem with a one-track Levitt procedure is that a small bias occurs in the subject response sequence. If the initial step size were 6, all the “correct” responses would have a step size of 6, 4, 2 and 1, whereas “incorrect” responses would have a step size of 5, 3 and 1. The effect of this is unknown,

but can be disguised by using a two-track, interleaved Levitt procedure. Thus, the idea behind a two-track, interleaved approach is to eliminate the bias between the positive and negative responses of the subject.

*i.) Two-track, interleaved Levitt procedure*

A normal Levitt procedure with **two interleaved tracks** (or sequences), converging from different sides of *Alternative 10*, was compared with the 2-up-1-down procedure. The **initial step size** was **3 JNDs**, and decreased by **1 JND** after each reversal (Figure 4.6).

The method of analysis was tested by comparing procedure accuracy when all reversals vs. the last six reversals were averaged to find the subjective level of equivalence for each track. [*Averaging the last six reversals was recommended in direct correspondence with Dr. WJ Pielemeier*]. The equivalence levels of the two Levitt tracks were averaged to find the subjective level of equivalence for the procedure.



**Figure 4.6 A two-track, interleaved Levitt procedure**

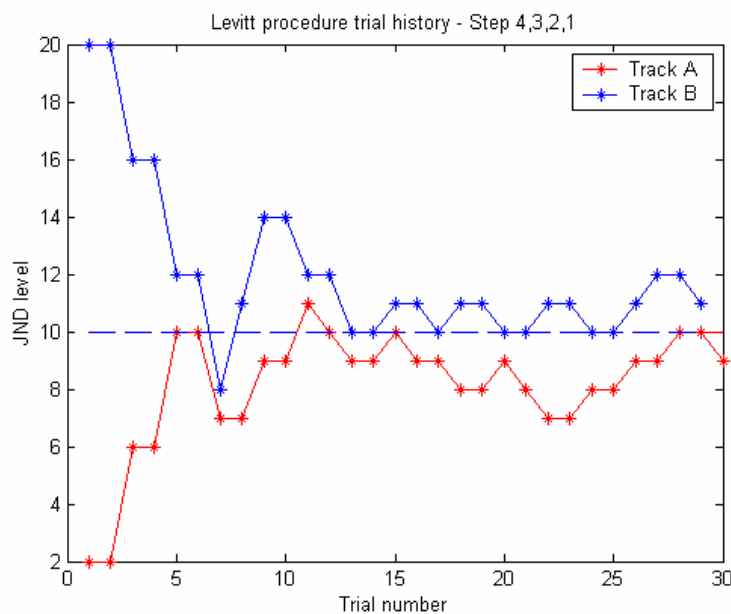
The advantage of the two-track Levitt procedure is that it is more economic as it only takes one trial to order a reversal and the reaction bias is eliminated, by making the two tracks converge from different sides of the *reference*. The most

data is gathered about the point on the psychometric curve in which we are interested.

The most important difference between the 2-up-1-down Levitt and the two-track Levitt procedure is that the 2-up-1-down procedure estimates two points on the psychometric curve (79% and 21%), whereas both tracks of the two-track Levitt estimate the subjective point of equivalence (50%). Standard, interleaved Levitt procedures have been used with success in subjective equivalence testing [Pielemeier et al., 1999 and Bellmann et al., 2000], but not for the testing of dynamic seat comfort.

*ii.) 2-up-1-down, two-track interleaved, Levitt procedure*

It was previously stated that the 2-up-1-down Levitt procedure has the advantage that it requires less observations close to the subjective equivalence level, since the observations focus on the 21% and 79% points on the psychometric curve. The fact that a direction change takes two trials in one of the directions of each interleaved track significantly increases the number of trials to convergence.



**Figure 4.7 A 2-up-1-down, two-track interleaved, Levitt procedure with an initial step size of 4 JNDs**

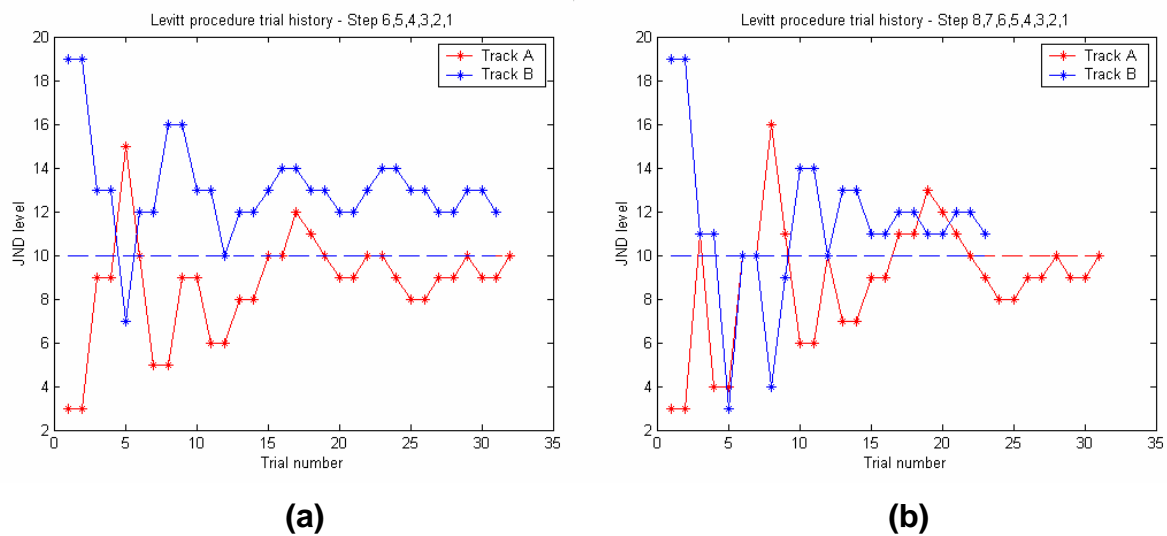
An **initial step size of 4 JNDs** was chosen, which was decreased by **1 JND** after each reversal (Figure 4.7). The reasoning behind this is that 10 reversals are required for a track to converge and the step size will reach **1 JND** after **4 reversals**. This gives a good resolution when the last 6 reversals are averaged, to find the 21% or 79% probability level.

iii.) *Further testing of the 2-up-1-down, two-track interleaved, Levitt procedure*

As literature seemed to indicate that the 2-up-1-down Levitt procedure is the most promising subjective paired comparison procedure and this was confirmed by our own tests, some further work was done to refine the choice of step size.

It appeared that the procedure wasted trials in initially getting to the stimulus region, which is close to the *reference* level with an initial step size of 4 JNDs. This could possibly be improved by *increasing* the initial step size, which in turn implies that some procedure accuracy is sacrificed because of a coarser resolution on the last six track reversals.

The procedure was additionally tested with initial step sizes of 6 and 8 JNDs, decreasing with 1 JND after each reversal.



**Figure 4.8 2-up-1-down, two-track interleaved, Levitt procedures with initial step sizes of (a) 6 JNDs (b) 8 JNDs**

### **4.2.3 Criteria for deciding on the best test procedure**

The decision of the subjective dynamic ride comfort test procedure was based on the number of trials to convergence, procedure accuracy, inter-subject variance of the subjective equivalence level estimate, and the number of trials close or equal to the *reference* stimulus level.

#### **4.2.3.1 Number of trials**

This is important for two reasons: As each trial lasts about 30 s, the more trials, the longer the test, and the more time consuming it would be for the operator and the test subject. In addition, experiments are more “costly” in the event of a retesting situation. The other problem with long tests is the subjects’ concentration span. Paired comparison tests become laborious and straining. The subject’s attention wavers, which is frustrating to both the subject and the operator. In addition, data gathered under such conditions give unreliable results.

#### **4.2.3.2 Accuracy of convergence level estimates**

The design of the subjective procedure tests has the advantage that the convergence level for the paired comparison procedures is known. The smallest difference in vibration magnitude that a person can sense is 1 JND. A procedure that is less accurate than this implies that there is a perceivable difference between the *reference* vibration and the convergence value, which is undesirable.

#### **4.2.3.3 Variance of convergence level estimates**

The variance of the subject convergence levels is an indication of the robustness of the test procedure. The bigger the variance, the wider the range of points of subjective equivalence predicted by the procedure. The smaller the

variance, the more resolute the procedure is at predicting the subjective level of equivalence.

#### 4.2.3.4 Number of trials where the alternative stimulus is close to or equal to the reference signal

On each test trial, two stimuli are reconstructed on the platform. The bigger the difference between the *reference* stimulus and the *alternative* stimulus, the easier it is for the subject to decide on the most comfortable stimulus. Trials close or equal to the *reference* are harder to tell apart. The subject has to concentrate harder and finds the test more exhausting. Subjects also get frustrated when they feel they are guessing, as their decisions do not seem to bare significance. However, there is a trade-off, in that many trials close to the *reference* point collect more data close the point of interest.

### 4.3 Conclusion of subjective procedure test results

Table 4.1 Subjective procedure test results

Criteria	Psychometric function method of constants	2-up-1-down, two-track interleaved, Levitt procedures			
		Initial step 3 JNDs 1-up-1-down	Initial step 4 JNDs	Initial step 6 JNDs	Initial step 8 JNDs
No. of trials	91	45	59	55	53
Error (%)	0.8	0.6	4.4	2.9	0.2
Variance (%)	7.1	8.2	6.4	7.4	6.1
Trials equal	30	9	9	9	9
Trials close	30	25	25	25	24

Table 4.1 shows a summary of the subjective test results. The score of the procedure that performed the best in each criterion is highlighted in yellow. The 2-up-1-down, two-track interleaved, Levitt procedure with an initial step size of 8 JNDs is chosen as the subjective seat comfort assessment procedure. Of the methods tested, this method is the second most economic and most accurate in predicting the subjective level of equivalence, with the smallest variance and the least trials close to the *reference stimulus* level.



An initial step size of 8 JNDs will be used, and ten reversals or a maximum of 50 trials will be required for a test track to converge. The average of the last six reversals will be taken to determine the relevant points on the psychometric curve.

All subjects participated in at least 240 trials of evaluating the most comfortable stimulus in a paired-comparison, forced-choice procedure was evaluated. Pielemeier et al. [1999] suggests that all subjects undergo a training period of 240 trials before their learning curve stabilizes. The subjects are thus considered trained for participation in subjective ride comfort tests. Subject 1 – 6 participated in the tests that are discussed subsequently.

Only a limited amount of procedures and procedure parameters were tested. The evaluation of these subjective dynamic seat comfort assessment procedures are by no means conclusive, but merely suffice to prove that the implemented procedure is accurate and effective in the determination of the subjective point of equivalence.



# The dynamic seat comfort assessment procedure

Chapter 5 discusses the dynamic seat comfort assessment procedure. The objective of these tests was to determine the correlation between subjective and objective dynamic seat comfort metrics. The steps of the test procedure are outlined in Appendix B.

Subjective ride comfort was measured using the virtual seat method, according to a two-track interleaved, Levitt procedure with a 2-up-1-down step criterion and an initial step size of 8 JNDs. Subjects completed the Kolich subjective ride comfort assessment survey as an additional subjective measure. SEAT value was used as the objective dynamic seat comfort metric and was calculated from the relevantly weighted, seat- and platform vibration measurements for each seat and subject.

The extent of the correlation between the subjective and objective dynamic seat comfort metrics indicated the accuracy of using SEAT values for the prediction of subjective dynamic seat comfort. The steps of the dynamic seat comfort assessment procedure are discussed and motivated in this chapter.

## ***5.1 Subject preparation***

The subjects were briefed on the purpose and method of testing, after which they all signed an informed document of consent. They were informed that they could terminate the test procedure at any time. The subjects' exposure to mechanical vibration was recorded throughout the dynamic seat comfort

assessment procedure. Abnormalities in the test conditions were noted and reported.

Subjects were instructed not to wear unusually thick clothing and to empty their pockets as vibrating items could affect vibration measurement. They were not allowed to alter their seat positions, as the seats were pre-positioned, using a consistent SIP location for the specific test subject and seat (Section 3.5.1). The subjects were instructed to sit in a relaxed, upright position and to place their heels at the intersection of the sloped side of the footrest with the footplate. Subjects were seated with their legs in a normal sitting position and with their thighs supported by the seat top. Their hands were placed in their laps, with one hand on each thigh. A white noise signal (at 80 dBA) [Mansfield, 2001] was played through a headset, worn by the subjects. This measure was taken to eliminate the possible effects of rig noise from subjective seat comfort judgements.

## ***5.2 Reference signal and alternative stimuli signals***

The virtual seat method (Section 2.5.2.2.1.1) was implemented for the assessment of the subjective dynamic seat comfort of the seven test seats. This required the reconstruction of vibration for paired comparison trials. The trials were presented to the subjects according to a 2-up-1-down, two-track interleaved, Levitt procedure (as concluded in Section 4.3). Each trial consisted of the *reference signal*, and an *alternative stimulus*. The *reference signal* (Section 3.6.5) remained identical on the test seat top and was repeated during each trial of the paired comparison test. The *alternative stimulus* (Section 3.6.6) was reconstructed identically on the platform, but was scaled in magnitude for different trials.

Paired comparison data trials were stored in terms of **acceleration** on the **DSTF platform**. Each trial comprised of two data blocks in random order, of which one was the *reference signal*, and the other an *alternative stimulus*. The

input displacement voltage was estimated from the FRF between the **platform acceleration** and **input displacement** at the start of each trial. The *alternative stimuli* were already expressed in terms of platform acceleration.

### **5.2.1 Reconstruction of the reference signal**

The *reference signal* was reconstructed on the **seat top**, for each subject on each test seat. The input voltage for reconstructing the *reference vibration* was estimated by using the **frequency response function** between the **seat top acceleration** and the **voltage input displacement** (at the *reference* vibration level) for the specific seat-occupant combination.

The platform was displaced with the estimated input voltage. The system response was measured on the seat surface and at the centre of the shaker platform. An error was calculated between the actual response on the seat surface and the desired response in the **frequency** and **time domain**. This error was limited to a maximum of 10% of the *reference* vibration as this represents one JND (which implies a perceptible difference in vibration to the subject). If the response error was smaller than 10%, the recorded **platform vibration** (which resulted in the *reference* vibration on the seat top) was saved and used to construct the input files for the 2-up-1-down paired comparison test.

If the response error was greater than 10%, an **input error** was calculated. This response error was expressed in the frequency domain. An input error was determined through the **frequency response function** between the **seat top vertical acceleration** and **input displacement command signal**. Note that the *reference signal* comprised of a single block of data. Therefore, the FFT of the response error is NOT a result of averaging the frequency content of several blocks. On this basis, the estimation of the input error from the FFT of the response error is justified. The input error was added to the estimated input displacement. The process was iterated until the response error is smaller than 10%. Failure to achieve this resulted in the termination of the subjective ride comfort test.

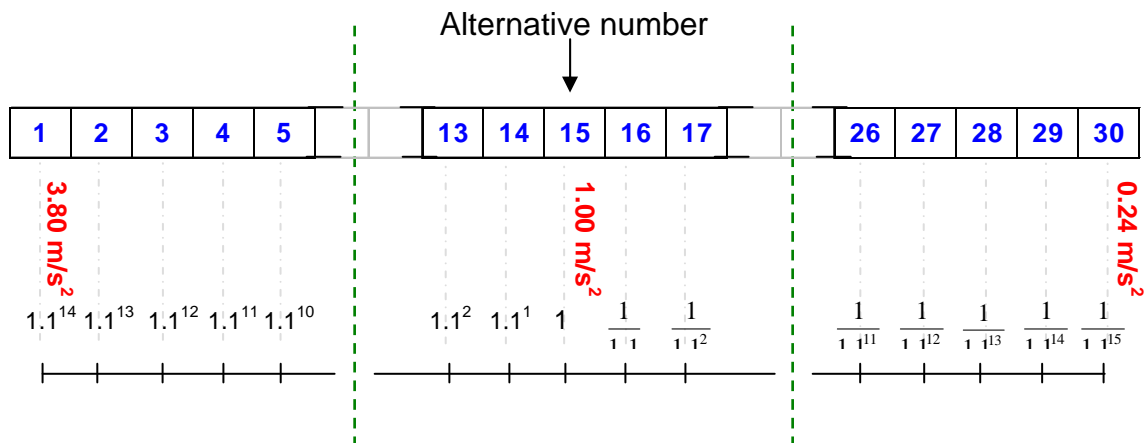
### 5.2.2 Scaling the alternative stimuli

The *road vibration recording* (Section 3.6.4) was scaled to both sides (larger and smaller) with a factor of 1.1, resulting in a series of vibrations that were 1 JND apart (Figure 5.1).

There were 30 *scaled, alternative vibrations* within the safe vibration and actuator limits. The r.m.s. values of the unweighted, filtered vibrations ranged from 0.24 m/s<sup>2</sup> (*Alternative 30*) to 3.80 m/s<sup>2</sup> (*Alternative 1*). *Alternative 15* (the middle *alternative*) had an r.m.s. value of 1.00 m/s<sup>2</sup>, and the original *road data recording* was equal to *Alternative 11*.

This step was completed once, prior to the first subjective ride comfort test, as the *alternative stimuli* remain identical on the platform throughout the entire test series.

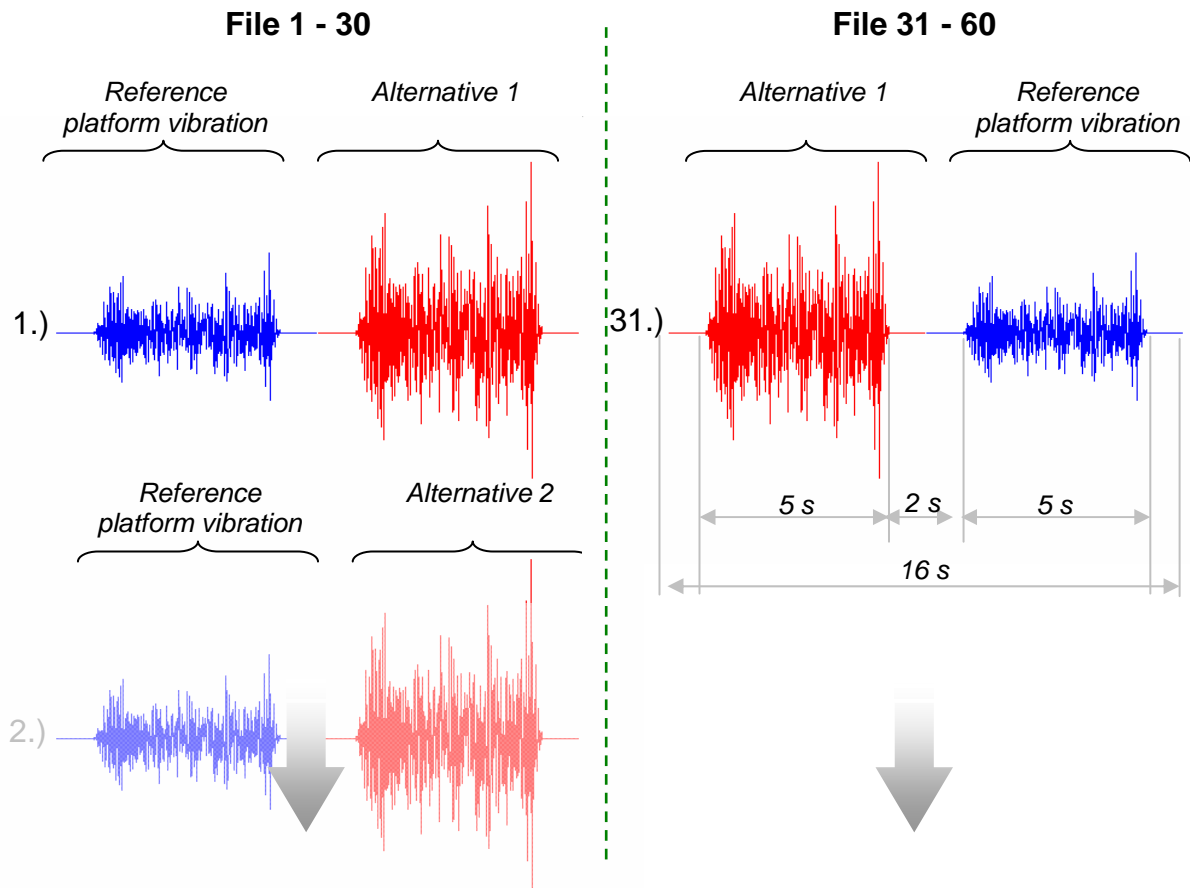
### 5.2.3 Reference and alternative signal files



**Figure 5.1** Scaling of the *alternative stimuli* for the 2-up-1-down, Levitt subjective dynamic seat comfort assessment procedure

There were **60 platform vibration files** that included all possible trials within safe acceleration and displacement limits of the actuator. The files were created for each subject and test seat as the **platform vibration** that produced the

reference signal on the seat top differed for each test. Note that the **input displacement command signal** for the alternative stimuli **varied with each test** as the FRF between the platform acceleration and input displacement command signal was different for each subject-seat combination.



**Figure 5.2 Input file structures for the 2-up-1-down, Levitt subjective dynamic seat comfort assessment procedure**

Each file comprised of two blocks (8 s each) of acceleration data, one of which was the platform acceleration that produced the reference vibration on the seat, and the other, one of the 30 scaled vibration alternatives on the shaker platform. **Two** sets of files were created as the sequence of vibration playback was randomised.

Thirty files comprised of the reference platform acceleration in the first data block, followed by each of the alternative stimuli on the platform in the second data block. The second set of 30 files comprised of exactly the same data, but

with the stimuli in reverse order (first the alternative, then the reference platform acceleration). Figure 5.2 shows a diagram of the file structure.

## **5.3 Subjective dynamic seat comfort assessment**

### **5.3.1 A 2-up-1-down, two-track interleaved, Levitt procedure**

The *reference signal* was played back-to-back with the *vibration alternatives* in an interleaved fashion (using a 2-up-1-down, two-track interleaved, Levitt procedure with an initial step size of 8 JNDs).

Each pair of stimuli was followed by a time slot, in which the subject was forced to choose which stimulus was **preferred** in terms of **comfort**. If the *reference stimulus* was chosen as the **most comfortable**, a “correct” response was recorded. If the *alternative stimulus* was chosen as the **most comfortable**, an “incorrect” response was noted.

The magnitude of the *alternative* test stimulus was adjusted according to the 2-up-1-down transformed response. The subject’s preferred choice’ as well as the trial and *alternative* level’ was recorded for each trial. The previous steps were iterated until both sequences of the interleaved procedure converged (ten reversals for each track or a maximum of 50 trials). The procedure trial history was saved (stimuli order {*reference* then *alternative* or vice versa}, *alternative* levels, step size, subject choice and convergence levels).

### **5.3.2 Completing a reduced version of the Kolich survey**

The virtual seat method resulted in a subjective comparison of seat comfort **relative to the reference seat**. When this comparison is obtained, one might ask: “*What makes a good seat?*” For this purpose, the evaluation of Kolich’s ride comfort questionnaire (Section 2.5.1.2) was included as an additional subjective measure during the test procedure.

Items E, F and J (Table 2.1) were removed as they require the evaluation of seat response to lateral vibration. This resulted in a reduced version of Kolich’s survey that included only parameters that were relevant to vertical seat vibration. The items included in the survey also bared relevance to the locations where acceleration was measured during the test procedure.

This enabled an investigation into the correlation between the subjective data of the Kolich questionnaire and objective dynamic seat comfort assessment. As the questionnaire addresses specific aspects of seat design, this could lead to characterising “*What makes a good seat?*” for the specific vibration exposure of the *reference signal*.

**Table 5.1 A reduced version of Kolich’s automobile seat comfort survey**

<i>Item</i>		-3	-2	-1	<i>Just right</i>	1	2	3	
<b><i>Seatback</i></b>									
A. Amount of lumbar support	too little	<input type="checkbox"/>	<input type="checkbox"/>	<input type="checkbox"/>	<input type="checkbox"/>	<input type="checkbox"/>	<input type="checkbox"/>	<input type="checkbox"/>	too much
B. Lumbar comfort	uncomfortable	<input type="checkbox"/>	<input type="checkbox"/>	<input type="checkbox"/>	<input type="checkbox"/>	<input type="checkbox"/>	<input type="checkbox"/>	<input type="checkbox"/>	
C. Amount of mid-back support	too little	<input type="checkbox"/>	<input type="checkbox"/>	<input type="checkbox"/>	<input type="checkbox"/>	<input type="checkbox"/>	<input type="checkbox"/>	<input type="checkbox"/>	too much
D. Mid-back comfort	uncomfortable	<input type="checkbox"/>	<input type="checkbox"/>	<input type="checkbox"/>	<input type="checkbox"/>	<input type="checkbox"/>	<input type="checkbox"/>	<input type="checkbox"/>	
G. Seatback feel/firmness	too soft	<input type="checkbox"/>	<input type="checkbox"/>	<input type="checkbox"/>	<input type="checkbox"/>	<input type="checkbox"/>	<input type="checkbox"/>	<input type="checkbox"/>	too firm
<b><i>Cushion</i></b>									
H. Ischial/buttocks comfort	uncomfortable	<input type="checkbox"/>	<input type="checkbox"/>	<input type="checkbox"/>	<input type="checkbox"/>	<input type="checkbox"/>	<input type="checkbox"/>	<input type="checkbox"/>	
I. Thigh comfort	uncomfortable	<input type="checkbox"/>	<input type="checkbox"/>	<input type="checkbox"/>	<input type="checkbox"/>	<input type="checkbox"/>	<input type="checkbox"/>	<input type="checkbox"/>	

The 1.5 m/s<sup>2</sup> *road vibration recording* (Section 3.6.4) was reconstructed on the platform (one block of data with a vibration duration of 5 s). Subjects were handed, and allowed to read through the reduced version of, Kolich’s seat comfort questionnaire. The subjects were again exposed to the *road vibration recording* and subsequently asked to complete the reduced version of Kolich’s ride comfort survey (Table 5.1).

### **5.4 Objective data for SEAT value calculation**

The *road vibration recording* (duration 5 s) was scaled to produce road vibration signals with unweighted r.m.s. values of 1 m/s<sup>2</sup>, 1.5 m/s<sup>2</sup> and 2 m/s<sup>2</sup>. These *road vibration recordings* were reconstructed on the DSTF platform (as



described in Section 3.6.6) by estimation of the input command signal from the FRF between the **platform vertical acceleration** and **input displacement command signal**.

The vibrations on the platform, seat top, perpendicular- and in-plane seatback were recorded at each mentioned vibration magnitude. The PSDs of the measured seat and platform vibrations were weighed with the relevant weightings (Section 2.2.2) to calculate SEAT values with the direct method (using Equation 2.2).

The seat transmissibility measurements (Section 3.6.3) were used to estimate the actual seat vibration from platform vibration measurements. This data was used to calculate an additional set of SEAT values with Equation 2.3. The SEAT values are reported in Table 6.1 as the objective metric for the assessment of dynamic seat comfort in this study.

## ***5.5 Test procedure conclusions***

The dynamic seat comfort test procedure applied the principles of the literature survey and our own subjective paired comparison tests to obtain subjective and objective dynamic seat comfort assessments. The subjective ratings were obtained from the subjective levels of equivalence determined with a 2-up-1-down, two-track-interleaved, Levitt procedure. SEAT values on the seat top and perpendicular- and in-plane seatback serve as the objective dynamic seat comfort assessment. The results and correlation of these assessments are subsequently summarized in Chapter 6.



# Discussion of results

Table 6.1 summarises the dynamic seat comfort results, averaged over the six subjects, for each of the seven test seats. SEAT values were calculated, using actual platform- and seat vibration measurements. An additional set of SEAT values was computed by estimating the vibration on the seat with the relevant seat transmissibility function.

The subjective ratings are the subjective levels of equivalence, determined during a 2-up-1-down, two-track interleaved, Levitt procedure. Note that, for the purposes of this study, a seat that converges to a **low JND level** is interpreted as a subjectively **more comfortable** seat. For such a seat, a greater vibration input is required at the seat track before the subject experiences the vibration to be equal to the *reference vibration* on the seat top. This implies that the seat offers greater vibration isolation, which increases dynamic seat comfort.

**Table 6.1 Averaged dynamic seat comfort results**

Seat	Vehicle	Averaged SEAT values measured			Averaged SEAT values estimated			Subjective rating
		Seat top	Seatback in-plane	Seatback perpendicular	Seat top	Seatback in-plane	Seatback perpendicular	
A	Luxury sedan	79	112	60	78	95	63	12.2
B	Economy sedan	74	108	70	75	97	66	11.6
C	Air-suspension truck	56	107	42	42	92	44	7.4
D	Rigid wood	90	112	48	91	106	48	13.8
E	Small pick-up	88	111	65	87	102	65	12.5
F	Economy sedan	73	112	53	76	99	54	11.2
G	Double-cab pick-up	69	110	51	71	100	49	10.7

Note that subject 4 and 5 did not complete the dynamic seat comfort test on Seat C. The *reference signal* could not be reconstructed within 10% accuracy on the seat top for these subjects and the tests were terminated.

## 6.1 Subjective dynamic seat comfort results

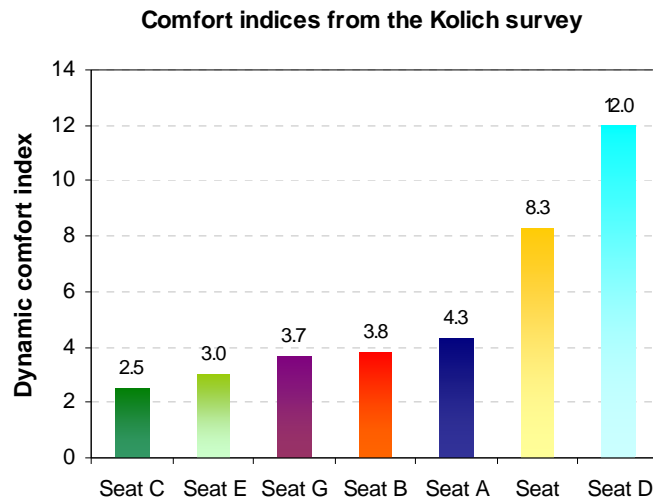
### 6.1.1 Kolich survey results

A reduced version of Kolich's survey [Kolich, 1999] was used to determine subjective dynamic comfort indices for the test seats (Section 5.3.2). The **lower** the index, the **better** the dynamic comfort of the seat. The individual dynamic comfort indices of the test seats are listed in Table 6.2. Subject 1 rated Seat C as the perfect seat, whereas Subject 2 experienced ultimate ride comfort on Seat E. Subject 1 gave the worst comfort rating for the ride comfort experience of Seat D.

**Table 6.2 Overall dynamic comfort indices from the reduced Kolich survey**

<i>Subject No.</i>	<i>Seat A</i>	<i>Seat B</i>	<i>Seat C</i>	<i>Seat D</i>	<i>Seat E</i>	<i>Seat F</i>	<i>Seat G</i>
1	3.0	5.0	0.0	15.0	2.0	13.0	2.0
2	5.0	2.0	6.0	12.0	0.0	5.0	5.0
3	5.0	5.0	2.0	13.0	8.0	11.0	3.0
4	6.0	4.0	2.0	12.0	4.0	7.0	9.0
5	2.0	1.0	2.0	10.0	2.0	9.0	2.0
6	5.0	6.0	3.0	10.0	2.0	5.0	1.0
<b>Stdev</b>	<b>1.5</b>	<b>1.9</b>	<b>2.0</b>	<b>1.9</b>	<b>2.8</b>	<b>3.3</b>	<b>2.9</b>
<b>Avg</b>	<b>4.3</b>	<b>3.8</b>	<b>2.5</b>	<b>12.0</b>	<b>3.0</b>	<b>8.3</b>	<b>3.7</b>

Averaged subjective ratings (Figure 6.1) from the Kolich survey indicate that Seat C offers the best dynamic seat comfort when the *road vibration recording* is reconstructed on the platform. Seat G and B were rated similarly. The rigid seat is by far the most uncomfortable, followed by Seat F, which was also rated much worse than the other test seats. Subject opinions varied the most on the dynamic seat comfort of Seat F.



**Figure 6.1 Averaged subjective ratings from the Kolich survey**

### ***6.1.2 Two-up-1-down, two-track interleaved, Levitt procedure results***

Table 6.3 summarises the individual and averaged subjective ride comfort ratings and the standard deviation for each seat. The Levitt procedure trial histories are plotted in Appendix C. According to individual subjective ride comfort ratings, Subject 6 experienced the most comfortable ride on Seat C. Subject 2 and Subject 5 rated the most uncomfortable ride on Seat D.

The individual ride comfort rating of Seat C shows the greatest variance and that of Seat D, the least. This indicates that the test subjects had the greatest consensus on rating the dynamic seat comfort of Seat D, probably due to the seat's linear behaviour. The greater variance in the subjective rating of Seat C can be attributed to the smaller sample size of four subjects or to the fact that the seat offers significantly different ride comfort to subjects of different weight.

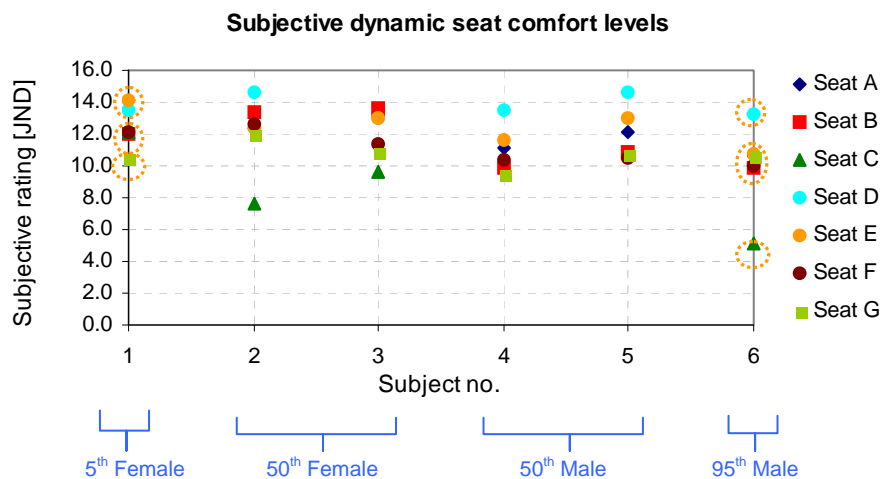
Figure 6.2 shows the individual subjective ride comfort ratings determined from paired comparison testing, plotted for each subject and seat. This illustrates the ability of subjects to discern vibration levels and to relate them in terms of ride comfort.

**Table 6.3 Subjective ride comfort ratings**

Subject no.	Seat A	Seat B	Seat C	Seat D	Seat E	Seat F	Seat G
1	14.1	12.0	12.2	13.5	14.2	12.1	10.5
2	12.3	13.4	7.7	14.7	12.4	12.6	12.0
3	13.2	13.6	9.7	13.0	13.0	11.4	10.9
4	11.2	9.8	**	13.5	11.7	10.4	9.5
5	12.1	10.9	**	14.7	13.0	10.5	10.8
6	10.6	9.9	5.2	13.3	10.8	10.0	10.6
<b>Stdev</b>	<b>1.3</b>	<b>1.7</b>	<b>3.0</b>	<b>0.7</b>	<b>1.2</b>	<b>1.0</b>	<b>0.8</b>
<b>Avg</b>	<b>12.2</b>	<b>11.6</b>	<b>7.4</b>	<b>13.8</b>	<b>12.5</b>	<b>11.2</b>	<b>10.7</b>

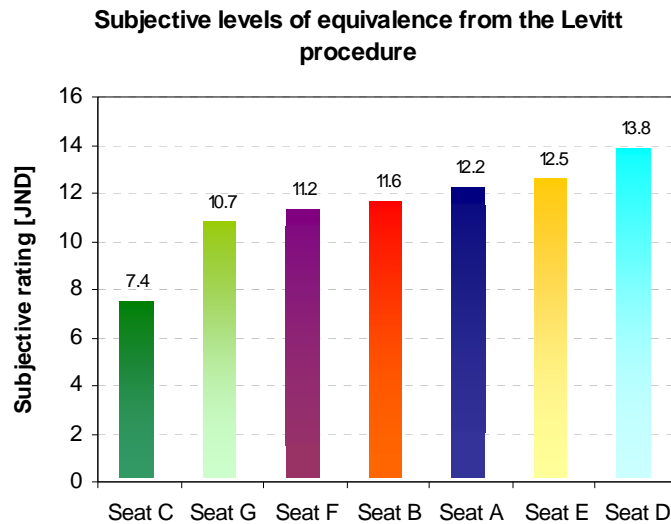
\*\* The reference signal could not be reconstructed within 10% accuracy

Subject 1 judged most of the tested seats to be on virtually the same level. All her subjective dynamic comfort ratings are in the range of **10 – 14 JNDs**. Subject 6 distinguishes dynamic seat comfort in three groups: Seat C is the most comfortable, Seats A, B, E, F & G (the car seats) offer moderate comfort and Seat D offers the least dynamic comfort. His observations are in the range between **5 - 13 JNDs**. Most subjects perceived Seat D to be distinctly less comfortable than the other test seats.



**Figure 6.2 Subjective comfort ratings from paired comparison tests**

Figure 6.3 shows the **average** subjective seat comfort ratings. The air-suspension seat (Seat C) is judged as dynamically the most comfortable. The double-cab pick-up seat (Seat G) is rated the most comfortable car seat for the particular road tested. The rigid seat (Seat D) is rated as the seat with the lowest ride comfort.



**Figure 6.3 Subjective dynamic seat comfort ranking**

The difference in the dynamic seat comfort of Seat C (air-suspension seat) and Seat D (rigid seat) is  $13.8 - 7.3 = 6.4$  JNDs, which is a significant perceptual difference in seat vibration. The car seats (Seats A, B, E, F & G) were rated between **10.7** and **12.5** JNDs. The perceived difference in comfort between Seat E and Seat G is **1.8 JNDs**, which is almost two times the smallest perceivable difference in ride comfort. The results indicate that car seats have similar performances in vibration isolation (which is expected, since they are designed for similar applications).

## **6.2 Objective dynamic seat comfort results**

Table 6.4 shows the individual SEAT values for each subject on the seat top of each test seat. The r.m.s. values of acceleration measurements on the platform and seat are listed in Appendix D. The **less** the **SEAT value**, the **greater the dynamic comfort** of the test seat (according to objective evaluation).

The individual SEAT values indicate that Subject 6 experienced the most comfortable ride on Seat C and Subject 2 experienced the most uncomfortable ride on Seat B. The results of Seat C have the greatest

standard deviation, indicating great differences in the vibration measured on the seat top for different seated subjects. This phenomenon can be explained by the non-linear behaviour of an air spring. This argument is supported by the small standard deviation of the dynamic seat comfort sample of Seat D, which is the most linear seat (it has the least non-linear effects caused by seat cushioning).

SEAT values on the in-plane seatback (Table 6.5) do not indicate a varying dynamic seat comfort experience. The values differ by only 5% and range from 97.8% - 102%. This indicates that none of the test seats significantly amplify or isolate vibrations in this direction. The SEAT values of Seat C and Seat A have a variance of more than 10 % in this direction. Both seats amplify the in-plane seatback vibration significantly for the 5<sup>th</sup> percentile female.

**Table 6.4 SEAT values on the seat top**

<b>Subject no.</b>	<b>Seat A</b>	<b>Seat B</b>	<b>Seat C</b>	<b>Seat D</b>	<b>Seat E</b>	<b>Seat F</b>	<b>Seat G</b>
1	109	77	80	86	96	72	75
2	80	76	59	91	112	85	76
3	81	95	54	88	88	81	74
4	69	61	**	96	77	65	65
5	71	71	**	92	81	69	65
6	66	65	31	88	76	68	59
<b>Stdev</b>	<b>16</b>	<b>12</b>	<b>20</b>	<b>4</b>	<b>14</b>	<b>8</b>	<b>7</b>
<b>Avg</b>	<b>79</b>	<b>74</b>	<b>56</b>	<b>90</b>	<b>88</b>	<b>73</b>	<b>69</b>

\*\* The *reference signal* could not be reconstructed within 10% accuracy

All the test seats isolate the occupant from the perpendicular seatback vibration of the *reference signal* (Table 6.6). The air-suspension seat is superior in this direction of instance and isolates the occupant from 44% of the backslap vibration. Seats B, D and E offer better backslap vibration isolation to smaller and lighter individuals, whereas Seat C performs better for taller and heavier subjects. This illustrates that some seats are more suitable for certain individuals than others. Occupants are the most sensitive to vibrations between 0.7 and 8 Hz [ISO 2631-1:1997]. The *reference vibration* contains some energy in this frequency range.

**Table 6.5 SEAT values on the in-plane seatback**

<b>Subject no.</b>	<b>Seat A</b>	<b>Seat B</b>	<b>Seat C</b>	<b>Seat D</b>	<b>Seat E</b>	<b>Seat F</b>	<b>Seat G</b>
1	77	62	60	41	66	57	52
2	46	70	40	32	59	61	53
3	48	49	32	31	39	41	39
4	67	72	**	59	68	62	59
5	60	83	**	60	75	55	60
6	64	85	35	66	79	43	41
<b>Stdev</b>	<b>12</b>	<b>13</b>	<b>13</b>	<b>15</b>	<b>14</b>	<b>9</b>	<b>9</b>
<b>Avg</b>	<b>60</b>	<b>70</b>	<b>42</b>	<b>48</b>	<b>65</b>	<b>53</b>	<b>51</b>

\*\* The reference signal could not be reconstructed within 10% accuracy

**Table 6.6 SEAT values on the perpendicular seatback**

<b>Subject no.</b>	<b>Seat A</b>	<b>Seat B</b>	<b>Seat C</b>	<b>Seat D</b>	<b>Seat E</b>	<b>Seat F</b>	<b>Seat G</b>
1	123	98	115	99	98	103	101
2	101	98	92	102	100	100	100
3	97	98	89	104	100	99	100
4	98	101	**	103	107	103	100
5	93	97	**	105	102	102	100
6	99	101	94	99	98	110	102
<b>Stdev</b>	<b>11</b>	<b>2</b>	<b>12</b>	<b>2</b>	<b>3</b>	<b>4</b>	<b>1</b>
<b>Avg</b>	<b>102</b>	<b>99</b>	<b>98</b>	<b>102</b>	<b>101</b>	<b>103</b>	<b>101</b>

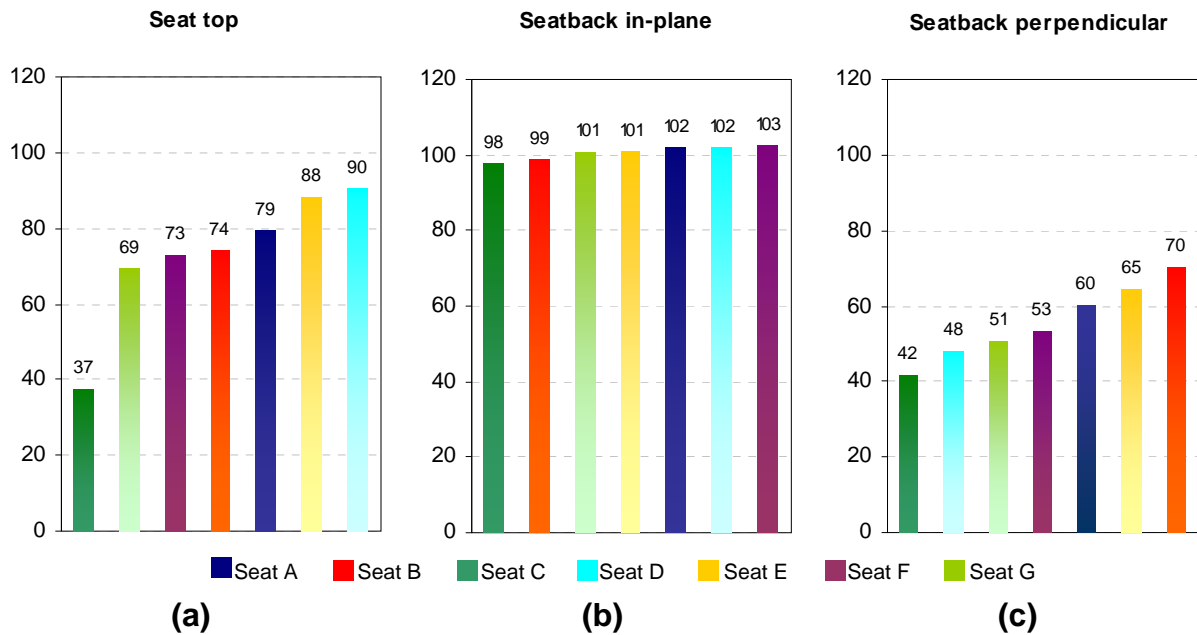
\*\* The reference signal could not be reconstructed within 10% accuracy

Figure 6.4 shows the objective seat comfort ranking of seats according to measured SEAT values from vibrations on the seat top, seatback in-plane and seatback perpendicular directions.

SEAT values on the seat top are grouped into three groups, where Seat C is significantly more comfortable, Seat D and E significantly less comfortable and Seats A, B, F & G, have average comfort. All the seats have SEAT values of less than 100%, which means that all of them offer vibration isolation at the seat top (*for this specific reference signal*). The dynamic comfort ranking of the test seats according to seat top values, agrees with the subjective ride comfort ranking.

The dynamic comfort ranking of the SEAT values on the seatback (perpendicular and in-plane) do not agree with the subjective comfort ranking. The reason could be the different magnitudes of the averaged r.m.s vibration magnitudes at different locations on the seats (Table 6.7).





**Figure 6.4 Objective dynamic seat comfort ranking according to SEAT values on the (a) seat top (b) seatback in-plane and (c) seatback perpendicular**

The weighted vibration magnitudes of the seatback perpendicular and seatback in-plane vibration are respectively in the range of **5** and **17 JNDs** smaller than that experienced on the seat top. The seatback vibrations are, therefore, perceived as much less dominant than the seat top vibration. The test subjects' evaluation of dynamic seat comfort correlates with the most dominant vibration, which is experienced on the seat top.

The SEAT values of the seatback in-plane vibration only vary with 5% between seats and indicate a vibration transmission around unity. According to these values, the comfort ranking does not correlate with subjective comfort ranking. Vibration measured in this direction does not seem to be perceived as influential on dynamic seat comfort. The human sensitivity weighting curves (for in-plane seatback vibration comfort) indicate that  $W_d$  is a maximum between 0.5 – 1.7 Hz [ISO 2631-1:1997]. The *reference signal* contains the rigid-body mode of the vehicle floor pan at these frequencies. The in-plane seatback values reported by Van Niekerk et al. [2002] ranged from 8% - 9% (Section 2.6), whereas the values calculated in this study are 98% - 103%.

The *virtual reference* (Figure 2.9) used by Van Niekerk, contained about ten times less vibration input at the frequencies of 0.5 – 1.7 Hz. The difference in the frequency content of the *reference signals* used in the two studies accounts for the large difference in the reported SEAT values for the in-plane seatback.

**Table 6.7 Averaged r.m.s. vibration values measured on the test seats**

<i>Location</i>	$a_{z\_plat}$ [m/s <sup>2</sup> ]	$a_{zw\_plat}$ [m/s <sup>2</sup> ]
Platform	1.0	*0.7
Seat top	0.8	0.5
Seatback in-plane	0.9	0.1
Seatback perpendicular	0.4	0.3

\* Platform vibration weighted with  $W_k$  as for seat top vibration

### **6.3 Correlation between subjective and objective dynamic seat comfort**

SEAT values on the seat top appear to be the most accurate in predicting subjective dynamic seat comfort. These values are analysed further and discussed in subsequent paragraphs.

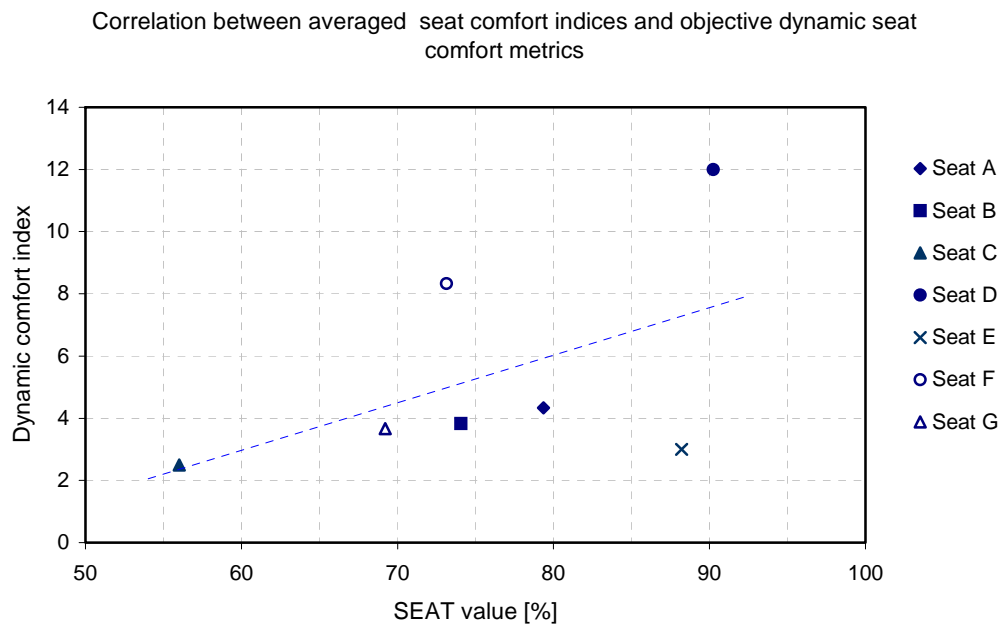
#### **6.3.1 Correlation between SEAT values and data from the Kolich survey**

There is no correlation between SEAT value on the seat top and averaged or individual dynamic comfort indices as determined by the Kolich survey ( $R^2 = 0.26$ ). The averaged comfort indices are plotted against SEAT value on the seat top for each test seat (Figure 6.5).

Possible reasons for the lack of correlation are that static comfort and subject bias towards certain seats are not eliminated. Subjective ratings from this

survey are susceptible to daily variation in subject perception. There is a time lapse of several days between the evaluation of different seats.

The use of the Kolich survey for the prediction of dynamic seat comfort does not appear feasible for only six subjects. It is possible that the quality of subjective results obtained in this manner can be improved by using a larger group of individuals. This method will not be investigated further in this project.



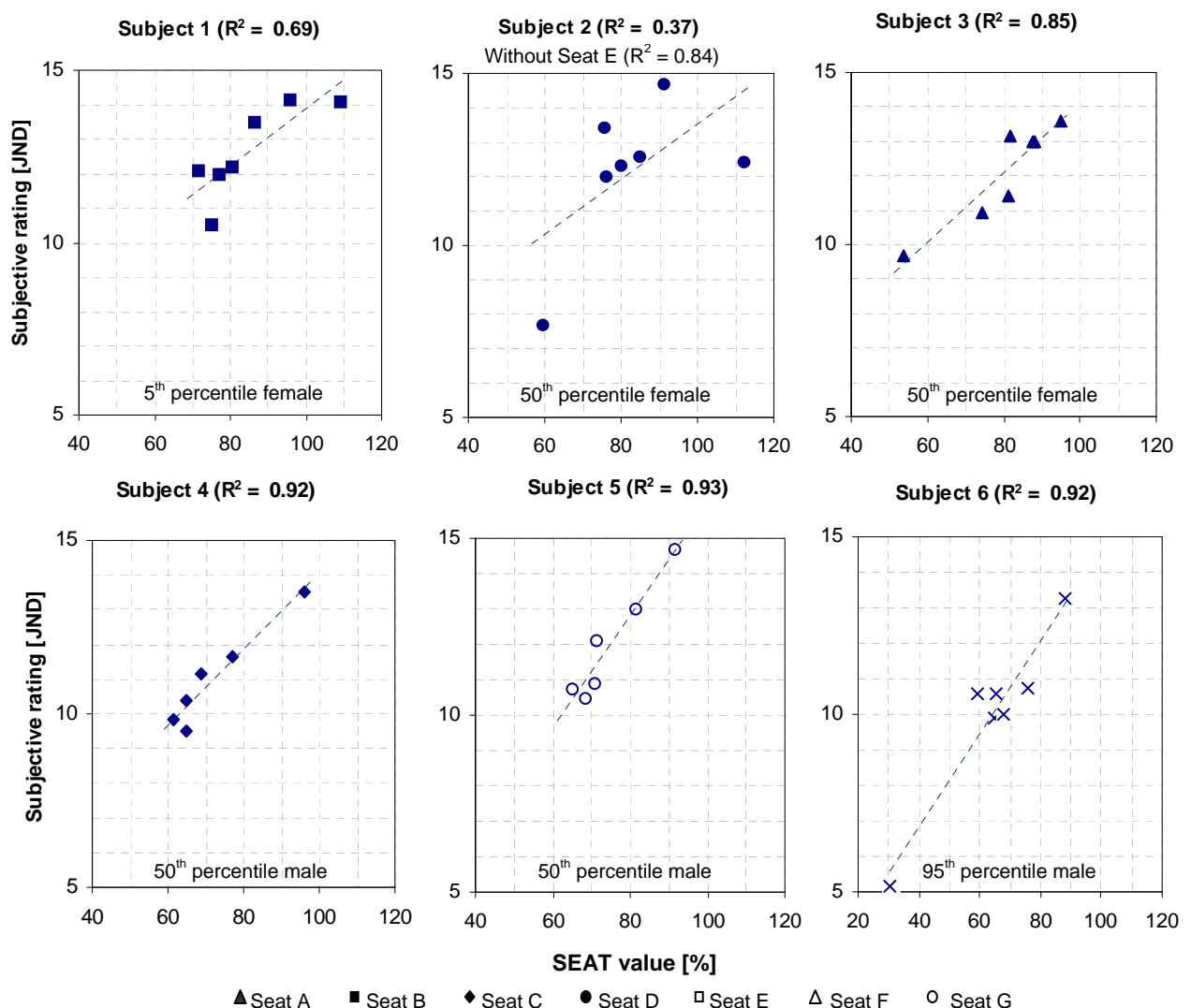
**Figure 6.5 The correlation between dynamic comfort indices determined with the Kolich survey and SEAT value**

### ***6.3.2 Correlation between SEAT values and data from the 2-up-1-down, two-track interleaved, Levitt paired comparison procedure***

Figure 6.6 shows the SEAT values on the seat top plotted against subjective comfort levels for each subject. The correlation between these values shows how much a subject's individual evaluation of dynamic comfort agrees with SEAT values calculated from measurements on the seat. The data of Subjects 3, 4, 5 and 6 indicate an excellent correlation between the individual

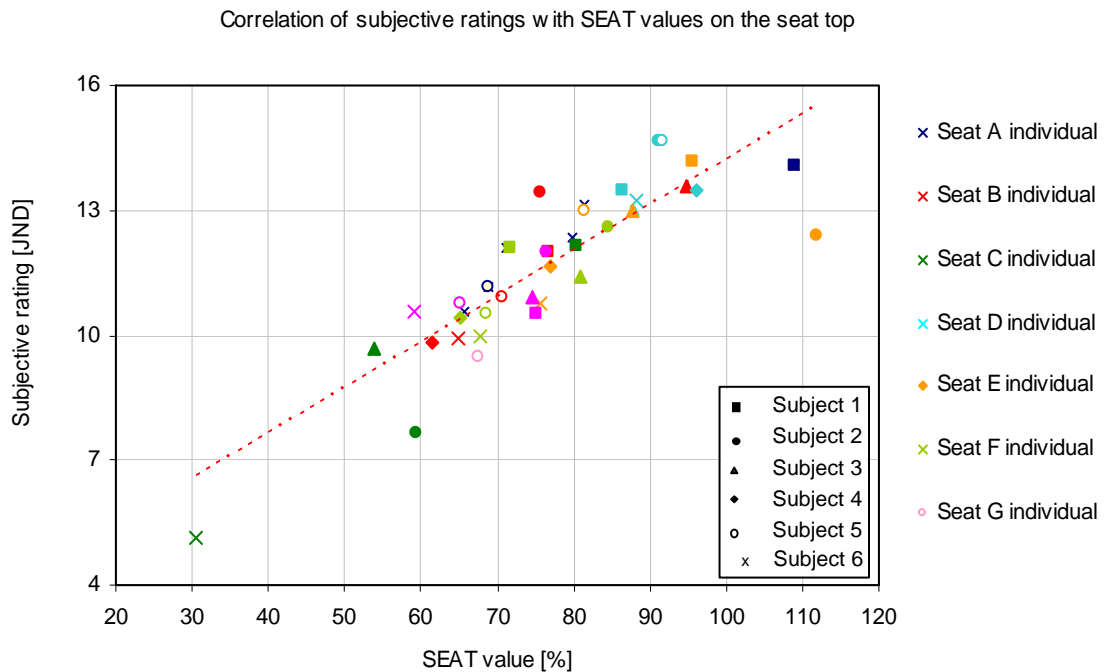
objective and subjective results. The data of Subject 1 has a good correlation with objective data.

The individual data of Subject 2 does not correlate with objective measurements. The reason for this, is the subject's high ride comfort rating on Seat E, despite a high vibration measurement on the seat top. The only explanation for this point is that Subject 2 drives a vehicle that uses the same seat as Seat E. It is suspected that the subject is used to the comfort of Seat E and, therefore, experiences good ride comfort when seated in it. The individual data correlation improves to 0.84 if the data point of Seat E is



**Figure 6.6 Correlation between individual measured SEAT values (vertical track input to vertical output at the seat top) and the individual subjective ratings**

Figure 6.7 shows individual seat comfort data for all subjects on all test seats. There is a good correlation between **individual** subjective and objective seat ride comfort ( $R^2 = 0.75$ ). SEAT values are calculated by using weighting curves that scale vibration according to human sensitivity to vibration. These curves are based on **averaged** sensitivity of a seated human subject to vertical vibration. The individual data is averaged to obtain an average SEAT value and subjective rating for each seat (Figure 6.8).

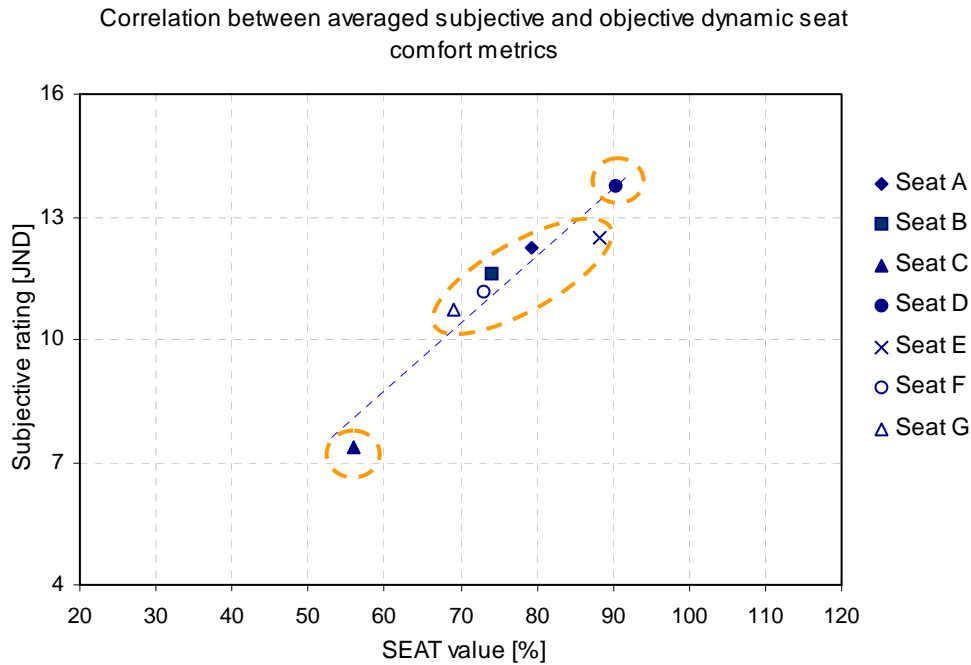


**Figure 6.7 Correlation of all the individual SEAT values with subjective comfort ratings (40 points)**

There is an excellent correlation (Table 6.8) between **averaged** subjective ratings and SEAT values on the seat top ( $R^2 = 0.92$ ). The combination of the multi-axis SEAT values, by calculation of the geometric mean (with Equation 2.5) was discussed in Section 2.6. There is no correlation between the combined SEAT values and subjective ratings ( $R^2 = 0.00$ ). If the in-plane seatback SEAT values are omitted (Equation 2.6) the correlation is  $R^2 = 0.88$ , which is still lower than when only the vertical seat top SEAT values are considered.

Seat C is subjectively and objectively the most comfortable seat for the particular *reference vibration* evaluated. Seat D offers the worst ride comfort

under these conditions. The seats can be divided into three groups: Seats A, B, E, F and G offer average ride comfort, Seat D is the most uncomfortable and Seat C is by far the most preferable.



**Figure 6.8 Average SEAT values for test seats (7 points)**

**Table 6.8 Properties of the straight-line correlation between averaged subjective and objective dynamic seat comfort data**

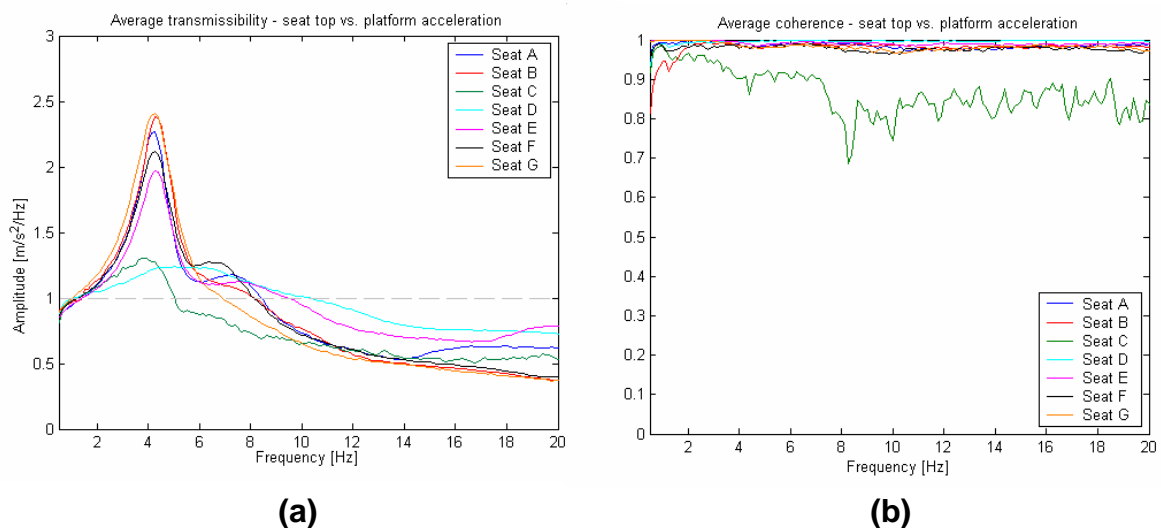
<i>Correlation properties</i>	<i>Averaged (7 points)</i>	<i>Individual (40 points)</i>
$R^2$	0.92	0.75
Slope	0.16	0.11
Intersection	-1.41	3.25

Seats A, B, E, F and G are all car seats. The *reference vibration*, used for paired comparison testing, is a sample of rough gravel road vibration. This explains the seats' average performance in dynamic comfort. Seat G was rated the most comfortable car seat. This indicates good seat design as this vehicle (double-cab pick-up) is driven in applications that often include rough gravel road conditions.

Air-suspension seats, such as Seat C, are usually designed for earth-moving vehicles, where they isolate drivers from large rough road vibrations. This fact explains the superior dynamic seat comfort of Seat C for rough gravel road vibration exposure. It must be added that the passenger compartment of a truck has more space than that of a conventional sedan. This leaves a seat designer with more options to design a dynamically comfortable seat, i.e. sufficient space for a seat that isolates vibration through vertical suspension travel. Thus, the type of vehicle, its application, as well as other factors, such as space and cost, influence dynamic seat comfort.

## 6.4 Seat transmissibility results

SEAT value takes seat transmissibility and human vibration sensitivity into account. Figure 6.9 shows the average transmissibility and coherence between the seat top and platform vertical acceleration at  $1 \text{ m/s}^2$ . Individual seat transmissibility results are plotted in Appendix D. The car seats' (Seats A, B, E, F and G) transmissibility plots show a primary resonance of around 4.2 Hz. This is the seat-occupant mode.



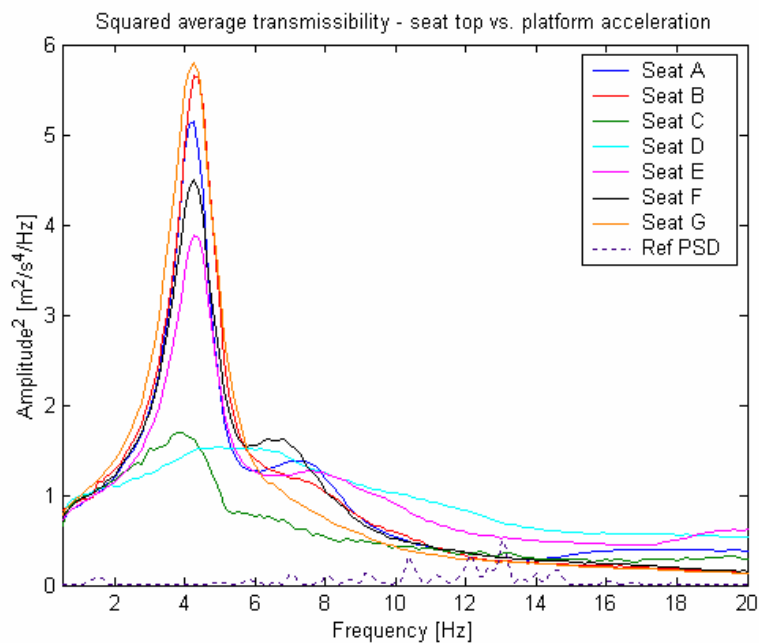
**Figure 6.9 Average seat top (a) transmissibility and (b) coherence**

A secondary mode is found between 6 – 8 Hz and attributed to leg resonance. Seat G shows the greatest vibration amplification at primary resonance (2.4

times) and no leg resonance mode and vibration attenuation above 6.9 Hz. Seat G offers the best vibration attenuation of all the car seats at higher frequencies. Seat F is the greatest amplifier of leg resonance between 6 – 8 Hz.

The car seats display a trade-off between vibration amplification at resonance and attenuation at higher frequencies. Seats that have high vibration amplification at resonance show good attenuation at higher frequencies and vice versa.

Seat C (air-suspension) has a lower primary resonance frequency (3.8 Hz) than the car seats. The non-linear properties of the air spring combine good high frequency vibration attenuation with low amplification (1.3 times) at seat-occupant resonance. The seat isolates the occupant from vertical vibration above 5 Hz. The bad average coherence of Seat C, compared to the other seats, is attributed to the non-linear behaviour of the air spring.



**Figure 6.10 Squared average seat top transmissibility and reference vibration PSD**

A firm sponge was placed on the seat top and seatback of the rigid wooden seat (Seat D) to accommodate seated subjects. Theoretically, an absolutely



rigid seat should have a transmissibility of 1 for all frequencies. The wooden seat and sponge result in a seat-occupant mode at 5 Hz, where the amplification factor is 1.2 and vibration attenuation above 10.3 Hz. Seat D has the lowest vibration amplification and attenuation of all the tested seats.

SEAT values will depend not only on the amplitude, but also on the frequency content of the vibration and the human sensitivity to it. Figure 6.10 shows the square of the average seat top transmissibility of the test seats, plotted with the PSD of the *reference* signal. The *reference* signal displays a rigid body mode at 1.5 Hz. At this frequency, all the test seats have almost the same transmissibility. There is virtually no vibration input at seat-occupant resonance.

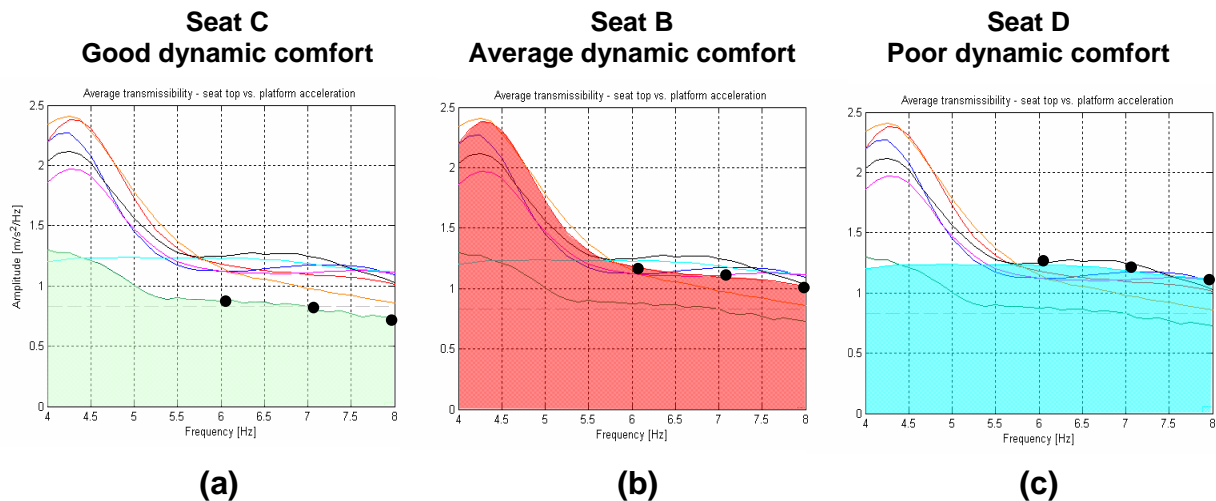
The most vibration input is at 10 Hz and between 12 – 14 Hz (a combined effect of road corrugation and the vehicle's wheel-hop mode). Seat D shows greater vibration transmissibility at these frequencies than any of the other test seats. This explains for the relatively poor ride comfort performance of Seat D. The transmissibility of Seat C is virtually identical to that of Seat B between 10 – 15 Hz. The question might arise as to why Seat C was rated with high dynamic comfort whereas Seat A achieved only average ratings. The answer lies in human sensitivity to vibration.

The frequency weighting, specified for a seated subject in the vertical direction, is  $W_k$ . This curve indicates that seated occupants are most sensitive to vertical vibration with a frequency content between 4 and 8 Hz.

Figure 6.11 shows the average seat top transmissibility curves of all the test seats and the *reference signal* PSD between 4 and 8 Hz. The seat top transmissibility properties of Seat C (good ride comfort), Seat B (average ride comfort) and Seat D (poor ride comfort) are investigated in this frequency range.

The peaks of frequency input are marked on the applicable transmissibility curves for comparison purposes (6.1 Hz, 7.1 Hz and 8 Hz). It is clear that the

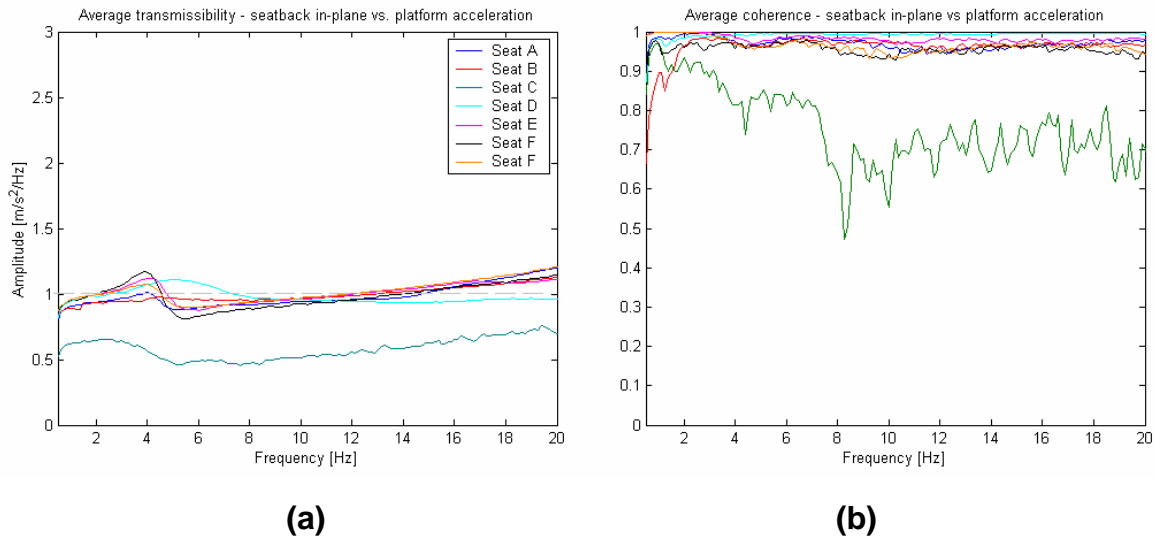
transmissibility of Seat C is significantly lower than that of the other seats for *reference* signal vibrations between 4 and 8 Hz. Seat C is the seat that offers the best vibration isolation from frequencies to which the human body is most sensitive. This accounts for the superior ride comfort performance of Seat C.



**Figure 6.11 Average seat transmissibility of (a) Seat C, (b) Seat B and (c) Seat D between 4 and 8 Hz, with marked energy peaks in the *reference vibration PSD***

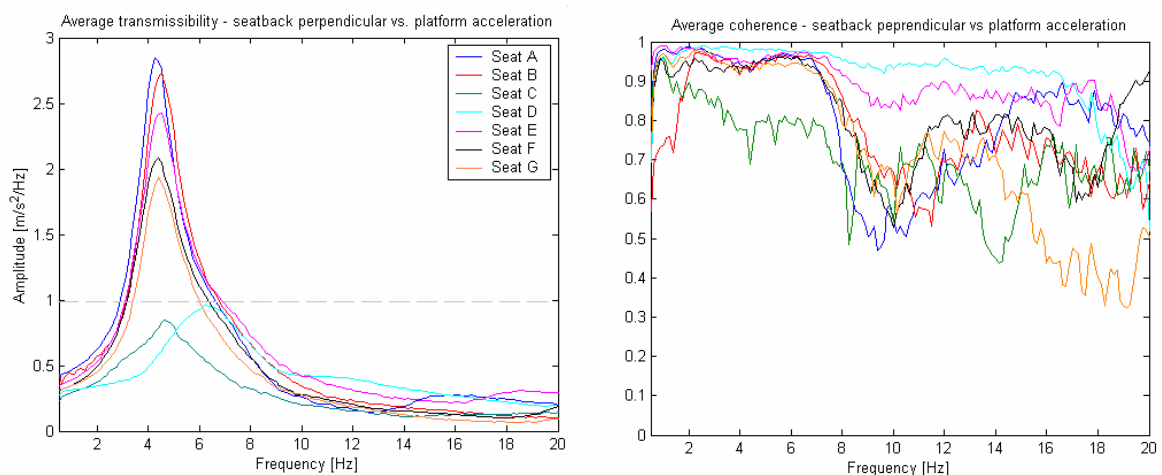
The seat top transmissibility of Seat D (poor ride comfort) is only marginally more than that of Seat B (average ride comfort) between 6 Hz – 8 Hz. The high transmissibility (at 4.3 Hz) of Seat B is not detrimental to its ride comfort due to the lack of vibration input below 6 Hz. The reason why Seat B is dynamically more comfortable than Seat D is because of its superior vibration isolation on the seat top between 10 Hz and 14 Hz, where there is significant vibration input from the *reference signal*.

It is important to note that the dynamic comfort of a seat depends on the vibration input. The best ride comfort is experienced on the seat that offers the best isolation against the frequencies that are excited by a specific road or test. If the test road contained a high vibration input around 4 Hz, Seat B would almost double the vibration on the seat top, whereas Seat D would amplify it 1.2 times. Seat D would outperform Seat B in terms of such an application, even though Seat C would remain the superior seat.



**Figure 6.12 Average transmissibility & coherence of the seatback in-plane and platform acceleration**

The seatback in-plane transmissibility (Figure 6.12) of most of the car seats display a resonance peak around 3.9 Hz. Seat F has the greatest vibration amplification at this frequency and the greatest vibration isolation at 5.5 Hz. Seats A, E, F and G isolate the occupant from seatback in-plane vibration between 4.1 – 4.8 Hz. The seatback in-plane transmissibility of Seat B does not display significant peaks of vibration isolation or attenuation. All the car seats amplify vibration above 12 – 14 Hz.



**Figure 6.13 Average seatback perpendicular (a) transmissibility and (b) coherence**

The air-suspension seat (Seat C) is the only tested seat that isolates the occupant from seatback in-plane vibration at all tested frequencies. The attenuation reaches a minimum around 2.5 Hz, a maximum at 5.2 Hz and decreases towards higher frequencies. Seat D displays seatback in-plane vibration transmission around unity, except around 5 Hz where vibration is amplified by about 12%.

Figure 6.13 shows the average transmissibility between the seatback perpendicular and platform acceleration of all the test seats. The car seats have a resonance peak between 4.3 and 4.5 Hz. The amplification of vibration on the perpendicular seatback is greater than in any other direction. Seat A has the greatest peak transmissibility of backslap vibration (2.8 times). Seat G is the car seat that offers the best vibration isolation in the seatback perpendicular direction (at high and low frequencies).

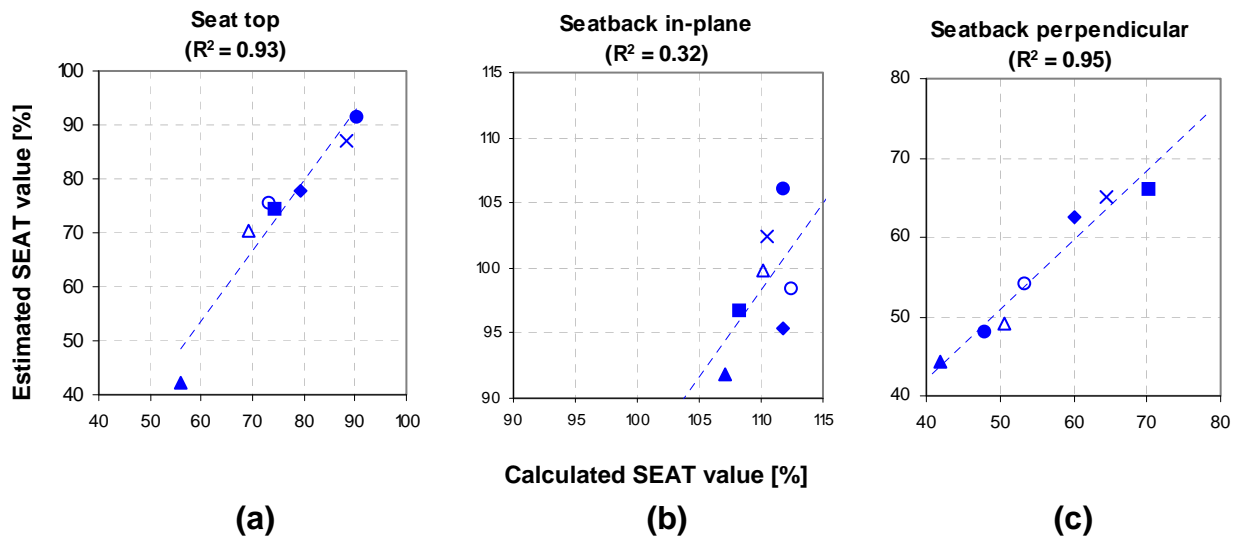
The air-suspension- (Seat C) and rigid seat (Seat D) offer isolation of backslap vibration for the entire measured frequency range. They have transmissibility peaks at 4.6 Hz and 6.3 Hz respectively.

## ***6.5 Estimated SEAT values***

Figure 6.14 demonstrates the correlation between SEAT values that are calculated from direct measurement and SEAT values that are calculated by estimating the seat vibration with the applicable transfer functions. Table 6.9 lists the correlation coefficients, slope and intersection of a linear curve fit through the averaged data points. There is an excellent correlation between the measured and estimated seat top and seatback perpendicular SEAT values.

The lack of correlation between the SEAT values measured and estimated for the in-plane seatback can be attributed to the similar magnitude of the actual SEAT values. All the actual values are concentrated on a small area of the curve. Calculations produce more varying SEAT value estimates due to the

difference in the seatback transmissibility of the test seats. The correlation curve is thus presented with a contradiction of y-values for the same x-value.



**Figure 6.14 Correlation between calculated and estimated SEAT value on the (a) seat top, (b) in-plane seatback and (c) perpendicular seatback**

The estimated SEAT values on the seat top and in-plane seatback over estimate the actual vibration on the seat. Actual SEAT values for perpendicular seatback vibration are generally greater than those predicted by estimates.

**Table 6.9 Correlation between calculated and estimated SEAT value**

<b>Correlation properties</b>	<b>Seat top</b>	<b>Seatback in-plane</b>	<b>Seatback perpendicular</b>
R <sup>2</sup>	0.93	0.32	0.95
Slope	1.30	1.35	0.88
Intersection	-24.42	-50.48	6.65

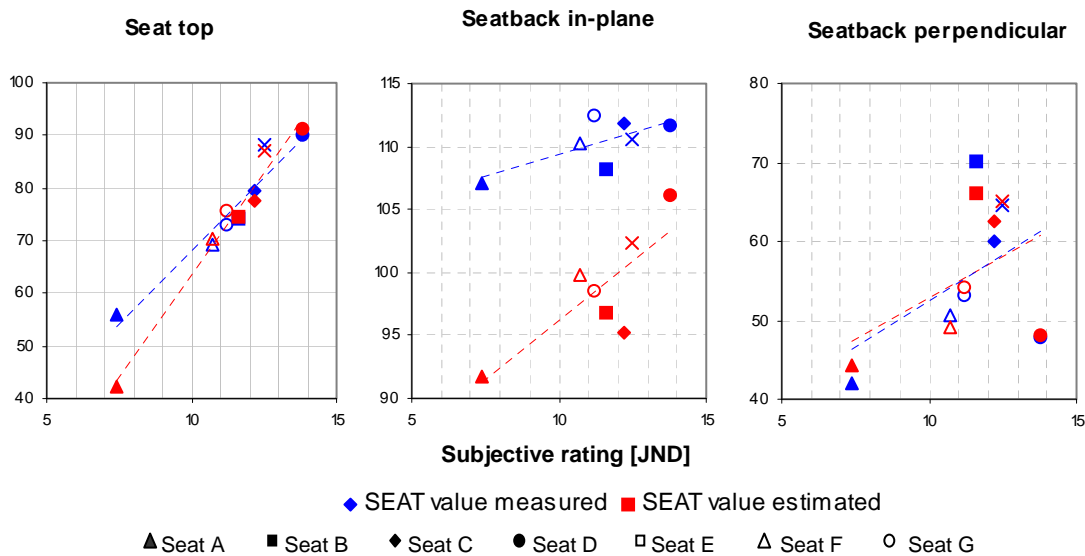
The excellent correlation between estimated and actual SEAT values on the seat top (R<sup>2</sup> = 0.93) and perpendicular seatback imply that objective dynamic seat comfort can be determined indirectly. Accurate SEAT values can be obtained by measuring the applicable seat transfer functions and vehicle floor vibration PSD, without actually measuring the seat vibration. This supports data gathered by Paddan [1999] where a correlation of 0.98 was found between actual and estimated SEAT values on the seat top. Pielemeier et al. [1999] reported a correlation of R<sup>2</sup> = 0.84, and van Niekerk et al. [2001] R<sup>2</sup> =

0.94 between averaged measured SEAT values and estimates from averaged transmissibility.

Furthermore SEAT values on the seat top correlate well with subjective seat comfort ratings ( $R^2 = 0.92$ ). This finding is further substantiated by the fact that:

- SEAT values for the in-plane seatback do not seem to bare relevance to subjective dynamic seat comfort and
- Road vibration does not have inputs at the frequencies to which humans are sensitive to in this direction.

Therefore the lack of correlation between actual and estimated SEAT values on the in-plane seatback does not adversely affect the prediction of dynamic seat comfort from estimated SEAT values.



**Figure 6.15 Comparison of measured and estimated SEAT values during subjective dynamic seat comfort assessment**

The correlations of actual and estimated SEAT values with subjective dynamic seat comfort are compared in Figure 6.15 and Table 6.10. The SEAT values on the in-plane and perpendicular seatback do not correlate with

subjective ratings. The correlation of the in-plane seatback SEAT values with subjective ratings is significantly improved by 15% when using estimates.

The correlation of estimated SEAT values on the seat top is 0.97, compared to 0.92 when using actual values. This agrees with a correlation of  $R^2 = 0.94$  between subjective ratings and estimated SEAT values reported by van Niekerk et al. [2002]. Note that the estimated and actual SEAT values are virtually identical on the seat top for all the seats except Seat C. The significant difference between the actual and estimated SEAT value of Seat C is attributed to the non-linearity of the air-suspension. This indicates that caution should be applied when estimating SEAT values for seats with significant non-linearity.

**Table 6.10 Comparison of measured and estimated SEAT value correlation with subjective dynamic seat comfort assessment**

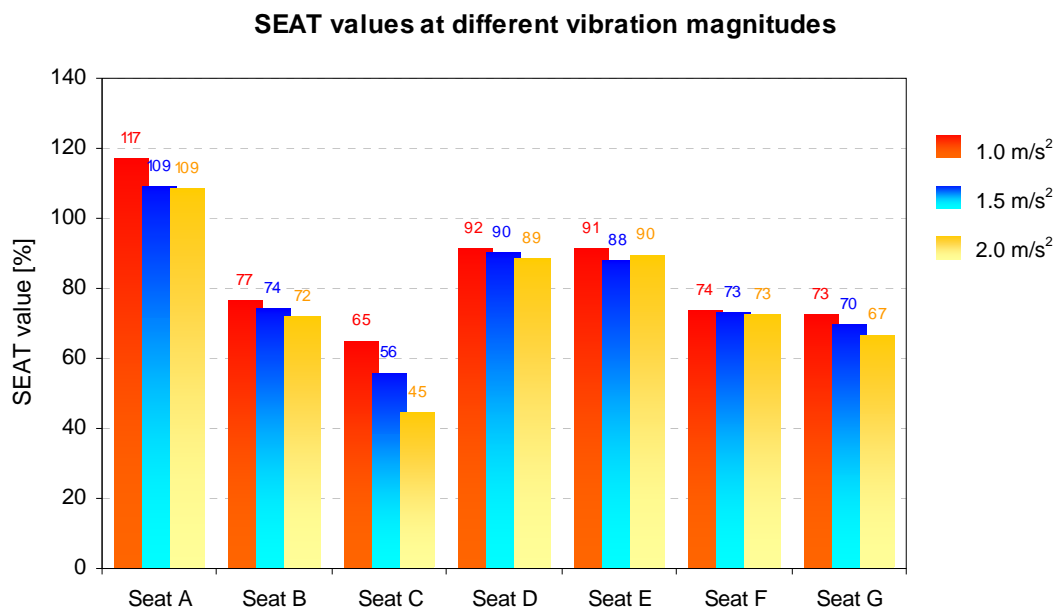
	<i>Seat top</i>		<i>Seatback in-plane</i>		<i>Seatback perpendicular</i>	
	<i>Measured</i>	<i>Estimated</i>	<i>Measured</i>	<i>Estimated</i>	<i>Measured</i>	<i>Estimated</i>
$R^2$	0.92	0.97	0.50	0.65	0.23	0.22
Slope	5.60	7.78	0.70	1.89	2.34	2.08
Intersection	12.22	14.09	102.38	77.27	28.92	32.04

## **6.6 Further observations on SEAT values**

### **6.6.1 SEAT value at different vibration magnitudes**

The actual SEAT values of most test seats remain constant at different vibration magnitudes on the seat top. The objective vibration isolation performance of Seats B, D, E, F and G remain within 6% from its original performance when the vibration magnitude on the platform is varied from 1  $m/s^2$  to 2  $m/s^2$ . The SEAT value of Seat A predicts a dynamic seat comfort improvement of 8% when the vibration magnitude is changed from 1  $m/s^2$  to 1.5  $m/s^2$ .

There is a significant increase of 20% in the dynamic seat comfort performance of Seat C with the increase of input vibration magnitude on the DSTF platform. Again, this is a characteristic of the air-suspension of the seat, where the air spring becomes increasingly harder to compress as the displacement increases with vibration magnitude. The potential of the air-suspension seat is best utilised at higher vibration magnitudes, where it provides maximal vibration isolation to the seated occupant.



**Figure 6.16 SEAT values at different vibration magnitudes**

### **6.6.2 Cross-axis transmissibility on the seatback**

Cross-axis transmissibility in computing SEAT value was discussed in Chapter 2. If it is assumed that the output vibration is simply based on the component of the input vibration that is in the direction of the output, the output magnitude should tend to scale by the cosine of the angle between the output and input. This implies that for the vertical track-in, in-plane seatback-out transmissibility (where the angle was 24°) should display low frequency gains around  $\cosine\ 24^\circ = 0.9$ . Where the angle was  $90 - 24 = 66^\circ$ , as is the case with the vertical track-in, perpendicular seatback-out transmissibility, low frequency gain magnitudes should match  $\cosine\ 66^\circ = 0.4$ .



These statements are supported by the in-plane and perpendicular seatback transmissibility measurements that have low frequency values of 0.9 and 0.4 respectively (Figure 6.12 (a) and 6.13 (a)). These observations are in accordance with data gathered by van Niekerk et al. [2002]. This implies that Equation 2.4 should be used to calculate SEAT values for the seatback.

**Table 6.11 Comparison of traditional SEAT values and SEAT values assuming that the input vibration is a component in the direction of the output**

Seat	Seatback in-plane		Seatback perpendicular	
	SEAT %	SEAT % ( $\theta_{fs} = 24^\circ$ )	SEAT %	SEAT % ( $\theta_{fs} = 66^\circ$ )
A	102	112	60	148
B	99	108	70	172
C	98	107	42	103
D	102	112	48	118
E	101	110	65	159
F	103	112	53	131
G	101	110	51	124

Table 6.11 lists a comparison of traditionally calculated SEAT values on the seatback and ones calculated from the assumption that the input vibration is a component of the vertical seat input in the direction of the output vibration on the seatback. The interpretation of seatback vibration isolation performance is radically affected when implementing the mentioned assumption. The new set of SEAT values indicates that seatback in-plane vibration is slightly amplified and not equally transmitted as previously believed. Vibration is not isolated, but amplified in the perpendicular seatback direction.

This concludes the summary of the experimental results from dynamic seat comfort assessments. Conclusions from these results and future work are discussed in Chapter 7.



# Conclusions and future work

This chapter includes conclusions on the result of the research into SEAT values and improvements in the method of using paired comparisons for subjective seat comfort assessment.

In this study it has been shown that paired comparison tests are a very conclusive subjective dynamic seat comfort assessment technique. Paired comparison techniques eliminate subject bias and static seat comfort from the dynamic seat comfort assessment. **This study shows that a 2-up-1-down, two-track interleaved, Levitt-procedure is more efficient and accurate than the psychometric function method of constants, used by Greenberg et al. [1999] to assess dynamic seat comfort.** The greater efficiency of the 2-up-1-down, two-track interleaved, Levitt procedure is attributed to its adaptive nature, which results in the gathering of less unnecessary data. *Alternative stimuli* were scaled 1 JND apart instead of 3 JNDs, which improved the accuracy of the level of convergence. Procedure reliability was improved by averaging two independent tracks that confirm the level of convergence. The interleaved fashion of the tracks eliminates subject bias as it disguises the converging pattern of the Levitt procedure.

The reference stimulus used for dynamic seat comfort assessment was a road vibration recording with an r.m.s. value of  $1.5 \text{ m/s}^2$  at the seat track. The PSD of the input signal shows that the input vibration has most of its energy between 10 - 15 Hz (wheel-hop mode and road corrugation), but also some vibration between 4 - 10 Hz (containing seat-occupant mode) and at 2 Hz (rigid body mode). The reference stimulus used by Van Niekerk et al. [2002]

was a rough road vibration with most of its energy concentrated between 12 - 16 Hz and an r.m.s. value of  $1.6 \text{ m/s}^2$  at the seat track. **Subjective dynamic seat comfort has now been correlated with estimated SEAT values on the seat top for two different road vibrations.**

Objective dynamic seat comfort was determined by calculating SEAT values from vibration measurements on the test seats and floor for the reference vibration input. An additional set of SEAT values were calculated by estimating the vibration on the seat from the measured seat transmissibility. **The correlation between the measured and estimated SEAT values is very high on the seat top ( $R^2 = 0.93$ ) as well as on the perpendicular seatback ( $R^2 = 0.95$ ).** This gives one confidence to use only reliably measured transmissibility functions to estimate SEAT values.

The six subjects who participated in this study were carefully selected to comprise a profile that represents the composition of a population (one 5<sup>th</sup> percentile female, two 50<sup>th</sup> percentile females and males and one 95<sup>th</sup> percentile male). The results show an enormous improvement in the correlation between measured and estimated SEAT values and subjective-objective dynamic seat comfort, when individual values are averaged over the test subjects. Van Niekerk et al. [2002] reported the same improvements in the correlation of averaged results for six subjects selected according to the same criterion. **This study confirms averaging the results of six carefully selected subjects to predict dynamic seat comfort of seven seats.**

There was good correlation between all the individual subjective and objective dynamic seat comfort assessments of the 6 test subjects for the 7 test seats (40 points,  $R^2 = 0.75$ ). The individual values of the test subjects were then averaged, resulting in **excellent correlation between the averaged subjective assessment and SEAT values on the seat top.** For actual SEAT values, measured on the seat top, the correlation was  $R^2 = 0.92$  and for estimated SEAT values the correlation improved to  $R^2 = 0.97$ . Van Niekerk [2002] reported similar results between averaged subjective data and SEAT values estimated from average transmissibility on the seat top ( $R^2 = 0.94$ ).

**The conclusions of this study suggest that the SEAT values, estimated from averaged seat top transmissibility of six carefully selected subjects, could be used to select the best seat for a specific road vibration input.**

**There is no correlation between subjective dynamic seat comfort and SEAT values on the seatback or between measured and estimated SEAT values on the in-plane seatback.**

**The relevance of seatback vibration and SEAT values on dynamic seat comfort is unknown as SEAT value fails to correlate with subjective assessments.** The SEAT values for the in-plane seatback vibration only vary with about 5%. The calculation of seatback SEAT values with the assumption of cross-axis transmissibility implies that the test seats have SEAT values of around 100% and 56% respectively in the in-plane and perpendicular directions. The interpretation of seatback performance is very different if it is assumed that the output vibration is a component of the input vibration in the output direction, modified by system mechanical properties. The respective SEAT values of the in-plane and perpendicular seatback change to 110% and 140% under this assumption. The study by Van Niekerk et al. [2002], confirms these observations.

Combined multi-axis SEAT values fail to correlate well with subjective dynamic seat comfort ratings ( $R^2 = 0.00$ ). There is a good correlation between subjective ratings and the combination of vertical SEAT values in the seat top and perpendicular seatback. ( $R^2 = 0.88$ ). Van Niekerk et al. [2002] reported correlations of  $R^2 = 0.78$  in both the aforementioned cases. **It seems that the best one can do is to only consider the vertical seat top response when attempting to correlate objective response with subjective ratings.**

**Future work includes further investigation into the relevance of seatback vibration on dynamic seat comfort and the mechanics of vibration transmission to the seatback.** If seatback vibration contributes significantly

to dynamic seat comfort a metric that correlates scientific measurements with subjective dynamic seatback comfort perception remains to be identified or developed.

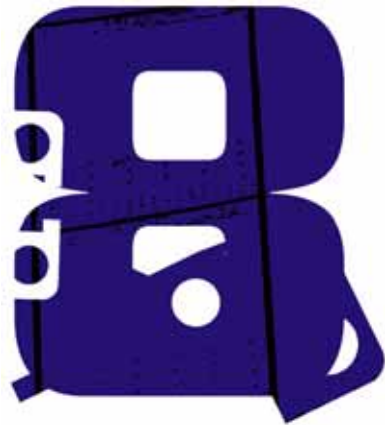
**Further improvement of the subjective dynamic seat comfort assessment procedure is possible by implementing the rigid seat method.** Research up to this point has compared the ride of each subject on each test seat with the ride experienced by the *reference* subject on the *reference* seat. The whole-body impedance of the *reference* subject might cause vibrations to occur on the seat top that would be damped out by another test subject. The reconstruction of the virtual *reference* on the seat could induce vibrations that a subject never feels and therefore interprets as uncomfortable. This can be overcome by recording a virtual *reference* for each subject on each seat. The recorded road stimulus would be played at the seat track of each seat for each subject while recording the vibration on the seat cushion. **The subjects would participate in a single paired comparison test (opposed to a paired comparison test for each subject on each seat) where the reference signals are compared on a rigid seat.** The paired comparison procedure would consist of reconstructing random trials of the same subject's ride on the different test seats on the seat top of the rigid seat.

Paired comparison results from the rigid seat method would be analysed with the Bradley-Terry method [David, 1988, p.61]. This would result in a seat ranking of all the seats for each subject that completes a single paired comparison test. The seat ranking would be in terms of the probability that the subject would prefer the dynamic comfort of each seat (the sum of the probability ratings of the test seats for a subject is equal to 1). **The probability ranking of the seats averaged over six test subjects (selected according to the criterion mentioned in Section 3.4) could be correlated with averaged objective data.**

Averaged subjective dynamic seat comfort has correlated well with SEAT values on the seat top for two road stimuli with different vibration contents.

**The question arises as to whether two studies are sufficient to substantiate the extensive use of these promising conclusions by industry.** The consolidation of this work includes the study of subjective-objective correlation for other vibration stimuli.

The optimal seat is one that considers dynamic seat comfort, along with the many considerations that influence seat design. Future work includes the scientific assessment of the significance of dynamic seat comfort in commercial vehicles relative to other seat design considerations such as space, safety, cost, and the application of the vehicle. **The work of this study will only contribute to industrial seat design when dynamic seat comfort is included in a set of design guidelines.**



# References

1. **Van Niekerk JL, Pielemeier WJ, Greenberg JA;** 2002, The use seat effective amplitude transmissibility (SEAT) values to predict dynamic seat comfort, *Journal of Sound and Vibration*, Vol.260 (2003) p.867 - 888.
2. **Pielemeier WJ, Greenberg JA, Jeyabalan V, van Niekerk JL;** 2001 The estimation of SEAT values from transmissibility data, *Society of Automotive Engineers World Congress*, Detroit, USA, SAE 01B-152.
3. **Greenberg JA, Jeyabelean V, Meier RC, Pielemeier WJ;** 1999, Dynamic subjective evaluation of 16 automobile seats, *Ford Research Laboratory*, Dearborn, USA, Project no. AJ452.
4. **Greenberg JA, Jeyabalan VJ, Meier RC, Pielemeier WJ;** 1998, The dynamic characteristics of 16 automobile seats, *Ford Research Laboratory*, Dearborn, USA, No.AJ452.
5. **Pielemeier WJ, Jeyabelan V, Meier RC, Otto NC;** 1997, Just noticeable differences in vertical vibration for subjects on an automobile seat, Presented at the 32<sup>nd</sup> United Kingdom Group Meeting on human response to vibration held at the ISVR, University of Southampton, Southampton, England, 17 - 19 September.

6. **Pielemeier WJ, Greenberg J, Meier R, Jeyabelan V, Amman S;** 1999, Comparison of SEAT values from transmissibilities vs. direct measurements for 16 seats and 6 subjects, Presented at the 34<sup>th</sup> United Kingdom Group Meeting on human response to vibration held at Ford Motor Company, Dunton, Essex, England, 22 - 24 September.
7. **Levitt H;** 1971, Transformed up-down methods in psychoacoustics, The Journal of the Acoustical Society of America, Vol. 49 No. 2 (part 2), p.467 - 477.
8. **Jesteadt W;** 1980, An adaptive procedure for subjective judgements, Perception and Psychophysics, Human Communication Laboratories Boys Town Institute for Communication Disorders in Children, Omaha, Nebraska, Vol. 28(I) p.85 - 88.
9. **Griffin MJ;** 1990, *Handbook of human vibration*, Human Factors Research Unit, Institute of Sound and Vibration Research, The University of Southampton, England, Academic Press Limited, London.
10. **Kolich M;** 1999, Reliability and validity of an automobile seat comfort survey, Society of Automotive Engineers World Congress, Detroit, USA, SAE 1999-01-3232.
11. **ISO 2631:1997**, Guide for the evaluation of human exposure to whole-body vibration, International organisation for standardisation (ISO).
12. **ISO 10326-1:1992**, Mechanical vibration – laboratory method for evaluating vehicle seat vibration, International organisation for standardisation (ISO).
13. **ISO 7096:2000**, Earth-moving machinery – laboratory evaluation of operator seat vibration, International organisation for standardisation (ISO).

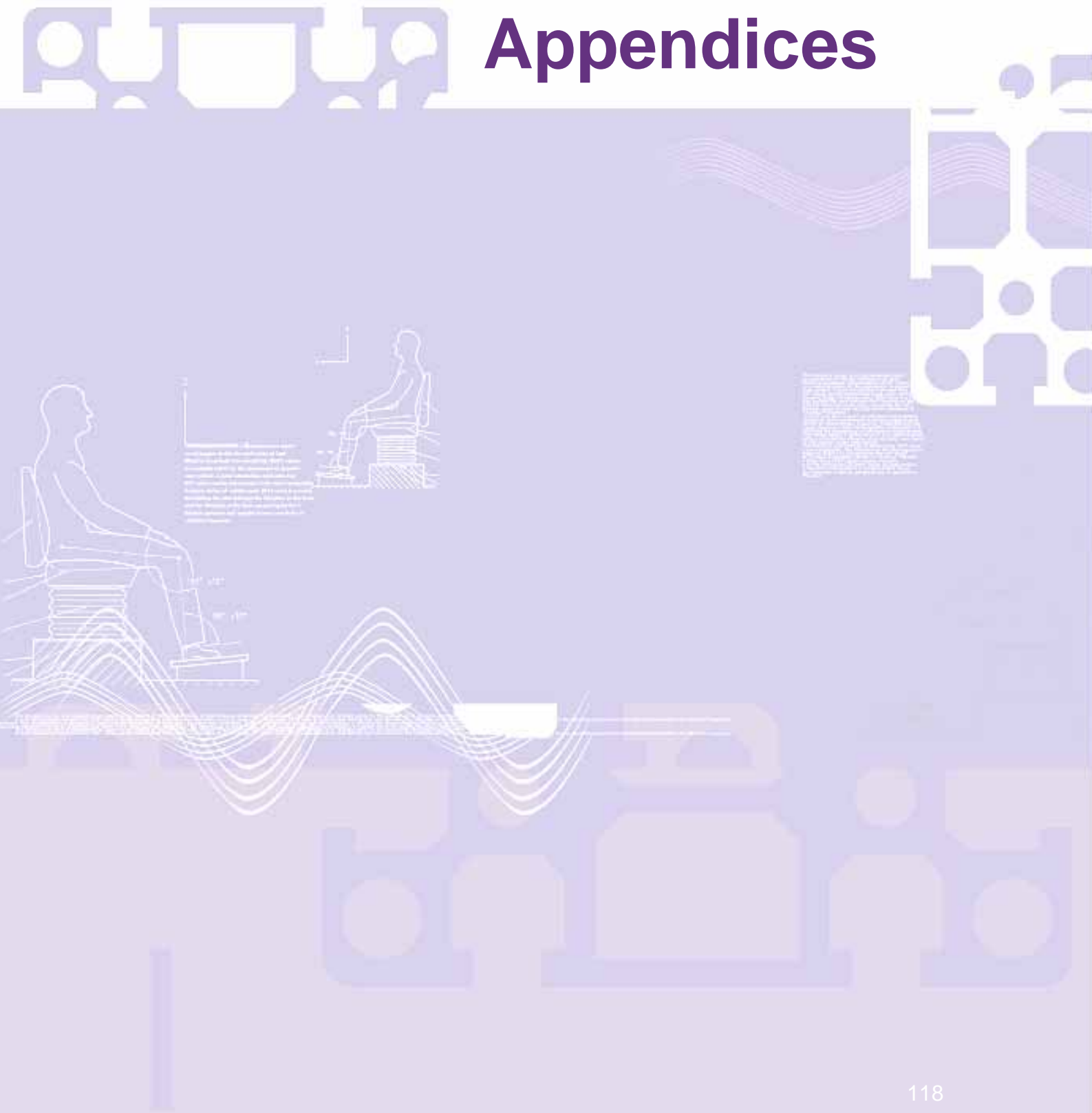


14. **ISO 5353:1998**, Earth-moving machinery, and tractor and machinery for agriculture and forestry – seat index point, International organisation for standardisation (ISO).
15. **BS 6841**, 1987, British standard guide to measurement and evaluation of human exposure to whole-body mechanical vibration and shock, British Standards Institution, London.
16. **Mansfield JN**; 2001, Localized vibration at the automotive seat-person interface, The 2001 International Congress and Exhibition of Noise Control Engineering, The Hague, The Netherlands, INCE:49.134, 27 - 30 August 2001.
17. **Paddan GS**; 1999, Prediction of seat effective amplitude transmissibility values for 8 alternative car seats, Presented at the 34<sup>th</sup> United Kingdom Group Meeting on Human Response to Vibration, Held at Ford Motor Company Ltd, Dunton, Essex, 22 - 24 September.
18. **Parsons KC and Griffin MJ**; 1983, Methods for predicting passenger vibration discomfort, Society of Automotive Engineers, Warrendale, PA, USA, SAE 831029.
19. **Kazushige O and Ebe K**; 1998, Models of overall seat discomfort, Presented at the 33<sup>rd</sup> United Kingdom Group Meeting on Human Response to Vibration held at the Safety Executive, Buxton, Derbyshire, England, 16 - 18 September.
20. **Kolrep H**; 2001, Assessing and predicting the impact of cowlshake in convertible cars on subjective comfort, International Driving Symposium on Human Factors in Driver Assessment, Training and Vehicle Design, Snowmass Village at Aspen, Colorado, 14 - 17 August.

21. **Smith SD**; 1997, Limitations in predicting human vibration response characteristics from manikins and rigid body masses, The Engineering Society for Advancing Mobility Land Sea Air and Space, International Congress and Exposition, Detroit, Michigan, SAE 970598, 24 - 27 February.
22. **Zwicker E, Fastl H**; 1990, *Psychoacoustics Facts and Models*, Second Updated Edition, Springer Series in Information Sciences, Munich, p.10.
23. **Govindswamy K, Hartwig M, Alt N, Wolff K**; 2004, Designing sound to build character, The Journal of Sound and Vibration, p.172, February.
24. **Griffin MJ**; 1998, International Standard 2631 and British Standard 6841: a comparison of two guides of measurement and evaluation of human exposure to whole-body vibration and repeated shock, Proceedings of a joint French-British meeting, Groupe Francais des Etudes des Effects des Vibrations sur l'Homme and United Kingdom Informal Group on Human Response to Vibration, INRS, Vandoeuvre, France, 26 - 28 September.
25. **Muira S**; 1973, *Sensory Evaluation Handbook*, Research committee of sensory evaluation, Union of Japanese Scientists and Engineers, JUSE Press. Ltd., Tokyo, Chapter 10.
26. **Varterasian JH**; 1982, On measuring automobile seat ride comfort, Society of Automotive Engineers, Warrendale, PA, USA, SAE 820309.
27. **Robbins H, Monro S**; 1951, A stochastic approximation method, Annals of Mathematical Statistics, Vol. 22, p. 400 – 407.

28. **David AH**; 1988, *The Method of Paired Comparisons*; Second Edition, Revised, Iowa State University, Charles Griffin and Company Ltd., London, p.7 - 8 and p.57 - 65.
29. **Bellman MA, Volker M, Remmers H, Weber R**; 2000, Experiments on the perception of whole body vibration, Presented at the 35<sup>th</sup> United Kingdom Group Meeting held at the Institute on Sound and Vibration Research, Southampton, England, p. 355 - 364, 13 - 15 September.

# Appendices



## APPENDIX A

# Characterisation of the experimental rig

Vehicle floor-pan acceleration displays three vibration modes, rigid-body mode, seat-occupant mode and wheel-hop mode. These three modes are the dominant sources of vibration input to seat. An investigation into dynamic seat comfort is predominantly occupied with how well the seat isolates the occupant from these vibration modes. Varterasian [1982] states that vehicle floor-pan vibration modes occur below 20 Hz. This frequency range is taken as the relevant frequency interval for the investigation of dynamic seat comfort in this study. Consequently, the experimental rig itself should not display any vibration modes in the 0 – 20 Hz frequency range.

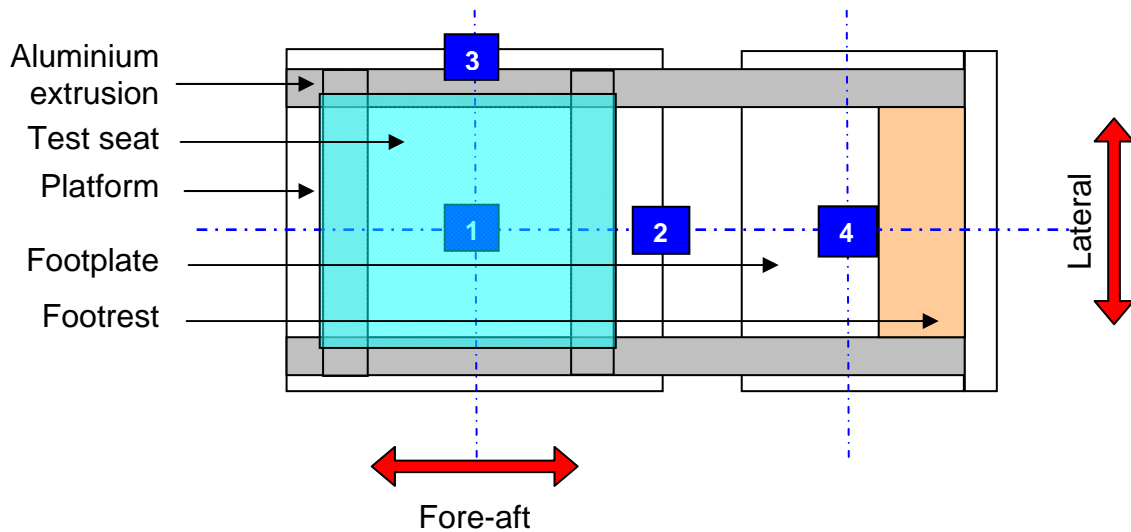
### ***A.1 DSTF vibration characteristics in the 0 – 20 Hz range***

The exposure of subjects to vibrations with a frequency content of 0 – 20 Hz implies that the experimental rig may not display any vibration modes in this frequency range. If a mode should, occur a subject would experience the combined effect of the vibration modes of the test seat and the rig. This is undesirable as we are trying to isolate the response of human occupants to the dynamic characteristics of the seat.

In order to prove that the DSTF has no vibration modes in the desired frequency range we set out to prove that:

- Vertical vibration on the platform is uniform regardless of the location of measurement.
- The footplate-footrest assembly does not display vibration modes between 0 – 20 Hz.
- Lateral and fore-aft vibration is negligible.

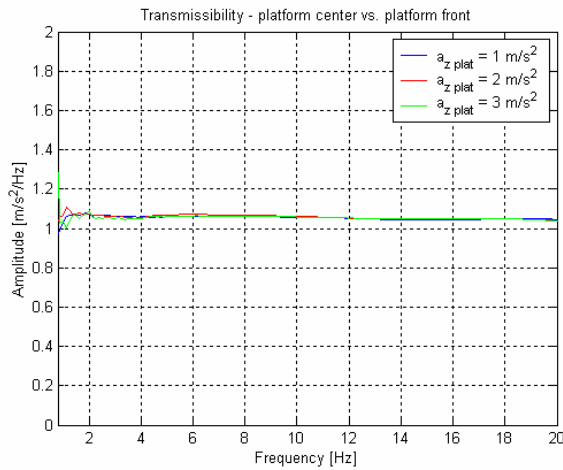
To prove the above, mentioned criteria, acceleration measurements were taken at different locations on the rig as shown in Figure A.2. The reference subject was seated on the reference seat for the purpose of these measurements.



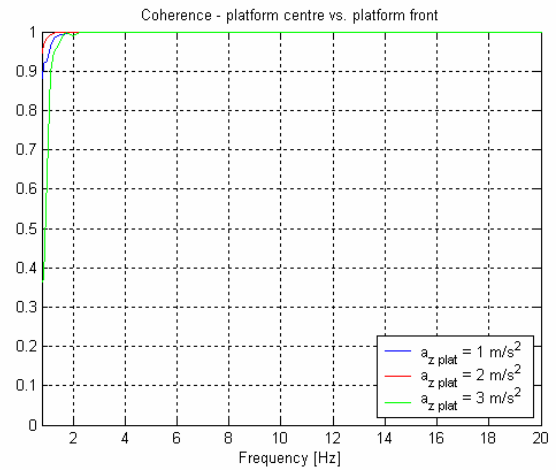
**Figure A.1 Top view of the platform with sensor locations for DSTF modal tests**

Location 1 marks the centre of the DSTF platform, with locations 2 and 3 on the front-centre and side-centre extremes respectively. To prove uniform vibration on the platform, the transmissibility of the vertical acceleration measurements between location 1 and locations 2 and 3 should approach 1 between 0 – 20 Hz.

Figure A.3 and Figure A.4 show transmissibility and coherence results at 1  $m/s^2$ , 2  $m/s^2$  and 3  $m/s^2$  for the vertical vibration on the centre of the platform, vs. the front and the side of the platform. In both cases the transmissibility approaches a constant level of 1.05, implying that vibration at the platform extremes are 5% more than those measured at the centre of the platform.

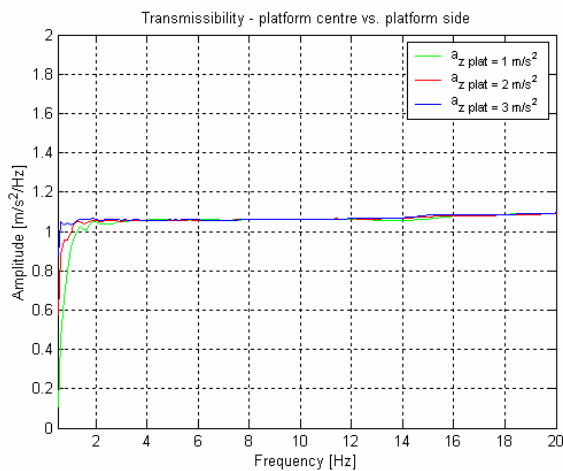


(a)

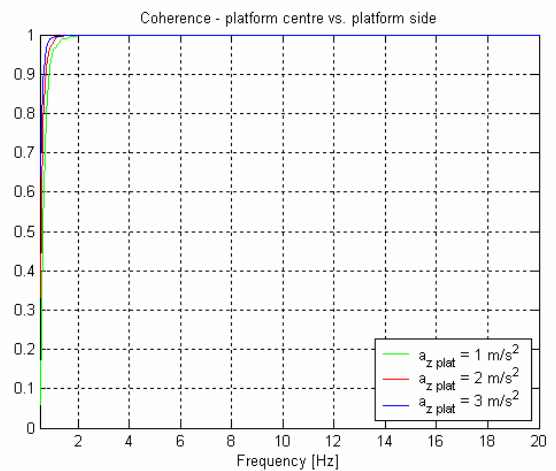


(b)

**Figure A.2 (a) Transmissibility and (b) coherence of vertical platform centre vibration (location 1) vs. platform front vibration (location 2)**



(a)



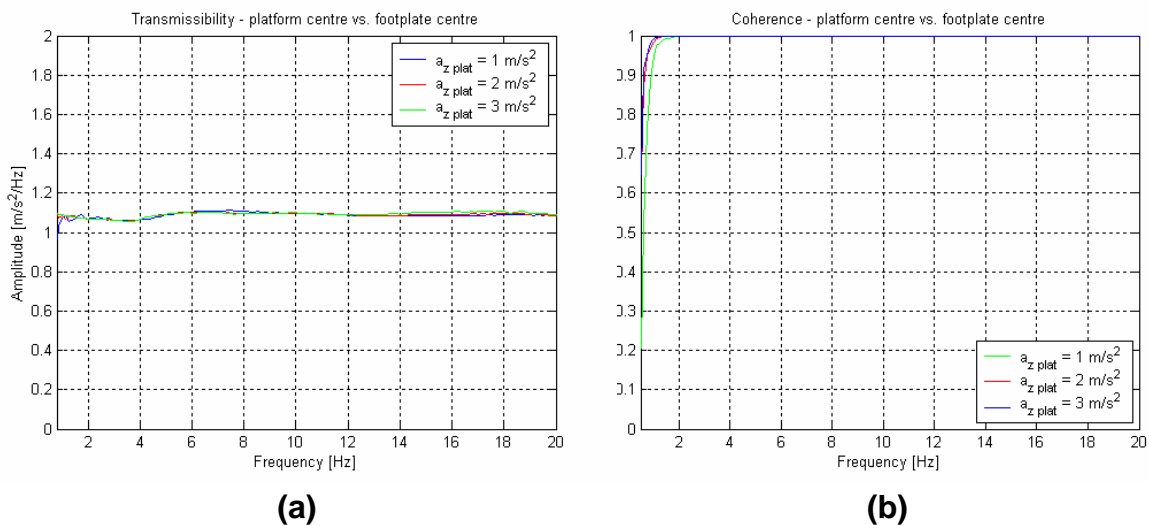
(b)

**Figure A.3 (a) Transmissibility and (b) coherence of vertical platform centre vibration (location 1) vs. platform side vibration (location 3)**

The transmissibility between the platform centre and the platform front acceleration displays a small peak between 6 – 8 Hz. This can be attributed to the closer proximity of location 2 to where the subject's feet are placed on either side of location 4 (the frequency range of seated occupant leg resonance). A slight increase occurs in the transmissibility between the platform centre - and the platform side vibration above 14 Hz. Non-linearity does not seem to have a significant effect above 1.5 Hz and is most prominent at lower vibration magnitudes and frequencies. Since the smallest

perceptible difference in vibration is 10% (1 JND) and the difference in vibration on the platform is 5%, *the vibration on the platform is taken to be uniform.*

The transmissibility between the vertical vibration on the centre of the DSTF platform and the centre of the footplate approaches 1.08, as shown in Figure A.5. There is a slight peak in the transmissibility between 6 and 8 Hz that can be attributed to the resonance frequency of the subject's legs. The effect of non-linearity is most obvious at these frequencies at a platform vibration magnitude of 1 m/s<sup>2</sup>, at which point the vibration on the footplate is 11% greater than that measured on the centre of the platform. Even though this vibration difference is greater than 1 JND (10%), it is expected, since the measurement location (location 4) is a contact region between the rig and test occupant. The difference in vibration between the centre of the platform and the footplate can be attributed to a vibration mode of the test occupant and not of the rig itself. Therefore, it is assumed that *the footplate and footrest have no vibration modes below 20 Hz.*



**Figure A.4 (a) Transmissibility and (b) coherence of vertical platform centre (location 1) vs. footplate centre vibration (location 4)**

Vibration measurements were taken in the fore-aft direction at location 2 and in the lateral direction at location 3. Negligible (less than 10%) vibration was measured in these directions, resulting in transmissibility functions that tend



toward zero and bad coherency due to too little vibration input. It is concluded that *the platform experiences negligible vibration in the fore-aft and lateral directions.*

The DSTF displays no vibration modes below 20 Hz and is suitable for dynamic seat comfort testing in this frequency range.

## APPENDIX B

# Steps of the dynamic seat comfort assessment procedure

### ***B.1 Prepare seat and position accelerometers***

#### ***B.1.1 Seat positioning***

- i.)* Mount the test seat on the platform, with the seat rails horizontal.
- ii.)* Ensure that all bolts on the seat and aluminium extrusions are securely tightened and rattling parts are removed from the test seat.
- iii.)* Ensure that the seatback inclination meets 24° to the global vertical.
- iv.)* Measure and note the seat top cushion (uncompressed) angle at the acceleration measurement location (**128 mm** to the front of the point, marked by the straight-line intersection of the seatback with the seat pan).
- v.)* Reposition the seat, using the SIP-gauge [as described in *ISO 7096:2000*]; so that the SIP is in the correct location relative to the intersection between the sloped side of the footrest and footplate, for the specific subject to be tested.

#### ***B.1.2 Accelerometer mounting***

- i.)* Mount the platform accelerometer securely on the provided measurement location in centre of the platform.
- ii.)* Secure a seat pad accelerometer, bulge side up, onto the seat base. The centre of the accelerometer should be in the middle of the seat, **128 mm** to the front of the point, marked by the straight-line intersection of the seatback with the seat top.

- iii.) Mount another seat pad accelerometer, bulge side down, onto the seatback, centred **320 mm** vertically from the seat top cushion (*uncompressed*) surface.
- iv.) Ensure that all accelerometer cables are secured in such a way that the movement of the DSTF platform does not damage them.

## **B.2 Prepare subject**

### **B.2.1 Indemnity & documentation**

- i.) Brief the subject on purpose and method of testing (first test only)
- ii.) Sign information- & informed document of consent (first test only)
- iii.) Remind the subject that he/she can terminate the test procedure at any time and request him/her to inform the operator of fatigue or the onset of a lack of concentration (all tests).
- iv.) Record subject exposure to mechanical vibration for each test and report test conditions and any abnormalities (throughout all tests).

### **B.2.2 Clothing**

- i.) Instruct subject not to wear unusually thick clothing
- ii.) To empty all pockets.

### **B.2.3 Sitting position**

- i.) The subject is not allowed to alter the seat position as the seat was pre-positioned, using the consistent SIP position for the specific test subject.
- ii.) Instruct the subject to place his/her heels at the intersection of the sloped side of the footrest with the footplate, with thighs supported by seat base.
- iii.) Sit in a relaxed comfortable, but upright position

- iv.) Legs in normal sitting position and not spread
- v.) Hands placed on the subject's lap, one hand on each thigh
- vi.) Play a white noise signal (at 80 dBA) through the headset, worn by the subject.

### ***B.3 Measure seat transmissibility functions***

#### ***B.3.1 Reconstruct vibration for transmissibility measurement***

- i.) Specify input displacements for the measurement of seat transmissibility by the input displacement frequency profile (motivated in Chapter 3).
- ii.) Scale the input displacement to obtain platform vibrations with r.m.s. values of  $0.5 \text{ m/s}^2$ ,  $1 \text{ m/s}^2$ ,  $1.5 \text{ m/s}^2$  and  $2 \text{ m/s}^2$  with a frequency content of 0.5 – 20 Hz.

#### ***B.3.2 Measure seat transmissibility***

Measure **three seat transmissibility functions** for each vibration magnitude  $0.5 \text{ m/s}^2$ ,  $1 \text{ m/s}^2$ ,  $1.5 \text{ m/s}^2$  and  $2 \text{ m/s}^2$  (shown in Figure 5.1)

The transmissibility between:

- i.) **Vertical acceleration** on the **platform** ( $a_{z\_plat}$ ) and **vertical acceleration** on the **seat top** ( $a_{z\_seat\ top}$ )
- ii.) **Vertical acceleration** on the **platform** ( $a_{z\_plat}$ ) and the **seatback acceleration (in-plane vertical** ( $a_{z\_seatback}$ ))
- iii.) **Vertical acceleration** on the **platform** ( $a_{z\_plat}$ ) and the **seatback acceleration (perpendicular to seatback plane** ( $a_{x\_seatback}$ ))

## ***B.4 Measure frequency response functions***

### ***B.4.1 Reconstruct vibration for FRF measurement***

- i.)* Specify input displacements for the measurement of seat transmissibility by the input displacement frequency profile (motivated in Chapter 3).
- ii.)* Scale input displacement to obtain a platform vibration with a r.m.s. value of  $1.5 \text{ m/s}^2$  and a frequency content of 0.5 – 20 Hz .

### ***B.4.2 Measure frequency response functions***

Measure **three frequency response functions** at a platform vibration magnitude of  $1.5 \text{ m/s}^2$  r.m.s. The FRF between the:

- i.)* **Input displacement command ( $X_{in}$ ) signal and vertical platform acceleration ( $a_{z \text{ plat}}$ )**
- ii.)* **Input displacement command ( $X_{in}$ ) and vertical seat top acceleration ( $a_{z \text{ seat top}}$ ;**
- iii.)* **Input displacement command ( $X_{in}$ ) and the LVDT output response ( $X_{LVDT}$ )**

## ***B.5 Reference signal and alternative stimuli files***

### ***B.5.1 Reconstruct the reference signal on the seat top***

The *reference signal* is reconstructed on the seat top, for each subject on each test seat.

- i.)* Estimate the required input voltage for reconstructing the *reference vibration* on seat surface. Calculate an approximation of the input

- displacement using the **frequency response function** between the **seat top acceleration** and the **voltage input displacement** (at the reference vibration level).
- ii.) Displace the platform with the estimated input voltage and measure the system response on the seat surface and shaker platform.
  - iii.) Calculate the error between the response on the seat surface and the desired response (on the seat surface) in the **frequency** and **time domain**. This error should not exceed 10% of the reference vibration as this represents one JND (which implies a perceptible difference in vibration to the subject).
  - iv.) If the response error is greater than 10%, an **input error** is calculated. The response error is expressed in the frequency domain and the input error is determined through the **frequency response function** between the **seat top acceleration** and **input displacement voltage**. The input error is added to the estimated input displacement. ITERATE until response error < 10%. Failure to achieve this, results in the **termination** of the subjective ride comfort test.
  - v.) If the response error is smaller than 10%, the recorded **platform vibration** (which results in the *reference vibration* on the seat top) is saved and used to construct the input signals for the Levitt paired comparison test.

### ***B.5.2 Scale test stimuli and create input command signals***

- i.) Scale the *road vibration recording* to both sides (larger and smaller) with a factor of 1.1, resulting in a series of vibrations that are 1 JND apart (Figure 5.3).
- ii.) **Create 60 vibration signal files** that comprise of the *reference* signal and an *alternative* stimulus. These files include all possible trials that can occur within safe acceleration and displacement limits of the actuator

## ***B.6 Subjective seat comfort assessment***

### ***B.6.1 The 2-up-1-down, two-track interleaved, Levitt procedure***

- i.)* Play the reference signal back-to-back with the vibration alternatives in an interleaved fashion (using a 2-up-1-down, two-track interleaved, Levitt procedure with an initial step-size of 8 JND's).
- ii.)* Record the subjects' response as to which vibration in the pair of stimuli **is preferred in terms of comfort**.
- iii.)* The previous steps are iterated until both sequences of the interleaved Levitt procedure converge (10 reversals for each track or a maximum of 50 trials).
- iv.)* The Levitt procedure trial history is saved (stimuli order (reference or alternative), alternative levels, step size, subject choice, convergence levels).

### ***B.6.2 Complete the reduced Kolich survey***

- i.)* The  $1.5 \text{ m/s}^2$  road vibration recording (discussed in Chapter 3) is reconstructed on the platform (one block of data with a vibration duration of 5 s).
- ii.)* Subjects are handed, and allowed to read through the reduced version of, Kolich's seat comfort questionnaire.
- iii.)* The subject is again exposed to the road vibration recording and subsequently asked to complete the reduced version of Kolich's ride comfort survey.

## ***B.7 Collect objective data for SEAT value calculation***

- i.)* Scale the road vibration recording (duration 5 s) to produce road vibration signals with unweighted r.m.s. values of  $1 \text{ m/s}^2$ ,  $1.5 \text{ m/s}^2$  and  $2 \text{ m/s}^2$ .

- ii.) Reconstruct the *road vibration recordings*, on the DSTF platform by estimating the input command signal from the FRF between the platform acceleration and input voltage.
- iii.) Record the vibration on the platform, seat top, seatback perpendicular and in-plane at each mentioned vibration magnitude.

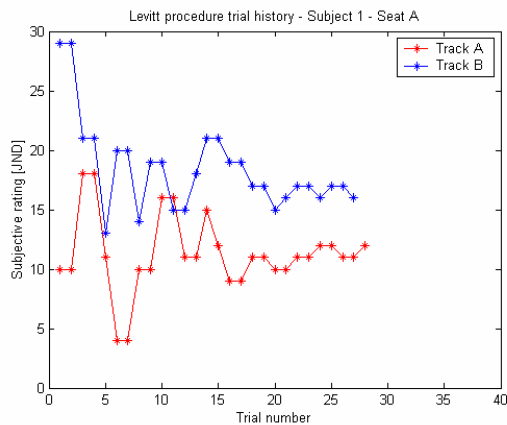
## ***B.8 End of test***



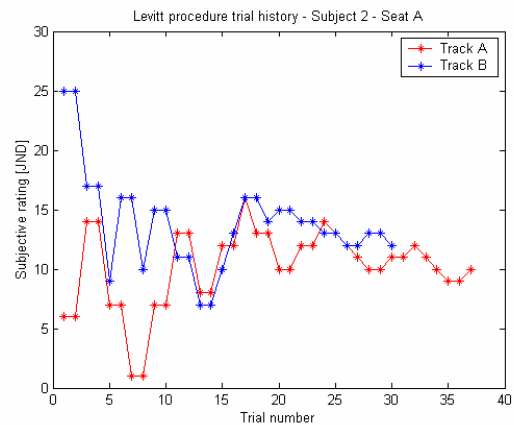
# APPENDIX C

## Levitt procedure trial histories

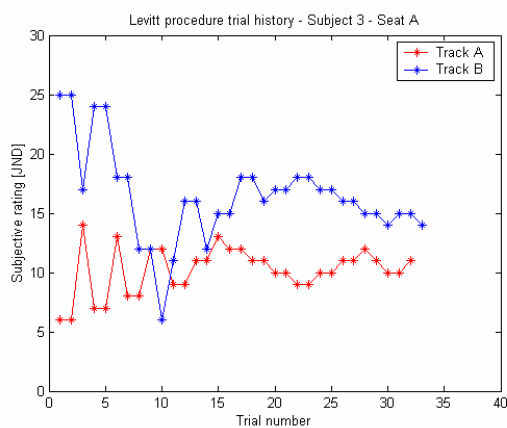
### C.1 Seat A



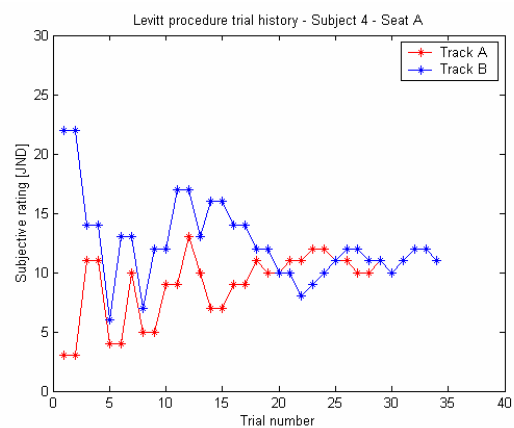
(a)



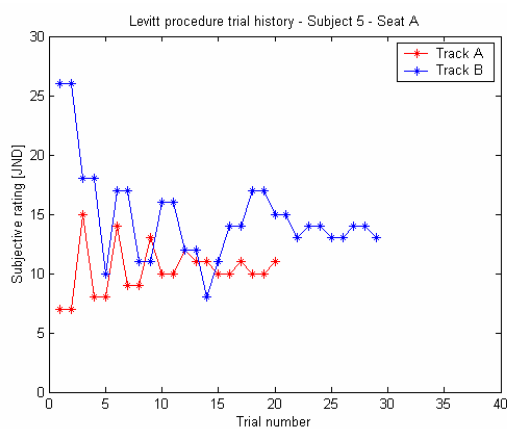
(b)



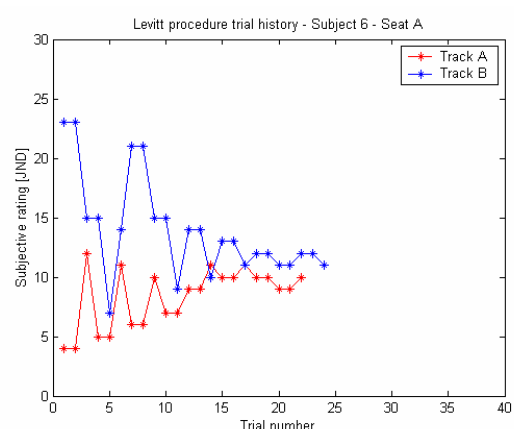
(c)



(d)



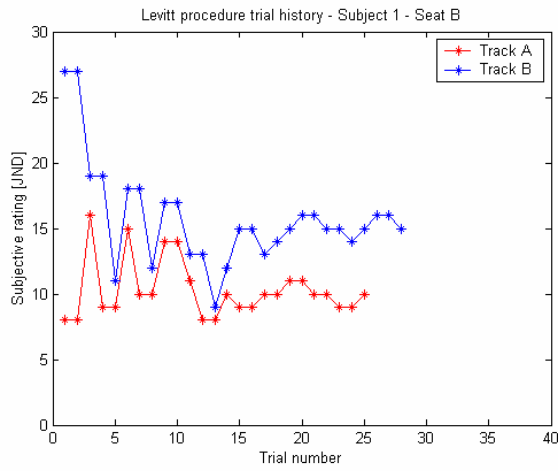
(e)



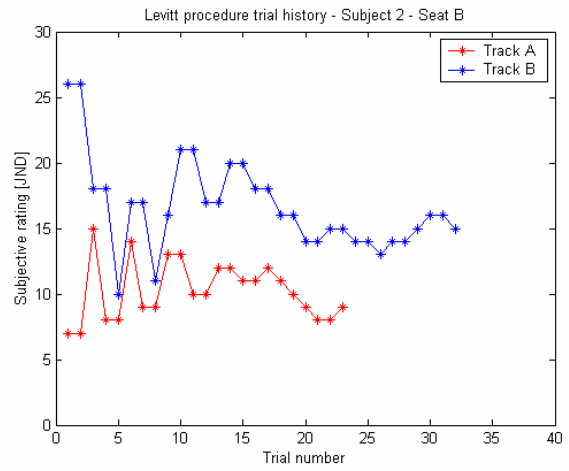
(f)

Figure C.1 2-up-1-down Levitt procedure trial histories for Subject (a) 1, (b) 2, (c) 3, (d) 4, (e) 5 and (f) 6 on Seat A

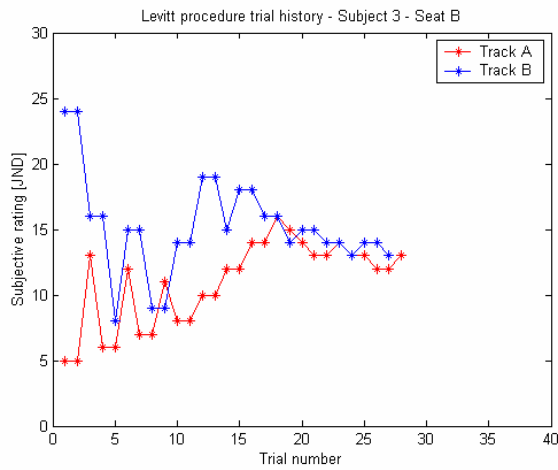
## C.2 Seat B



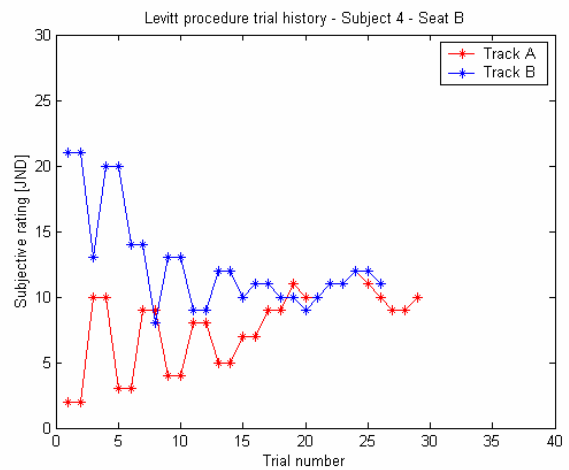
(a)



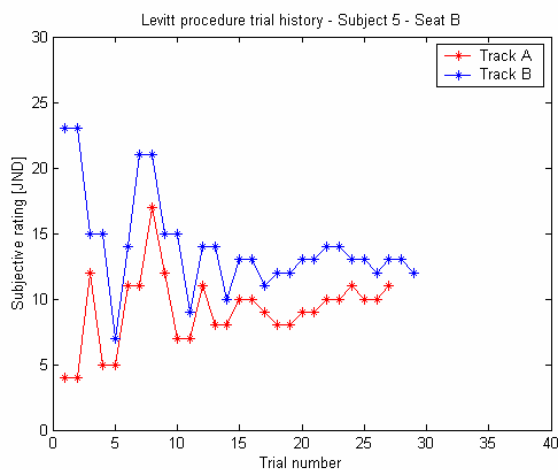
(b)



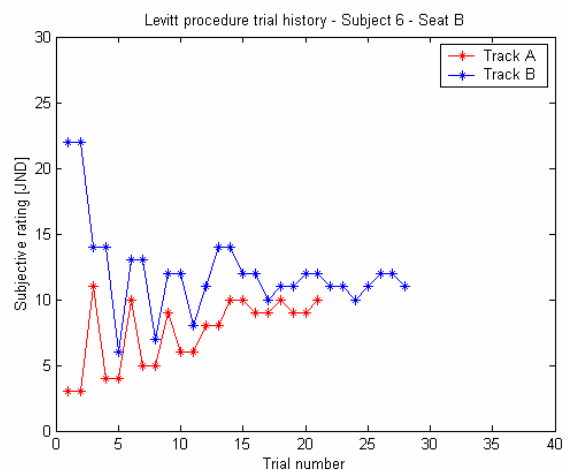
(c)



(d)



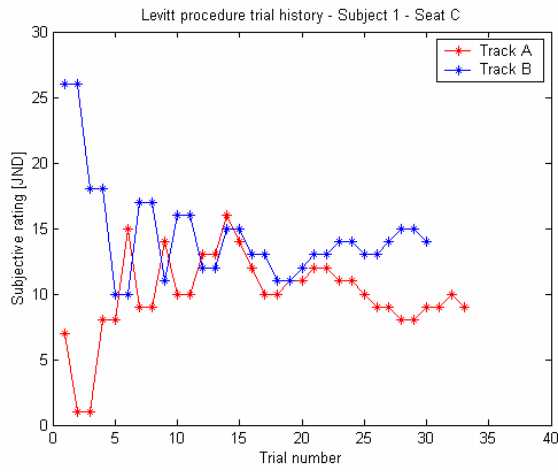
(e)



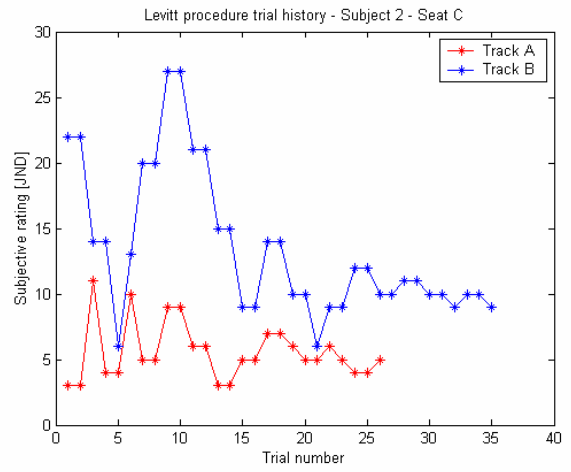
(f)

Figure C.2 2-up-1-down Levitt procedure trial histories for Subject (a) 1, (b) 2, (c) 3, (d) 4, (e) 5 and (f) 6 on Seat B

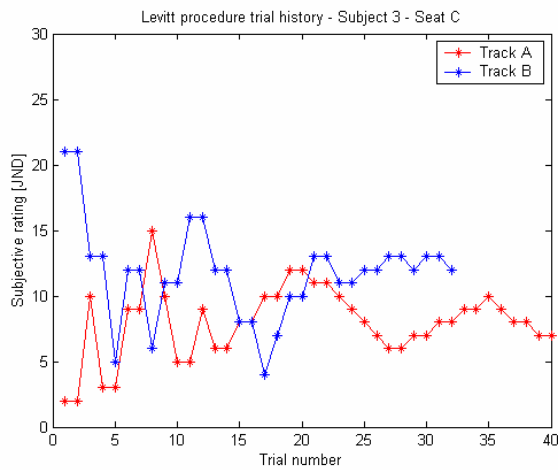
### C.3 Seat C



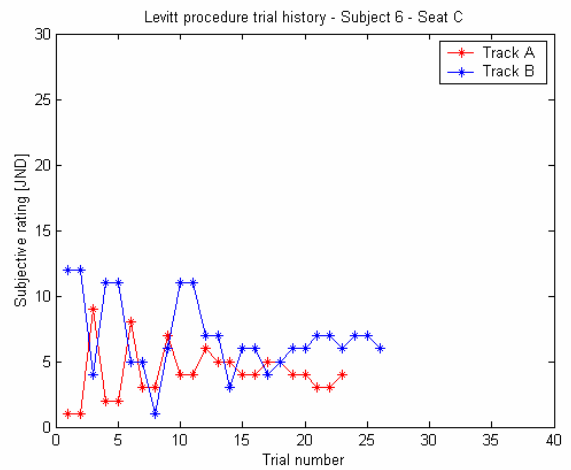
(a)



(b)



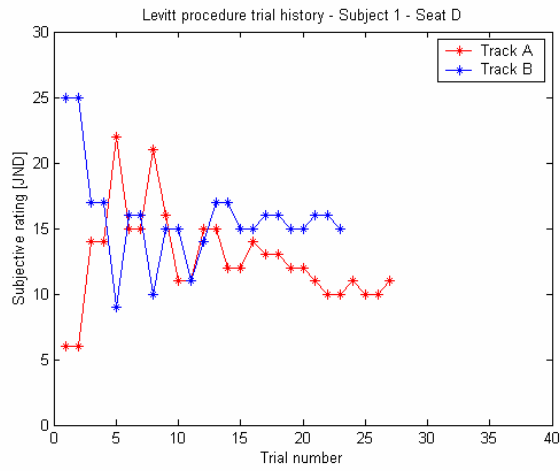
(c)



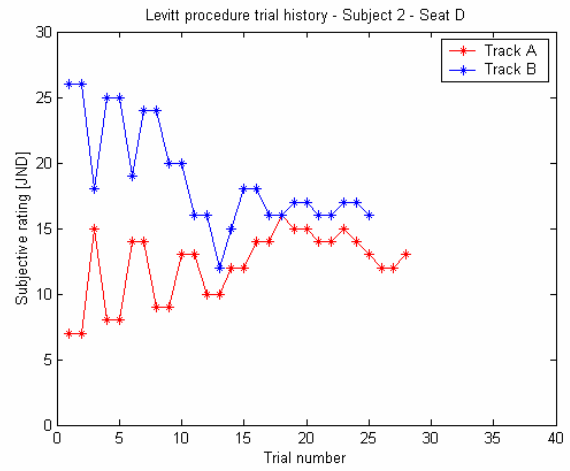
(d)

Figure C.3 2-up-1-down Levitt procedure trial histories for Subject (a) 1, (b) 2, (c) 3 and (d) 6 on Seat C

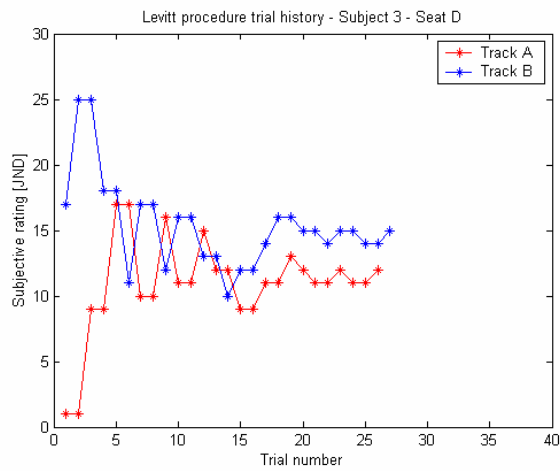
## C.4 Seat D



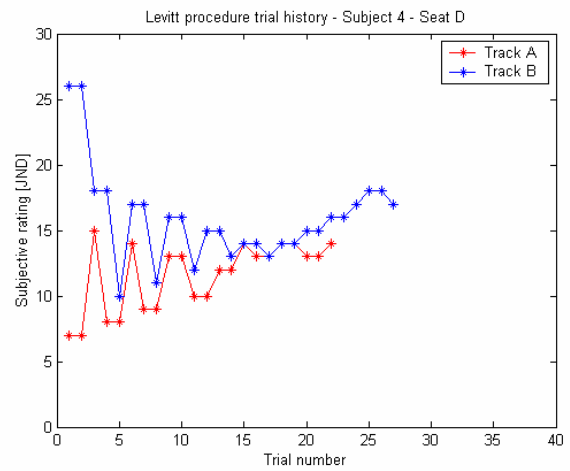
(a)



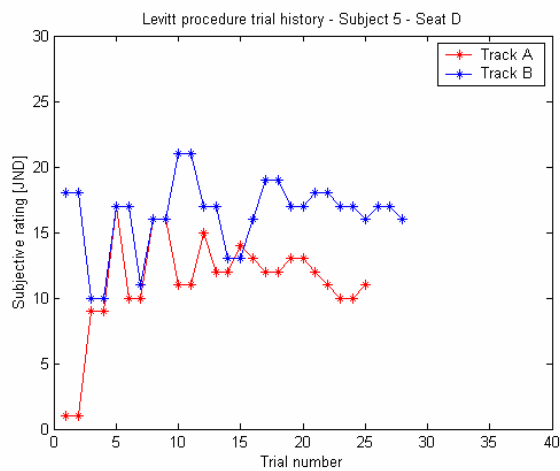
(b)



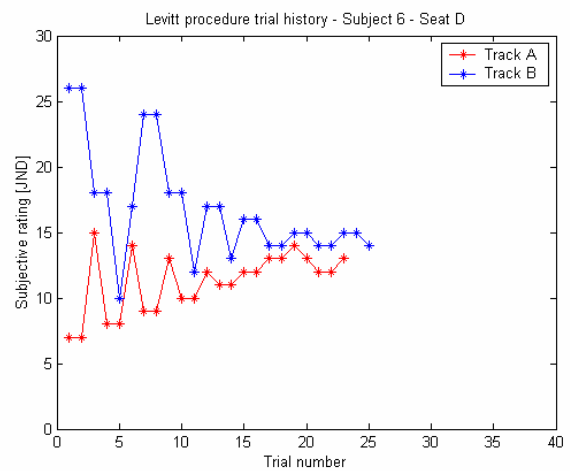
(c)



(d)



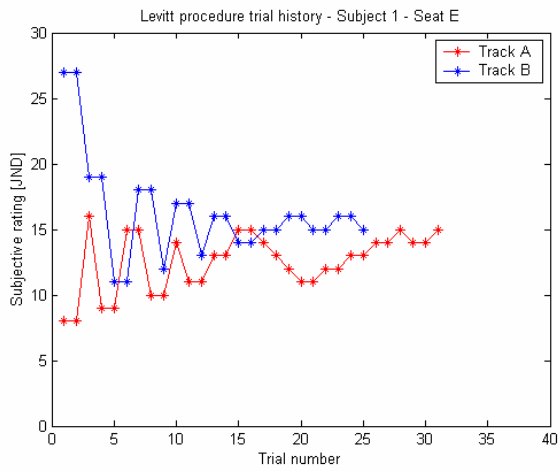
(e)



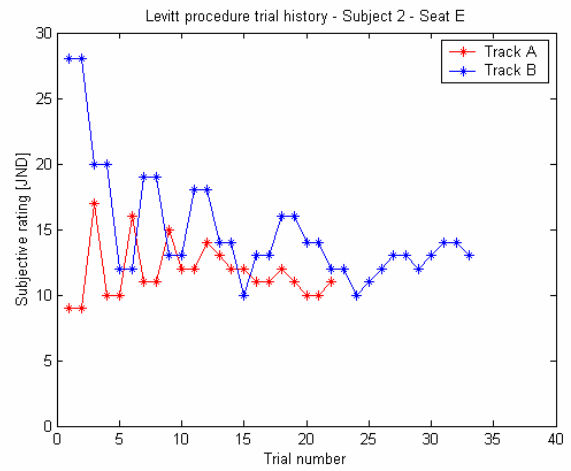
(f)

Figure C.4 2-up-1-down Levitt procedure trial histories for Subject (a) 1, (b) 2, (c) 3, (d) 4, (e) 5 and (f) 6 on Seat D

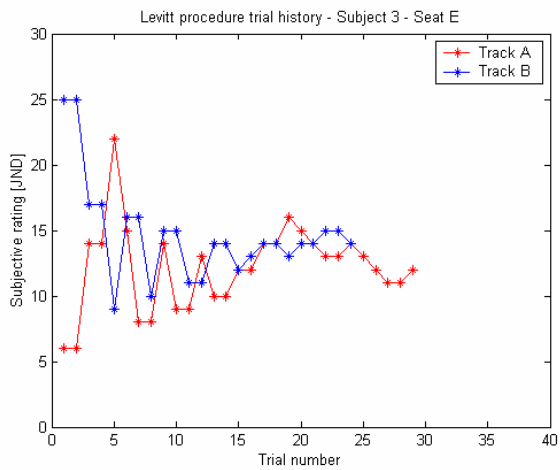
## C.5 Seat E



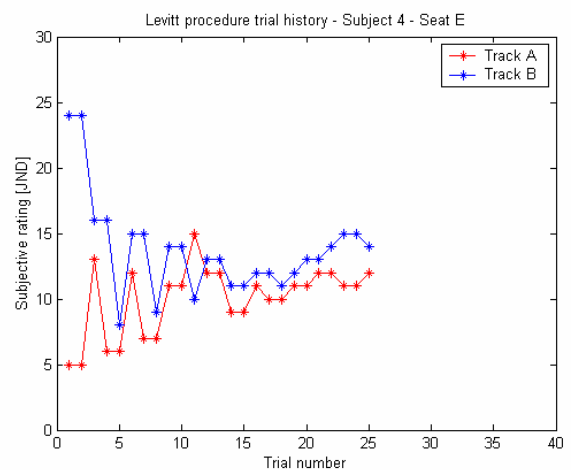
(a)



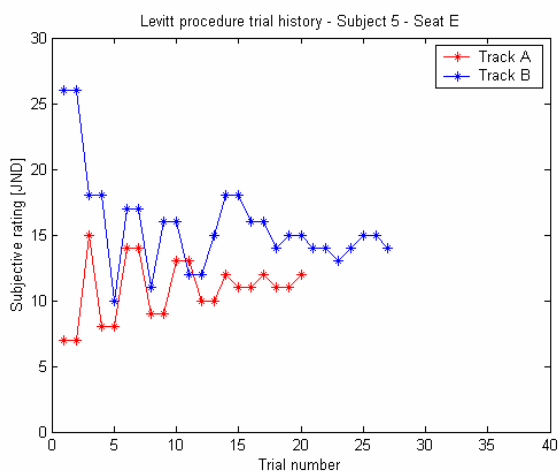
(b)



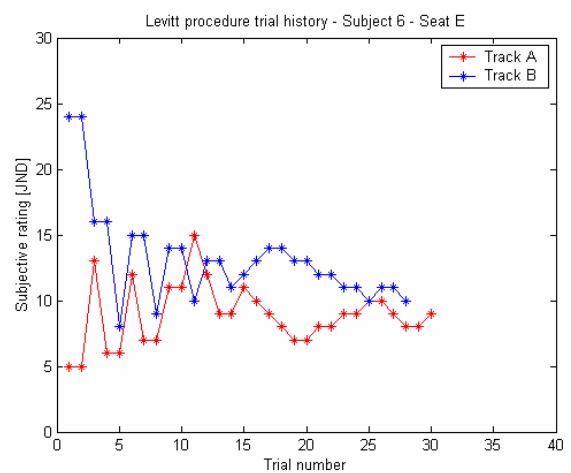
(c)



(d)



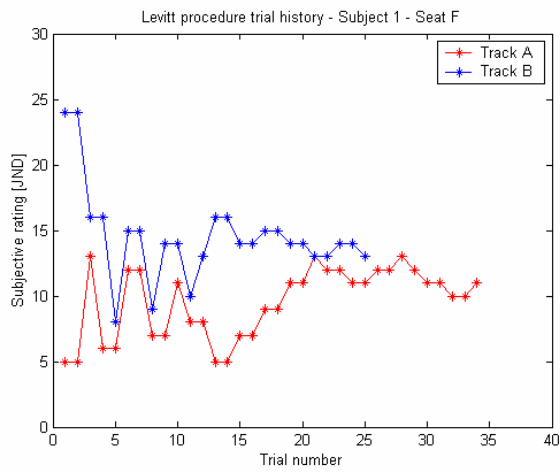
(e)



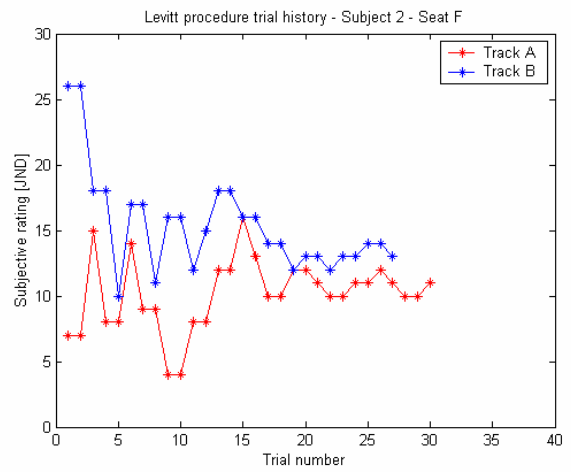
(f)

Figure C.5 2-up-1-down Levitt procedure trial histories for Subject (a) 1, (b) 2, (c) 3, (d) 4, (e) 5 and (f) 6 on Seat E

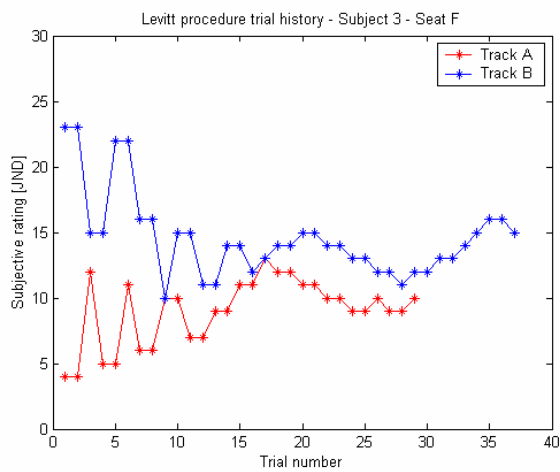
## C.6 Seat F



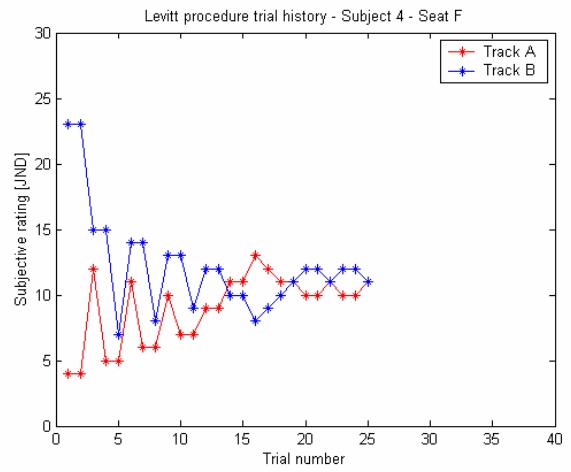
(a)



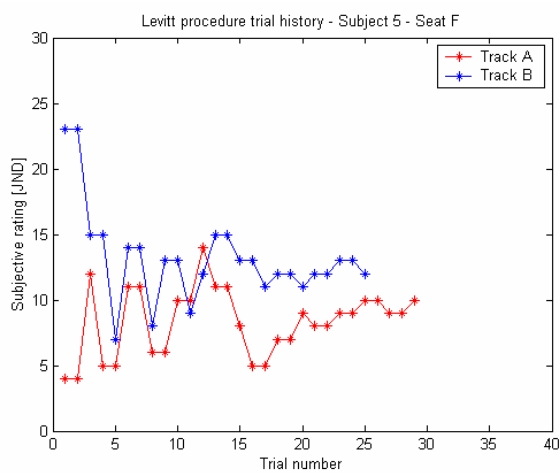
(b)



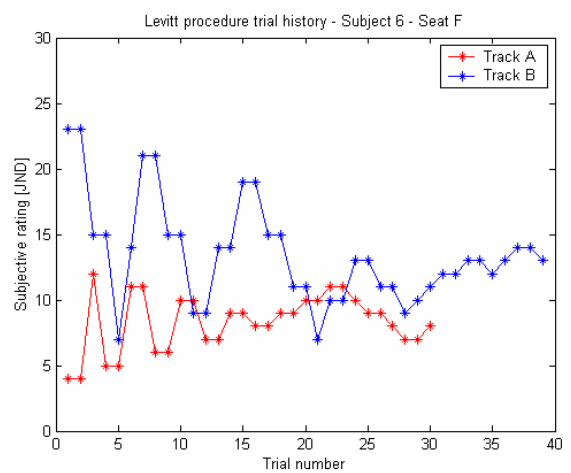
(c)



(d)



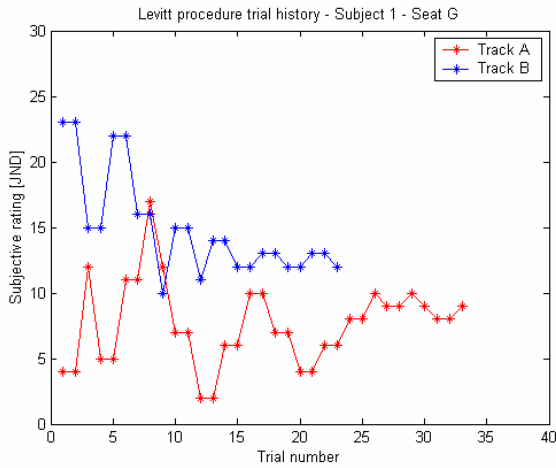
(e)



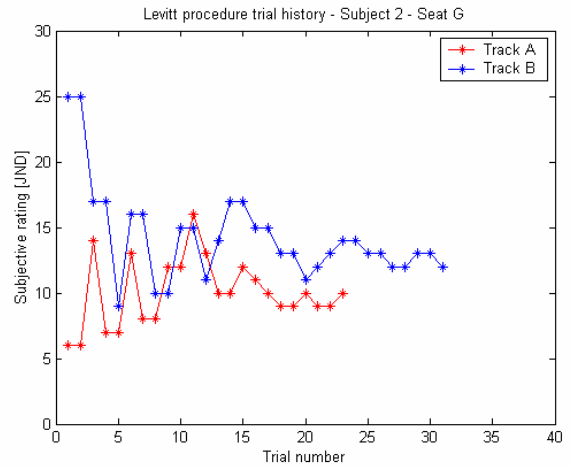
(f)

Figure C.6 2-up-1-down Levitt procedure trial histories for Subject (a) 1, (b) 2, (c) 3, (d) 4, (e) 5 and (f) 6 on Seat F

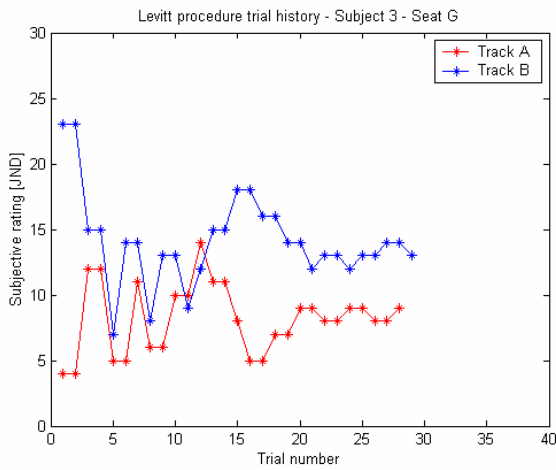
## C.7 Seat G



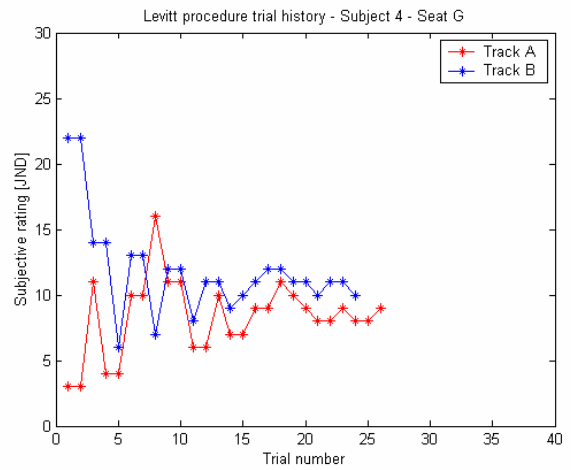
(a)



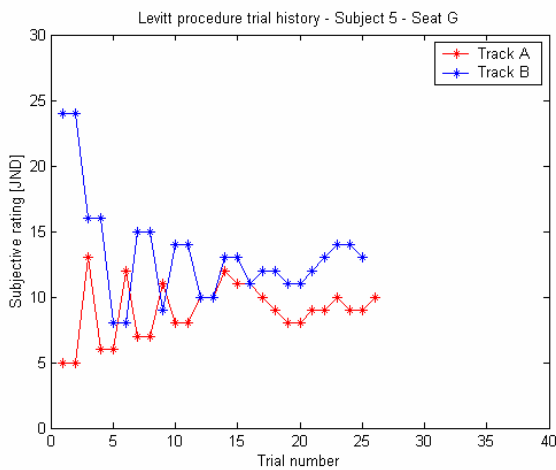
(b)



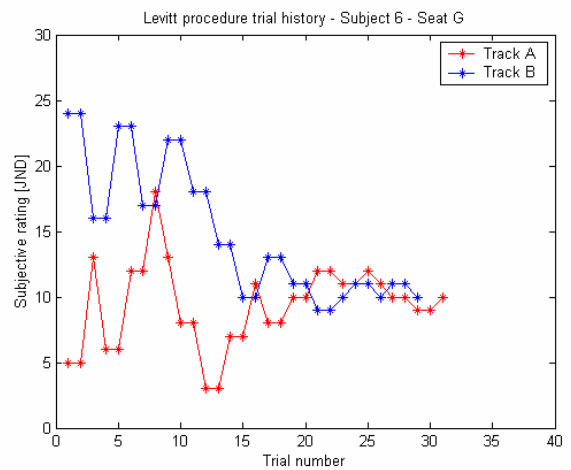
(c)



(d)



(e)



(f)

Figure C.7 2-up-1-down Levitt procedure trial histories for Subject (a) 1, (b) 2, (c) 3, (d) 4, (e) 5 and (f) 6 on Seat G

## APPENDIX D

# Acceleration r.m.s. values of data used for SEAT value calculation

**Table D.1 Acceleration r.m.s. values for Seat A**

<b>Seat A</b>		<i>Subject 1</i>	<i>Subject 2</i>	<i>Subject 3</i>	<i>Subject 4</i>	<i>Subject 5</i>	<i>Subject 6</i>	<i>Stdev</i>	<i>Avg</i>
$a_{z \text{ plat}}$	[m/s <sup>2</sup> ]	0.75	0.98	0.98	0.88	0.99	0.98	<b>0.10</b>	<b>0.93</b>
$a_{z_{w_k} \text{ plat}; k=1.0}$	[m/s <sup>2</sup> ]	0.57	0.73	0.72	0.65	0.73	0.72	<b>0.07</b>	<b>0.69</b>
$a_{z_{w_k} \text{ plat}; k=0.4}$	[m/s <sup>2</sup> ]	0.07	0.09	0.09	0.08	0.09	0.09	<b>0.01</b>	<b>0.08</b>
$a_{z_{w_c} \text{ plat}; k=0.8}$	[m/s <sup>2</sup> ]	0.28	0.46	0.45	0.41	0.46	0.46	<b>0.07</b>	<b>0.42</b>
$a_{z \text{ seat top}}$	[m/s <sup>2</sup> ]	0.82	0.75	0.75	0.61	0.71	0.64	<b>0.08</b>	<b>0.71</b>
$a_{z_{w_k} \text{ seat top}; k=1.0}$	[m/s <sup>2</sup> ]	0.62	0.57	0.58	0.45	0.52	0.47	<b>0.07</b>	<b>0.53</b>
$a_{z \text{ seatback in-plane}}$	[m/s <sup>2</sup> ]	0.96	0.99	0.97	0.86	0.86	0.97	<b>0.06</b>	<b>0.94</b>
$a_{z_{w_k} \text{ seatback in-plane}; k=0.4}$	[m/s <sup>2</sup> ]	0.09	0.09	0.09	0.08	0.08	0.09	<b>0.00</b>	<b>0.09</b>
$a_{z \text{ seatback perpendicular}}$	[m/s <sup>2</sup> ]	0.46	0.36	0.38	0.48	0.48	0.49	<b>0.06</b>	<b>0.44</b>
$a_{z_{w_c} \text{ seatback perpendicular}; k=0.8}$	[m/s <sup>2</sup> ]	0.22	0.21	0.22	0.28	0.28	0.29	<b>0.04</b>	<b>0.25</b>

**Table D.2 Acceleration r.m.s. values for Seat B**

<b>Seat B</b>		<i>Subject 1</i>	<i>Subject 2</i>	<i>Subject 3</i>	<i>Subject 4</i>	<i>Subject 5</i>	<i>Subject 6</i>	<i>Stdev</i>	<i>Avg</i>
$a_{z \text{ plat}}$	[m/s <sup>2</sup> ]	0.96	0.88	0.96	0.97	0.96	0.97	<b>0.04</b>	<b>0.95</b>
$a_{z_{w_k} \text{ plat}; k=1.0}$	[m/s <sup>2</sup> ]	0.71	0.65	0.72	0.77	0.71	0.73	<b>0.04</b>	<b>0.71</b>
$a_{z_{w_k} \text{ plat}; k=0.4}$	[m/s <sup>2</sup> ]	0.09	0.08	0.09	0.09	0.09	0.09	<b>0.00</b>	<b>0.09</b>
$a_{z_{w_c} \text{ plat}; k=0.8}$	[m/s <sup>2</sup> ]	0.45	0.41	0.45	0.48	0.45	0.45	<b>0.02</b>	<b>0.45</b>
$a_{z \text{ seat top}}$	[m/s <sup>2</sup> ]	0.76	0.65	0.87	0.64	0.67	0.64	<b>0.09</b>	<b>0.70</b>
$a_{z_{w_k} \text{ seat top}; k=1.0}$	[m/s <sup>2</sup> ]	0.56	0.48	0.67	0.48	0.50	0.48	<b>0.08</b>	<b>0.53</b>
$a_{z \text{ seatback in-plane}}$	[m/s <sup>2</sup> ]	0.98	0.90	0.92	0.90	0.96	0.99	<b>0.04</b>	<b>0.94</b>
$a_{z_{w_k} \text{ seatback in-plane}; k=0.4}$	[m/s <sup>2</sup> ]	0.08	0.08	0.09	0.09	0.08	0.09	<b>0.00</b>	<b>0.09</b>
$a_{z \text{ seatback perpendicular}}$	[m/s <sup>2</sup> ]	0.48	0.47	0.36	0.57	0.64	0.66	<b>0.11</b>	<b>0.53</b>
$a_{z_{w_c} \text{ seatback perpendicular}; k=0.8}$	[m/s <sup>2</sup> ]	0.28	0.29	0.22	0.34	0.37	0.39	<b>0.06</b>	<b>0.31</b>



**Table D.3 Acceleration r.m.s. values for Seat C**

<b>Seat C</b>		<i>Subject 1</i>	<i>Subject 2</i>	<i>Subject 3</i>	<i>Subject 4</i>	<i>Subject 5</i>	<i>Subject 6</i>	<i>Stdev</i>	<i>Avg</i>
$a_{z \text{ plat}}$	[m/s <sup>2</sup> ]	0.92	0.97	0.95	**	**	0.96	<b>0.02</b>	<b>0.95</b>
$a_{z w_k \text{ plat}; k=1.0}$	[m/s <sup>2</sup> ]	0.73	0.73	0.75	**	**	0.76	<b>0.02</b>	<b>0.74</b>
$a_{z w_k \text{ plat}; k=0.4}$	[m/s <sup>2</sup> ]	0.08	0.09	0.09	**	**	0.09	<b>0.00</b>	<b>0.09</b>
$a_{z w_c \text{ plat}; k=0.8}$	[m/s <sup>2</sup> ]	0.45	0.46	0.46	**	**	0.47	<b>0.01</b>	<b>0.46</b>
$a_{z \text{ seat top}}$	[m/s <sup>2</sup> ]	0.76	0.62	0.58	**	**	0.40	<b>0.15</b>	<b>0.59</b>
$a_{z w_k \text{ seat top}; k=1.0}$	[m/s <sup>2</sup> ]	0.58	0.45	0.43	**	**	0.26	<b>0.13</b>	<b>0.43</b>
$a_{z \text{ seatback in-plane}}$	[m/s <sup>2</sup> ]	0.97	0.83	0.71	**	**	0.50	<b>0.20</b>	<b>0.75</b>
$a_{z w_k \text{ seatback in-plane}; k=0.4}$	[m/s <sup>2</sup> ]	0.10	0.08	0.08	**	**	0.08	<b>0.01</b>	<b>0.09</b>
$a_{z \text{ seatback perpendicular}}$	[m/s <sup>2</sup> ]	0.47	0.33	0.28	**	**	0.31	<b>0.08</b>	<b>0.35</b>
$a_{z w_c \text{ seatback perpendicular}; k=0.8}$	[m/s <sup>2</sup> ]	0.27	0.19	0.16	**	**	0.17	<b>0.05</b>	<b>0.20</b>

\*\* The reference signal could not be reproduced within 10% accuracy

**Table D.4 Acceleration r.m.s. values for Seat D**

<b>Seat D</b>		<i>Subject 1</i>	<i>Subject 2</i>	<i>Subject 3</i>	<i>Subject 4</i>	<i>Subject 5</i>	<i>Subject 6</i>	<i>Stdev</i>	<i>Avg</i>
$a_{z \text{ plat}}$	[m/s <sup>2</sup> ]	0.94	0.92	0.96	0.96	0.98	0.99	<b>0.03</b>	<b>0.96</b>
$a_{z w_k \text{ plat}; k=1.0}$	[m/s <sup>2</sup> ]	0.76	0.72	0.77	0.75	1.02	0.76	<b>0.11</b>	<b>0.80</b>
$a_{z w_k \text{ plat}; k=0.4}$	[m/s <sup>2</sup> ]	0.09	0.08	0.09	0.09	0.09	0.09	<b>0.00</b>	<b>0.09</b>
$a_{z w_c \text{ plat}; k=0.8}$	[m/s <sup>2</sup> ]	0.47	0.44	0.47	0.47	0.41	0.47	<b>0.02</b>	<b>0.46</b>
$a_{z \text{ seat top}}$	[m/s <sup>2</sup> ]	0.86	0.86	0.86	0.94	0.91	0.88	<b>0.03</b>	<b>0.89</b>
$a_{z w_k \text{ seat top}; k=1.0}$	[m/s <sup>2</sup> ]	0.66	0.65	0.67	0.73	0.94	0.67	<b>0.11</b>	<b>0.72</b>
$a_{z \text{ seatback in-plane}}$	[m/s <sup>2</sup> ]	0.86	0.86	0.96	0.94	0.89	0.93	<b>0.04</b>	<b>0.90</b>
$a_{z w_k \text{ seatback in-plane}; k=0.4}$	[m/s <sup>2</sup> ]	0.09	0.09	0.09	0.09	0.93	0.09	<b>0.34</b>	<b>0.23</b>
$a_{z \text{ seatback perpendicular}}$	[m/s <sup>2</sup> ]	0.38	0.27	0.29	0.51	0.43	0.59	<b>0.12</b>	<b>0.41</b>
$a_{z w_c \text{ seatback perpendicular}; k=0.8}$	[m/s <sup>2</sup> ]	0.20	0.14	0.15	0.27	0.28	0.31	<b>0.07</b>	<b>0.22</b>

**Table D.5 Acceleration r.m.s. values for Seat E**

<b>Seat E</b>		<i>Subject 1</i>	<i>Subject 2</i>	<i>Subject 3</i>	<i>Subject 4</i>	<i>Subject 5</i>	<i>Subject 6</i>	<i>Stdev</i>	<i>Avg</i>
$a_{z \text{ plat}}$	[m/s <sup>2</sup> ]	0.97	0.98	0.96	0.91	0.97	0.95	<b>0.02</b>	<b>0.96</b>
$a_{z w_k \text{ plat}; k=1.0}$	[m/s <sup>2</sup> ]	0.73	0.74	0.72	0.72	0.76	0.71	<b>0.02</b>	<b>0.73</b>
$a_{z w_k \text{ plat}; k=0.4}$	[m/s <sup>2</sup> ]	0.09	0.09	0.09	0.09	0.09	0.09	<b>0.00</b>	<b>0.09</b>
$a_{z w_c \text{ plat}; k=0.8}$	[m/s <sup>2</sup> ]	0.45	0.46	0.45	0.45	0.47	0.45	<b>0.01</b>	<b>0.45</b>
$a_{z \text{ seat top}}$	[m/s <sup>2</sup> ]	0.91	1.14	0.84	0.74	0.82	0.72	<b>0.15</b>	<b>0.86</b>
$a_{z w_k \text{ seat top}; k=1.0}$	[m/s <sup>2</sup> ]	0.69	0.83	0.63	0.55	0.61	0.53	<b>0.11</b>	<b>0.64</b>
$a_{z \text{ seatback in-plane}}$	[m/s <sup>2</sup> ]	0.92	0.99	0.99	0.96	0.99	0.96	<b>0.03</b>	<b>0.97</b>
$a_{z w_k \text{ seatback in-plane}; k=0.4}$	[m/s <sup>2</sup> ]	0.08	0.09	0.09	0.09	0.09	0.08	<b>0.00</b>	<b>0.09</b>
$a_{z \text{ seatback perpendicular}}$	[m/s <sup>2</sup> ]	0.53	0.48	0.31	0.52	0.63	0.61	<b>0.11</b>	<b>0.51</b>
$a_{z w_c \text{ seatback perpendicular}; k=0.8}$	[m/s <sup>2</sup> ]	0.29	0.27	0.18	0.31	0.35	0.35	<b>0.06</b>	<b>0.29</b>

**Table D.6 Acceleration r.m.s. values for Seat F**

<b>Seat F</b>		<i>Subject 1</i>	<i>Subject 2</i>	<i>Subject 3</i>	<i>Subject 4</i>	<i>Subject 5</i>	<i>Subject 6</i>	<i>Stdev</i>	<i>Avg</i>
$a_{z \text{ plat}}$	[m/s <sup>2</sup> ]	0.99	0.98	1.26	0.96	0.96	0.92	<b>0.12</b>	<b>1.01</b>
$a_{z w_k \text{ plat}; k=1.0}$	[m/s <sup>2</sup> ]	0.76	0.75	0.96	0.71	0.72	0.65	<b>0.11</b>	<b>0.76</b>
$a_{z w_k \text{ plat}; k=0.4}$	[m/s <sup>2</sup> ]	0.09	0.09	0.11	0.09	0.09	0.09	<b>0.01</b>	<b>0.09</b>
$a_{z w_c \text{ plat}; k=0.8}$	[m/s <sup>2</sup> ]	0.47	0.46	0.60	0.45	0.45	0.44	<b>0.06</b>	<b>0.48</b>
$a_{z \text{ seat top}}$	[m/s <sup>2</sup> ]	0.70	0.84	1.02	0.62	0.67	0.70	<b>0.15</b>	<b>0.76</b>
$a_{z w_k \text{ seat top}; k=1.0}$	[m/s <sup>2</sup> ]	0.53	0.63	0.77	0.46	0.49	0.47	<b>0.12</b>	<b>0.56</b>
$a_{z \text{ seatback in-plane}}$	[m/s <sup>2</sup> ]	0.97	0.94	1.17	0.99	0.93	0.95	<b>0.09</b>	<b>0.99</b>
$a_{z w_k \text{ seatback in-plane}; k=0.4}$	[m/s <sup>2</sup> ]	0.09	0.09	0.11	0.09	0.09	0.09	<b>0.01</b>	<b>0.09</b>
$a_{z \text{ seatback perpendicular}}$	[m/s <sup>2</sup> ]	0.47	0.48	0.42	0.45	0.44	0.32	<b>0.06</b>	<b>0.43</b>
$a_{z w_c \text{ seatback perpendicular}; k=0.8}$	[m/s <sup>2</sup> ]	0.27	0.28	0.26	0.27	0.25	0.19	<b>0.03</b>	<b>0.25</b>

**Table D.7 Acceleration r.m.s. values for Seat G**

<b>Seat G</b>		<i>Subject 1</i>	<i>Subject 2</i>	<i>Subject 3</i>	<i>Subject 4</i>	<i>Subject 5</i>	<i>Subject 6</i>	<i>Stdev</i>	<i>Avg</i>
$a_{z \text{ plat}}$	[m/s <sup>2</sup> ]	1.00	0.99	1.42	0.90	0.97	0.96	<b>0.19</b>	<b>1.04</b>
$a_{z w_k \text{ plat}; k=1.0}$	[m/s <sup>2</sup> ]	0.77	0.72	1.06	0.66	0.72	0.71	<b>0.14</b>	<b>0.78</b>
$a_{z w_k \text{ plat}; k=0.4}$	[m/s <sup>2</sup> ]	0.09	0.09	0.12	0.08	0.09	0.09	<b>0.01</b>	<b>0.09</b>
$a_{z w_c \text{ plat}; k=0.8}$	[m/s <sup>2</sup> ]	0.48	0.46	0.66	0.42	0.45	0.45	<b>0.09</b>	<b>0.49</b>
$a_{z \text{ seat top}}$	[m/s <sup>2</sup> ]	0.74	0.74	1.04	0.61	0.64	0.59	<b>0.17</b>	<b>0.73</b>
$a_{z w_k \text{ seat top}; k=1.0}$	[m/s <sup>2</sup> ]	0.58	0.55	0.79	0.45	0.47	0.43	<b>0.13</b>	<b>0.54</b>
$a_{z \text{ seatback in-plane}}$	[m/s <sup>2</sup> ]	1.00	1.02	1.42	0.87	0.96	0.99	<b>0.19</b>	<b>1.05</b>
$a_{z w_k \text{ seatback in-plane}; k=0.4}$	[m/s <sup>2</sup> ]	0.09	0.09	0.12	0.08	0.09	0.09	<b>0.01</b>	<b>0.09</b>
$a_{z \text{ seatback perpendicular}}$	[m/s <sup>2</sup> ]	0.43	0.40	0.43	0.41	0.47	0.32	<b>0.05</b>	<b>0.41</b>
$a_{z w_c \text{ seatback perpendicular}; k=0.8}$	[m/s <sup>2</sup> ]	0.25	0.24	0.26	0.25	0.27	0.19	<b>0.03</b>	<b>0.24</b>

# APPENDIX E

## Seat transmissibility measurements

### E.1 Seat A

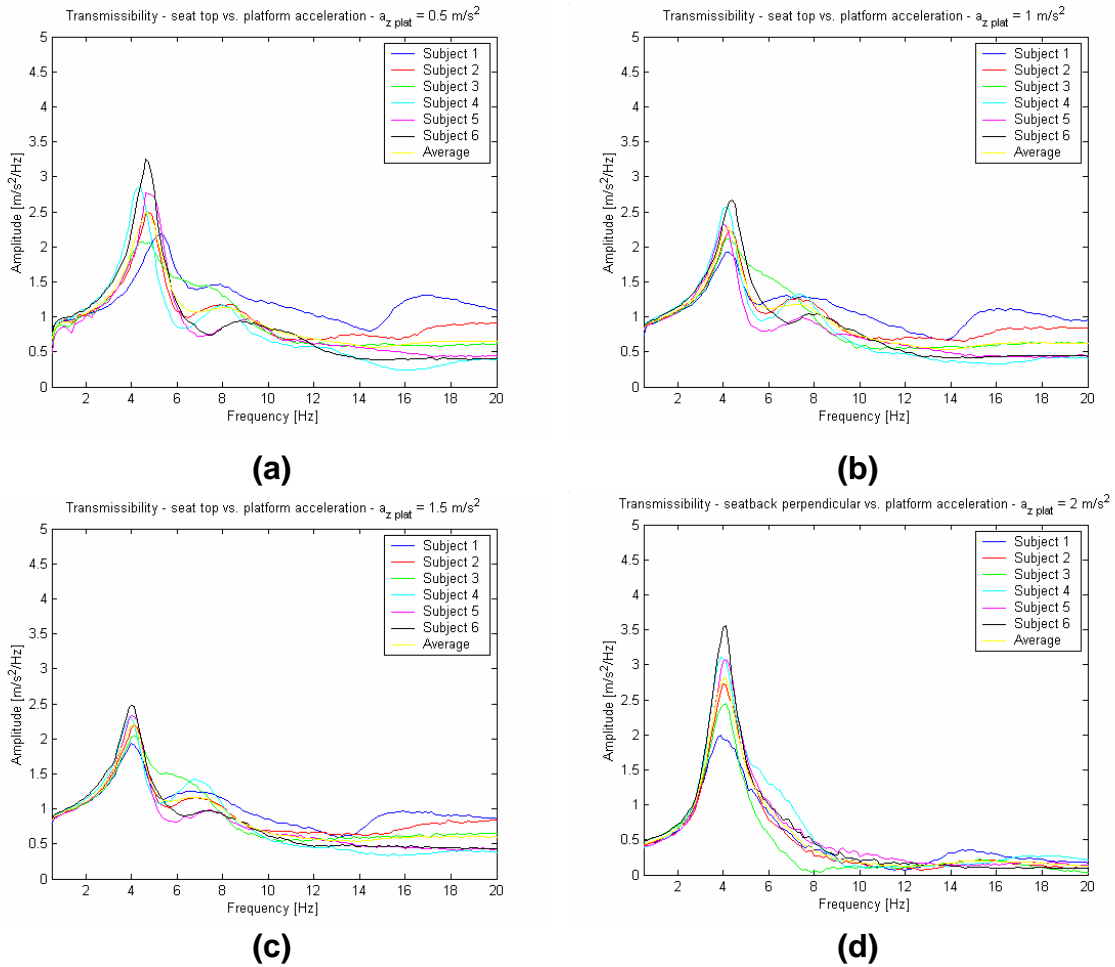
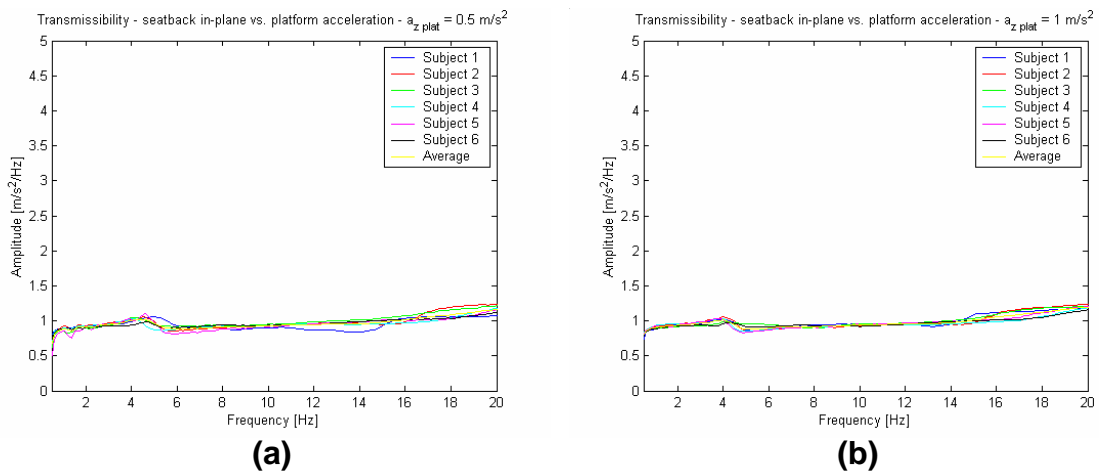
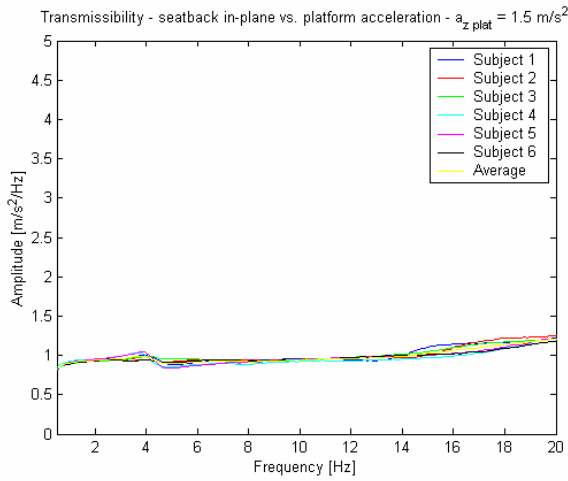
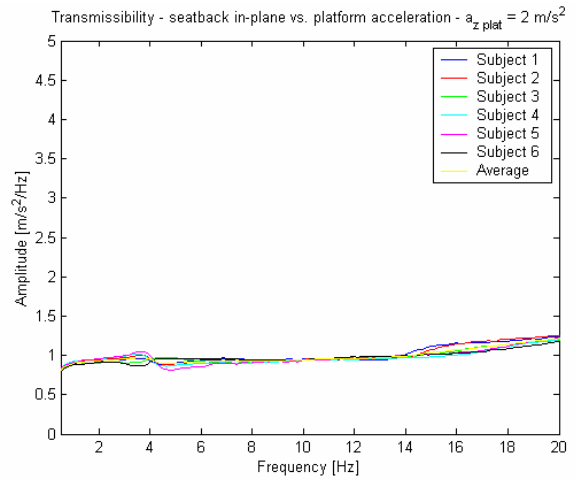


Figure E.1 Seat top transmissibility of Seat A at (a)  $0.5 \text{ m/s}^2$ , (b)  $1 \text{ m/s}^2$ , (c)  $1.5 \text{ m/s}^2$  and (d)  $2 \text{ m/s}^2$



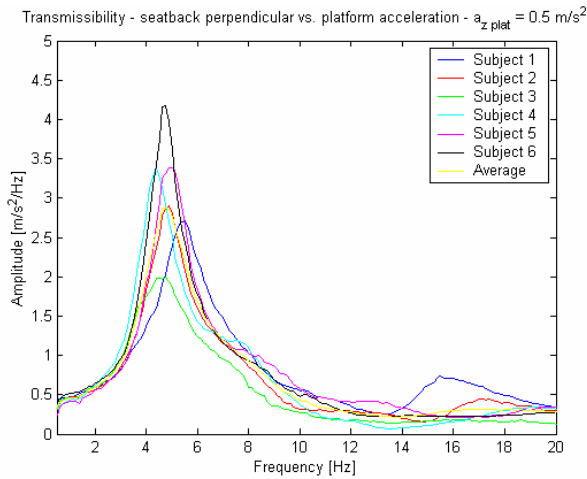


(c)

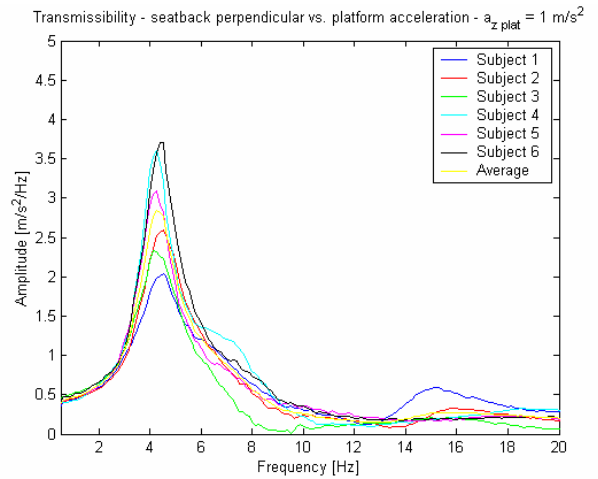


(d)

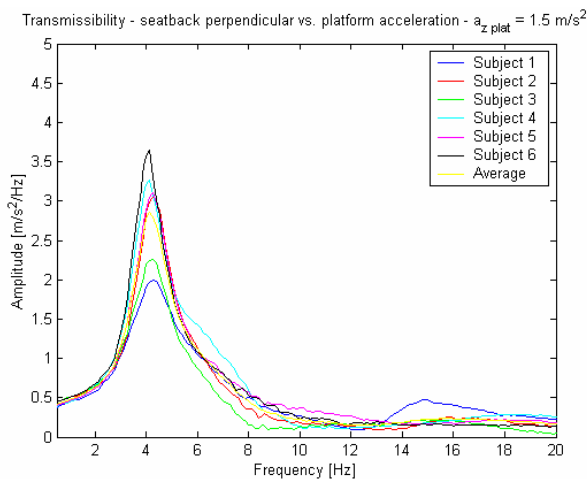
**Figure E.2 Seatback in-plane transmissibility of Seat A at (a) 0.5 m/s<sup>2</sup>, (b) 1 m/s<sup>2</sup>, (c) 1.5 m/s<sup>2</sup> and (d) 2 m/s<sup>2</sup>**



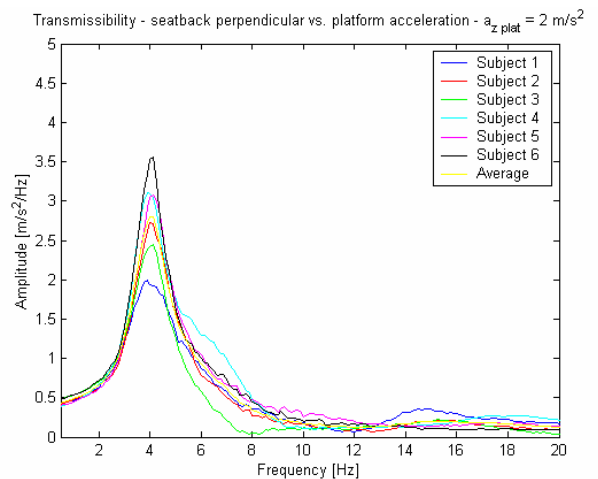
(a)



(b)



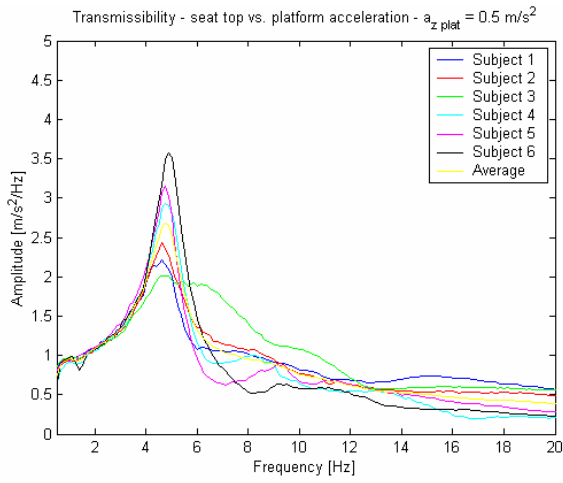
(c)



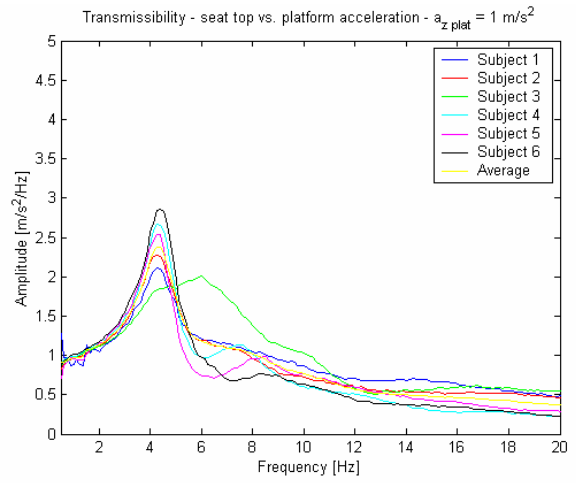
(d)

**Figure E.3 Seatback perpendicular transmissibility of Seat A at (a) 0.5 m/s<sup>2</sup>, (b) 1 m/s<sup>2</sup>, (c) 1.5 m/s<sup>2</sup> and (d) 2 m/s<sup>2</sup>**

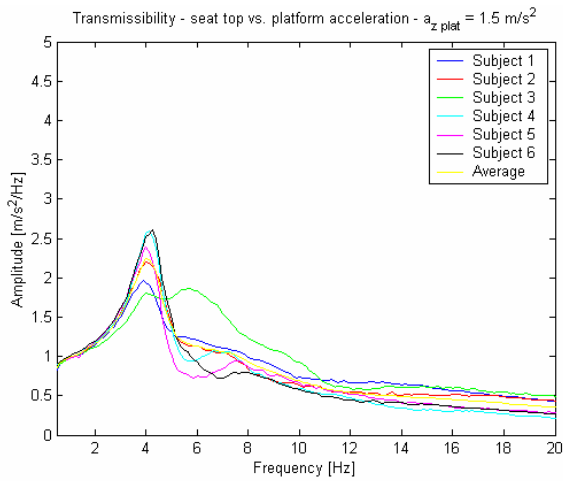
## E.2 Seat B



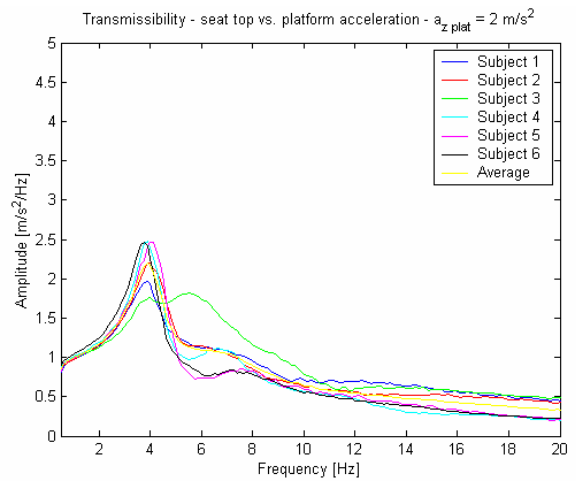
(a)



(b)

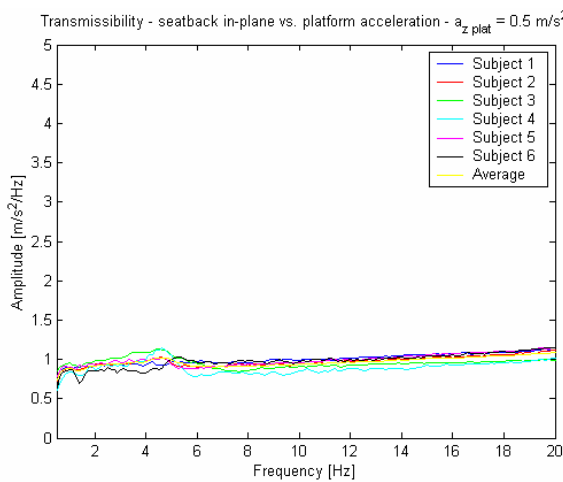


(c)

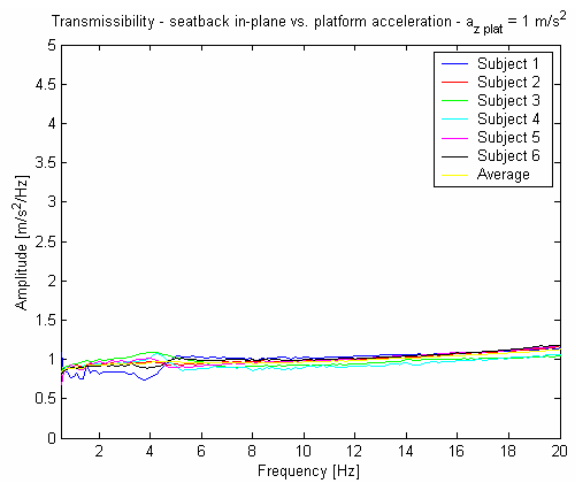


(d)

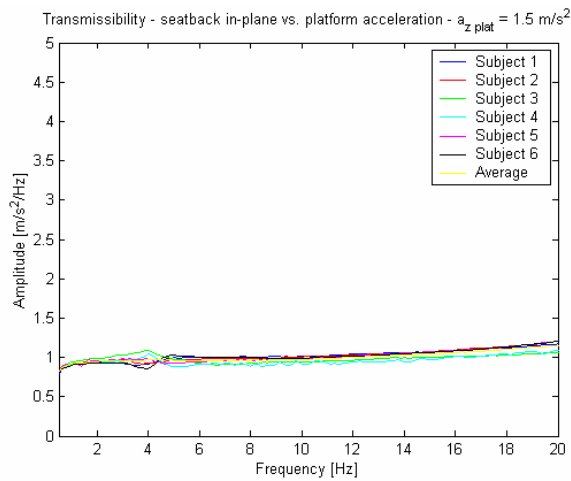
**Figure E.4 Seat top transmissibility of Seat B at (a)  $0.5 \text{ m/s}^2$ , (b)  $1 \text{ m/s}^2$ , (c)  $1.5 \text{ m/s}^2$  and (d)  $2 \text{ m/s}^2$**



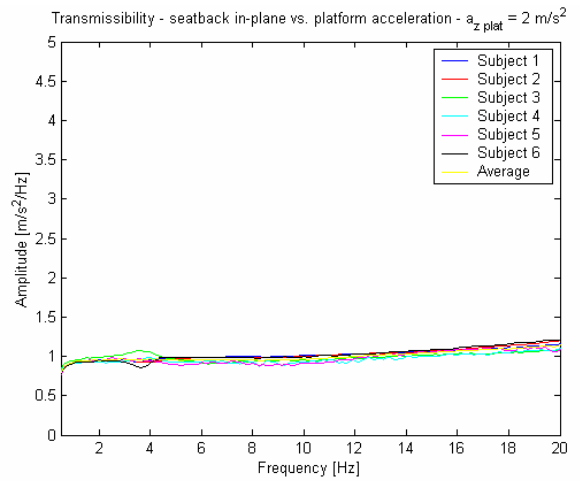
(a)



(b)

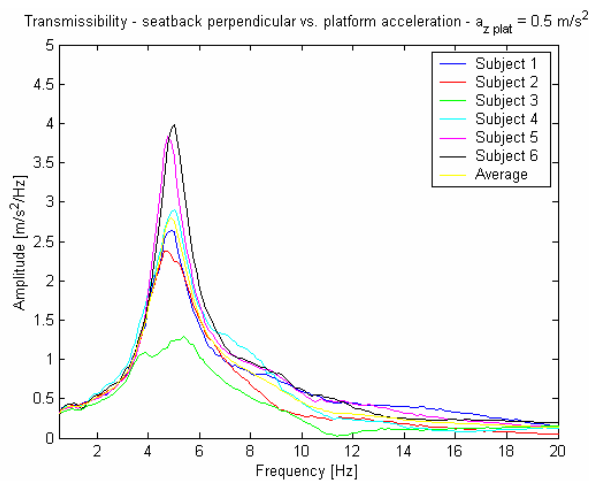


(c)

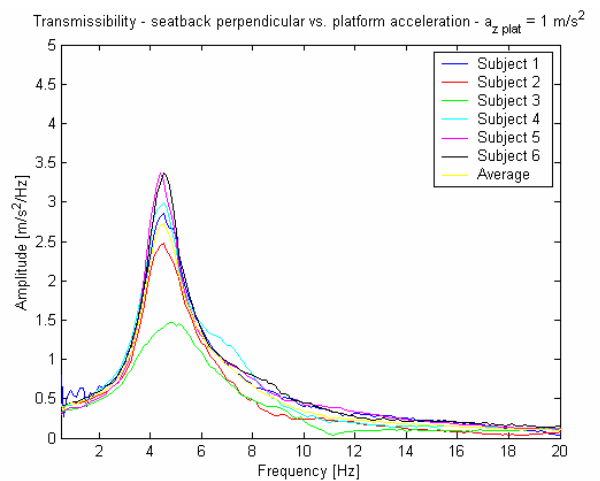


(d)

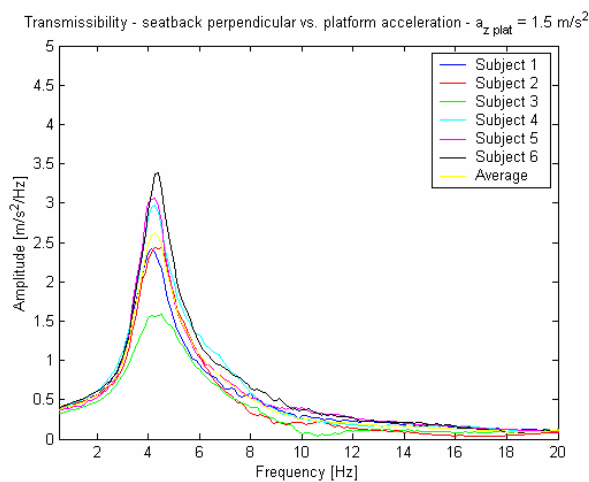
**Figure E.5 Seatback in-plane transmissibility of Seat B at (a) 0.5 m/s<sup>2</sup>, (b) 1 m/s<sup>2</sup>, (c) 1.5 m/s<sup>2</sup> and (d) 2 m/s<sup>2</sup>**



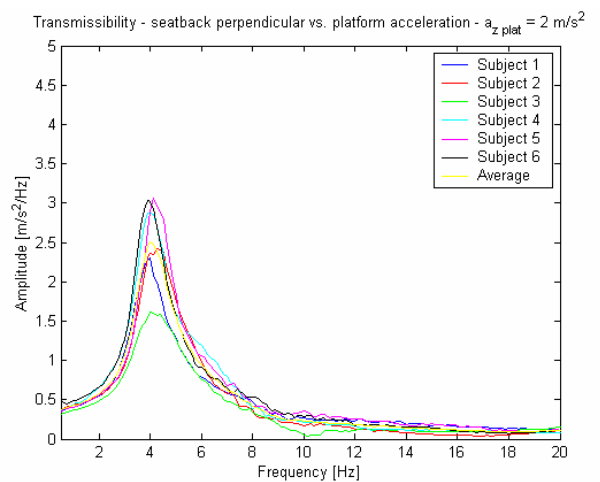
(a)



(b)



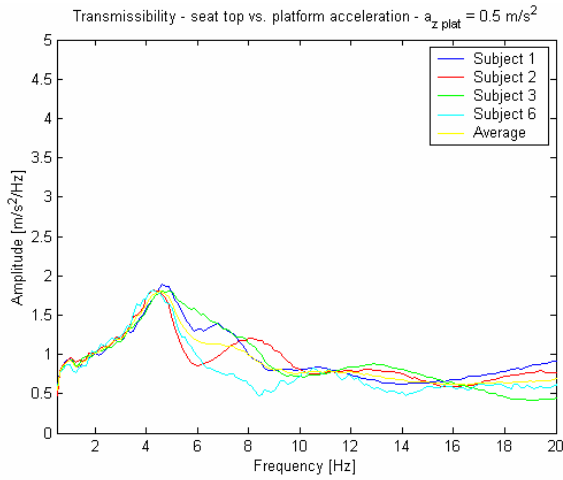
(c)



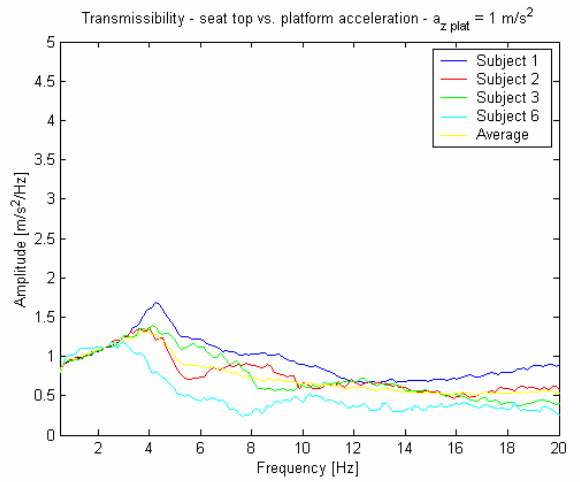
(d)

**Figure E.6 Seatback perpendicular transmissibility of Seat B at (a) 0.5 m/s<sup>2</sup>, (b) 1 m/s<sup>2</sup>, (c) 1.5 m/s<sup>2</sup> and (d) 2 m/s<sup>2</sup>**

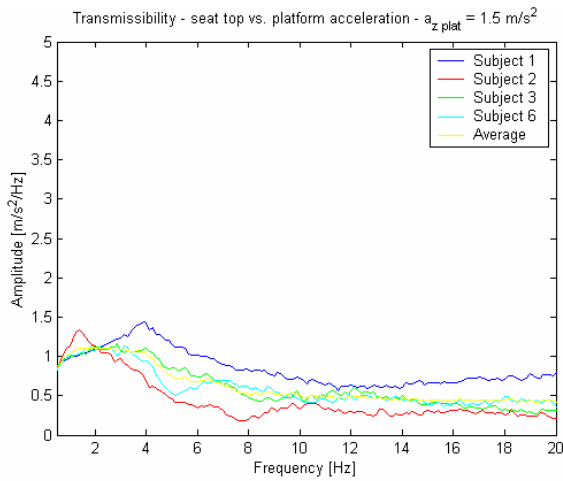
## E.3 Seat C



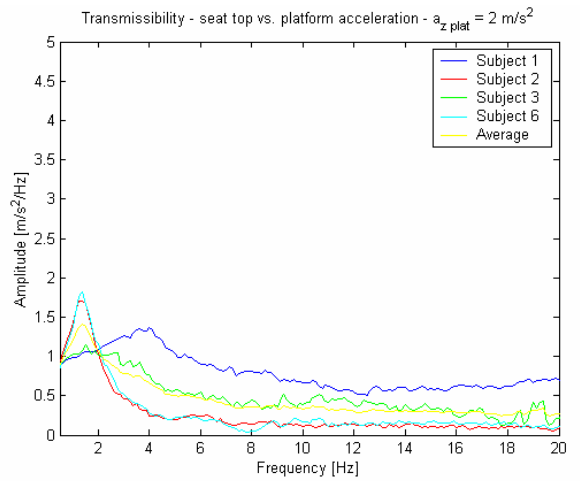
(a)



(b)

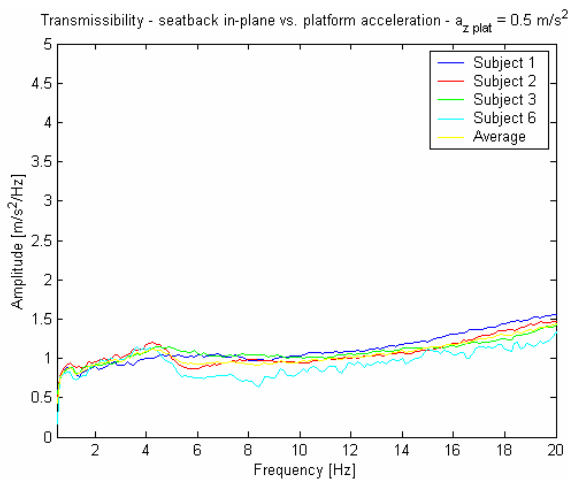


(c)

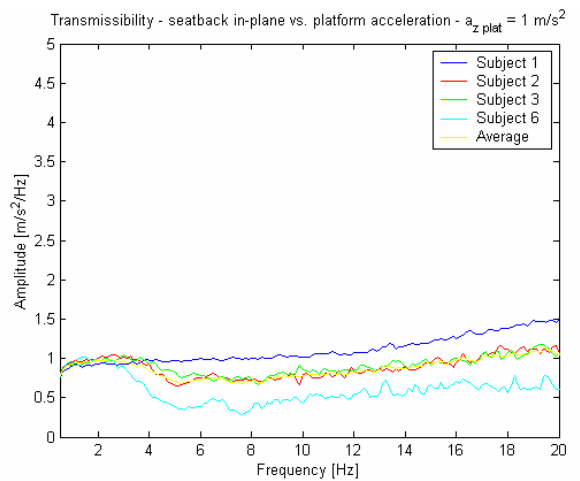


(d)

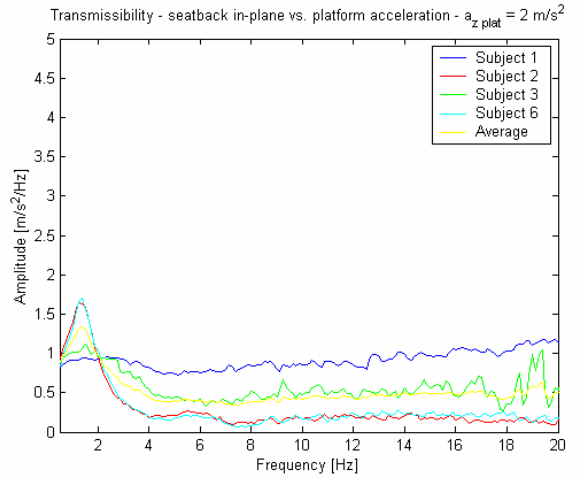
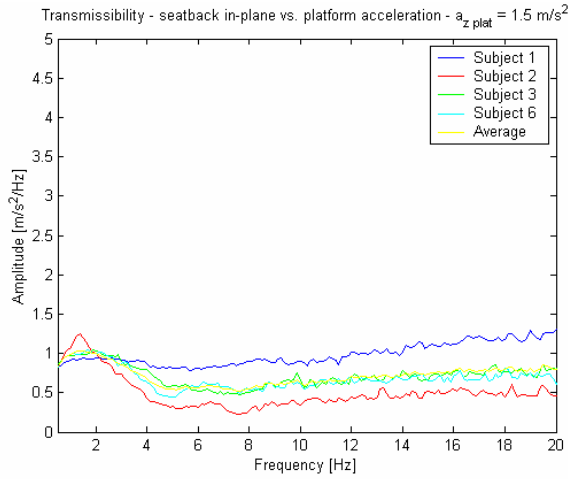
**Figure E.7 Seat top transmissibility of Seat C at (a)  $0.5 \text{ m/s}^2$ , (b)  $1 \text{ m/s}^2$ , (c)  $1.5 \text{ m/s}^2$  and (d)  $2 \text{ m/s}^2$**



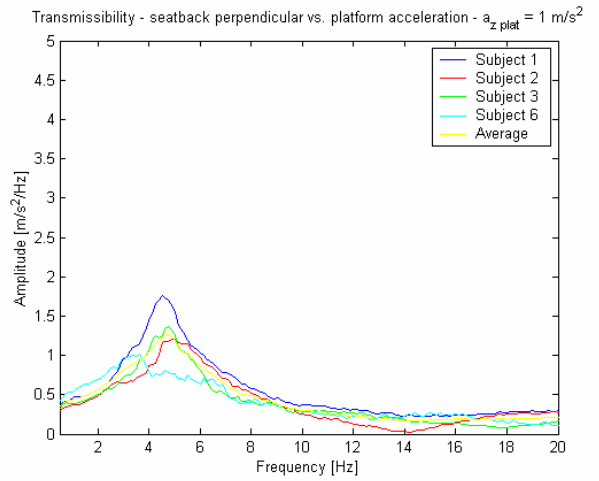
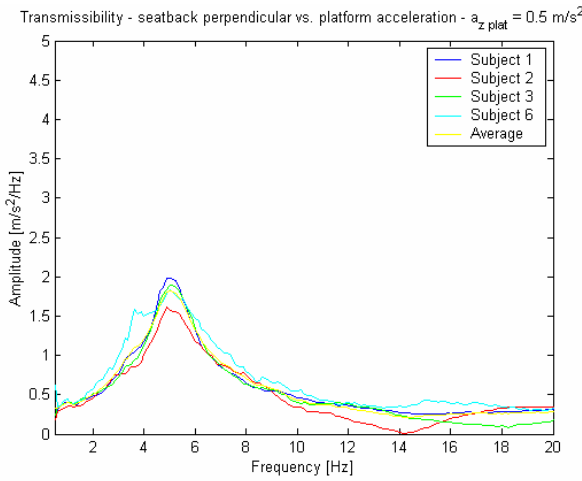
(a)



(b)

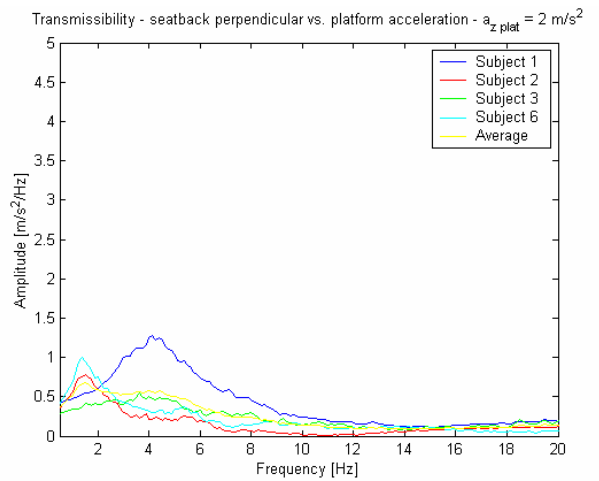
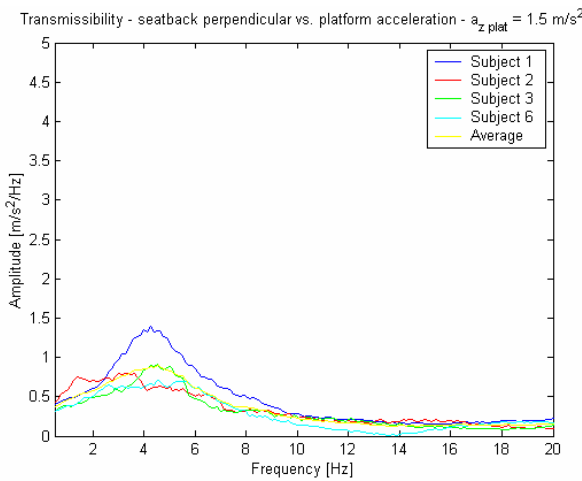


**Figure E.8 Seatback in-plane transmissibility of Seat C at (a) 0.5 m/s<sup>2</sup>, (b) 1 m/s<sup>2</sup>, (c) 1.5 m/s<sup>2</sup> and (d) 2 m/s<sup>2</sup>**



**(a)**

**(b)**



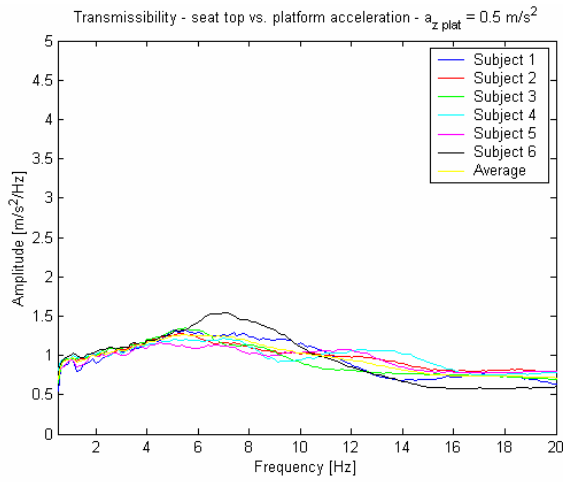
**(c)**

**(d)**

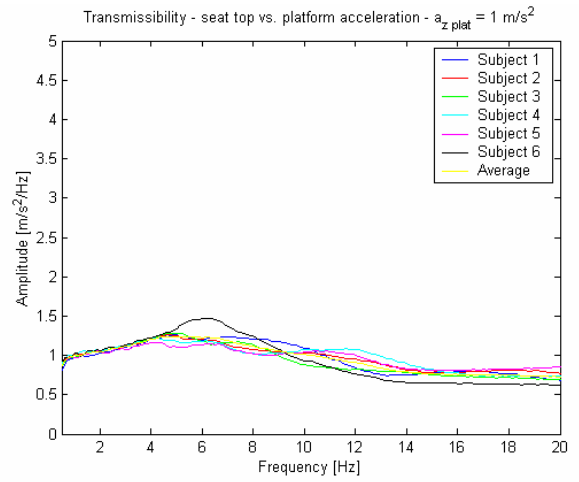
**Figure E.9 Seatback perpendicular transmissibility of Seat C at (a) 0.5 m/s<sup>2</sup>, (b) 1 m/s<sup>2</sup>, (c) 1.5 m/s<sup>2</sup> and (d) 2 m/s<sup>2</sup>**



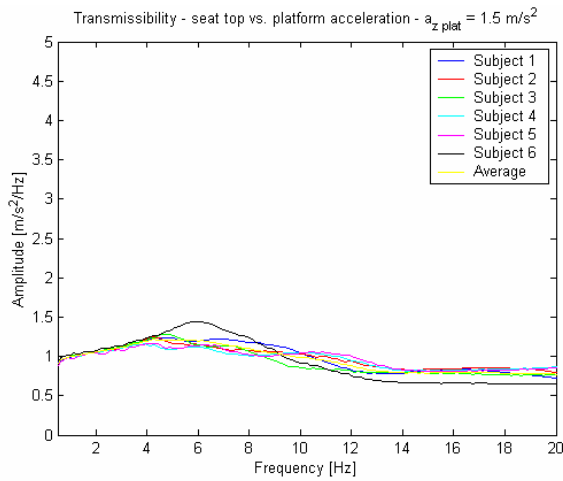
## E.4 Seat D



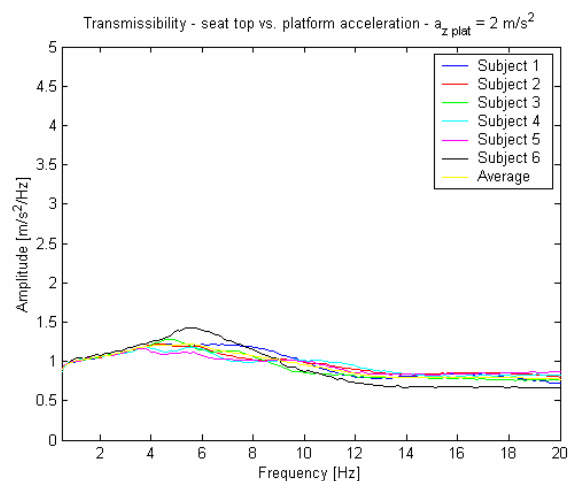
(a)



(b)

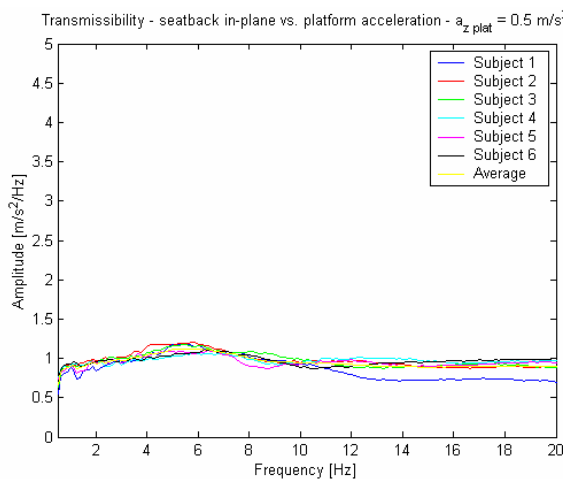


(c)

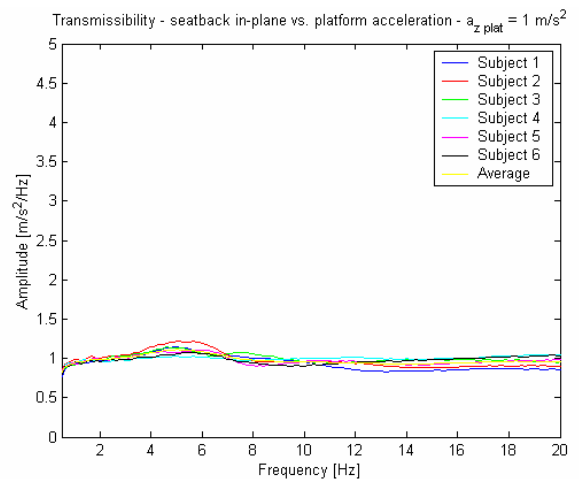


(d)

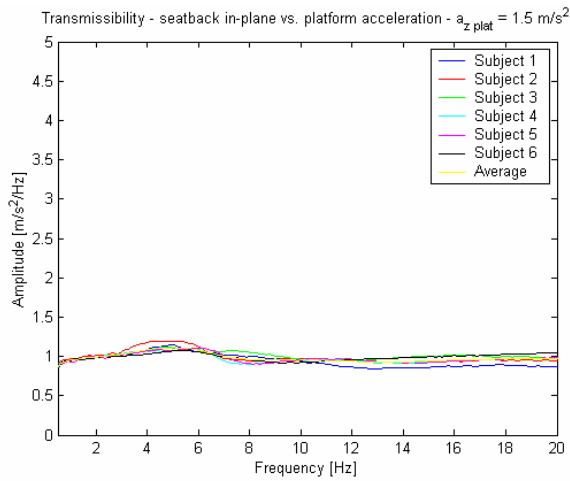
**Figure E.10 Seat top transmissibility of Seat D at (a)  $0.5 \text{ m/s}^2$ , (b)  $1 \text{ m/s}^2$ , (c)  $1.5 \text{ m/s}^2$  and (d)  $2 \text{ m/s}^2$**



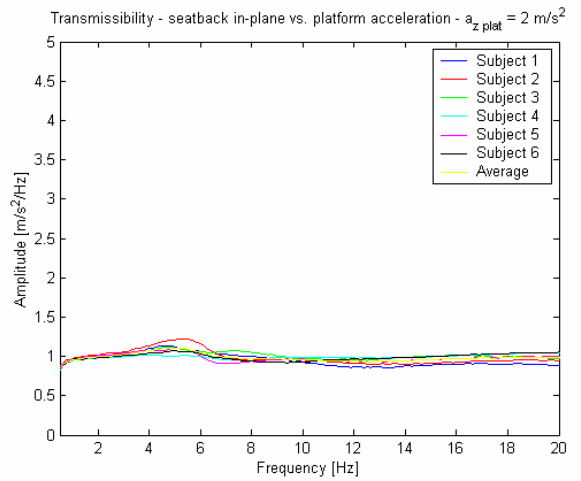
(a)



(b)

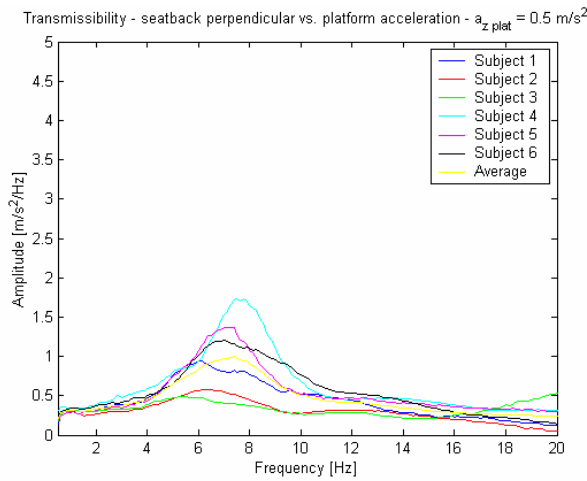


(c)

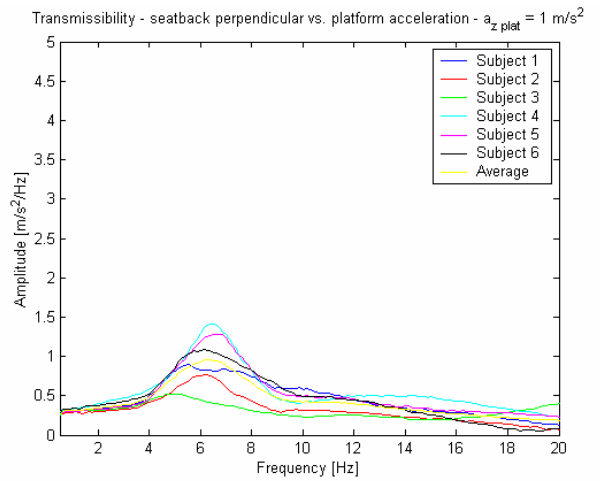


(d)

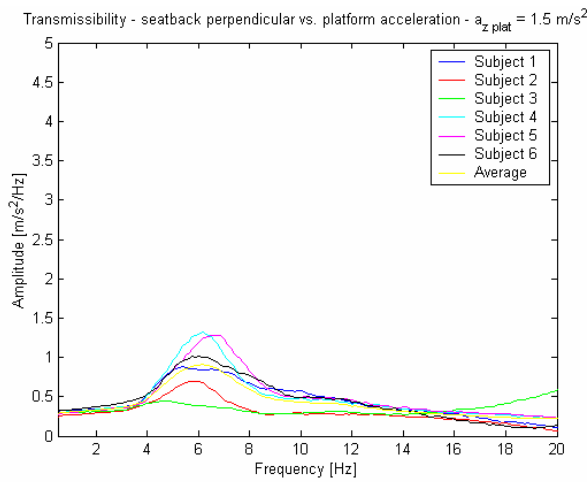
**Figure E.11 Seatback in-plane transmissibility of Seat D at (a) 0.5 m/s<sup>2</sup>, (b) 1 m/s<sup>2</sup>, (c) 1.5 m/s<sup>2</sup> and (d) 2 m/s<sup>2</sup>**



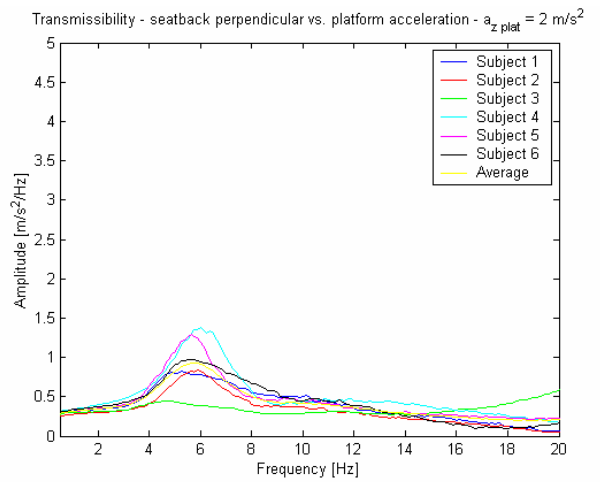
(a)



(b)



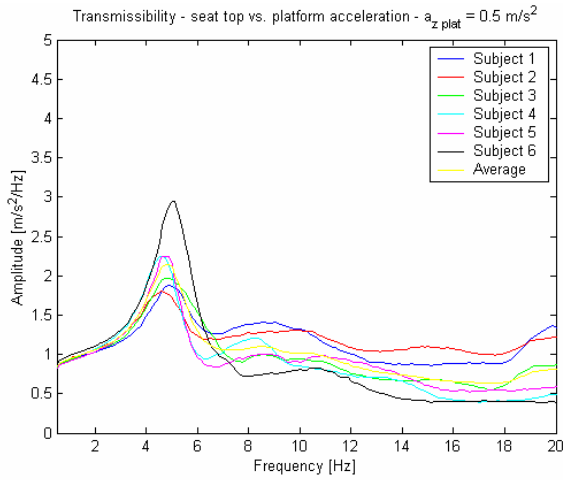
(c)



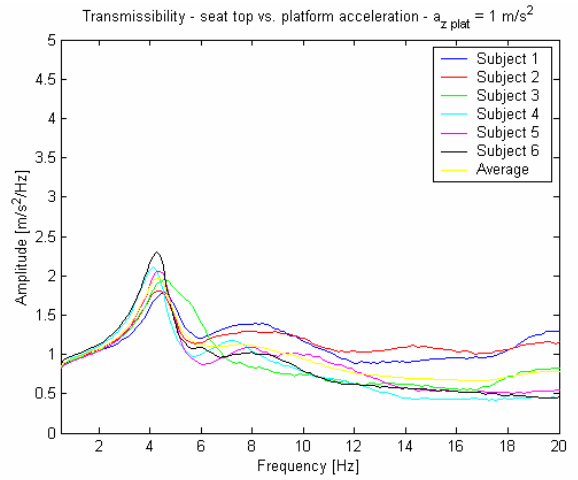
(d)

**Figure E.12 Seatback perpendicular transmissibility of Seat D at (a) 0.5 m/s<sup>2</sup>, (b) 1 m/s<sup>2</sup>, (c) 1.5 m/s<sup>2</sup> and (d) 2 m/s<sup>2</sup>**

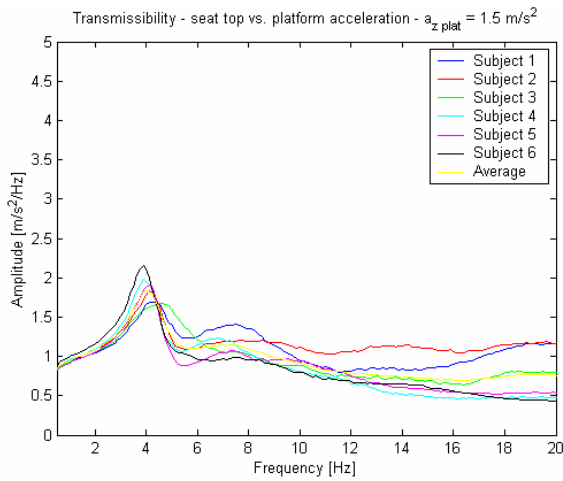
## E.5 Seat E



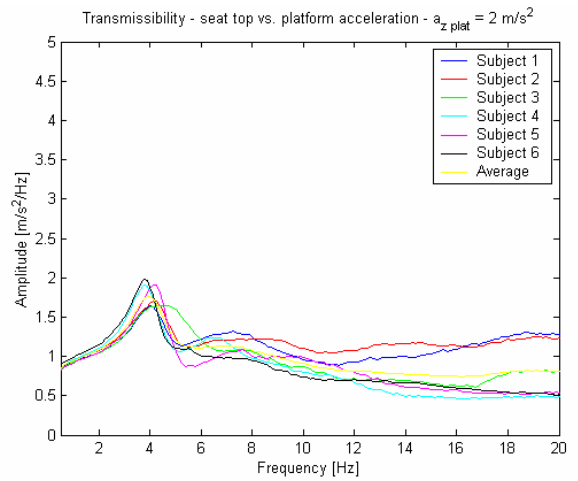
(a)



(b)

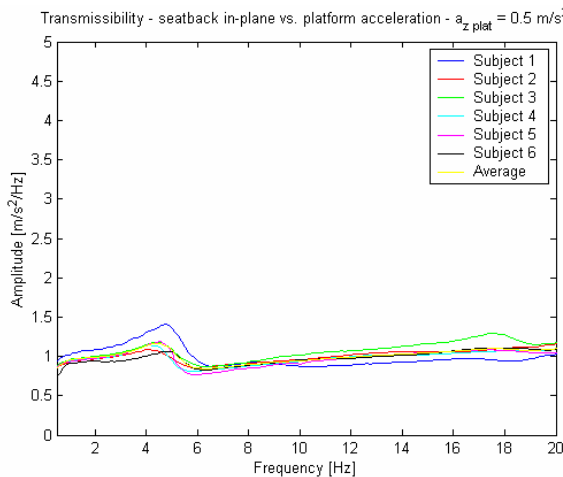


(c)

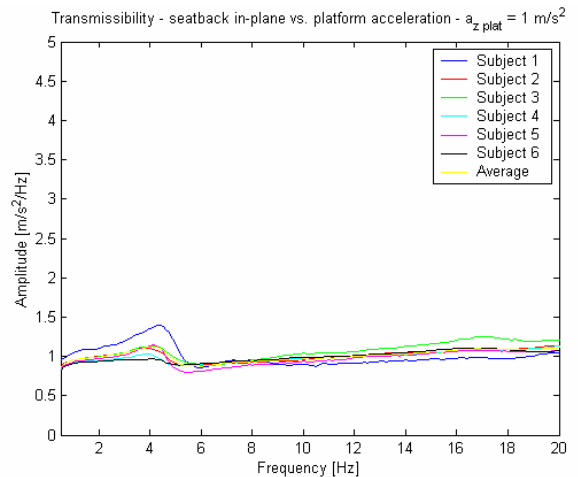


(d)

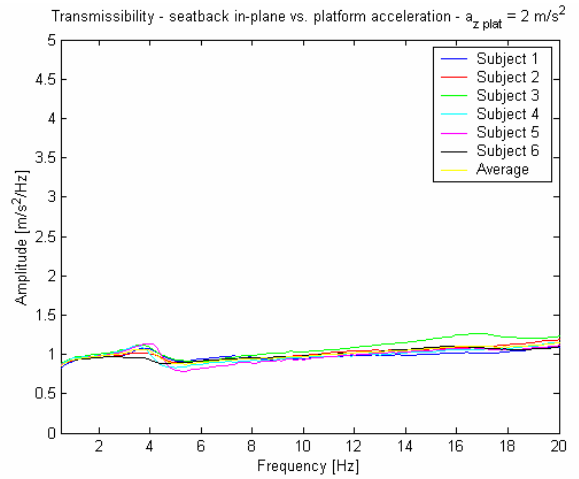
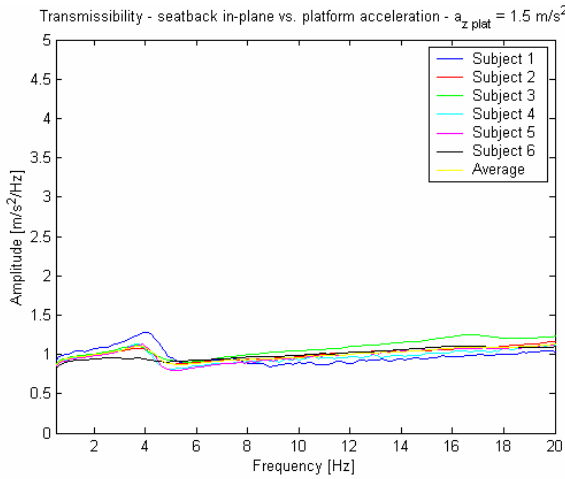
**Figure E.13 Seat top transmissibility of Seat E at (a) 0.5 m/s<sup>2</sup>, (b) 1 m/s<sup>2</sup>, (c) 1.5 m/s<sup>2</sup> and (d) 2 m/s<sup>2</sup>**



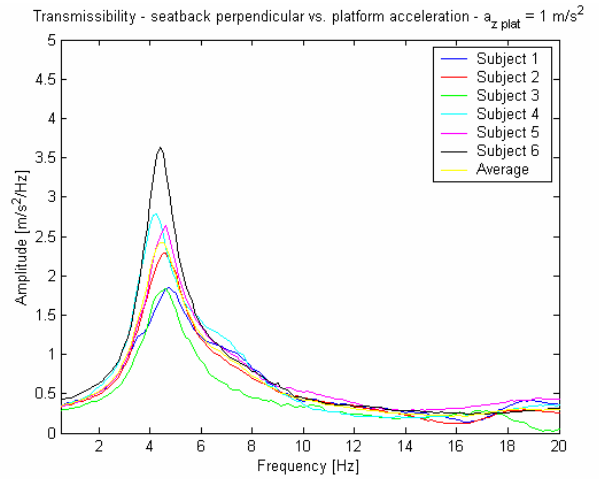
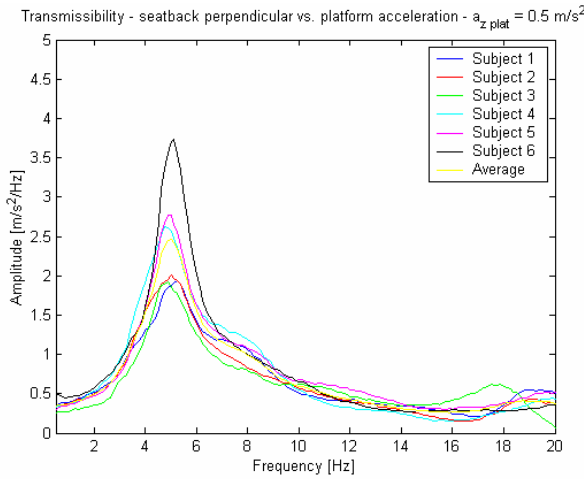
(a)



(b)

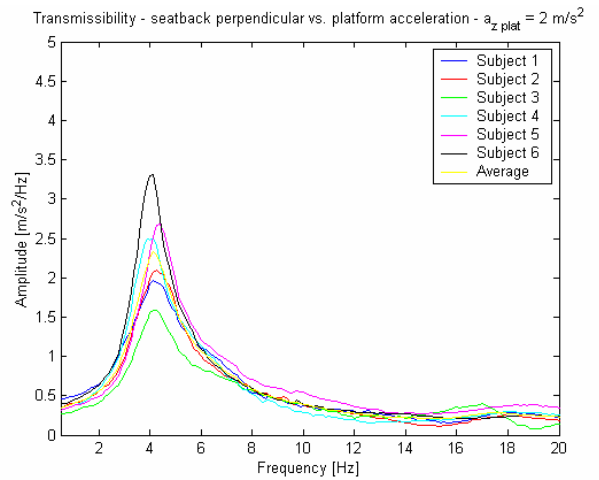
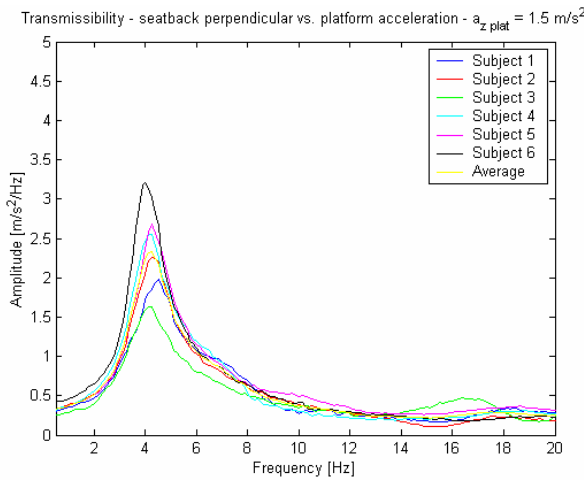


**Figure E.14 Seatback in-plane transmissibility of Seat E at (a)  $0.5 \text{ m/s}^2$ , (b)  $1 \text{ m/s}^2$ , (c)  $1.5 \text{ m/s}^2$  and (d)  $2 \text{ m/s}^2$**



**(a)**

**(b)**

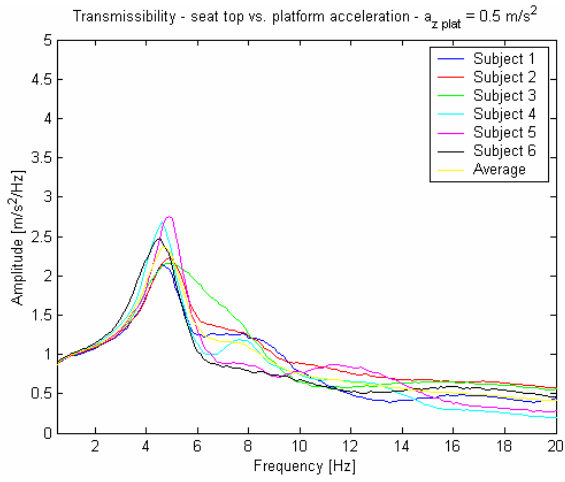


**(c)**

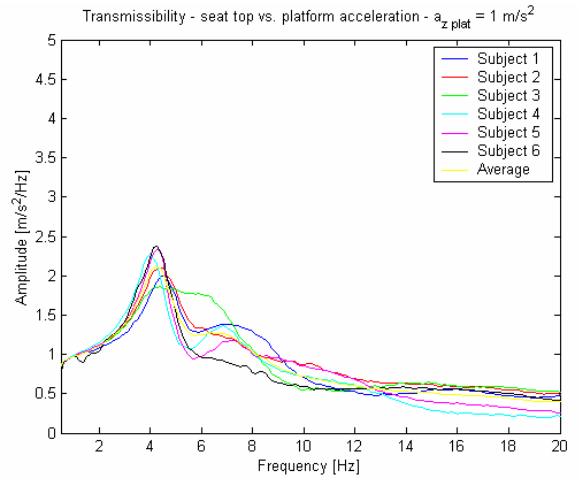
**(d)**

**Figure E.15 Seatback perpendicular transmissibility of Seat E at (a)  $0.5 \text{ m/s}^2$ , (b)  $1 \text{ m/s}^2$ , (c)  $1.5 \text{ m/s}^2$  and (d)  $2 \text{ m/s}^2$**

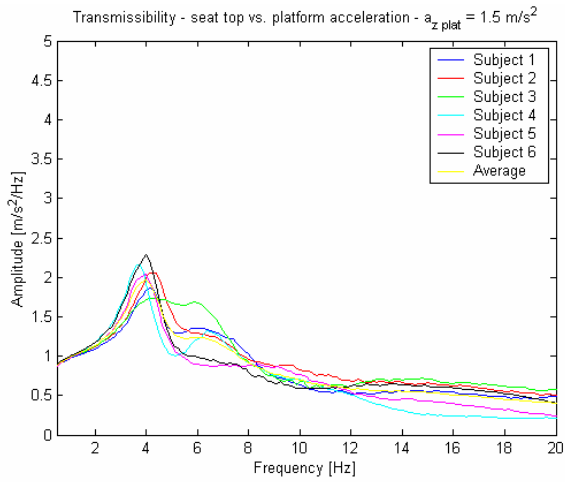
## E.6 Seat F



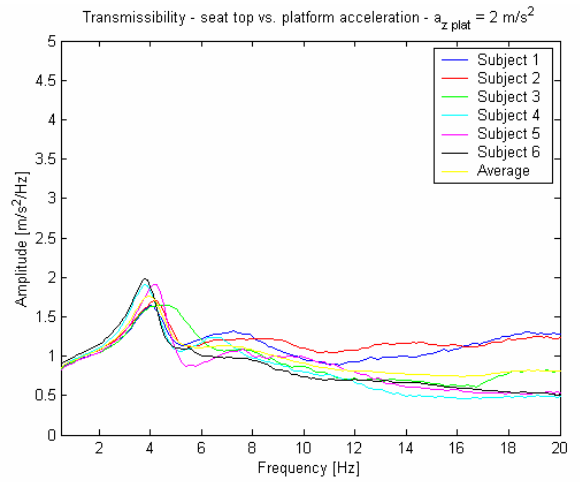
(a)



(b)

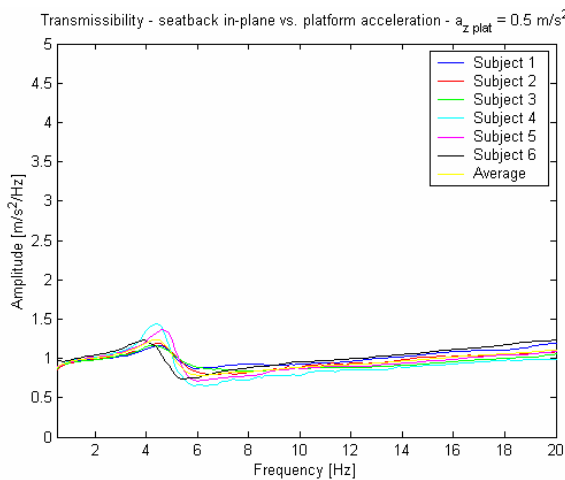


(c)

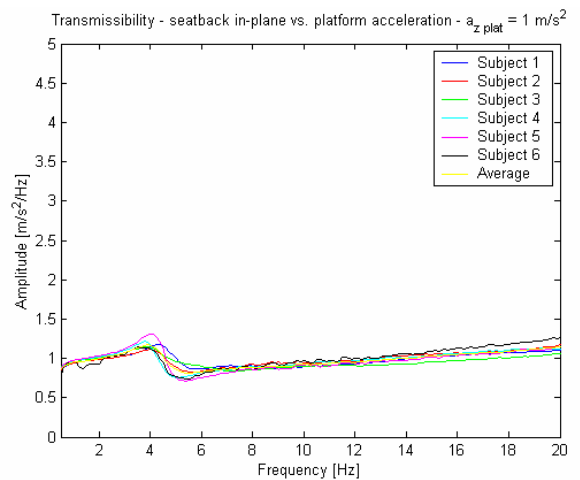


(d)

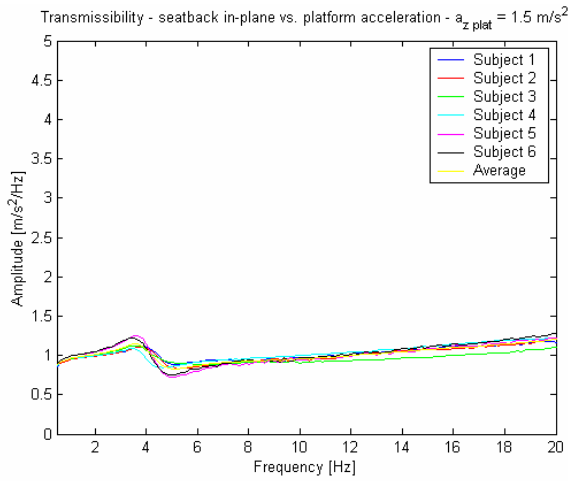
**Figure E.16 Seat top transmissibility of Seat F at (a) 0.5 m/s<sup>2</sup>, (b) 1 m/s<sup>2</sup>, (c) 1.5 m/s<sup>2</sup> and (d) 2 m/s<sup>2</sup>**



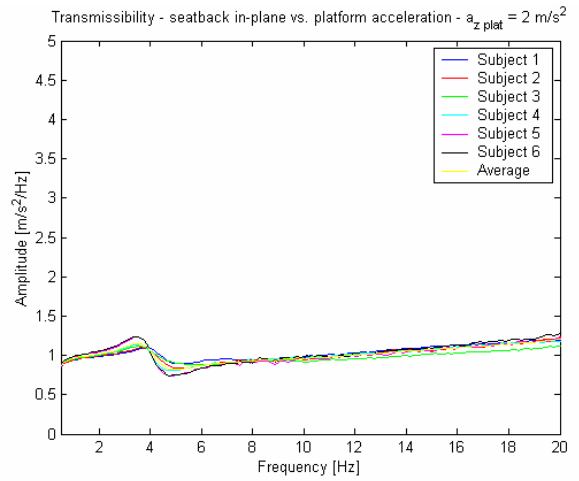
(a)



(b)

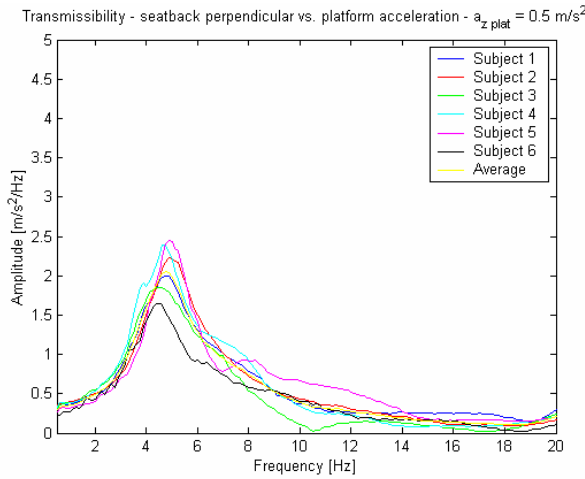


(c)

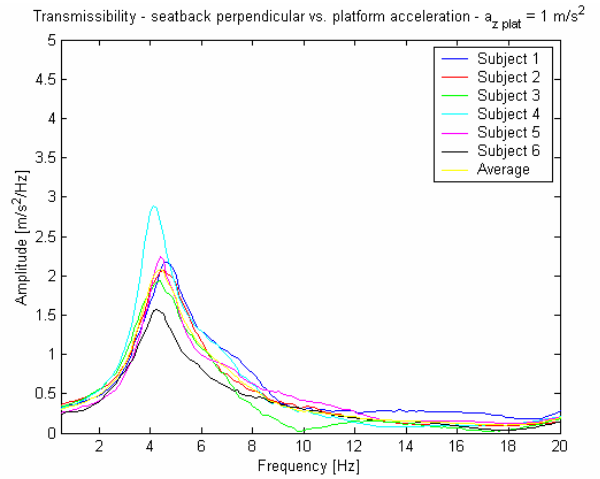


(d)

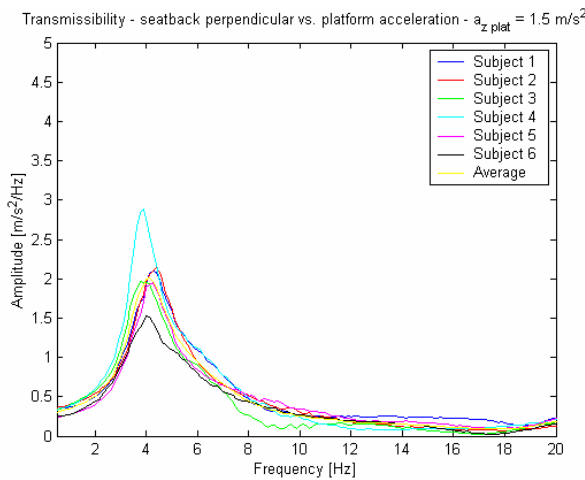
**Figure E.17 Seatback in-plane transmissibility of Seat F at (a)  $0.5 \text{ m/s}^2$ , (b)  $1 \text{ m/s}^2$ , (c)  $1.5 \text{ m/s}^2$  and (d)  $2 \text{ m/s}^2$**



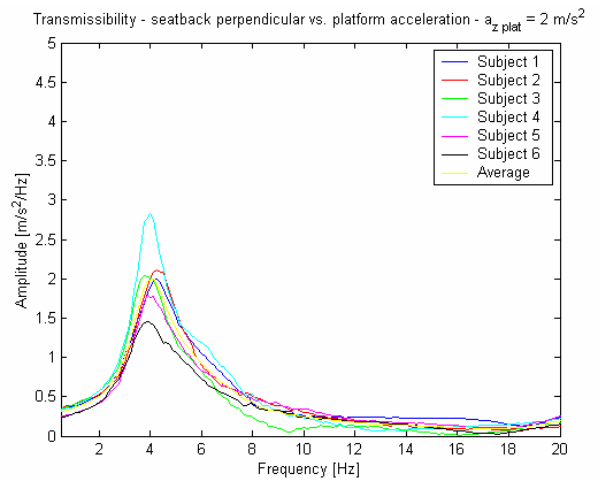
(a)



(b)



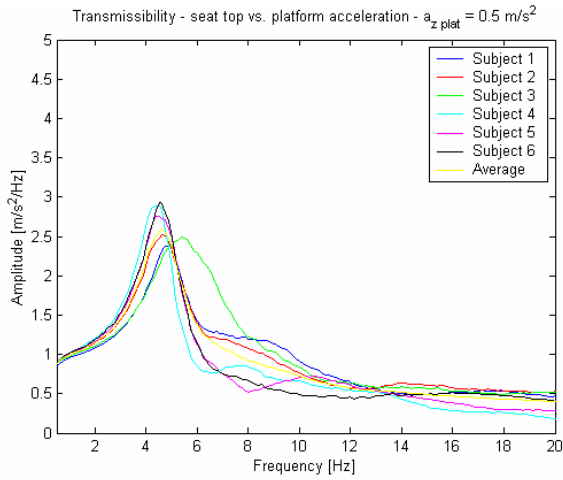
(c)



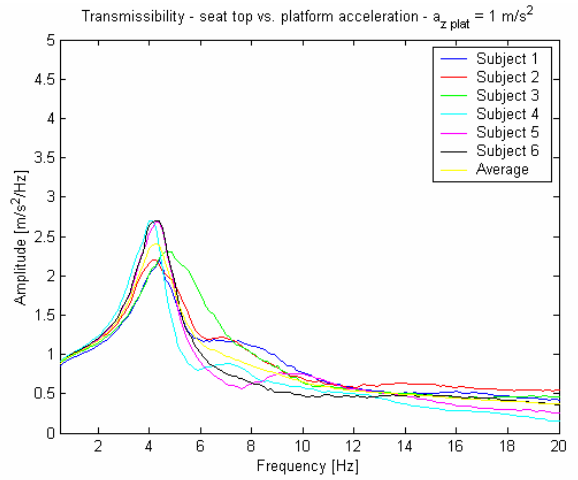
(d)

**Figure E.18 Seatback perpendicular transmissibility of Seat F at (a)  $0.5 \text{ m/s}^2$ , (b)  $1 \text{ m/s}^2$ , (c)  $1.5 \text{ m/s}^2$  and (d)  $2 \text{ m/s}^2$**

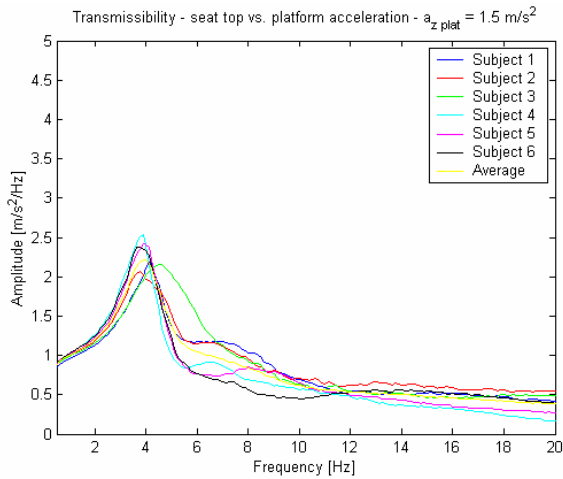
## E.7 Seat G



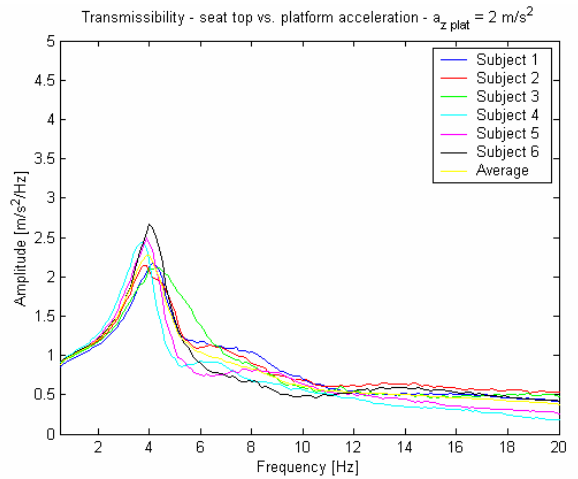
(a)



(b)

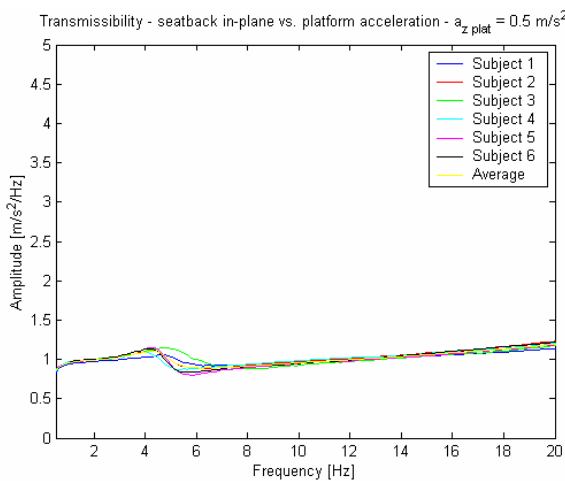


(c)

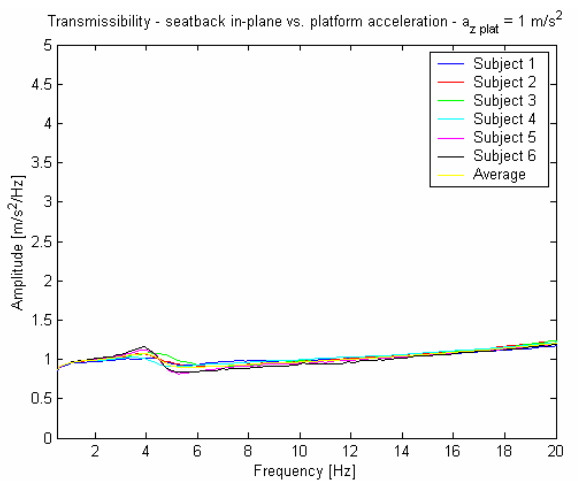


(d)

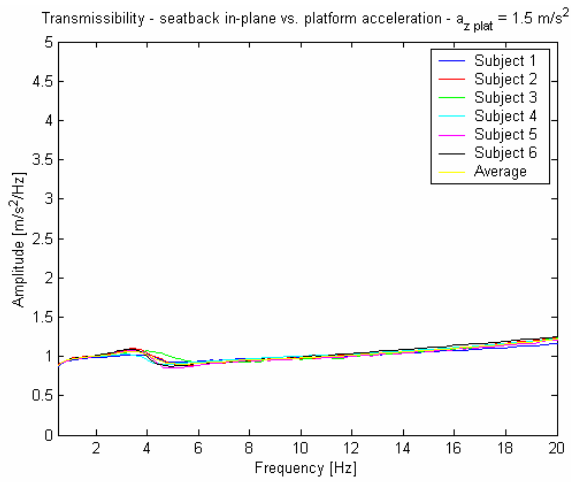
**Figure E.19 Seat top transmissibility of Seat G at (a) 0.5 m/s<sup>2</sup>, (b) 1 m/s<sup>2</sup>, (c) 1.5 m/s<sup>2</sup> and (d) 2 m/s<sup>2</sup>**



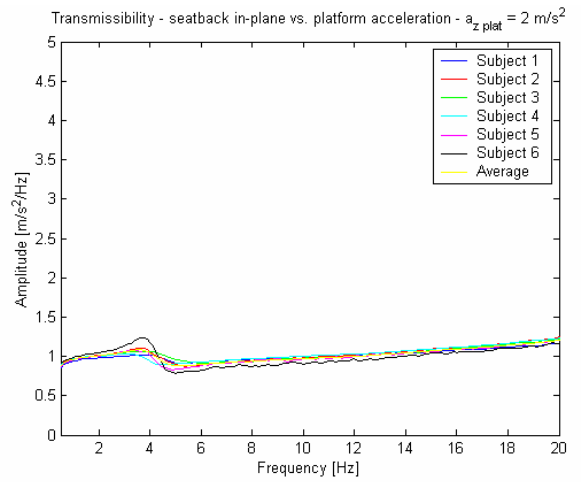
(a)



(b)

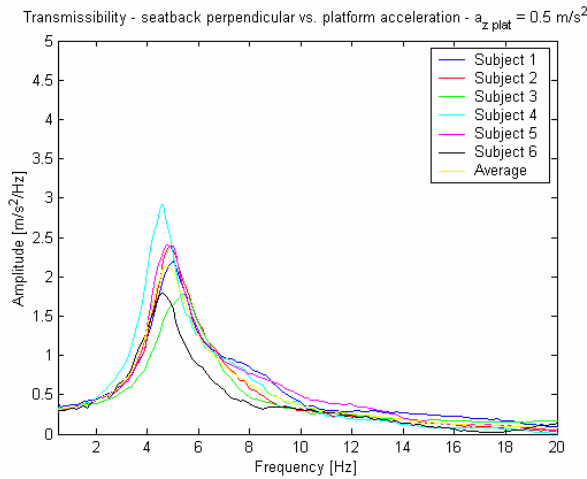


(c)

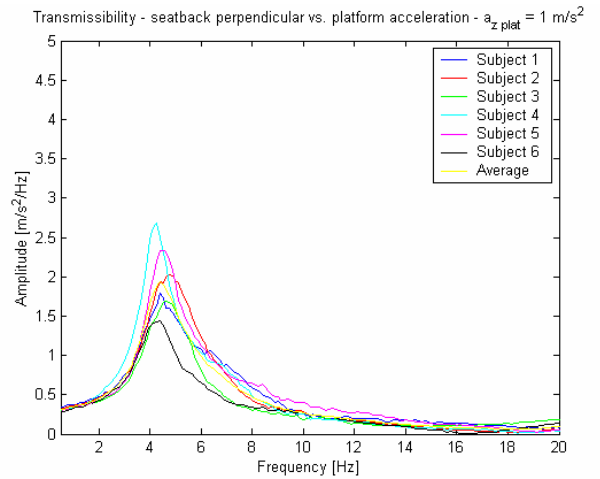


(d)

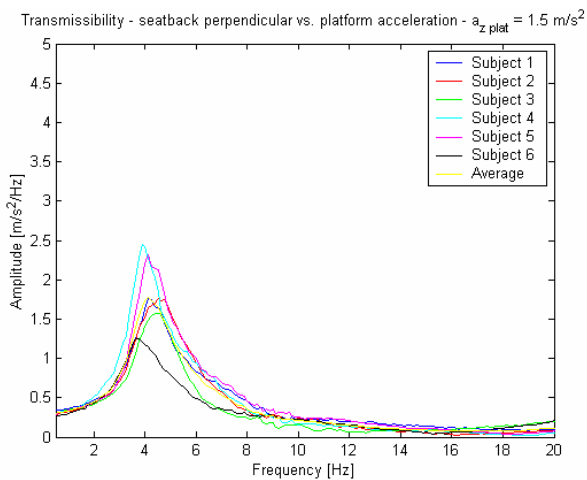
**Figure E.20 Seatback in-plane transmissibility of Seat G at (a) 0.5 m/s<sup>2</sup>, (b) 1 m/s<sup>2</sup>, (c) 1.5 m/s<sup>2</sup> and (d) 2 m/s<sup>2</sup>**



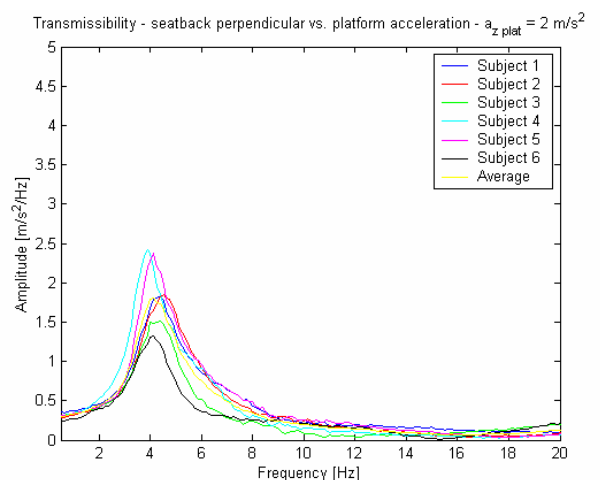
(a)



(b)



(c)



(d)

**Figure E.21 Seatback perpendicular transmissibility of Seat G at (a) 0.5 m/s<sup>2</sup>, (b) 1 m/s<sup>2</sup>, (c) 1.5 m/s<sup>2</sup> and (d) 2 m/s<sup>2</sup>**



“For the Lord your God will bless you in all your harvest and in all  
the work of your hands, and your joy will be complete”

*Deut 16:15*