

**MORPHOLOGICAL AND PHYSIOLOGICAL RESPONSES OF  
SPRING WHEAT (*Triticum aestivum* L.)  
TO SPATIAL ARRANGEMENTS**

John Peter Cleggenett Tolmay

Dissertation presented for the Degree Doctor of Philosophy (Agriculture) at  
Stellenbosch University



Promoter: Prof. G.A. Agenbag

Department of Agronomy  
Faculty of Agri Sciences

December 2008

## **Declaration**

By submitting this dissertation electronically, I declare that the entirety of the work contained therein is my own, original work, that I am the owner of the copyright thereof (unless to the extent explicitly otherwise stated) and that I have not previously in its entirety or in part submitted it for obtaining any qualification.

Date: 7 November 2008

Copyright © 2008 Stellenbosch University

All rights reserved

## Dedication

In my M.Sc. dissertation, I quoted Richard Horne as follows:

*Ye ridged Ploughmen! Bear in mind*

*Your labour is for future hours.*

*Advance! Spare not! Nor look behind!*

*Plough deep and straight with all your powers!*

*The plough*

Richard Henry Horne

1803-1884

I dedicate this work to all modern “Ploughmen” whom have embraced conservation tillage practices in order to make the business of food production more efficient, sustainable and profitable. Although this task may be less laborious today, it still requires the same dedication as two centuries ago. In this you have excelled.

## Abstract

The adoption of the no-till planting method brought about changes to the way the wheat crop is established in the Mediterranean climate of the Western Cape. Row widths have to increase from the normal narrow rows (170-180 mm) to at least 250 mm to allow for sufficient stubble handling. Furthermore, planters are designed to place seed accurately in the soil at uniform depth, which may increase seedling survival rates. The main objective of this study was to determine the influence of the use of wide row widths on yield, the components of yield and grain quality parameters and to revisit planting density recommendations to be used with the no-till planting method.

On-farm, producer managed trials which included cultivars, row widths and planting density treatments were planted at Riversdale, Swellendam and Caledon in the Southern Cape region and at Moorreesburg and Hopefield in the Swartland during the 2004 to 2006 production seasons. All trials were factorial RCB designs with split-split plot arrangements. Grain yield, grain protein, hectolitre mass (HLM) and the yield components, seedlings  $m^{-2}$ , seedling survival (%), number of heads  $m^{-2}$ , number of heads  $plant^{-1}$ , number of kernels  $head^{-1}$  and thousand kernel mass (TKM) were determined at all sites in 2005 and 2006.

Seedling survival rates of 80% were easily achieved in all trials with the exception of Caledon and Swellendam in 2005. The no-till planting method may be efficient to improve on survival rates of 50-70% found with the conventional planting methods. The yield component response that raised the most concern was the clear trend of the reduction in the number of heads  $m^{-2}$  as row widths increased, which was significant in eight out of the nine experiments. The number of heads  $plant^{-1}$  decreased significantly as planting density increased in all experiments. Cultivars differed in the grain quality parameters grain protein (%) and HLM but were influenced minimally by the other treatments. Reductions in grain yield occurred in three out of eight trials in the Southern Cape and in three out of six trials in the Swartland, with reductions of between 6.8% and 33% in some seasons. The risk of yield loss due to wide row widths could not be excluded by this study and therefore the row widths used by producers should remain as narrow as practically possible. Grain yield response to increasing planting density differed between the two regions. No significant yield benefits were found in any of these trials if planting densities were increased above 175 target plants  $m^{-2}$ . Planting densities may be reduced to between 70 and 87.5 kg seed  $ha^{-1}$  to achieve this target if the crop is planted in time and seedling survival rates of at least 80% can be achieved.

## Opsomming

Die oorskakeling na bewaringsboerderystelsels in die Wes-Kaap het belangrike veranderinge in die koring produksiestelsel meegebring. Eerstens moes rywydte van die normale 170-180 mm na 250 mm of meer verbreed word om stoppelvloeit te verbeter en tweedens kan verhoogde saailingoorlewingspersentasies met moderne planters verwag word. Die hoofdoelwit van hierdie studie was om die invloed van wye rye op graanopbrengs, opbrengskomponente en graankwaliteit vas te stel. Verder moes plantdigtheidsaanbevelings vir die gebruik in bewaringsbewerking hersien word.

Veldproewe is op plase van produsente in Riversdal, Swellendam en Caledon in die Suid-Kaap en by Moorreesburg en Hopefield in die Swartland uitgevoer. Die proewe is in produsente se graanlande geplant en bestuurspraktyke soortgelyk aan die van die produsent, is toegepas. Proefontwerpe was deurgaans faktoriaal in dubbel verdeelde persele ("split-split plots") en is in volledig gerandomiseerde blokke aangeplant. Graanopbrengs, graanproteïen (%) en hektolitermassa (HLM), sowel as die opbrengskomponente, saailinge  $m^{-2}$ , saailingoorlewing (%), aargetal  $m^{-2}$ , aargetal plant $^{-1}$ , korrelgetal aar $^{-1}$  en duisendkorrelmassa (DKM) is in die studie bepaal.

Saailingoorlewingspersentasies van meer as 80% was redelik maklik in al die proewe, met die uitsondering van Swellendam en Caledon in 2005, verkry. Dus kan die planters wat met verminderde bewerking gebruik word as redelik effektief beskou word om op die lae sailingoorlewing (50-70%) van vorige plantmetodes te verbeter. Die vermindering in aargetal  $m^{-2}$  as gevolg van vermeerdering in rywydte, wat by agt uit nege eksperimente waargeneem is, kan negatiewe gevolge vir opbrengs hê. Die aargetal plant $^{-1}$  het in alle eksperimente afgeneem wanneer die plantpopulasie toegeneem het. Graanproteïen (%) en HLM van verskillende cultivars het betekenisvol verskil, maar die ander behandelings in die studie het weinig invloed op graankwaliteit gehad. Betekenisvolle verlagings in graanopbrengs as gevolg van wyer rywydtes het in drie uit agt proewe in die Suid-Kaap en drie uit ses proewe in die Swartland voorgekom. Die risiko van opbrengsverlaging as gevolg van wyer rywydtes kon nie met hierdie studie uitgesluit word nie en rywydtes so smal as prakies moontlik, word aanbeveel. Die respons van opbrengs op plantdigtheid vir die twee produksiestreke het verskil, maar geen verbetering in opbrengs is in die twee streke verkry deur van teikendighede van hoër as 175 plante  $m^{-2}$  gebruik te maak nie. Plantdigthede kan dus effens afwaarts aangepas word wanneer van hierdie plantmedode gebruik gemaak word en daar word aanbeveel dat tussen 70 en 87.5 kg saad  $ha^{-1}$  (afhangend van DKM) nodig sal wees om die gewenste teikenpopulasie te bereik. Afwaartse aanpassings behoort slegs gemaak te word as die planttyd binne die aanbevole tydperk van die cultivar val en saailingoorlewingspersentasies van 80% of hoër, met die planter haalbaar is.

## Acknowledgements

I acknowledge and thank the following persons and institutions for contributing towards this study or creating the enabling environment needed for this to have become a reality.

Prof G. A. Agenbag, Department of Agronomy at the University of Stellenbosch for promoting this study. Thank you for your excellent leadership, mentoring and patience.

Dr Freddie Ellis at the Department of Soil Science, University of Stellenbosch, for help and advice regarding soil pedology.

ARC-Small Grain Institute, for affording me the opportunity to continue with my studies and all resources (equipment, manpower and time) made available to me. Mr Willem Kilian, my Programme Manager, for initialising the project, mentorship and scientific advice. The Winter Cereal Trust for providing sufficient funding to support such a large-scale research project.

The many people who have made technical contributions towards the project, especially Messrs Pontsho Mokoena (the team leader) and Alfred Mahlangu (technical assistant) who have been part of this project since its inception 2002. Without your assistance, execution of this project would simply not have been possible. Thank you for supporting me all this time and all the extra hours and effort you have put in.

Dr Mark Hardy (Western Cape Department of Agriculture) for helping to integrate this project into the larger scientific framework to promote the adoption of conservation agriculture. Thank you for excellent collaboration and all the scientific inputs made.

To my wife Vicki and children Sam and Nina for enduring with a travelling and studying husband and father for almost half a decade. Without your support, this would not have been possible. Thank you Vicki for excellent proof reading and helping me make so many important decisions with regards to this study. To my parents, who installed a love of learning into our family and followed my progress with so much interest.

A special thank you goes to all the producers and co-managers whose land was used for the execution of these trials. Trials in your fields can be a nuisance and always demand extra inputs. All of you welcomed these activities because you acknowledge the value of research. So, thank you to:

Fanie Joubert	Uitkyk	Riversdale
Joos Badenhorst	Middeldrif	Swellendam
Heindrich Schönfeldt	Heuningneskloof	Caledon
Cobus Bester	Klein Swartfontein	Moorreesburg
Jan (Kwak) du Toit	Karbonaaitjieskraal	Hopefield
Gideon Melck	Waterboerskraal	Hopefield

Most importantly, praise to our creator, God Almighty, for the talents given and the strength to complete this study.

*I can do anything through Christ who gives me strength. Philippians 4:13*

## List of Abbreviations

Abbreviation	Meaning
C	Carbon
Ca : Mg	Ca to Mg ratio
CV	Cultivar
Cv (%)	Coefficient of variance
CV x PD	Cultivar by planting density interaction
CV x RW	Cultivar by row width interaction
CV x RW x PD	Cultivar by row width by planting density interaction
ha <sup>-1</sup>	per hectare
head <sup>-1</sup>	per head
hl <sup>-1</sup>	per hectolitre
HLM	Hectolitre mass in kilogram per hectolitre (kg hl <sup>-1</sup> )
HRSW	Hard red spring wheat
HRWW	Hard red winter wheat
LT Tmax	Long-term maximum temperature
LT Tmin	Long-term minimum temperature
m <sup>-2</sup>	per square meter
MAP	Mono ammonium phosphate
PD	Planting density
pH <sub>(KCL)</sub>	pH with KCl extraction
plant <sup>-1</sup>	per plant
PR>F	Significance levels
RCB	Randomised complete block (design)
RW	Row width
RW x PD	Row width by planting density interaction
spikelet <sup>-1</sup>	per spikelet
SRWW	Soft red winter wheat
target (no.) of plants m <sup>-2</sup>	Target number of plants per square meter
TKM	Thousand kernel mass in gram (g) per thousand kernels
Tmax	Maximum temperature
Tmin	Minimum temperature

Abbreviations of common SI units, element names and citation symbols are not listed.

Heads - Are also referred to as spikes or ears in some literature

Tillers - Are also referred as culms in some literature



# Table of Contents

---

<b>CHAPTER 1</b>		<b>Page</b>
<b>Introduction to this study</b>		<b>1</b>
Objectives of this study		<b>6</b>
Outside the scope of this study		<b>7</b>
Outlay of this dissertation		<b>7</b>
 <b>CHAPTER 2</b>		
<b>Literature review</b>		<b>8</b>
Conservation tillage as a practice		<b>8</b>
Crop response to spatial arrangement		<b>15</b>
Seedling survival		<b>16</b>
Altering spatial arrangement by increasing row width		<b>16</b>
The relationship between planting density and grain yield		<b>17</b>
The interaction between cultivars, row width and planting density		<b>20</b>
 <b>CHAPTER 3</b>		
<b>Description of approach, equipment, trial sites, climatic conditions, cultivars and experimental procedure</b>		<b>21</b>
Introduction		<b>21</b>
On-farm field trial approach		<b>21</b>
Planting equipment used		<b>22</b>
Description of the trial sites		<b>25</b>
<i>Riversdale</i>		<b>25</b>
<i>Swellendam</i>		<b>26</b>
<i>Caledon</i>		<b>27</b>
<i>Moorreesburg</i>		<b>28</b>
<i>Hopefield</i>		<b>28</b>
Seasonal rainfall at the trial sites		<b>30</b>
<i>Southern Cape sites</i>		<b>30</b>
<i>Swartland sites</i>		<b>35</b>
Temperatures during the study period		<b>38</b>

Description of cultivars	40
Description of experimental procedure	41
Soil analysis	47
Statistical analysis and presentation of data	47

## CHAPTER 4

<b>The influence of row width and planting density on wheat in conservation tillage systems in the Western Cape: Part 1: Plant establishment and seedling survival</b>	<b>48</b>
Introduction	48
Experimental procedure	48
Results	49
<i>Seedlings m<sup>2</sup></i>	51
<i>Seedling survival (%)</i>	55
Discussion	57
Conclusion	59

## CHAPTER 5

<b>The influence of row width and planting density on wheat in conservation tillage systems in the Western Cape: Part 2: Yield components in the Southern Cape</b>	<b>60</b>
Introduction	60
Experimental procedure	60
Results	61
<i>The number of heads m<sup>2</sup></i>	61
<i>The number of heads plant<sup>1</sup></i>	66
<i>The number of kernels head<sup>1</sup></i>	67
<i>Thousand Kernel Mass</i>	71
Discussion	73
<i>Cultivar response</i>	73
<i>Response to row width</i>	74
<i>Response to planting density</i>	75
Conclusion	77

## CHAPTER 6

<b>The influence of row width and planting density on wheat in conservation tillage systems in the Western Cape: Part 3: Grain yield, grain protein and hectolitre mass in the Southern Cape region</b>	<b>79</b>
Introduction	79
Experimental procedure	79
Results	80
<i>Grain yield</i>	82
<i>Grain protein (%)</i>	86
<i>Hectolitre mass</i>	89
Discussion	90
<i>Cultivar response</i>	90
<i>Response to row width</i>	91
<i>Response to planting density</i>	93
Conclusion	94

## CHAPTER 7

<b>The influence of row width and planting density on wheat in conservation tillage systems in the Western Cape: Part 4: Yield components in the Swartland</b>	<b>96</b>
Introduction	96
Experimental procedure	96
Results	97
<i>The number of heads m<sup>-2</sup></i>	97
<i>The number of heads plant<sup>-1</sup></i>	101
<i>The number of kernels head<sup>-1</sup></i>	103
<i>Thousand Kernel Mass</i>	105
Discussion	106
<i>Cultivar response</i>	106
<i>Response to row width</i>	107
<i>Response to planting density</i>	108
Conclusion	110

## CHAPTER 8

<b>The influence of row width and planting density on wheat in conservation tillage systems in the Western Cape: Part 5: Grain yield, grain protein and hectolitre mass in the Swartland</b>	<b>111</b>
Introduction	111
Experimental procedure	111
Results	112
<i>Grain yield</i>	112
<i>Grain Protein (%)</i>	117
<i>Hectolitre mass</i>	119
Discussion	121
<i>Cultivar response</i>	121
<i>Response to row width</i>	123
<i>Response to planting density</i>	125
Conclusion	127

## CHAPTER 9

<b>Some relationships between the components of yield and final recommendations</b>	<b>128</b>
Introduction	128
Comparison of yield components in the Western Cape: Historical versus new data	129
The relationship between plant population and grain yield	131
The relationship between plant population and heads plant <sup>-1</sup>	132
The relationship between head population and grain yield	135
Planting density recommendations	137
Final recommendations from this study	138
<b>Summary</b>	<b>139</b>
<b>References</b>	<b>143</b>

## List of tables

		<b>Page</b>
<b>Table 2.1</b>	Advantages, disadvantages and potential problems experienced with the use of conservation tillage	<b>10</b>
<b>Table 3.1</b>	Localities, farm name, latitude, longitude and previous crop for each locality used in the Western Cape for the seasons 2004-2006	<b>26</b>
<b>Table 3.2</b>	General description of soils at the different localities	<b>27</b>
<b>Table 3.3</b>	Soil chemical properties in the topsoil (0-15mm) of the A-horizon at the different localities taken in the last season (2006)	<b>28</b>
<b>Table 3.4</b>	Rainfall for 2004-2006 in 10 or 11 day periods at the trial sites in the Southern Cape	<b>31</b>
<b>Table 3.5</b>	Rainfall for 2004-2006 in 10 day periods in the Swartland	<b>36</b>
<b>Table 3.6</b>	Summary of characteristics of cultivars included in this study	<b>41</b>
<b>Table 3.7</b>	Planting dates, harvesting dates and the growing period (number of days between planting and harvesting) at each locality in the Western Cape 2004-2006	<b>42</b>
<b>Table 3.8</b>	Thousand Kernel Mass (g) for the cultivars used	<b>43</b>
<b>Table 3.9</b>	Cultivars, target (no.) of plants m <sup>-2</sup> and planting densities (kg seed ha <sup>-1</sup> ) used as treatments at the different localities 2004-2006	<b>44</b>
<b>Table 4.1</b>	Summary of localities, years, treatments and data collected	<b>49</b>
<b>Table 4.2</b>	Pr>F values and coefficients of variance of the main effects and interactions for seedlings m <sup>-2</sup> and seedling survival (%) 2005-2006	<b>50</b>
<b>Table 4.3</b>	The cultivar planting density interaction for seedling number m <sup>-2</sup> and treatment means for seedling survival (%) at Hopefield 2006	<b>52</b>
<b>Table 4.4</b>	Treatment means for number of seedlings m <sup>-2</sup> at Swellendam 2005	<b>53</b>
<b>Table 4.5</b>	Treatment means (main effects) of row widths and planting density at Riversdale and Swellendam in 2006	<b>53</b>

<b>Table 4.6</b>	Interactions between row widths and planting density for seedlings m <sup>-2</sup> and seedling survival (%) at Caledon and Moorreesburg in 2006	<b>54</b>
<b>Table 4.7</b>	The row width x planting density interaction for seedling survival (%) at Swellendam 2005	<b>56</b>
<b>Table 5.1</b>	Summary of localities, seasons, treatments and data collected at the Southern Cape localities (Part 2)	<b>61</b>
<b>Table 5.2</b>	Pr >F values and coefficients of variance of the main effects and interactions for heads m <sup>-2</sup> , heads plant <sup>-1</sup> , kernels head <sup>-1</sup> and kernel weight in the Southern Cape trials during 2005 and 2006	<b>62</b>
<b>Table 5.3</b>	The influence of target planting density on heads m <sup>-2</sup> and heads plant <sup>-1</sup> at Riversdale, Swellendam and Caledon for the 2005 and 2006 seasons	<b>65</b>
<b>Table 5.4</b>	The interactions of cultivars x planting density and cultivar x row width for heads plant <sup>-1</sup> at Swellendam 2005	<b>66</b>
<b>Table 5.5</b>	The treatment means of number of kernels head <sup>-1</sup> for planting densities at Caledon 2005	<b>70</b>
<b>Table 5.6</b>	Thousand kernel mass (g) for cultivars at the Southern Cape localities in 2005 and 2006	<b>71</b>
<b>Table 5.7</b>	Thousand kernel mass (g) for row width and planting density at Riversdale and Caledon 2006	<b>72</b>
<b>Table 6.1</b>	Summary of localities, seasons, treatments and data collected at the Southern Cape localities	<b>80</b>
<b>Table 6.2</b>	Pr >F values, and coefficients of variance of the main effects and interactions in the Southern Cape trials during the period 2004-2005	<b>81</b>
<b>Table 6.3</b>	Cultivar and planting density interaction for grain protein and hectolitre mass at Riversdale 2004 and 2006	<b>87</b>
<b>Table 6.4</b>	Row width x Cultivar interactions for grain protein and hectolitre mass at Swellendam 2006	<b>88</b>
<b>Table 6.5</b>	Treatment means for (cultivars and row widths) for grain protein (%) at Caledon in 2006	<b>88</b>
<b>Table 6.6</b>	Treatment means (cultivars and planting densities) for hectolitre mass at Caledon in 2004	<b>89</b>

<b>Table 6.7</b>	Treatment means (cultivars and planting densities) for hectolitre mass at Swellendam in 2005	<b>90</b>
<b>Table 7.1</b>	Summary of localities, seasons, treatments and data collected at the Swartland localities	<b>97</b>
<b>Table 7.2</b>	Pr >F values and coefficients of variance of the main effects and interactions for heads m <sup>-2</sup> , heads plant <sup>-1</sup> , kernels head <sup>-1</sup> and kernel weight in the Swartland trials during 2005 and 2006	<b>98</b>
<b>Table 7.3</b>	The influence of target planting density on heads m <sup>-2</sup> and heads plant <sup>-1</sup> at Moorreesburg and Hopefield for the 2005 and 2006 seasons	<b>101</b>
<b>Table 8.1</b>	Summary of localities, seasons, treatments and data collected at the Swartland localities	<b>112</b>
<b>Table 8.2</b>	Pr >F values, and coefficients of variance of the main effects and interactions in the Swartland Cape trials during the period 2004-2005	<b>113</b>
<b>Table 8.3</b>	The planting density (PD) x cultivar (CV) interaction for grain yield (ton ha <sup>-1</sup> ) at Moorreesburg 2004	<b>114</b>
<b>Table 8.4</b>	The significant cultivar (CV) x row width (RW) x planting density (PD) interaction found for grain yield (ton ha <sup>-1</sup> ) at Hopefield in 2004	<b>115</b>
<b>Table 8.5</b>	Treatment means for planting densities (PD) and cultivars (CV) for grain yield (ton ha <sup>-1</sup> ) at Moorreesburg and Hopefield during 2005	<b>115</b>
<b>Table 8.6</b>	Treatment means for row widths (RW) and planting density (PD) for grain yield (ton ha <sup>-1</sup> ) at Hopefield 2006	<b>116</b>
<b>Table 8.7</b>	Treatment of row widths and planting densities for grain protein (%) at Hopefield in 2005 and 2006	<b>118</b>
<b>Table 8.8</b>	The cultivar (CV) x row width (RW) interaction and treatment means for planting densities for grain protein (%) at Moorreesburg 2006	<b>119</b>
<b>Table 8.9</b>	Planting density (PD) x row width (RW) x cultivar (CV) interaction for hectolitre mass (kg hl <sup>-1</sup> ) at Moorreesburg in 2005	<b>120</b>
<b>Table 8.10</b>	Planting density (PD) x row width (RW) x cultivar (CV) interaction for hectolitre mass (kg hl <sup>-1</sup> ) at Hopefield in 2006	<b>121</b>
<b>Table 9.1</b>	Historical and current data on yield components over a 21 year period in the Swartland and Southern Cape	<b>130</b>

<b>Table 9.2</b>	Non-linear exponential curves ( $y= A+Br^x$ ) fitted for the number of heads plant <sup>-1</sup> vs. number of plants m <sup>-2</sup> for different cultivars during the 2005 and 2006 season and the average number of heads plant <sup>-1</sup> calculated from 175, 200, and 225 plants m <sup>-2</sup>	<b>134</b>
<b>Table 9.3</b>	Yield <sub>(max)</sub> values for this study calculated with Yield <sub>(max)</sub> = $0.0246x - 1.2376$ at different head populations	<b>136</b>

---



## List of figures

	Page	
<b>Figure 3.1</b>	The DBS Multistream experimental planter	22
<b>Figure 3.2</b>	Action of the seeding unit on the DBS planter	23
<b>Figure 3.3</b>	Placement of fertiliser in relation to the seed	24
<b>Figure 3.4.</b>	Map of localities used for trials included in this study	25
<b>Figure 3.5</b>	Ten day cumulative rainfall (mm) at Riversdale in 2004 and 2006	34
<b>Figure 3.6</b>	Ten day cumulative rainfall (mm) at Swellendam 2004 to 2006	34
<b>Figure 3.7</b>	Ten day cumulative rainfall (mm) at Caledon (2004-2006) and long-term average (1950-2006)	34
<b>Figure 3.8</b>	Ten day cumulative rainfall (mm) at Moorreesburg (2004-2006) and long-term average (1973-2006).	38
<b>Figure 3.9</b>	Ten day cumulative rainfall (mm) at Hopefield 2004 to 2006	38
<b>Figure 3.10</b>	Maximum and minimum temperatures (°C) for 10 day periods (2004-2006) and long-term averages measured at Caledon	39
<b>Figure 3.11</b>	Maximum and minimum temperatures (°C) for 10 day periods (2004-2006) and long-term averages measured at Moorreesburg	40
<b>Figure 4.1</b>	Seedlings counted at the Caledon, Moorreesburg and Hopefield localities in 2005	55
<b>Figure 4.2</b>	Seedlings survival (%) at the Caledon, Moorreesburg and Hopefield localities in 2005	57
<b>Figure 5.1</b>	The influence of row width on the number of heads m <sup>-2</sup> at the Southern Cape localities 2005-2006	64
<b>Figure 5.2</b>	Kernels head <sup>-1</sup> of different cultivars at the Riversdale and Caledon sites in 2006	68
<b>Figures 5.3 a-c</b>	The planting density x row width x cultivar interaction for the number of kernels m <sup>-2</sup> at Swellendam in 2006	69

<b>Figure 5.4</b>	The influence of row width on the number of heads $m^{-2}$ at the Southern Cape localities 2005-2006	<b>70</b>
<b>Figure 5.5</b>	The cultivar x planting density interaction for Thousand Kernel Mass (g) at different planting densities at the Riversdale locality in 2006	<b>72</b>
<b>Figure 6.1</b>	Grain yield ( $ton\ ha^{-1}$ ) for the different cultivars at Riversdale in 2004 and 2006	<b>83</b>
<b>Figure 6.2</b>	Grain yield ( $ton\ ha^{-2}$ ) of the cultivars SST 94, SST 57, SST 88 and SST 015 at the Swellendam site 2004-2006	<b>83</b>
<b>Figure 6.3</b>	Treatment means for grain yield ( $ton\ ha^{-1}$ ) of cultivars (SST 94, SST 57, SST 88 and SST 015) used at Caledon from 2004-2006	<b>84</b>
<b>Figure 6.4</b>	Grain yield ( $ton\ ha^{-1}$ ) at 250 mm and 300 mm row widths at the Swellendam site from 2004 -2006	<b>85</b>
<b>Figure 6.5</b>	Treatment means for grain yield ( $ton\ ha^{-1}$ ) at the 250 mm and 300 mm row widths at Caledon from 2004-2006	<b>85</b>
<b>Figure 6.6</b>	Treatment means for grain yield ( $ton\ ha^{-1}$ ) for the 100, 175 and 250 target (no.) of plants $m^{-2}$ treatments at Caledon from 2004-2006	<b>86</b>
<b>Figure 7.1</b>	Cultivar differences in the number of heads $m^{-2}$ at the Swartland localities in 2005	<b>99</b>
<b>Figure 7.2</b>	Number of heads $m^{-2}$ as influenced by row width (250, 300 and 350 mm) in the Swartland during 2005 and 2006	<b>100</b>
<b>Figure 7.3</b>	Number of heads $plant^{-1}$ as influenced by row width in the Swartland 2005 and 2006	<b>102</b>
<b>Figure 7.4</b>	Number of kernels $head^{-1}$ of cultivars in the Swartland in 2005 and 2006	<b>103</b>
<b>Figure 7.5</b>	Number of kernels $head^{-1}$ as influenced by row width in the Swartland 2005 and 2006	<b>104</b>
<b>Figure 7.6</b>	The number of kernels $head^{-1}$ as influenced by planting density (100, 175, 250 target (no.) of plants $m^{-2}$ ) in the Swartland 2005-2006	<b>104</b>
<b>Figure 7.7</b>	Thousand kernel mass as influenced by planting density (100, 175 and 250 target (no.) of plants $m^{-2}$ ) in the Swartland 2005-2006	<b>105</b>

<b>Figure 8.1</b>	The influence of row width on grain yield (ton ha <sup>-1</sup> ) at Moorreesburg 2004-2006	<b>116</b>
<b>Figure 8.2</b>	Cultivar differences in hectolitre mass (g hl <sup>-1</sup> ) at Moorreesburg 2004-2006	<b>120</b>
<b>Figure 9.1</b>	A scatter plot indicating the relationship between established plants (m <sup>-2</sup> ) and grain yield (ton ha <sup>-1</sup> ) at different localities in the 2005 and 2006 seasons	<b>133</b>
<b>Figure 9.2</b>	Fitted exponential curves for the number of heads plant <sup>-1</sup> against plant populations for different cultivars in 2005 and 2006	<b>133</b>
<b>Figure 9.3</b>	The relationship between head population (number of heads m <sup>-2</sup> ) and grain yield (ton ha <sup>-1</sup> ) at all localities (Riversdale, Swellendam, Caledon, Moorreesburg and Hopefield) during the 2005 and 2006 seasons	<b>135</b>

---

## **Addendums**

Appendixes A to E are in electronic format contained on a CD in an envelope on the back page of this dissertation.

The data is in PDF-format and can be opened with Adobe Acrobat Reader which is available for free on the internet at <http://www.adobe.com>

Each data-set referred to in the in the text can be accessed by clicking on the unique reference number (e.g. A-1) once the document is opened.

Data contained on this CD is supplementary to the results discussed in this dissertation and is not yet interpreted. The copyright and intellectual property of this data belongs to the University of Stellenbosch and the Agricultural Research Council and it may not be cited, used, re-interpreted, presented, reproduced or distributed without the written permission of the University of Stellenbosch and the ARC.

# CHAPTER 1

## INTRODUCTION TO THIS STUDY

The first wheat grown in South Africa was planted in the Cape in the winter of 1652 by the Dutch colonist Jan van Riebeeck (Du Plessis, 1933 as quoted by van Niekerk 2001) and this crop has since then, played an important role in the region's economy. Agriculture in the Western Cape relies heavily on integrated cropping and livestock production systems, as well as fruit and wine production. Wheat, malting barley and canola are the dominant cash crops produced, as these crops are well adapted to the Mediterranean climate of this region. Lupins, triticale, oats and coriander, are also grown on a smaller scale and pastures, like lucern and medics are rotated with cash crops in these production systems. Summer crops like maize and potatoes are not suitable for dryland production in this region but can be produced in the warm, dry summer months if irrigation and suitable soil is available. During the 2006 production season, 37.26% of land planted with wheat in South Africa was in the Western Cape (NDA website, 2007). Production in this region accounted for 33.58% of the total wheat production in the country.

When growing crops in Mediterranean environments, the producer faces specific climatic constraints, not necessarily found in other regions where winter crops are produced. The overall effect of the climatic variation leads to variation in growth period in Mediterranean environments as the growth period available is determined by both the onset of first autumn rain, which determines the start of the planting season and the time of terminal drought which often marks the end of the season. Variable and often deficient rainfall is frequently cited as the most important constraint in these environments (Anderson & Impiglia, 2002). Dry periods late in autumn can delay the onset of the planting season, but the mid-winter period (June to mid - August) is often very wet and waterlogging can be experienced in some soil types if they are not well drained (Loss & Siddique, 1994). During this time, solar radiation is unlikely to limit growth and temperatures usually remain low. However, during periods of high rainfall, extended cloud cover in combination with low temperatures can have a negative impact on crop development and growth.

During early spring (late August and mid September) less frequent rain, combined with higher temperatures and increased demand for water by the plant (which by then will be reaching the end of the vegetative phase), can lead to increased water deficits and subsequently, to water stress (Acevedo *et al.*, 1999). Sufficient supply of resources

(water and nutrients) at this time is critical, especially the period 20 days prior to anthesis to 10 days post-anthesis as severe competition for resources will lead to a reduction in growth rate which will markedly affect the number of grains per unit area (Satorre, 1999). This is the period when yield potential is laid on, finally set and therefore an important period for compensation to earlier setbacks.

Rainfall can be even more erratic during the grain fill period (a few days after anthesis) which usually starts from around the second week of September and therefore intermittent drought periods often occur during this time. Severe competition for water and/or heat stress during this period, will affect grain filling negatively and lead to lower final kernel weight (Slafer, 2007), as 70% to 90% of grain dry weight comes from photosynthate produced during this period (Frederick & Bauer, 1999). By the end of the growing season, when the crop reaches maturity, soil water is almost totally depleted. The last spring rains, temperatures and soil type will determine this period, often referred as terminal drought (Loss & Siddique, 1994). If the onset of terminal drought is early (before the crop reaches maturity), yield loss, due to partially filled grain, is inevitable.

In terms of non-climatic constraints, farmers in Mediterranean climates worldwide often have to deal with shallow calcareous soils, which have little water holding capacity, low and often declining soil organic matter content associated with long-term mechanical cultivation and periodical outbreaks of diseases and insect pests (Anderson & Impiglia, 2002). Similar constraints are experienced in the Western Cape wheat production area where soils often have high stone and gravel contents and are characterised by weakly structured A-horizons (Agenbag & Maree, 1989). Low organic matter content due to the Mediterranean climate (mild winters and very hot, dry summers) and frequent cultivation, is also a characteristic of these soils. According to Wallwork (2002a), general challenges in Mediterranean climates include adequate crop establishment, deciding whether to include or remove livestock, effective pest and disease control, avoiding herbicide resistance and effective handling of crop residues with sowing machinery. In order to make a success of wheat production in Mediterranean-type environments, the choice of a production system that adapts best to these constraints and uncertainties, is an important one. Therefore, much of the wheat agronomy for these environments should deal with practices that maximise water use (Acevedo *et al.*, 1999).

Before the introduction of conservation tillage practices, the cropping system required the removal of crop residues by grazing, baling and burning (Hardy 2008, Personal Communication<sup>1</sup>). Soils were then tilled by using various combinations of ripping,

---

<sup>1</sup> Dr M.B. Hardy. Institute for Crop Production, Western Cape Department of Agriculture

ploughing and scarifying to prepare seedbeds suitable for the planting methods available at the time. The crops were then established in the prepared seedbeds either by broadcasting the seed and fertiliser or by using a variety of planters that made use of coulters and/or discs to place the seed in narrow (175-180 mm) rows. Broadcast seed and fertilizers were usually incorporated into the soil using a scarifier, followed in some cases by a light roller. This process resulted in poor seed placement and poor seed-soil contact. The planters were often not designed to apply fertilisers during the planting process (in which case fertilisers were broadcast) and where they were, the fertilizer was placed together with or in close proximity to the seed. Planters were also not fitted with press wheels and sufficient seed-soil contact were often lacking. The combination of poorly placed seed, insufficient seed-soil contact and fertilisers in close proximity to the seed (fertiliser toxicity) could have been responsible for the low seedling survival rates often reported at the time (Laubscher, 1986; Agenbag, 1992; Maali & Agenbag, 2004).

The implementation of conservation tillage practices is widely accepted as the only available method to improve the long-term sustainability of crop production, as it is effective in reducing soil losses due to wind and water erosion by retaining crop residues which cover and protect the soil (Peiretti, 2007) and at the same time, improving soil water availability. Conservation tillage practices, with the absence of aggressive soil cultivation and the retention of crop residue also helps to improve soil quality by increasing the organic matter content and conservation of soil fauna (Andrade *et al.*, 2003; Franzluebbbers, 2004; Wander, 2004).

As the planting process in conservation tillage systems which implies minimum soil disturbance, stubble retention and the use of effective planters, do not depend on prior tillage operations, it is often possible to establish the crop earlier, making better use of the limited available water and the short growing season in Mediterranean environments. However, the adoption of conservation farming brings new challenges, as the dynamics of the entire system changes. Large scale adoption of conservation tillage can therefore only be achieved if research and development efforts address these challenges and provide the technology needed to overcome them.

Adoption of conservation tillage practices for crop production in the Western Cape is not only driven by the need to improve long-term sustainability, but also by the need to improve on the timeliness with which the crop is established. Producers depend on sufficient autumn rain to proceed with the planting process and want to have as much of the crop established as soon as possible to ensure enough time for the crop to complete its life-cycle and to escape the possibility of early terminal drought. Soil water from the first rain is not lost by cultivation and is therefore utilised more effectively to establish the

crop. Other advantages, such as control of herbicide resistant grasses with crop rotation and application of pre-emergence herbicides during the planting process, also make adoption of conservation tillage systems attractive.

Implementation of conservation tillage methods, which implies the retention of stubble, brings two fundamental changes to the cropping system. In order to manage stubble effectively, the row widths previously used for planting small grain crops with the conventional system, have had to be widened from 175 - 180 mm to at least 250 mm. Although 250 mm is sufficient for planting in light residue and stubble types (like canola) that can be easily handled, any producers report that 275 mm or wider is needed when residue starts to accumulate after remaining in the system for 3-5 seasons. Widening row widths even more, also has economic advantages like reduced initial cost of the planter, more efficient use of fuel, lower draft requirements, shorter planting time and lower maintenance cost (Lafond, 1994). Due to swathing which is practiced widely in the Southern Cape region, row widths wider than 300 mm are not considered feasible, as the loss of grain during harvesting can become too high. These losses may occur particularly in dry seasons when the wide row spacing may not provide an adequate bridge to lay the swath (McLeod *et al.*, 1996). In the Swartland, where the crop is harvested directly, row widths wider than 300 mm could be considered.

Due to the fact that spring wheat cultivars with limited tillering ability are best suited to this environment and growth period, concerns were raised on the possible negative effect that wider row widths could have on grain yield. Amjad and Anderson (2006) reported a general trend towards poorer establishment and seedling survival with increase in row width in cereals. Similar trends were also reported by Anderson (1986) and Del Cima *et al.* (2004), especially when higher planting densities were used in wide rows. These trends were ascribed to increased inter-plant competition for resources as the in-row plant density increases with an increase in row width (Holliday, 1963). The author suggested that the increased inter-plant competition due to crowding in the row in wide row widths (when the same planting density is used) may reduce seedling survival, the number of heads per unit area and kernel weight.

Most research results from Australia (with similar Mediterranean conditions), suggested that reduced yields are almost inevitable when row widths wider than the standard 180 mm are used for cereal crop production (Burch & Perry, 1986; Shackley *et al.*, 2000; Wallwork, 2002b; Amjad & Anderson, 2006). Some results indicated that up to 12% yield benefit could be achieved if even narrower row widths (90 mm) than the standard 180 mm are used (Doyle, 1988). However, Yunusa *et al.* (1993) found no significant effect of row spacing on grain yield in eight experiments over three seasons and concluded that



there is no experimental evidence to support reducing row widths (narrower than 180 mm) for spring wheat in the wheatbelts of Western Australia.

Local results of only one study on the use of wide row widths in the Western Cape was published (Schoonwinkel *et al.*, 1991) and therefore very little information on crop response to wide row widths, the risks involved, or the grain yield penalty to be expected in modern conservation tillage systems, is available. In most experiments involving row widths in cereal crops (Doyle, 1980; Johnson *et al.*, 1988; Schoonwinkel *et al.*, 1991), different row widths were achieved by blocking alternate rows of a normally set planter (175 - 180 mm), doubling the row spacing used (350 - 360 mm). Although this approach does give an indication of the general crop response to widening rows, it does not provide specific information on the narrow range to which no-till planters can practically be set (250 mm - 350 mm) according to Wallwork and Early (2002) and Giumelli *et al.* (2002).

The second fundamental change brought about by the no-till planting method, is that seedling survival rates with the new planters used, could bring a major improvement with regards to survival rates, as seeds are placed more accurately and at uniform depth by the planter. Seedling survival rates with previous planting methods have been low and variable (50-70%) and high planting densities were recommended to ensure sufficient stand. Improved seedling survival rates have the implication that planting density can be reduced without reducing plant population, but seedling survival rates with the new planting method has not yet been determined for a wide range of circumstances in the Western Cape.

The first farmers who adopted conservation tillage principles, accepted possible yield loss as part of the system, but the majority of farmers needed substantial proof that the use of wide rows could be feasible and that the risks are acceptable. For the use of conservation tillage practices to be more widely adopted, a research program, which forms the basis of this study, was developed. This study focuses on the influence of the wide row widths, needed for sufficient stubble handling in conservation farming systems in the Western Cape. As row widths widen, the number of seeds placed in the plant row increases if the same planting density ( $\text{kg seed ha}^{-1}$ ) is used. Similarly, the amount of fertiliser placed in the plant row increases if the same fertiliser rate is applied. These changes in spatial arrangement have important implications, in that plants in the wide rows are more crowded and competition for resources (water and nutrition) between individual plants is increased (Satorre, 1999). Planting densities currently recommended (ARC-Small Grain Institute, 2007), were developed when the crop was sown (with the broadcast method) or planted in narrow (175 - 180 mm) rows with limited competition

between individual plants. When studying the effect of wider row widths and increased crowding associated with it, appropriate planting densities needed consideration. Because cultivars differ in growth period and tillering ability, it was necessary to include at least some cultivars with different growth characteristics, planted at different planting densities, in this study.

Meaningful results from such studies could only be obtained if a wide range of circumstances, caused by different climatic and soil conditions (which are influenced by conservation tillage) were included. Therefore trials used in this study were repeated in five different localities over a three year period.

### **Objectives of this study**

The objectives of this study are the following:

- To quantify the effect of using wide row spacing and different planting densities on seedling establishment, the components of yield, grain yield and quality parameters of spring wheat when the no-till planting method is used within the framework of conservation farming in the Western Cape. This objective essentially answers questions on the yield penalty when very wide row spacing (300 mm) is used instead of 250 mm, which is regarded as the minimum row width that can effectively be used if stubble is retained.
- To revisit planting density recommendations to be used with wider rows than the conventional 175 - 180 mm, with the no-till planting method in conservation tillage systems. Such recommendations will be based on suitable planting density targets for the Winter Rainfall region. Producers can use such target planting densities, TKM of each cultivar and estimated seedling survival % as a guideline to determine appropriate planting density ( $\text{kg seed ha}^{-1}$ ) for each cultivar.

The row width and planting density to be used when planting a crop, are decided by the producer. It is hoped that insights developed by this research will aid farmers to make more informed choices with regards to managing these important practises.

## **Outside the scope of this study**

As the scope of this study is confined to conservation tillage and the no-till planting method, no attempt has been made to compare row widths with the narrow row widths commonly used with conventional planting methods. With only three different cultivars planted at three planting densities, insufficient data is available to determine optimum planting density for a wide range of cultivars. Therefore, only preliminary recommendations of suitable planting densities for no-till planting method in the region will be made for this study.

## **Outlay of this dissertation**

This introduction is followed by a literature review (Chapter 2) and a description of the equipment, trial sites, climatic conditions, cultivars and experimental procedure used in this study (Chapter 3). In Chapter 4, results on seedling survival for both regions will be discussed. The components of yield for the Southern Cape region are discussed in Chapter 5, which is followed by results on grain yield and grain quality parameters for this region (Chapter 6). In Chapter 7, the components of yield in the Swartland region are discussed and grain yield and quality parameters for this region follow in Chapter 8. In the final chapter, new data are compared with historical data and some relationships between the components of yield at all localities in the 2005 and 2006 seasons are discussed and final recommendations are made (Chapter 9). This is followed by a summary of all results and conclusions as well as a complete list of the references cited.

## CHAPTER 2

### LITERATURE REVIEW

This study will investigate the influence of increasing row width and adjustment of planting densities of commonly used cultivars within conservation tillage systems in the Western Cape. In the literature review, a general overview of the use of conservation tillage systems worldwide and in the Western Cape will be given. The review will also include information on the morphological and physiological responses of the wheat crop, in particular responses due to increased competition induced by widening row width and increasing planting density on the components of yield and grain yield itself.

#### **Conservation tillage as a practice**

The practice of establishing crops in un-tilled soil is ancient and was practiced by the Egyptians who created a hole in undisturbed soil with a stick, dropped seeds into the hole and closed it with one foot (Baker, *et al.*, 1996). Such practices are still found in the Upper East Region of Ghana as described by Bonaventure *et al.* (2000), where early millet is planted in a similar way without prior tillage.

According to Lithourgidis *et al.* (2006) modern conservation tillage represents a broad spectrum of farming methods, which are based on establishing crops in the previous crop's residues, purposefully left on the soil surface. The main aim of all these systems is to minimise soil disturbance and to retain crop residues until crop establishment (Wallwork, 2002a). Baker *et al.* (1996) state that the minimum requirement for surface cover by residue in conservation tillage systems is about 30%. The retention of crop residue, which forms the basis of all conservation tillage systems, is therefore the aspect that sets these systems apart from conventional tillage methods in which the residue is purposefully removed or destroyed. Residue retention is responsible for the main advantages of the system, like protection against erosion, improvement of soil biology, water conservation and is undoubtedly more sustainable in the long-term. However, it is also the retention of stubble that causes the most problems and challenges associated with conservation tillage like managing weeds, pests and diseases (Crabtree & Birch, 2002).

Conservation tillage, as an umbrella term, encompasses either reduced tillage where less cultivation than with conventional tillage is applied, or minimum tillage where the aim is to disturb soil as little as possible until the crop is established. Within the practice of minimum tillage, terms such as direct drilling, no-tillage and zero tillage are used, to

describe the amount of soil disturbance when planting. Definitions by Baker *et al.* (1996) and Wallwork (2000a) to explain these terms, are very similar and are presented as follows:

- **Conventional tillage:** Encompasses multiple cultivation passes before sowing for weed control and seedbed preparation.
- **Conservation farming:** The whole farming system aims at conserving soil for sustainable crop production and encompasses minimal tillage and crop residue retention. Crop rotation is always included and part of this concept.
- **Conservation tillage:** At least 30% stubble is retained and can include either reduced or minimum tillage. All conservation tillage methods are less dependent on mechanical cultivation and more dependent on the use of herbicides to control weeds before planting.
  - **Reduced tillage:** Reduced soil disturbance relative to the conventional system. Often (but not always) a tined implement is used prior to planting. Any seeding system with sufficient stubble handling abilities can be used.
  - **Minimum tillage:** The planting process aims to minimise soil disturbance and maximum retention of crop residues and therefore no cultivation prior to planting is performed. Within the concept of minimum tillage, the following planting methods are included:
    - **Direct drilling:** One-pass seeding systems with wide or full cut points for some soil disturbance.
    - **No-tillage:** One-pass seeding systems fitted with narrow points (knifepoint openers)  $\pm 25$  mm in width for minimal (not more than 12%) soil disturbance. The term “no-till” is short for no-tillage, but is not encouraged by purists for grammatical reasons. However it is commonly used to describe this specific method of planting, e.g. “no-till method” or a specialised seeding system e.g. “no-till planter” and is used as such in this dissertation.
    - **Zero-tillage:** One-pass seeding systems using discs or star wheels for minimal soil disturbance and no soil loosening action by penetration of a tine or a knifepoint.

From the above definitions it is clear that terms used to describe tillage and sowing systems within the broader framework of conservation farming, are very closely related and can often be confusing. Definitions differ in different parts of the world and a term such as no-till could describe different systems and approaches. For clarity in this thesis, definitions as described above will be used. These definitions are specific and are based on the action of the planter and the amount of soil disturbance caused.

The advantages and disadvantages of conservation tillage are well cited in literature including books, review articles, scientific publications and guidelines given to producers. A summary of the main advantages, disadvantages and potential problems associated with conservation tillage systems are given in Table 2.1.

**Table 2.1** Advantages, disadvantages and potential problems experienced with the use of conservation tillage

<b>Advantages of conservation tillage</b>	
Prevents soil degradation by protecting soil with crop residues (reduced water and wind erosion).	Kirkegaard,1995; Baker <i>et al.</i> , 1996; Blackshaw, 2002; Malinda & Wallwork, 2002; Murphy, 2002; Wallwork, 2002a; Peiretti 2007
Improves soil structure by retaining organic matter and reducing soil breakdown due to cultivation.	Kirkegaard,1995; Baker <i>et al.</i> , 1996; Wallwork, 2002a; Peiretti, 2007
Promotes growth of soil organisms and biodiversity.	Baker <i>et al.</i> , 1996; Chan & Heenan, 2002; Roper & Gupta, 2002; Wallwork, 2002a; Peiretti, 2007
Improves use of soil water storage by better infiltration and less evaporation and run-off.	Baker <i>et al.</i> , 1996; Andreini, 2002; Radford & Chudleigh, 2002; Wallwork, 2002a
Decreases labour and machinery costs and improves profitability.	Baker <i>et al.</i> , 1996; Blackshaw, 2002; Brennan & Wallwork, 2002; Wallwork, 2002a; Lithourgidis <i>et al.</i> , 2006
Improves timeliness of operations. Less operations needed and shorter standing time in wet conditions.	Baker <i>et al.</i> , 1996; Wallwork, 2002a
Increases energy efficiency and fuel conservation	Baker <i>et al.</i> , 1996
Increases the effectiveness of machines and capital outlay. Planters usually handle a variety of crops.	Baker <i>et al.</i> , 1996; Wallwork, 2002a
Improves economical sustainability in the long-term.	Wallwork, 2002a
Improves nutrient availability in the long-term.	Wallwork, 2002a
Potentially improves crop yields due to soil improvement and improved water use.	Wallwork, 2002a
Stubble retention can aid weed management by preventing light reaching the seedbed and reducing weed seed germination. Weed seeds remain in the top soil layer.	Baker <i>et al.</i> , 1996; Minkey & Walker, 2002
More options available to control weeds within the crop rotation system and with pre-emergence herbicides.	Minkey & Walker, 2002
Reduces emission of “greenhouse” gasses.	Newton, 2002
Reduces run-off and reduces pollution of waterways.	Baker <i>et al.</i> , 1996
Improves trafficability, untilled soil resists compaction by traffic and animals.	Baker <i>et al.</i> , 1996
More management and recreation time.	Baker <i>et al.</i> , 1996
<b>Disadvantages and potential problems</b>	
Reduces yields, especially in initial stages and may even cause crop failure. Grain yields of cereal crops may also be reduced due to wider row widths needed for stubble clearance.	Schoonwinkel, <i>et al.</i> , 1991; Baker <i>et al.</i> , 1996; Shackley <i>et al.</i> , 2000; Wallwork 2002b; Amjad & Anderson, 2006
Increases weed competition between rows due to wider rows used.	Wallwork, 2002b

Increases risk of fertiliser toxicity due to wider rows.	Wallwork, 2002b
More difficulties experienced when swathing cereals.	Wallwork, 2002b
Difficulties to integrate livestock due to compaction and loss of residue cover.	Buckley, 2002; Brennan & Wallwork, 2002; Wallwork, 2002a
Retained stubble can lead to outbreaks of pests and greater incidence of diseases. Different pest and disease control strategies need to be employed.	Kirkegaard, 1995; Baker <i>et al.</i> , 1996; Wallwork, 2002a; Tribe, 2007
High capital cost of no-till machinery can reduce viability. Often a large tractor and planter needs to be acquired or equipment must be adapted.	Baker <i>et al.</i> , 1996; Brennan & Wallwork 2002
Shift in dominant weed species. Some problem weeds can become more difficult to control.	Baker <i>et al.</i> , 1996; Derkson, 2002; Wallwork, 2002a
Some crops tend to have slower early growth making them more vulnerable to pests and insects. Root development can be impaired by biological factors.	Kirkegaard,1995; Baker <i>et al.</i> , 1996; Reeder, 2002; Wallwork, 2002a; Wallwork & Heenan, 2002; Carr <i>et al.</i> , 2003
High dependence and over-reliance on herbicides and pesticides can affect gross margins negatively and accelerate herbicide resistance.	Baker <i>et al.</i> , 1996; Brennan & Wallwork 2002a; Minkey & Walker, 2002; Storrie, 2002
Allelopathic effect of retained crop residue can have negative influence on growth of subsequent crops.	Purvis, 1990; Kirkegaard,1995; Pratley, 2002
Conservation tillage can lead to faster acidification of soil.	Heenan & Conyers, 2002
Untidy appearance of fields.	Baker <i>et al.</i> , 1996

Herbicide resistance, resulting in the inability to control weeds with available herbicides is recognised as one of the biggest threats to modern day conservation tillage (Storrie, 2002). An integrated approach, including non-chemical means of weed management is seen as critical to ensure the sustainability of conservation tillage systems. Serious cases may involve drastic measures such as strategic burning of stubble and even cultivation as a last resort. Uncontrollable outbreaks of diseases and pests can be equally threatening to sustainable conservation farming. Once again, crop rotation and integrated control measures are considered critical in managing these problems (Crabtree & Birch, 2002; Wallwork, 2002c).

While conventional cropping systems have been practised for many decades (even before the development of modern farming equipment) and are well known, modern conservation tillage as practiced today, is relatively young. The notions that farmers should adopt some form of conservation strategy to curb the loss of soil, reduce energy inputs and prevent run-off pollution of waterways were born in the thirties (Purvis, 1990) and development of current no-till systems started in the sixties (Baker *et al.*, 1996). However, farmer-experience at the time suggested that adopting such techniques would result in a greater short-term risk of reduced seedling emergence, reduced yield and even worse, crop failure. In Argentina and other South American counties where high

rates of adoption of conservation tillage are currently experienced, research on these systems started in the early seventies, but adoption only boomed by the mid-eighties and early nineties (Peiretti, 2007). In the Americas, the utilisation of new technologies and approaches such as more specific use of agro-chemicals, integrated methods to control weeds, diseases and insects, development of specifically adapted genotypes and the successful development of no-till planters are considered to be the factors that allowed the practical implementation and evolution of conservation tillage systems.

Despite the challenges posed by adoption in Australia, a national agriculture survey by the Kondinin Group in 1998, showed that 88% of broad-acre farmers were establishing crops with less tillage than they had in the past (Wallwork, 2002a). Prior to 1990 farmers in the Western Cape were tempted to change to conservation tillage practices but they generally had little success due to mechanical difficulties caused by inadequate seed placement and poor seed cover, higher bulk densities and soil strength and reduced mineralisation (Agenbag & Maree, 1991). Wallwork and Heenan (2002) stress the importance of uniform plant establishment and optimum planting density in one-pass planting systems such as zero tillage, no-tillage or direct seeding operations. In order to maximise yields, the seed must be placed at uniform spacing and depth into moist soil with good seed-soil contact. When seedling growth is vigorous, the ability of crops to withstand pests, weeds, disease and decreasing soil moisture increases. These authors report that farmers in New South Wales (NSW) recorded a reduction in early vigour of wheat seedlings under no-tillage and that this trend was found at 62% of sites in a recent survey, where seedling vigour was reduced with an average of 20% at the three leaf stage. Another study quoted by the authors recorded a 65% reduction in biomass of no-till wheat six weeks after sowing in light and heavy soils in Southern NSW and Northern Victoria. No clear explanation for this phenomenon is given, but the authors argue that increased populations of soil micro organisms that restricted root growth and reduced nitrogen availability may be the cause. It has also been suggested that this problem is more likely to occur in cool moist soil, typical of the no-till system (Carr *et al.*, 2003). An early setback in growth and dry matter production can persist through to flowering but this is not always the case.

According to Wallwork and Heenan (2002) the main factors that influence vigour and early development of seed are soil moisture conditions, temperature and crop rotation and they state that increased timeliness of sowing is the best strategy to offset the possible loss of vigour and reduced early growth. Accurate placement of seed at uniform depth and placing of fertiliser away from the seed can also improve seedling survival and vigour (Rainbow, 2002).



## **Crop response to spatial arrangement**

It is generally believed that wheat growth and development is an integration of the processes of plant water relations, nutrient uptake and metabolism, photosynthesis and respiration, carbon partitioning and leaf senescence (Frederick & Bauer, 1999). Climatic conditions, soil conditions and practices used to produce the crop, can alter these processes at different times during the season and therefore influence growth and development, the components of yield and eventually grain yield itself.

The response of wheat plants to planting density and changes in spatial arrangement is largely determined by the ecological process of competition which occurs when resources like mineral nutrients, water and light are insufficient to cater for the joint requirements of plants (Holliday, 1963; Satorre, 1999). The negative effect of competition can be temporary or permanent and it can reduce seedling emergence and survival, plant growth and development, grain fill and ultimately grain yield. Wheat plants under density stress, due to crowding either by planting densities above the optimum, or induced by the in-row competition, will be smaller, tiller less and will produce less grain per unit area. A squire (grid-like) rather than a rectangular planting pattern (planting in rows) will result in more efficient use of limited resources for a given area by delaying the time of leaf and root zone overlap from neighbouring plants (Holliday, 1963). In an experiment where wheat was broadcast by hand in a wide range of planting densities, Puckridge and Donald (1967) found that germinating seedlings were non-competitive at all planting densities during the first four weeks after planting. They did however state that if seedlings were crowded into rows, competition between seedlings could be expected much earlier.

The most popular crop physiological way to understand yield from simpler attributes is by the yield component approach which divides grain yield into two major numerical components, the number of kernels  $m^{-2}$  and the average individual kernel weight (Slafer, 2007). The number of kernels  $m^{-2}$  can then be divided into various sub-components such as plants  $m^{-2}$ , number of tillers  $plant^{-1}$ , number of heads  $m^{-2}$ , number of heads  $plant^{-1}$ , number of kernels  $head^{-1}$ , number of spikelets  $head^{-1}$  and number of kernels  $spikelet^{-1}$ .

The overall number of kernels  $m^{-2}$  is determined by the number of head bearing tillers  $m^{-2}$  (tillers with fertile heads) multiplied by the average number of kernels  $head^{-1}$  (Frederick & Bauer, 1999). The number of head bearing tillers is influenced by tiller initiation and survival, the type of wheat (winter or spring) cultural practices (such as planting density, growth period available, soil fertility) and growing conditions (air and soil temperatures and water availability). In the first instance, the number of fertile heads

depends on the number of initial tillers that survive to become head bearing. When the wheat plant grows in the absence of competition (virtually unlimited resources in relation to demands) as experienced for a short period if favourable conditions prevail in the beginning of the growing season, a large number of tillers will be initiated in relation to the number of leaves that forms (Miralles & Slafer, 1999). Later, when competition sets in, resources become limited and new tillers stop appearing. If resources remain insufficient to maintain tillers already formed, some tillers will die in the reverse order in which they were formed.

Tiller mortality usually coincides with the beginning of stem elongation, when there is a sharp increase in demand for resources and assimilates. Increased inter-plant competition, as induced by high seeding rates, will decrease the number of head bearing tillers per plant as pointed out by Puckridge and Donald (1967), but not the total number of heads per unit area within a certain range of planting densities (a term referred to as plasticity). With increasing row widths, at the same seeding rate, the competition between plants increases and therefore a reduction in head bearing tillers can be expected, which will result in fewer heads per unit area (Johnson *et al.*, 1988).

While older cultivars produce many tillers and sub-tillers with low survival rate (35%), modern spring wheat cultivars adapted to Mediterranean environments, produce only primary tillers associated with the first two or three leaves, but have much higher survival rates of about 50% (Loss & Siddique, 1994). Anderson and Barclay (1991) found tiller mortality to vary between 22% and 46% for different cultivars planted at different localities and seasons in the Mediterranean climate of Western Australia.

The second important component in determining the total kernels per unit area is the number of kernels head<sup>-1</sup> which is the product of a large increase in the number of potential sites (floret primordia) which develop to bear grain, followed by a dramatic reduction in these numbers ('floret mortality') until achieving the final number of fertile florets and subsequently the number of kernels head<sup>-1</sup> (Slafer, 2007). The process of floret mortality coincides with the onset of rapid growth of stems and heads and ends at anthesis. The final number of fertile florets (therefore the number of kernels head<sup>-1</sup>) is determined by the rate of floret mortality, which is determined by the competition for assimilates by the head. Increased competition for resources at this time (such as competition induced by in-row crowding) can increase floret mortality and reduce the number of kernels head<sup>-1</sup>.

Once the final number of kernels m<sup>-2</sup> (the product of heads m<sup>-2</sup> and kernels head<sup>-1</sup>) has been established, the final yield can only be further influenced by the average weight of

individual kernels (Johnson *et al.*, 1988). Kernel weight is therefore considered an important, but independent factor that can affect the final yield of winter cereals. According to Slafer (2007) the period immediately following anthesis and ending at the onset of rapid grain growth (the lag phase) seems to be of paramount importance in determining final kernel weight. Water and heat stress after anthesis, therefore often have a detrimental effect on wheat grain yield by reducing kernel weight (Schwarte *et al.*, 2006). Anderson and Barclay (1991) reported interactions with regard to kernel weight by some cultivars, which responded differently to increases in planting density in Western Australia. Johnson *et al.* (1988) found that some cultivars could compensate for reduced number of heads  $\text{m}^{-2}$  by increased kernel weight.

### **Seedling survival**

It is widely accepted that sufficient number of heads per unit area (head population) is the most important component which can be controlled by cultural practises to optimise the grain yield response of wheat crops (Satorre, 1999). Sufficient head populations can be achieved by ensuring that a sufficient number of seedlings survive and that sufficient resources (water and nutrients), to sustain early growth and development, are supplied. Establishment of sufficient plant populations and therefore heads per unit area, by ensuring sufficient plant establishment, has always been a priority in wheat production in the Western Cape (Laubscher, 1986; Schoonwinkel *et al.*, 1991; Agenbag, 1992). During the mid-eighties when conventional planting methods were almost exclusively used in the Western Cape, seedling survival was considered to be only 50% (Laubscher, 1986). High planting densities (up to 160 kg seed  $\text{ha}^{-1}$ ) were recommended (Agenbag, 1992) to achieve sufficient plant establishment and head populations as spring wheat cultivars have limited tillering ability and growing conditions are not always conducive to tillering, especially if the growing season starts late due to inadequate autumn rainfall.

In a more recent study by Maali and Agenbag (2004) on the effect of soil tillage, crop rotation and nitrogen fertilisation of wheat in the Swartland, the authors found seedling survival percentages of 61% and 72% in the 2000 and 2001 seasons respectively, but found no significant differences in seedling survival between the tillage methods, including conventional and conservation tillage. As a general rule of thumb, survival percentage is still considered 50% for the broadcast method and 60-70% for conventional planters in the Western Cape (Agenbag 2008, Personal Communication<sup>2</sup>).

The effect of row width on seedling survival is not often reported in literature, but Schoonwinkel *et al.* (1991) did report that on average, row width did not influence

---

<sup>2</sup> Prof. G. A. Agenbag. Dept. of Agronomy, University of Stellenbosch.

seedling survival significantly over a three year period in a study at Langewens in the Swartland. These results agree with the findings of Yunusa *et al.* (1993) who found that seedling survival was not negatively influenced by increasing row width in two experiments in the wheat belt of Australia. At one of these sites where the soil surface was sealed after heavy rain and crop emergence generally reduced, seedling survival percentage was found to be lower at the high planting density than at the lower planting density. Due to more inter-plant competition created with wide row widths, it would be safe to assume that seedling survival could be more negatively effected in wide rows if severe stress conditions are experienced after planting.

Reduction of seedling survival and loss of early vigour are commonly listed as major disadvantages of conservation tillage systems world-wide (Baker *et al.*, 1996; Wallwork & Heenan, 2002) but in the Western Cape, it is perceived that seedling survival with the use of no-till planters, has dramatically increased in comparison with the broadcast planting method and wheat planters used in conventional systems. This perception has lead to the reduction of seeding rates by as much as 20-30% from the normally recommended 100-140 kg ha<sup>-1</sup>.

### **Altering spatial arrangement by increasing row width**

A row width of 180 mm is considered to be the normal or standard row spacing for broad-acre, rain-fed crops and spacing greater than 180 mm is considered wide row spacing in wheat-based cropping systems in Australia (Amjad & Anderson, 2006; Wallwork, 2002b). Similarly, 175 mm row spacing is considered standard for conventional cereal-based cropping systems in the winter rainfall region of South Africa (Schoonwinkel *et al.*, 1991). Wide row spacing (Doyle, 1980), along with vertical clearance, are the two components necessary for improving the stubble handling ability of the no-till planter (Wallwork & Early, 2002). In conservation tillage systems, where stubble is maintained, there is no other option than to use wider row spacing than in conventional systems. Modern no-till planters vary in row width from 225 to 300 mm. According to Giumelli *et al.* (2002), row spacing of 285 mm or more, will ensure good stubble flow in most situations.

According to various studies in Australia, the USA and elsewhere, grain yield of wheat is often sacrificed with the use of wider rows (Holliday, 1963; Doyle, 1980; Frederick & Marshall, 1985; Burch & Perry, 1986, Marshall & Ohm, 1987; Johnson *et al.* 1988; Shackley *et al.*, 2000; Newton, 2002). However, some winter wheat studies, mostly executed in temperate environments, found no adverse affects with regard to grain yield in many experiments when row widths wider than the normal practise (usually 180 mm)

were used (Crabtree & Rupp, 1980; Lafond, 1994; McLeod *et al.*, 1996; Lafond & Gan, 1999; Hiltbrunner *et al.*, 2005).

In Mediterranean environments where terminal drought is common, early canopy closure is often associated with rapid depletion of soil moisture reserves, in which case yield may be limited by a lack of soil moisture during the post anthesis period (Rickert *et al.*, 1987). Yunusa *et al.* (1993) argues that when a crop depends on stored soil moisture for a considerable time of its lifespan, rapid canopy closure by reduced row width may lead to insufficient water availability towards the end of the growing season and therefore reduce yield. He suggests that canopy closure is restricted in such circumstances by using wider row widths. However, when yield can be advantaged by sustained early canopy closure (in situations where water supply is stable throughout the growing period) the use of narrow row widths will be beneficial.

Wallwork (2002b) reports that in 50 experiments carried out throughout Australia, increasing row spacing from 180 mm to 230 mm reduced wheat yield by an average of 4%. Research in Western Australia showed an average yield penalty of 1.5% for every 25mm row spacing increase above 180 mm. Based on these results it was calculated that converting machinery from 180 mm to 300 mm would reduce wheat grain yield by 7%. A potential 2 ton ha<sup>-1</sup> yield will then be reduced by 140 kg ha<sup>-1</sup>. If this prediction is applied to row widths which shift from 250 mm to 300 mm (50 mm) the expected yield reduction will be in the order of 3%.

In a local study, Schoonwinkel *et al.* (1991) reported that wider row spacing influenced grain yield positively in the below average 1986 season and negatively in the above average 1987 season. The authors came to the conclusion that this reduction was caused by greater in-row competition in the wider row spacing, which reduced the number of heads per unit area, and subsequently grain yield.

### **The relationship between planting density and grain yield**

The response of grain yield to variations in planting density is likely due to factors such as seasonal rainfall, soil physical properties, nutrient supply, planting time and the genetic make-up of the cultivar (Del Cima *et al.*, 2004). According to Anderson (1986) the optimum planting density range for crops with terminal inflorescences and a large capacity to produce culms such as wheat, is often very wide. Ciha (1983) showed that for spring wheat, increasing planting density did not increase grain yield except when the crop was planted late and when environmental factors reduced tillering.

Anderson and Impiglia (2002) emphasise that, to ensure that the plant population is not a limiting factor, the optimum plant population of wheat is proportional to the yield level and that planting density should therefore be increased when higher grain yield is expected. Planting density experiments by Anderson *et al.* (2004) indicated that optimum plant populations in Australia could vary between 35 to 175 plants m<sup>-2</sup> for average grain yields of 0.42 to 3.91 ton ha<sup>-1</sup> and that Australian farmers should aim to establish a minimum of 40 plants m<sup>-2</sup> for every ton of grain yield expected, up to a yield level of 3 ton ha<sup>-1</sup>. Another 50% must be added as a safety margin and to compete with weeds, resulting in a target planting density of 180 established plants m<sup>-2</sup> for this yield level.

According to Anderson *et al.* (2004), grain yield is seldom reduced if planting densities higher than the optimum are used, and therefore erring to the high side of the optimum is usually not detrimental to grain yield or quality and may even be advantageous in creating competition for weeds. However, erring to the low side of optimum planting density can cause a substantial reduction in yield, especially in fields with weed problems, as the crop will not be able to compete against weeds effectively.

In South Africa, experiments during the period 1986-1989 by Fouche and Schoonwinkel (1991), included 28 planting density trials. In these trials, grain yield did not vary significantly with plant populations of 165-280 plants m<sup>-2</sup>. Work by Laubsher *et al.* (1991) similarly found that grain yield at the Malmesbury locality in the Swartland did not increase as planting density increased from 190-293 plants m<sup>-2</sup> at a yield level of 4.19 ton ha<sup>-1</sup>. At the Dughye Park locality in the Southern Cape, an increase of 175 to 254 plants m<sup>-2</sup> increased yields only slightly from 3.2 to 3.3 ton ha<sup>-1</sup> but yield was reduced to 2.67 ton ha<sup>-1</sup> when plant population was further increased to 327 plants m<sup>-2</sup>. Similar research with the cultivar Palmiet at three localities; Pools (Northern Swartland), Langewens Research Station (central Swartland) and Tygerhoek Research Station in the Central Southern Cape indicated that grain yield increased with increases in plant population up to 278 plants m<sup>-2</sup> (Smit *et al.*, 1991). Agenbag (1992) summarised research on planting density of wheat in the Western Cape during this period and concluded that 200-230 plants m<sup>-2</sup> in high potential areas and 150-175 plants m<sup>-2</sup> in marginal potential areas should be sufficient to reach the yield potential for the different production areas.

Previously, guidelines for planting density were based on research done for conventional planting methods (broadcasting or sowing in narrow rows) in prepared seedbeds. For most cultivars used in this region, current planting density recommendations require 100-140 kg seed ha<sup>-1</sup> (ARC-Small Grain Institute, 2007). These recommendations do

not cater for yield potential, kernel weight (Thousand Kernel Mass, TKM) or an estimate of survival percentage and are mostly based on observations and research done by owners of the cultivars during the development phase. All recommendations pertaining to optimum planting dates and planting density are subject to approval of the National Cultivar Evaluation Committee, which reviews recommendations annually. Recommendations as currently used in South Africa, are based on the principle of erring to the high side of optimum planting density.

The major shortcoming of this approach (not taking TKM and seedling survival into account when recommending planting density), is that the actual number of seeds placed  $\text{m}^{-2}$  will vary from cultivar to cultivar and season to season. A recommendation of  $100 \text{ kg ha}^{-1}$  for a cultivar with a TKM of 36 g will result in 277 seeds  $\text{m}^{-2}$  being placed. The same recommendation, and cultivar with a TKM of 40 g, 250 seeds  $\text{m}^{-2}$  will be placed, while a cultivar with a TKM of 50 g will have only 200 seeds  $\text{m}^{-2}$  placed. As seed weight that farmers use, typically varies from 36-50 g 1000 kernels $^{-1}$ , the number of seeds placed can thus vary from 200-277 seeds  $\text{m}^{-2}$  for the same  $100 \text{ kg seed ha}^{-1}$  recommendation. If the current norm of 60% seedling survival is applied, it will mean that only 120-166 seedlings  $\text{m}^{-2}$  will survive. If seedling survival can be increased to 80% it will mean that 160-221 will survive. In practice, this could mean that when planting seed with high TKM, plant establishment could be very close to the minimum or even below for high potential situations. Del Cima *et al.* (2004) suggested that greater accuracy in choosing plant density is desirable and that it should be done on the basis of a target plant population according to yield potential of the area or even the specific season. According to Anderson and Barclay (1991) the variation of optimum planting density between seasons is far greater than variations between cultivars in rainfed Mediterranean environments.

Producers have traditionally regarded the cost of seed as only a small fraction of the total production cost, especially when own seed is kept from one season to the next. Therefore the low risk strategy of erring to the high side of optimum planting density has paid off and remained in use for decades. With profit margins shrinking, reducing planting densities to the optimal is seen as a practical way to reduce the cost of production. Using less seed, without compromising grain yield, will have definite cost benefits, especially when new, relatively expensive seed, is purchased to replenish own seed stocks or to introduce new cultivars. Modern planters are easily calibrated, very accurate and planting density can be precisely controlled. Farmers are much more aware of managing planting density and are now able to use more specific recommendations in this regard.

### **The interaction between cultivars, row width and planting density**

Various interactions of the factors cultivar, row widths and planting densities are cited in literature for the components of yield and grain yield itself, but for this review, only some of the findings for the main component, grain yield will be highlighted. Ciha (1983), reported significant cultivar x planting density interactions for spring wheat, but no significant interactions between cultivars and planting density were found for spring wheat cultivars in the central wheat belt of Western Australia (Anderson & Barclay, 1991).

When studying the interaction between 16 winter wheat cultivars, planting densities and row widths, Marshall and Ohm (1987) found significant interactions for row widths and planting densities in two seasons. From these results the authors concluded that a combination of narrow row widths and high planting densities is needed to improve grain yield. In contrast with these findings Johnson *et al.* (1988) found no interaction for the above mentioned factors for soft red winter wheat in the north-eastern and mid-Atlantic of the USA. Yunusa *et al.* (1993) also found no significant interactions between row widths and planting densities on growth, grain yield and water use of spring wheat, indicating that these factors functioned independently in the dry Western Australian environment. Lafond (1994) found significant row width x planting density interactions for grain yield of spring wheat in Canada in only 2 out of 12 experiments in Canada. For winter wheat, Lafond and Gan (1999) found significant row width x planting density interactions in 2 out of 3 trials and concluded that there is no need to change planting density when row width is changed. In the local study by Schoonwinkel *et al.* (1991) significant planting density x row width interactions were also found which indicated the highest grain yield with the narrow row width (175 mm) at a medium planting density of 75 kg seed ha<sup>-1</sup> for a spring wheat cultivar in the Swartland region of the Western Cape.



## CHAPTER 3

### DESCRIPTION OF APPROACH, EQUIPMENT, TRIAL SITES, CLIMATIC CONDITIONS, CULTIVARS AND EXPERIMENTAL PROCEDURE

#### Introduction

It was clear at the onset of this study that basic agronomy issues within a new cropping system, which differed in many ways from the conventional system, had to be dealt with. Therefore a new approach and equipment similar to that used by farmers, was needed to develop an appropriate research program that would yield results directly applicable to farmers' needs. This chapter will describe the approach followed, equipment, trial sites and the experimental procedure used.

#### On-farm field trial approach

All trials presented in this study were planted in wheat fields of producers within well-established crop rotation systems. It was decided at the onset of this study to follow an on-farm approach in order to ensure that data collected was representative of what would happen in reality. Although this approach has shortcomings and limitations, it ensures farmer participation and ownership as well reduces the "yield gap" often found between yields in on-station experiments and general yields in the area. The yield gap can often be attributed to high levels of management and inputs (fertiliser, herbicides, insecticides and fungicides) used in on-station experiments in order to keep experimental conditions optimal. This approach required that all management decisions such as fertiliser top dressing and weed control were left to and applied by the farmer, but research activities such as planting, harvesting and data collection were done by the research team. With this approach it was possible to ensure that localities were representative of specific production areas and that many seasons could be included within crop rotation systems. One of the drawbacks to this approach was vulnerability to accidental damage by animals and farmers' implements, as the trials were part of the producers wheat field and were not secured by fencing. Due to the high level of decision making needed by the farmer, only farmers experienced in conservation tillage systems and with high levels of management skills were selected to participate in these experiments.

### Planting equipment used

Trials on all localities and in all seasons were planted with the same commercially available planter, which was especially adapted to be used for experimental sized plots. The planter technology used was derived from imported no-till technology sold under the name “Auseeder” in Australia. In South Africa the same technology with imported seeding units was sold under the brand name DBS-Multistream (Figure 3.1). The experimental size DBS-Multistream planter is fitted with an airseeder product delivery system, similar to systems used in many commercial planters. An onboard computer controls the application rates of seed and fertilisers at predetermined rates as selected by the operator during the planting operation. Calibration of products is done by determining a sample weight for 1800 simulated wheel pulses and calculating a calibration factor (pulses  $\text{kg}^{-1}$ ) for the product. The computer uses the calibration factor, the planter width and the speed of the planter (determined by the wheel pulses) to adjust the application rate, via a hydraulic system, to the required application rate in  $\text{kg ha}^{-1}$ . The planter is fitted with three mass storage bins, one for seed, two for fertilisers and a tank for liquids. Different channels on the computer control the application rate of each of these bins separately.



**Figure 3.1** The DBS Multistream experimental planter. (Source: ARC-Small Grain Institute)

The DBS (Deep Blade System) seeding units are designed to apply seed and fertiliser accurately at uniform depth with minimal soil disturbance and maximum stubble handling. Stubble handling is enhanced by placing seeding units on two parallel bars, spaced 2 m from each other, doubling the distance between two seeding units on the same bar. The front bar is fitted with three seeding units and the rear bar with four, providing seven rows with row widths of 250 mm or 300 mm. Different row widths are set by physically moving each seeding unit on the bar to the desired setting. To set the row spacing to 350 mm, two seeding units have to be removed and thus only 5 rows are available.

The seeding unit consists of a tine fitted with a knifepoint opener to loosen the soil and band place fertiliser below the seed (Figure 3.2). This slot is closed by a closing tool, which also “prepares a seedbed”. The closing tool and press wheel are fitted by parallelogram directly to the rear of the tine and seed is placed into the soil just behind the closing tool and covered by a “wave” of soil pushed forward by the press wheel. The press wheel ensures sufficient compaction of soil around the seed. The DBS system uses a soft rubber press wheel (70 mm wide) with a flat profile.

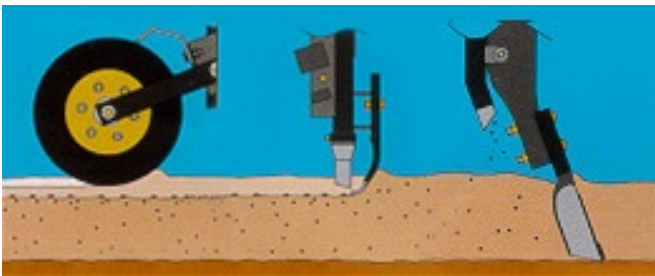

**Figure 3.2** Action of the seeding unit on the DBS planter. (Source: Ausplow)

Different fertiliser placements are achieved by changing the proportion of fertiliser entering each of the two air streams of the airseeder mechanism. One air stream only carries fertiliser and applies it to the rear of the knifepoint, band-placing it below the seed. The other air stream carries the seed and places it in the seed slot just behind the closing tool on the “seed bed” prepared by the closing tool. Fertiliser entering this air stream will be placed in close proximity to the seed. Changing the proportion of fertiliser in each air stream is done by changing the setting of a lever at the entry points of each air stream. Fertiliser placements as used in this study are depicted in Figure 3.3. In all trials in this study, the setting which places 25% of fertiliser with the seed, was used.

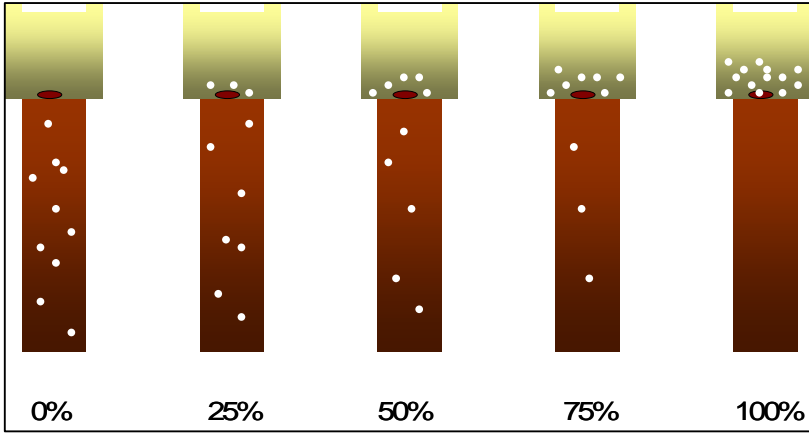

**Figure 3.3** Placement of fertiliser in relation to the seed. (Source: ARC-Small Grain Institute).

### Description of the trial sites

Field trials were conducted at three localities in the Southern Cape region of the Western-Cape (Riversdale, Swellendam and Caledon) and two localities in the Swartland (Moorreesburg and Hopefield) during the period 2004 to 2006. Each locality, the seasons included in this study, geographical position and previous crop are presented in the map (Figure 3.4) and Table 3.1. Localities were chosen to represent different production potentials, climatic conditions and soils found in each region. Localities were also selected based on the crop rotation system followed and the expertise and experience of the farmer in managing conservation tillage systems.

### Riversdale

The Riversdale locality situated in the Riversdale Flats, is unique in this region because of its flat topography. The geographical position of this site is shown in Figure 3.4. The soil is classified (Soil Classification Working Group, 1991) as a Glenrosa 2122 with a non-red B horizon (Table 3.2). The A-horizon (top soil layer) is very shallow (20 cm) has a sandy loam texture and very high stone and gravel fraction of 50%. This horizon therefore has a low to moderate water holding capacity. The lithocutanic B-horizon (a mixture of soil, partially weathered and un-weathered shale) is up to 60 cm deep. Some soft, weathered shale in this horizon may be penetrated by the roots which will enhance the water holding capacity of the profile. Average soil carbon content at this site is fairly high at 1.4% (Table 3.3). Soil analysis indicate that the soil has very high pH levels ( $\text{pH}_{(\text{KCl})} = 7.20$ ) with high, above optimum, calcium levels ( $4040 \text{ mg kg}^{-1}$ ) and optimum Mg ( $183 \text{ mg kg}^{-1}$ ) levels (Fertilizer Society of South Africa, 2003). With the high Ca levels the proportion of Ca to Mg (Ca : Mg = 13.4) is abnormally high.



**Figure 3.4.** Map of localities used for trials included in this study. (Source: ARC – ISCW)

These high levels of calcium can also be visually seen as limestone outcrops in vicinity of the trial. Levels of P (79 mg kg<sup>-1</sup>, Citric acid) and K (344 mg kg<sup>-1</sup>) can be considered high and Na levels (49 mg kg<sup>-1</sup>) as medium-high. The previous crop at this site was always canola (Table 3.1). Crop rotation and reduced tillage practised at the site for seven seasons before starting with these trials.

**Table 3.1** Localities, farm name, latitude\*, longitude and previous crop for each locality used in the Western Cape for the seasons 2004-2006

<b>Locality</b>	<b>Farm name</b>	<b>Latitude</b>	<b>Longitude</b>	<b>2004</b>	<b>2005</b>	<b>2006</b>
Riversdale	Uitkyk	-34.18357	21.16569	Canola	-	Canola
Swellendam	Middeldrif	-34.25934	20.43963	Lupin	Lupin	Canola
Caledon	Heuningneskloof	-34.24910	19.58560	Canola	Canola	Canola
Moorreesburg	Klein Swartfontein	-33.16953	18.72105	Medics	Medics	Medics
Hopefield	Karbonaaitjieskraal	-33.11195	18.43009	Lupin	Lupin	-
Hopefield	Waterboerskraal	-33.05102	18.41580	-	-	Lupin

\*Geographical data given in decimal degrees. (-) Locality not used.

### ***Swellendam***

The Swellendam site, which is situated between the mountain range and the ocean in the Napkei valley, was chosen as a low potential site due to its shallow soils and low, erratic rainfall. The trial site is situated on the mid-slope of a north-facing ridge. The soil is classified as a Glenrosa 2112 with a non-red B horizon (Table 3.2). The A-horizon is very shallow (20 cm) and has a sandy loam texture with a stone and gravel fraction of 40% with a low to moderate water holding capacity (Table 3.2). The lithocutanic B-horizon consists of 70-80% hard shale with very limited water holding capacity as it cannot be penetrated by roots. The soil carbon content is fairly high at 1.4% (Table 3.2). The pH of the soil at this locality (Table 3.3) is well within the norms for wheat production (Fertilizer Society of South Africa, 2003) in the slightly acid category ( $\text{pH}_{(\text{KCl})} = 5.57$ ) with fairly high levels of P (55 mg kg<sup>-1</sup>, Citric acid). Ca and Mg levels (900 and 256 mg kg<sup>-1</sup>) with are normal with a normal Ca : Mg ratio of 2.14. The level of K (178 mg kg<sup>-1</sup>) at this site is higher than optimum and Na level is exceptionally high at 155 mg kg<sup>-1</sup>. The previous crop at this site was always lupins (Table 3.1) except in 2006 when it was canola. A pasture phase of five seasons of lucern and reduced tillage methods were practised at this site previously.

**Table 3.2** General description of soils at the different localities

Locality	A-horizon	Sub-soil horizon	Estimated water holding capacity	Soil identification*
<b>Riversdale</b>	0-20 cm	20-60 cm	Moderate in A-horison	SaLm Gs 2122
	Sandy loam (50% stone)	sandy clay loam/ 70-80% soft shale (lithocutanic B-hor.)	Moderate in B-horizon	non-red B
<b>Swellendam</b>	0-20 cm	20-55 cm	Low - moderate	SaLm Gs 2212
	Sandy loam (40% stone)	sandy clay loam/ 70-80% hard shale (lithocutanic B-hor.)		non-red B
<b>Caledon</b>	0-30 cm	30-60 cm	Low- moderate	SaLm Gs 2211
	Sandy loam (30% stone)	sandy clay loam/ 70-80% hard shale (lithocutanic B-hor.)		non-red B
<b>Moorreesburg</b>	0-35 cm	35-50 cm	Low -moderate	SaLm Gs 2211
	Sandy loam (30% stone)	sandy clay loam/ 70-80% hard shale (lithocutanic B-hor.)		red B
<b>Hopefield</b>	0-50 cm	>50 cm	Low	MeSa Kd 1000
	Sand	E horizon		
	(0% stone)	G – horizon (clay)		

\* Soil Classification Working Group (1991).

### **Caledon**

The western part of the Southern Cape in which the Caledon site is situated, is known to be a production area with high potential due to fairly stable and high rainfall. The soil is classified as a Glenrosa 2211 with a non-red B horizon (Table 3.2). The A-horizon at this site is of sandy loam texture and is 30 cm deep with a stone and gravel fraction of 30% (Table 3.2) and low to moderate water holding capacity. The trial site was situated on the top of a ridge with a very gentle slope. The lithocutanic B-horizon is 60 cm deep and the soil carbon content is high at 2.8% (Table 3.3) with low water holding capacity. As shown in Table 3.3, the pH at this locality is slightly acidic ( $\text{pH}_{(\text{KCl})} = 5.30$ ) with the level of P ( $28 \text{ mg kg}^{-1}$ , Bray 1) within the optimum range (Fertilizer Society of South Africa, 2003).

**Table 3.3** Soil chemical properties in the topsoil (0-15mm) of the A-horizon at the different localities taken in the last season (2006)

Locality	C (%)	pH (KCl)	P (mg/kg)	Ca (mg/kg)	Mg (mg/kg)	Ca : Mg	K (mg/kg)	Na (mg/kg)
Riversdale	1.4	7.20	79 <sup>a</sup>	4040 <sup>a</sup>	183 <sup>a</sup>	13.4	344 <sup>a</sup>	30 <sup>a</sup>
Swellendam	1.4	5.57	55 <sup>a</sup>	900 <sup>a</sup>	256 <sup>a</sup>	2.1	187 <sup>a</sup>	115 <sup>a</sup>
Caledon	2.8	5.30	28 <sup>b</sup>	1250 <sup>c</sup>	200 <sup>c</sup>	3.8	250 <sup>c</sup>	60 <sup>c</sup>
Moorreesburg	1.4	5.33	80 <sup>b</sup>	467 <sup>c</sup>	133 <sup>c</sup>	2.1	196 <sup>c</sup>	20 <sup>c</sup>
Hopefield	0.2	6.88	39 <sup>b</sup>	320 <sup>c</sup>	198 <sup>c</sup>	1.0	191 <sup>c</sup>	49 <sup>c</sup>

Analysis performed: Organic C (Walkley-Black). Extraction methods: pH: KCl, Extractable P, Ca, Mg, K, Na: <sup>a</sup> = Citric acid, <sup>b</sup> = Bray 1, <sup>c</sup> = NH<sub>4</sub>OAc

The level of Ca is relatively high (1250 mg kg<sup>-1</sup>) and the Mg level can be considered optimum (200 mg kg<sup>-1</sup>) with a normal Ca : Mg ratio of 3.8. The level of K (250 mg kg<sup>-1</sup>) is higher than optimum and the Na level is also high at 60 mg kg<sup>-1</sup>. These trials were always established on fields where the previous crop was canola (Table 3.1). Conservation tillage has been practised for at least three seasons at these trial sites.

### **Moorreesburg**

The Moorreesburg site represents a fairly large part of the Swartland production area, with sloped topography and shallow soils containing fairly high stone gravel fractions. Soil at the trial site is fairly similar to the soil at Caledon and the trial site is situated on a gentle slope on top of a hill. The soil is classified as a Glenrosa 2211 with a red B horizon (Table 3.2). The A-horizon is 35 cm deep with sandy loam texture and 30% stone and gravel fraction (Table 3.2) and the water holding capacity is low to moderate. The red lithocutanic B-horizon consists of 70-80% hard shale with low water holding capacity. Soil carbon content (Table 3.3) is similar to the Southern Cape sites (1.4%) and high in comparison with the 0.4% (0-150 mm) measured by Maali (2003) in a conventional production system at the Langgewens Research Station close by. Table 3.3 also indicates that the pH of these soils are slightly acidic (pH<sub>(KCl)</sub> = 5.33), but within the norms for wheat production (Fertilizer Society of South Africa, 2003) with very high levels of P (80 mg kg<sup>-1</sup>, Bray 1). Ca levels (467 mg kg<sup>-1</sup>) and Mg (133 mg kg<sup>-1</sup>) levels are within the optimum range and the Ca : Mg ratio is normal. The level of K (196 mg kg<sup>-1</sup>) is above optimal while the Na level at this site is relatively low at 20 mg kg<sup>-1</sup>. These trials were always planted in the residue of medics which were used as pastures the previous seasons (Table 3.1).

### **Hopefield**

The Hopefield locality represents a production area in the Swartland referred to as the Sandveld, which has a flat topography and differs vastly from the other sites in this study



in soil type. The soil is classified as a Kroonstad (Kd 1000) with an E horizon (Table 3.2). A G horizon is found below the E horizon which consists of clay. The A-horizon is 50 cm deep, very sandy and contains no stone and gravel fractions (Table 3.2). This horizon has low water holding capacity and therefore dries out quickly and is often prone to periodic dry periods and early terminal drought. The G-horizon consists of clay that functions as a barrier layer to prevent water from draining out of the profile. These soils may be easily waterlogged if excess rainfall is received, a situation worsened by the flat topography of the area. This G horizon is however, not permeable to roots and does not contribute much towards the water holding capacity of the soil. Due to the high sand fraction in the A-horizon, the soil carbon content is very low at about 0.2% (Table 3.3). The sandy soils at this site tend to have high pH levels ( $\text{pH}_{(\text{KCl})} = 6.88$ ) with P levels at  $39 \text{ mg kg}^{-1}$  (Bray 1) which is above the optimum range. Ca and Mg levels ( $320$  and  $77 \text{ mg kg}^{-1}$ ) are towards the lower end of the optimum range (Fertilizer Society of South Africa, 2003) with a below normal Ca : Mg ratio of 1. The level of K ( $191 \text{ mg kg}^{-1}$ ) is above optimum, while the Na level at this site is medium-high at  $49 \text{ mg kg}^{-1}$ . Lupins were the previous crop at the two Hopefield sites which were on different farms but on similar soil (Table 3.1).

### **Seasonal rainfall at the trial sites**

The rainfall of each trial site used in this study is given in 10 or 11 day periods (Tables 3.4 and 3.5) and the cumulative rainfall is shown in Figures 3.5 to 3.9. Long-term rainfall data for the two sites for which reliable data could be obtained, Caledon and Moorreesburg, is presented in the accumulative format in Figures 3.7 and 3.8. When the total long-term average pre- and in-season rainfall (January to November) of these two regions are compared, the Swartland is slightly better off with (401 mm) against the 385 mm of the Southern Cape. However, these long-term averages also indicate that the Swartland normally receives less pre-season rainfall than the Southern Cape. This was also the case in this study as indicated by Tables 3.4 and 3.5.

### ***Southern Cape sites***

The Southern Cape sites Riversdale 2004 (216 mm), Swellendam 2004 (127 mm), Caledon 2004 (97 mm) and Caledon 2005 (134 mm) received good rainfall during the pre-plant period (January to March) as indicated by Table 3.4. Such early rainfall is a major advantage as it stimulates weed germination early, which can be controlled effectively by herbicide applications prior to planting. In conservation tillage systems, a large proportion of this pre-season rainfall can be stored, as soil moisture will only be lost through evaporation from the covered surface and not by cultivating the soil.

The flat topography at the Riversdale site does not promote run-off, but can also make these soils prone to water logging in very wet seasons. Rainfall in this region can be very variable with severe droughts in some seasons and very wet (water logging) conditions in others. Riversdale often receives good rainfall in late summer and early autumn which is an advantage as the crop can be established early and therefore has a long growing season. The distribution of rainfall was however very different for these two seasons. Although Riversdale received excellent pre-season rainfall in 2004, the total amount rainfall in the growing season was fairly low (Table 3.4 and Figure 3.5.). The 64 mm received after planting in the middle of May, the 62 mm well spread rain in August and the 60 mm in mid October alleviated dry spells in June and September.

The pre-season rainfall at Riversdale was fairly low (47 mm) in 2006, but an excellent in-season total of 440 mm was received. Rain was well spread over this season with the highest rainfall in August (150 mm) and the lowest in September (24 mm). Due to fairly reliable pre-season and in-season rainfall at this site, long growing seasons in excess of 200 days were realised in both years (Table 3.7).

**Table 3.4** Rainfall for 2004-2006 in 10 or 11 day periods at the trial sites in the Southern Cape

Month	Date	Riversdale		Swellendam			Caledon		
		2004	2006	2004	2005	2006	2004	2005	2006
<b>Jan-Feb</b>		<b>60</b>	<b>34</b>	<b>25</b>	<b>0</b>	<b>15</b>	<b>47</b>	<b>98</b>	<b>41</b>
<b>March</b>		<b>156</b>	<b>13</b>	<b>102</b>	<b>12</b>	<b>6</b>	<b>50</b>	<b>36</b>	<b>12</b>
<b>April</b>	1-10	0	12	5	0	5	17	23	7
	11-20	15	14	30	40	2	17	144	6
	21-30	2	23	0	7	23	4	7	32
	<b>Total</b>	<b>17</b>	<b>49</b>	<b>35</b>	<b>47</b>	<b>30</b>	<b>38</b>	<b>174</b>	<b>45</b>
<b>May</b>	1-10	0	4	0	11	6	10	4	19
	11-20	64	27	25	18	28	2	28	37
	21-31	0	19	13	2	10	4	38	52
	<b>Total</b>	<b>64</b>	<b>51</b>	<b>38</b>	<b>31</b>	<b>44</b>	<b>17</b>	<b>70</b>	<b>107</b>
<b>June</b>	1-10	9	6	11	16	0	14	63	15
	11-20	0	13	0	15	4	21	37	17
	21-30	0	17	7	0	4	6	10	18
	<b>Total</b>	<b>9</b>	<b>35</b>	<b>18</b>	<b>31</b>	<b>8</b>	<b>42</b>	<b>110</b>	<b>50</b>
<b>July</b>	1-10	0	0	0	0	0	5	0	0
	11-20	13	17	2	16	10	1	7	24
	21-31	8	64	6	0	58	38	2	48
	<b>Total</b>	<b>21</b>	<b>81</b>	<b>8</b>	<b>16</b>	<b>67</b>	<b>45</b>	<b>9</b>	<b>72</b>
<b>August</b>	1-10	17	69	9	0	32	0	3	35
	11-20	23	14	28	3	6	0	19	31
	21-31	22	67	11	4	46	2	30	24
	<b>Total</b>	<b>62</b>	<b>150</b>	<b>48</b>	<b>7</b>	<b>84</b>	<b>2</b>	<b>52</b>	<b>90</b>
<b>September</b>	1-10	7	2	4	0	0	9	12	3
	11-20	8	22	0	0	6	16	3	12
	21-30	0	0	3	5	2	4	8	8
	<b>Total</b>	<b>15</b>	<b>24</b>	<b>7</b>	<b>5</b>	<b>8</b>	<b>29</b>	<b>23</b>	<b>22</b>
<b>October</b>	1-10	0	20	0	0	11	87	16	8
	11-20	60	12	-	-	4	30	3	3
	21-31	0	4	-	-	3	6	5	21
	<b>Total</b>	<b>60</b>	<b>36</b>	<b>-</b>	<b>-</b>	<b>18</b>	<b>123</b>	<b>24</b>	<b>31</b>
<b>November</b>	1-10	0	15	-	-	12	-	1	18
	11-20	-	-	-	-	-	-	15	-
	21-30	-	-	-	-	-	-	-	-
	<b>Total</b>	<b>0</b>	<b>15</b>	<b>-</b>	<b>-</b>	<b>12</b>	<b>-</b>	<b>16</b>	<b>18</b>
<b>Pre-season</b>		<b>216</b>	<b>47</b>	<b>127</b>	<b>12</b>	<b>21</b>	<b>97</b>	<b>134</b>	<b>53</b>
<b>In-season</b>		<b>247</b>	<b>440</b>	<b>154</b>	<b>137</b>	<b>271</b>	<b>295</b>	<b>477</b>	<b>435</b>
<b>Grand Total</b>		<b>463</b>	<b>487</b>	<b>281</b>	<b>149</b>	<b>292</b>	<b>392</b>	<b>611</b>	<b>488</b>

The Swellendam site was purposely selected as a research site due to low and erratic rainfall. This erratic nature of the rainfall was experienced during this study with total pre- and in-season rainfall varying between 149 mm (2005) and 292 mm during the study period (Table 3.4). During 2004, the excellent pre-season rain (Table 3.4) was supplemented by sufficient rain in April (35 mm) and May (38 mm), but fairly long dry spells were experienced during June (18 mm) and July (8 mm) which were only alleviated in the second half of August (48 mm). Very little rain was received in September (7 mm) and none in October when the crop was harvested by 13<sup>th</sup> (Table 3.7).

Despite the fact that the 2005 season received well above average rainfall in the Caledon area (Figure 3.7), this season at Swellendam experienced the driest conditions in any of these trials. Very little rain was received in the pre-season (12 mm in March) but 47 mm in April made planting in May possible (Table 3.4). Fairly good rain in May (31 mm) and June (31 mm) allowed the crop to establish, but drought set in soon thereafter with only 16 mm in July, 7 mm in August and 5 mm in September. The crop was harvested on 12 October and the total growth period was only 153 days (Table 3.7).

Good rainfall for the Swellendam area was received in the 2006 season with 21 mm received in the pre-season and 30 mm during April (Table 3.4). It remained wet in May (44 mm), but a dry spell was experienced in June (8 mm). This dry spell was alleviated with good rains in July (67 mm) and August (84 mm) after which little rain was received in September (8 mm) and October (18 mm). With more favourable conditions in this season, the growth period was extended to 186 days (Table 3.7). Although the rainfall was above average for this region the total in-season and pre-season rainfall received (292 mm) is more than 100 mm less than the long-term average received in the Caledon region (Figure 3.7).

As indicated by the long-term average data (Figure 3.7), Caledon site often receives reliable pre-season rainfall and rain is usually received until fairly late in October. However rainfall starts declining at the end of August and the beginning of September, which is about the time when the wheat crop reaches the end of the vegetative stage. After October, until harvesting, very little rain is usually accumulated. Rainfall at Caledon in 2004 was well below the average of this region, but well above the long-term average in both 2005 and 2006.

During the period of this study the total pre- and in-season rainfall varied between 392 and 611 mm. The 2004 season in Caledon started well with good pre-season rainfall (97 mm) and 38 mm during April (Table 3.4). May was fairly dry (17 mm) but good rains

were received in June (42 mm) and July (45 mm). August was exceptionally dry (2 mm), but 29 mm in September and good rain in October (123 mm) brought some relief. The growing period of 179 days was normal for this locality (Table 3.7).

During the 2005 season in Caledon, the second highest in-season total (477 mm) and the highest total rainfall (611 mm) was recorded at this locality (Table 3.4). The season started with excellent pre-season rainfall (134 mm) which continued into April (174 mm). Conditions in May (70 mm) and June (110 mm) remained very favourable, but a dry spell was experienced in July (9 mm) after which conditions remained very favourable for the rest of the season (52 mm in August, 23 mm in September and 24 mm in October). The growing period of 177 days was very similar to the 2004 season (Table 3.7).

Although lower total in-season rainfall was recorded at Caledon in 2006 than in 2005, rainfall during this season was very well distributed (Figure 3.7). The only dry periods of note were the first 10 days in July (0 mm) and the period between 21 September and 20 October which was only moderately dry (19 mm). The growing period was 181 days which was similar to the other two seasons (Table 3.7).

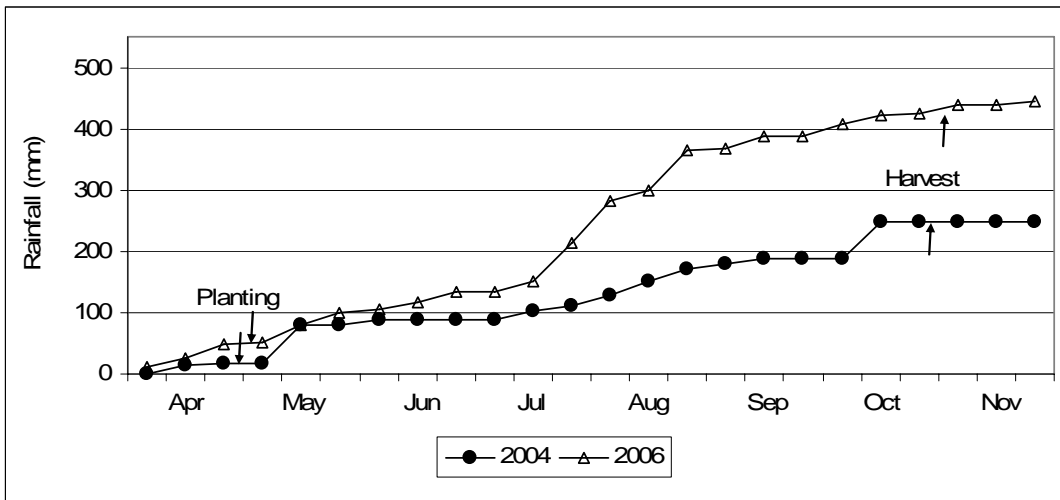

Figure 3.5 Ten day cumulative rainfall (mm) at Riversdale in 2004 and 2006.

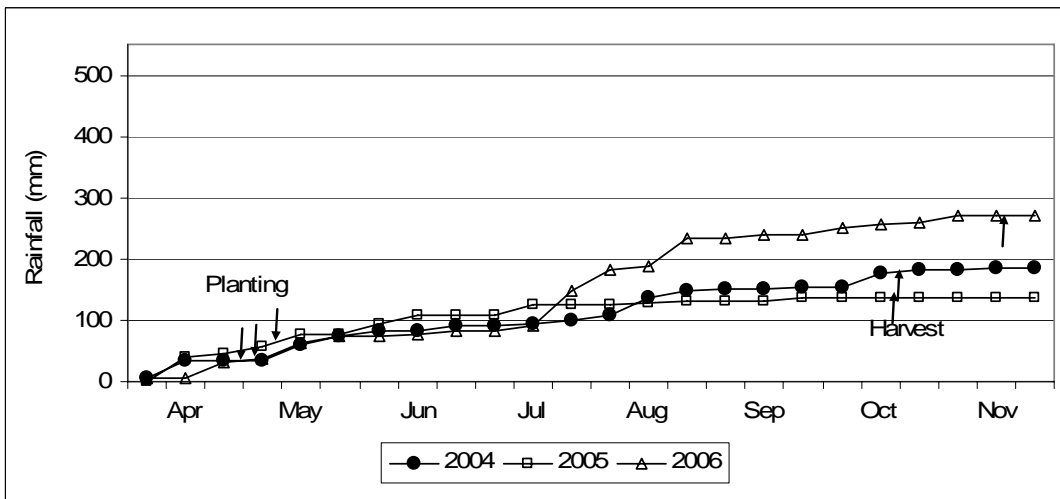

Figure 3.6 Ten day cumulative rainfall (mm) at Swellendam 2004 to 2006.

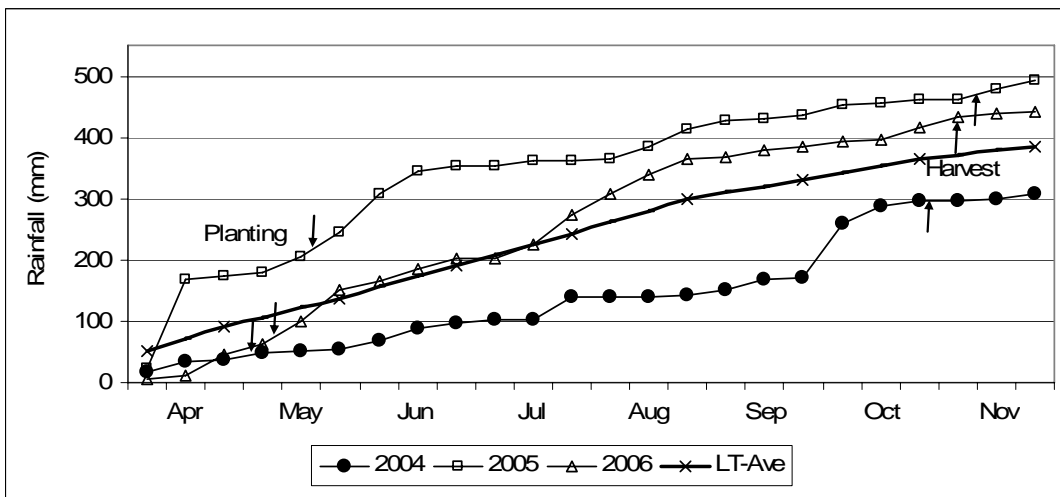

Figure 3.7 Ten day cumulative rainfall (mm) at Caledon (2004-2006) and long-term average (1950-2006).

### **Swartland sites**

In the Swartland, pre-season rainfall (before April) is often low and the rain season usually starts in April (Figure 3.8). The total pre- and in-season rainfall can be fairly high and it varied between 315 and 483 mm during this study (Table 3.4). The Swartland sites were characterised with two consecutive dry seasons in 2004 and 2005 in which rainfall was accumulated below the long-term average (Figure 3.8). Although the 2006 season also started with below average rainfall, excellent rainfall which started late in May and continued through the season, ensured that the 2006 season will be remembered as one of the best production seasons in this region.

During 2004 the pre-season rainfall at Moorreesburg was not sufficient for weeds and the previous crop (medics) to germinate and be chemically controlled (Table 3.1). Fairly good rainfall was received early in April (27 mm) and another 25 mm was received during the rest of the month (Table 3.5), but moisture conditions were considered too marginal for planting in May with only 9 mm received in the latter part of the month. Early in June, 33 mm was received and the crop was established on the 12<sup>th</sup> of June (Table 3.7). Another 63 mm was received soon after planting. Conditions remained favourable for the rest of the season, although September was moderately dry with 23 mm. The crop was harvested on 9 November, which made the growing season very short with only 150 days between planting and harvesting (Table 3.7).

Rainfall received in 2005 followed almost exactly the same pattern as in 2004 (Figure 3.8), but it was decided to plant earlier (25 May), even though soil moisture conditions were marginal. Fortunately good rain in June (83 mm) aided germination and establishment of the crop. Moderate rain was received in July (24 mm) and good rain in August (93 mm). Only moderate rain to sustain the latter growth stages of the crop was received in September (20 mm) and October (11 mm) and the crop was harvested on 9 November, with a normal growing period of 177 days (Table 3.7).

During 2006, the season at Moorreesburg started dry with almost no pre-season rainfall and only 11 mm in April (Table 3.5). Excellent rain was received during May (169 mm) and planting had to be postponed to 24 May due to these very wet conditions (Table 3.7). The rest of the season remained favourable with monthly rainfall in excess of 30 mm until September, with 27 mm in October. The 2006 growing season was somewhat shortened (168 days) due to the late planting date (Table 3.7) but excellent yields were realised in the area. The highest in-season total (478 mm) was recorded at this site (Table 3.5).

**Table 3.5** Rainfall for 2004-2006 in 10 day periods in the Swartland

Month	Date	Moorreesburg			Hopefield		
		2004	2005	2006	2004	2005	2006
<b>Jan-Feb</b>		<b>14</b>	<b>9</b>	<b>3</b>	<b>14</b>	<b>9</b>	<b>1</b>
<b>March</b>		<b>7</b>	<b>4</b>	<b>2</b>	<b>6</b>	<b>0</b>	<b>2</b>
<b>April</b>	1-10	27	0	2	10	2	1
	11-20	15	46	0	10	13	1
	21-30	10	3	23	3	0	9
	<b>Total</b>	<b>51</b>	<b>49</b>	<b>25</b>	<b>22</b>	<b>16</b>	<b>11</b>
<b>May</b>	1-10	0	5	28	0	4	19
	11-20	5	5	107	2	16	62
	21-31	4	5	34	2	7	15
	<b>Total</b>	<b>9</b>	<b>15</b>	<b>169</b>	<b>4</b>	<b>27</b>	<b>96</b>
<b>June</b>	1-10	33	28	5	30	29	2
	11-20	54	40	36	15	27	27
	21-30	9	15	13	9	16	8
	<b>Total</b>	<b>95</b>	<b>83</b>	<b>54</b>	<b>54</b>	<b>71</b>	<b>37</b>
<b>July</b>	1-10	9	0	7	6	0	6
	11-20	0	11	18	0	14	15
	21-31	42	13	28	34	9	26
	<b>Total</b>	<b>51</b>	<b>24</b>	<b>53</b>	<b>40</b>	<b>23</b>	<b>47</b>
<b>August</b>	1-10	34	22	29	35	21	20
	11-20	21	25	49	23	14	31
	21-31	0	47	4	0	26	4
	<b>Total</b>	<b>55</b>	<b>93</b>	<b>81</b>	<b>57</b>	<b>62</b>	<b>55</b>
<b>September</b>	1-10	5	7	0	3	6	0
	11-20	17	1	20	9	1	20
	21-30	1	12	10	0	15	1
	<b>Total</b>	<b>23</b>	<b>20</b>	<b>30</b>	<b>12</b>	<b>22</b>	<b>21</b>
<b>October</b>	1-10	17	5	22	14	1	9
	11-20	3	5	0	4	2	0
	21-31	39	1	5	40	2	5
	<b>Total</b>	<b>59</b>	<b>11</b>	<b>27</b>	<b>58</b>	<b>5</b>	<b>14</b>
<b>November</b>	1-10	0	5	40	0	5	-
	11-20	-	3	-	-	2	-
	21-30	-	-	-	-	-	-
	<b>Total</b>	<b>0</b>	<b>8</b>	<b>40</b>	<b>0</b>	<b>7</b>	<b>-</b>
<b>Pre-season</b>		<b>21</b>	<b>13</b>	<b>5</b>	<b>20</b>	<b>9</b>	<b>3</b>
<b>In-season</b>		<b>342</b>	<b>302</b>	<b>478</b>	<b>245</b>	<b>231</b>	<b>280</b>
<b>Grand Total</b>		<b>363</b>	<b>315</b>	<b>483</b>	<b>265</b>	<b>240</b>	<b>283</b>



The Hopefield locality was chosen as the drier site in the Swartland as it has sandy soils that dry out quickly during dry spells (Table 3.2). Pre-season rainfall at this site was very limited during the study period. In season rainfall usually started declining by September (Table 3.5). The total pre-season and in-season rainfall varied between 240 and 283 mm during this study. Figure 3.9 indicates that rainfall accumulation patterns in this area were virtually the same for the three seasons.

The 2004 season at Hopefield started with fairly low rainfall in the pre-season (20 mm) and low rainfall in April (22 mm) as can be seen in Table 3.5. Planting of the crop was delayed until 9 June (Table 3.7) because very little rain was received in May (4 mm). During the early stages of crop development, sufficient rain was received with 54 mm in June, 40 mm in July and 57 mm in August. A dry spell was experienced in September (12 mm) but good rains were received in October (58 mm). The crop was harvested on the 10<sup>th</sup> of November with a very short growing period of 154 days due to the late planting date (Table 3.7).

The 2005 season at Hopefield started similarly, but 20 mm from the first to the 20<sup>th</sup> of May made planting possible on the 24<sup>th</sup> of May (Table 3.7) after which, another 7 mm was received. June was favourable with 71 mm but only 23 mm was received in July (Table 3.5). Good rainfall was received in August (62 mm), after which it became progressively drier with 22 mm recorded in September, 5 mm in October and 7 mm just before harvesting in November. Due to the earlier planting, the growth period was similar to that at the Moorreesburg site with 177 days between planting and harvesting (Table 3.7).

The 2006 season was also an excellent season for Hopefield, although very little pre-season rainfall was received (3 mm) and the first significant rains were received towards the end of April (9 mm). Good rains were received early in May (19 mm) and it was possible to establish the crop by 16 May (Table 3.7). By the end of May, another 96 mm was received which aided establishment of the crop. Sufficient monthly rainfall was received until 20 August, after which rainfall decreased with very little rain except the 20 mm received in the middle period of September. Only 14 mm rain was received in October and the crop was ready to be harvested on 1 November, 169 days after planting (Table 3.7). Despite the good rainfall season at this locality, the total rainfall received in 2006 (just over 300 mm) is 100 mm lower than the accumulated long-term average rainfall (401 mm) at the Moorreesburg site (Figure 3.8) and equal to the lowest accumulated rainfall at this site (2005).

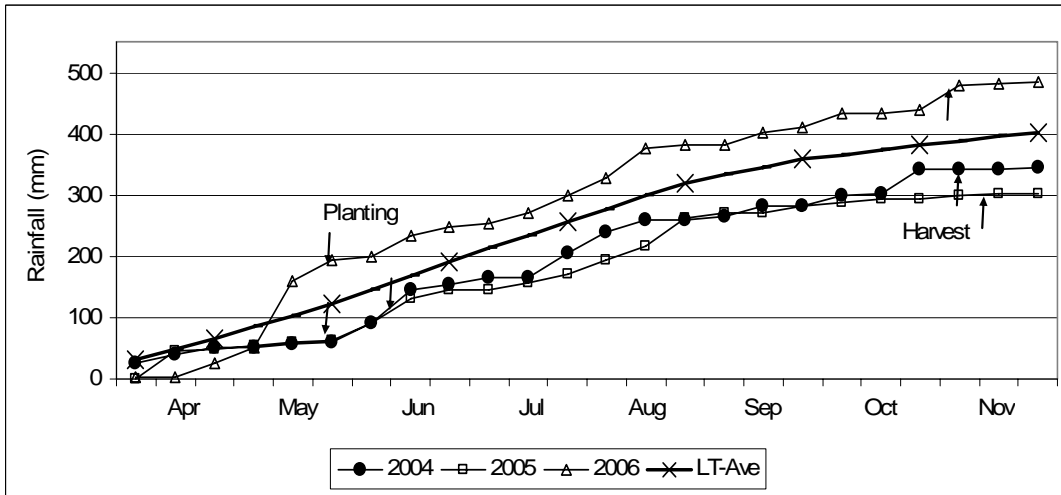

**Figure 3.8** Ten day cumulative rainfall (mm) at Moorreesburg (2004-2006) and long-term average (1973-2006).

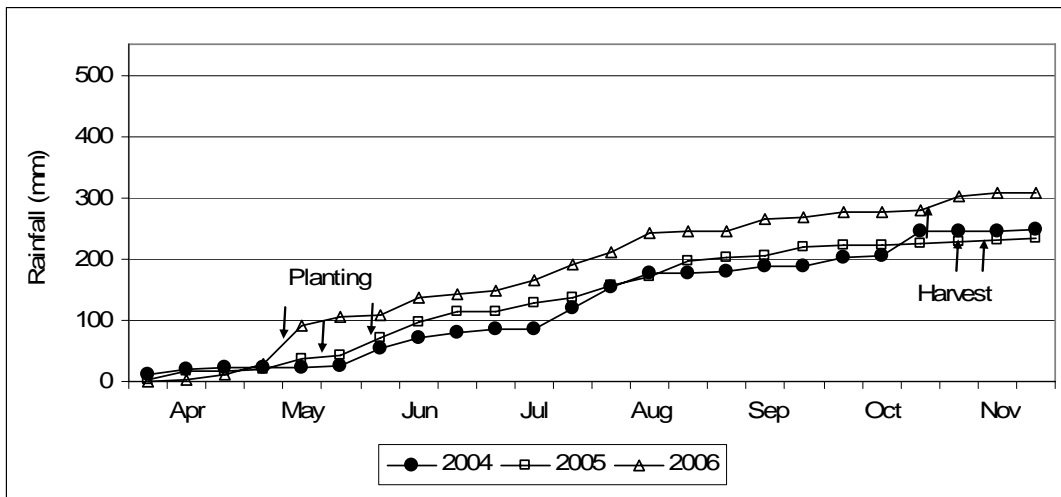

**Figure 3.9** Ten day cumulative rainfall (mm) at Hopefield 2004 to 2006.

### Temperatures during the study period

Ten day average minimum ( $T_{min}$ ) and maximum temperatures ( $T_{max}$ ) and long-term average data (1950-2006) measured at Caledon represent the Southern Cape (Figure 3.10). This figure indicates that average maximum temperatures ( $T_{max}$ ) from April to August were mostly below or similar to the long term average during the study period (2004-2006), but that temperatures from September onwards, were often above the long term average (LT  $T_{max}$ ). Average minimum temperatures ( $T_{min}$ ) were also lower than the long-term average until July, but warmer than long-term average minimum (LT  $T_{min}$ ) temperatures occurred during September in all three seasons. Minimum temperatures in November also tended to be above the long term average.

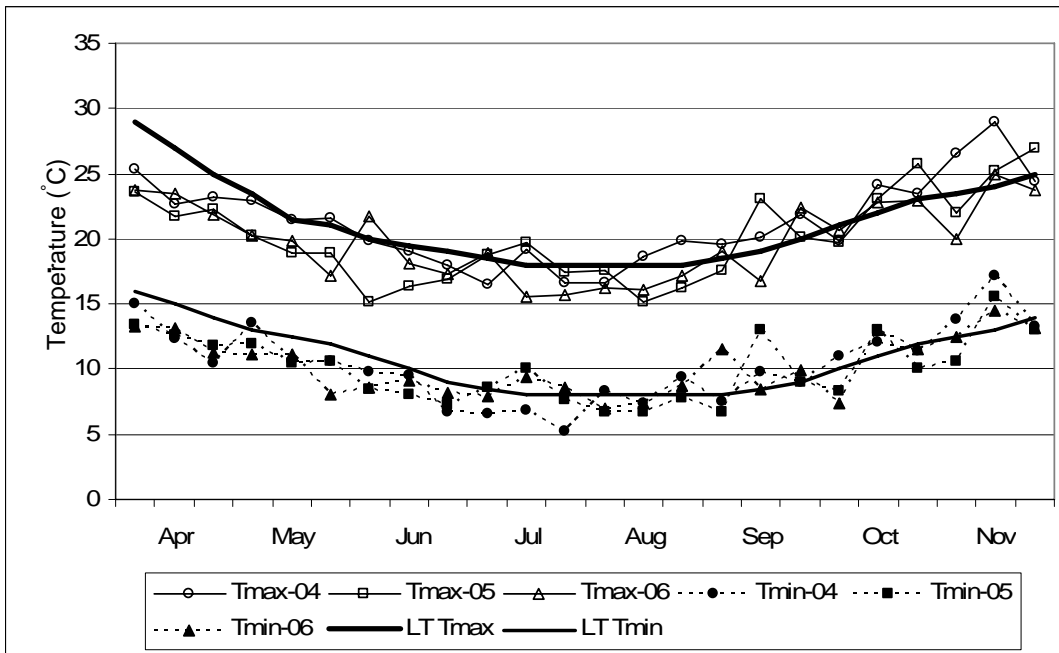
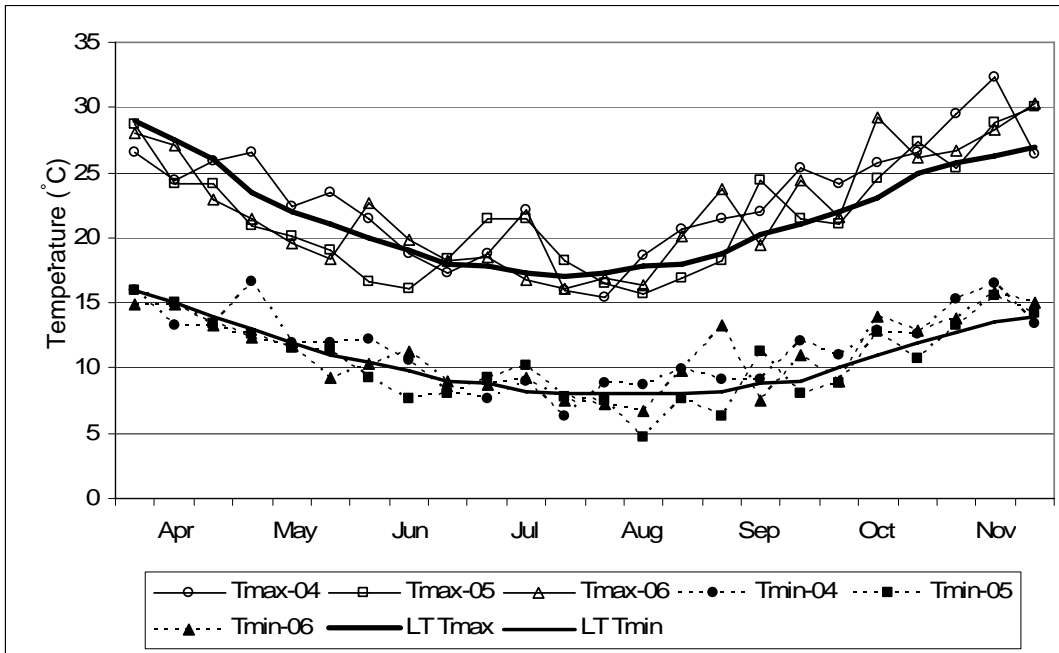

**Figure 3.10** Maximum and minimum temperatures (°C) for 10 day periods (2004-2006) and long-term averages measured at Caledon. Tmax = maximum temperature and Tmin = minimum temperature. -04 indicates the 2004 season. Long-term averages (LT Tmax and LT Tmin) from 1950-2006.

In 2005 a cold, wet period was experienced (Figure 3.7) after planting in May that could have influenced germination of the crop and a fairly warm 10-day period stood out in the middle of September, which coincided with a very dry period at the Swellendam site (Figure 3.6). After this period terminal drought set in and the crop was harvested before mid-October (Table 3.7). In 2006 a warm period stood out in the beginning of June when the 10-day average peaked at 23°C. However water stress during this period would have been unlikely considering the good rainfall in May (Figure 3.7).

Temperatures measured at Moorreesburg represent the Swartland, and are given in Figure 3.11. Maximum temperatures (Tmax) in the Swartland were generally warmer than the long-term average (LT Tmax) in the beginning of the 2004 season (a very dry season), and below the long-term average in 2005 and 2006. In all three seasons average temperatures well above the long-term average occurred from the middle of June to the middle of July. From August onwards, maximum temperatures were also mostly well above the long-term average in all three seasons.

Minimum temperatures (Tmin) were very close to the minimum long-term average at the beginning of the season, except in the first 10 day period of May 2004 when it was well above the minimum long-term average.



**Figure 3.11** Maximum and minimum temperatures (°C) for 10 day periods (2004-2006) and long-term averages measured at Moorreesburg. Tmax = maximum temperature and Tmin = minimum temperature. -04 indicates the 2004 season. Long-term averages (LT Tmax and LT Tmin) from 1976-2006.

Minimum temperatures (Tmin) were very close to the minimum long-term average at the beginning of the season, except in the first 10 day period of May 2004 when it was well above the minimum long-term average. Very high average minimum temperatures stood out in the beginning of September in 2006, when the average minimum for the 10-day period was 13°C. As was the case with the higher than average maximum temperatures, the average minimum temperatures in all three seasons were also mostly above the long-term average from the beginning of September onwards.

### Description of cultivars

Four hard red spring wheat cultivars were used and were chosen because of their differences in growth characteristics (growth period, tillering capacity and disease resistance) in all experiments in this study. All seed lots used were commercial, certified and treated seed obtained from agents of the seed company. A summary of characteristics of cultivars is given in Table 3.6 (ARC-Small Grain Institute, 2007).

The cultivar SST 57 was the first cultivar that was released in this group (Table 3.6). It has a medium growing period (96-105 days from emergence to anthesis) and therefore has limited tillering ability. This cultivar has the solid stem trait, which gives it excellent straw strength and standing ability. It is known to produce excellent hectolitre mass (test weight). It is also the most resistant cultivar to leaf and stripe rust in this group, but is moderately susceptible to stem rust.

**Table 3.6** Summary of characteristics of cultivars included in this study

Cultivar	DOR	Growth period	DTA	HLM	SS	Leaf rust	Stem Rust	Stripe rust
<b>SST 57</b>	1995	Medium	96 - 105	Excellent	Excellent	R	MS	R
<b>SST 88</b>	1998	Long	108 – 112	Good	Good	S	S	R
<b>SST 94</b>	1999	Medium-short	90 - 98	Good	Good	MR	R	MR
<b>SST 015</b>	2001	Medium	94 - 103	Good	Good	MS	MS	MR

**DOR:** Date of release  
**DTA:** Days to anthesis (from emergence)  
**HLM:** Hectolitre mass  
**SS:** Straw strength

R= Resistant  
 S = Susceptible  
 MR = Medium resistant  
 MS = Medium susceptible

SST 88 which was released in 1998 (Table 3.6), is still a very popular cultivar in the Western Cape wheat production region. Due to its long growing period (108-112 days from emergence to anthesis) it has excellent tillering abilities if planted early in the season. The cultivar normally produces good hectolitre mass and has good straw strength. Unfortunately, this cultivar is susceptible to both leaf and stem rust and often requires additional fungicide applications to protect the crop against the diseases. It does have resistance against stripe rust.

SST 94 was released one year after SST 88 (Table 3.6) and had the shortest growing period of cultivars in this group (90-98 days from emergence to anthesis). Due to the short growing season it is a suitable cultivar if planted late, but it has limited tillering ability. Hectolitre mass and standing ability of this cultivar are good and it is moderately resistant to leaf and stripe rust and is resistant to stem rust. This cultivar is not as popular as some of the others and was, unfortunately for this study, withdrawn as a commercial cultivar after the 2005 season.

SST 015 was the last of the cultivars to be released (2001) and replaced SST 94 in this study (Table 3.6). The growing period of this cultivar is very similar to that of SST 57 (medium) and the number of days between emergence and anthesis ranges from 94 – 103. Hectolitre and standing ability of this cultivar is considered to be good. This cultivar is moderately susceptible to leaf and stem rust and is moderately resistant to stripe rust.

### Description of experimental procedure

The same experimental procedure was used for all the cultivar x row width x planting density trials at all localities and seasons described in this study, but treatments (cultivars, row widths and planting densities), differed among localities and seasons. These trials were planted at all localities shown in Figure 3.4 and described in Tables

3.1, 3.2 and 3.3 from 2004 to 2006, with the exception of the trial at Riversdale in 2005 which was planted, but no data was collected because post-emergence plant counts revealed that planting densities were not correctly applied by the planter.

In these factorial (cultivar x row width x planting density) experiments, different cultivars were planted in different row widths and at different planting densities. Randomised complete block designs with split-split plot arrangements were used with cultivars as the whole plots, split into row widths and row widths split into planting density treatments. Three replications were used at each location.

Plots contained 10 or 14 rows when planted, depending on the row width. The plot sizes were 10 m x 3.5 m (250 mm and 350mm row widths) or 10 m x 4.2 m (300 mm row width). The size of the yield plots was 1.5 x 7m for 250 mm and 300 mm row width and 1.4 x 7 m for the 350 mm row width. The two outer rows of each plot were regarded as guard rows and were not sampled. In the Southern Cape only two row widths (250 mm and 300mm) were used while in the Swartland three row widths (250 mm, 300 mm and 350 mm) were used.

Planting of the trials commenced after sufficient rain was received to allow weeds to germinate and be chemically controlled with glyphosate applications. Planting of trials always coincided with producers planting in that area. In the Southern Cape region, planting started in the beginning of May and was completed by middle May while in the Swartland planting took place from middle May to the last week in May, which was within the recommended planting dates for the cultivars (Table 3.7) except for Moorreesburg and Hopefield in 2004 when planting in the region was delayed due to unfavourable moisture conditions.

**Table 3.7** Planting dates, harvesting dates and the growing period (number of days between planting and harvesting) at each locality in the Western Cape 2004-2006

Locality	Planting date			Harvesting date			Growing period (days)		
	2004	2005	2006	2004	2005	2006	2004	2005	2006
<b>Riversdale</b>	03/05	-	05/05	02/11	-	13/11	213	-	222
<b>Swellendam</b>	04/05	12/05	09/05	13/10	12/10	11/11	162	153	186
<b>Caledon</b>	08/05	21/05	13/05	03/11	14/11	10/11	179	177	181
<b>Moorreesburg</b>	12/06	25/05	24/05	09/11	18/11	08/11	150	177	168
<b>Hopefield</b>	09/06	24/05	16/05	10/11	17/11	01/11	154	177	169

(-) Data of the trial is not presented.

Harvesting commenced after the crop was harvest ready (12-13% moisture), but did not always coincide with the exact date of harvest readiness due to availability of the plot harvester (Table 3.7).

In 2004 and 2005 the cultivars SST 57, SST 88 and SST 94 were used in the Southern Cape and SST 88 and SST 94 in the Swartland. In 2006, SST 94 was replaced with SST 015 in both regions because SST 94 was withdrawn from commercial production. Planting densities used, differed among each locality, in order to find a suitable range to be tested for each production area, but remained the same within each locality over seasons, except Hopefield 2004 which differed from 2005 and 2006. The planting density (in kg seed ha<sup>-1</sup>) was calculated using target (no.) plants m<sup>-2</sup>, Thousand Kernel Mass (TKM) in gram (g) and estimated seedling survival rate (%) according to the following formula (ARC-Small Grain Institute, 2007):

$$\text{Planting density (kg seed ha}^{-1}\text{)} = \frac{\text{Target (no.) plants m}^{-2} \times \text{TKM (g)}}{\text{Estimated seedling survival rate (\%)}}$$

An estimated seedling survival rate of 80% was used when calculating planting densities (kg seed ha<sup>-1</sup>). Estimated seedling survival rate (%) caters for both the germination percentage of the seed and the possible loss of seedlings after planting. This means that 25% more seed was placed than the target (no.) plants m<sup>-2</sup> treatment required. The Thousand Kernel Mass (TKM) for each seed lot used is given in Table 3.8. The cultivars used, target (no.) of plants m<sup>-2</sup> and planting densities (kg seed ha<sup>-1</sup>) for each locality are given in Table 3.9.

**Table 3.8** Thousand Kernel Mass (g) for the cultivars used

Year	SST 57	SST 88	SST 94	SST 015
2004	38	40	38	-
2005	34	48	40	-
2006	38	43	-	48

**Table 3.9** Cultivars, target (no.) of plants m<sup>-2</sup> and planting densities (kg seed ha<sup>-1</sup>) used as treatments at the different localities 2004-2006

Year	Cultivar											
	SST 57			SST 88			SST 94			SST 015		
	Target (no.) plants m <sup>-2</sup>											
	Riversdale											
	<b>100</b>	<b>150</b>	<b>200</b>	<b>100</b>	<b>150</b>	<b>200</b>	<b>100</b>	<b>150</b>	<b>200</b>	<b>100</b>	<b>150</b>	<b>200</b>
<b>2004</b>	-	-	-	50	75	100	48	71	95	-	-	-
<b>2006</b>	48	71	95	54	81	108	-	-	-	60	90	120
	Swellendam											
	<b>150</b>	<b>200</b>	<b>250</b>	<b>150</b>	<b>200</b>	<b>250</b>	<b>150</b>	<b>200</b>	<b>250</b>	<b>150</b>	<b>200</b>	<b>250</b>
<b>2004</b>	71	95	119	75	100	125	71	95	119	-	-	-
<b>2005</b>	-	-	-	90	120	150	75	100	125	-	-	-
<b>2006</b>	71	95	119	81	107	134	-	-	-	90	120	150
	Caledon											
	<b>100</b>	<b>175</b>	<b>250</b>	<b>100</b>	<b>175</b>	<b>250</b>	<b>100</b>	<b>175</b>	<b>250</b>	<b>100</b>	<b>175</b>	<b>250</b>
<b>2004</b>	48	83	119	50	88	126	48	83	119	-	-	-
<b>2005</b>	43	75	106	60	105	150	50	88	125	-	-	-
<b>2006</b>	48	83	119	54	94	134	-	-	-	60	105	150
	Moorreesburg											
	<b>100</b>	<b>175</b>	<b>250</b>	<b>100</b>	<b>175</b>	<b>250</b>	<b>100</b>	<b>175</b>	<b>250</b>	<b>100</b>	<b>175</b>	<b>250</b>
<b>2004</b>	-	-	-	50	88	126	48	83	119	-	-	-
<b>2005</b>	-	-	-	60	105	150	50	88	125	-	-	-
<b>2006</b>	-	-	-	54	94	134	-	-	-	60	105	150
	Hopfield											
	<b>150</b>	<b>200</b>	<b>250</b>	<b>150</b>	<b>200</b>	<b>250</b>	<b>150</b>	<b>200</b>	<b>250</b>	<b>100</b>	<b>175</b>	<b>250</b>
<b>2004</b>	-	-	-	75	100	125	72	95	119	-	-	-
	<b>100</b>	<b>175</b>	<b>250</b>	<b>100</b>	<b>175</b>	<b>250</b>	<b>100</b>	<b>175</b>	<b>250</b>	<b>100</b>	<b>175</b>	<b>250</b>
<b>2005</b>	-	-	-	60	105	150	50	88	125	-	-	-
<b>2006</b>	-	-	-	54	94	134	-	-	-	60	105	150

Target (no.) of plants m<sup>-2</sup> are depicted in bold. 80% seedling survival rate was used throughout.



All trials were fertilised with urea (46% N) as the primary source of nitrogen and mono ammonium phosphate (MAP (33%), 11% N and 22% P) as primary source of phosphate. At all localities and in all seasons, MAP was applied at a rate of 68 kg ha<sup>-1</sup> supplying 15 kg P ha<sup>-1</sup> and 7.5 kg N ha<sup>-1</sup>. The remaining nitrogen to supply a total of 20 kg N ha<sup>-1</sup> in Riversdale (29 kg urea ha<sup>-1</sup>), 30 kg N ha<sup>-1</sup> at Swellendam (50 kg urea ha<sup>-1</sup>) and 40 kg N ha<sup>-1</sup> at Caledon, Moorreesburg and Hopefield (73 kg urea ha<sup>-1</sup>) was provided by urea. Of the total amount of fertiliser, 25% was placed with the seed and 75% was band-placed below the seed. Top dressing of nitrogen was done by the respective farmers at Caledon (40 kg N ha<sup>-1</sup>), Moorreesburg (40 kg N ha<sup>-1</sup> in 2005 and 60 kg N ha<sup>-1</sup> in 2006) and Hopefield (25 kg N ha<sup>-1</sup>), similar to application in their fields but no top dressing was applied at the Riversdale and Swellendam sites.

During all seasons, the pre-emergence herbicide trifluralin (Crew®) was applied during the planting process to help control herbicide resistant ryegrass. In-season application of herbicides, fungicides and insecticides was applied according to the program and management practises of the farmer.

Seedling numbers were counted three to four weeks after planting at every locality in 2005 and 2006. Three random samples each of 0.5 m length, were taken in three different rows per plot. The sample area was calculated as 1.5 multiplied by the row width used in that treatment. Seedling number m<sup>-2</sup> was then used to calculate seedling survival percentage for each plot:

$$\text{Seedling survival (\%)} = \frac{\text{Seedling number } m^{-2}}{\text{*number of seeds placed } m^{-2}} \times 100$$

$$\text{*The number of seeds placed } m^{-2} = \frac{\text{kg seed } ha^{-1}}{TKM} \times 100$$

alternatively,

$$\text{* The number of seeds placed } m^{-2} = \text{target (no.) of plants } m^{-2} \text{ plus 25\%}$$

The number of heads m<sup>-2</sup> determined at the end of the 2005 and 2006 seasons. In 2005, heads were counted by taking random samples (0.5 m in length) from three different rows in each plot. Whole plants were removed and bagged and heads were counted on the samples at a later stage. In 2006 counting was done *in situ* by counting the heads in three randomly selected rows (0.5 m length) in each plot just before harvesting.

Yield plots were harvested from each plot with a Wintersteiger plot harvester. After harvesting, samples were cleaned, removing all chaff that remained in the sample. The samples were weighed to determine the plot weight, from which grain yield (ton ha<sup>-1</sup>) was calculated.

After weighing, samples were collected to determine the grain quality parameters, grain protein (%), hectolitre mass (kg hl<sup>-1</sup>) and kernel weight (TKM). Grain protein was determined at the Grain Quality Laboratory at ARC-Small Grain Institute, Bethlehem using the Near-Infrared Reflectance method for protein determination in wheat flour AACC Method 39-11 (American Association of Cereal Chemists, 2000a). Hectolitre mass (Test weight) given in kg hl<sup>-1</sup>, was determined according to AACC Method 55-10 (American Association of Cereal Chemists, 2000b).

Thousand Kernel Mass (TKM) was determined for each sample by counting five hundred kernels with a Numigral seed counter and multiplying the weight (g) by two. Seedling numbers m<sup>-2</sup>, the number of heads m<sup>-2</sup>, grain yield (g m<sup>-2</sup>) and TKM was used to calculate the number of heads plant<sup>-1</sup> and the number kernels head<sup>-1</sup> as follows:

$$\text{The number of heads plant}^{-1} = \frac{\text{heads m}^{-2}}{\text{seedling numbers m}^{-2}}$$

The number of kernels head<sup>-1</sup> were calculated from the yield head<sup>-1</sup> (g) divided by the average weight of a single kernel (TKM (g) /1000) as follows:

$$\text{Yield head}^{-1} \text{ (g)} = \frac{\text{grain yield g m}^{-2}}{\text{number of heads m}^{-2}}$$

$$\text{Number of kernels head}^{-1} = \frac{\text{Yield head}^{-2} \text{ (g)}}{(\text{TKM (g)}/1000)}$$

### **Soil analysis**

The topsoil (0-150mm) was sampled for analysis at Caledon, Moorreesburg and Hopefield the 2006 season. Three samples of every replicate in each trial were taken and combined for analysis. The average value of these replicates is presented in Table 3.3. For the Riversdale and Swellendam localities, soil analysis results from soil samples taken in close proximity to the trial sites, provided by the Western Cape Department of Agriculture is presented.

Soil samples were analysed using standard procedures (The Non-affiliated Soil Analysis Work Committee, 1990). Analysis was performed at two different soil laboratories namely at the soil testing laboratory, Institute for Plant Production, Elsenburg (Department of Agriculture, Western Cape) and the ARC-Small Grain Institute Soil Laboratory (Bethlehem). Both laboratories used the Walkley-Black method to determine organic C and KCl extraction for pH analysis. Extractable P and the exchangeable base elements Ca, Mg, K and Na were analysed with citric acid extraction by the Elsenburg laboratory (Riversdale and Swellendam). The Bray 1 extraction method for P was used by the ARC-SGI laboratory (Caledon, Moorreesburg, Hopefield) and  $\text{NH}_4\text{OAc}$  for exchangeable K, Ca, Mg and Na.

### **Statistical analysis and presentation of data**

Data of all trials were analysed using the statistical software Genstat for Windows 10<sup>th</sup> Edition (Payne *et al*, 2006). Analysis of variance (ANOVA) was performed for each parameter at each locality and season. The Coefficient of variance (Cv (%)) and least significant difference ( $\text{LSD}_{(0.05)}$ ) values were calculated by Genstat at the  $p < 0.05$  confidence level. ANOVA tables and treatment means of each dataset are presented in appendixes on the attached CD, indicated by a unique reference number which is referred to in the text. Only treatment means containing significant differences and significant interactions ( $p < 0.05$ ) are shown and discussed in the text. The same software were used for regression analysis.

## CHAPTER 4

### THE INFLUENCE OF ROW WIDTH AND PLANTING DENSITY ON WHEAT IN CONSERVATION TILLAGE SYSTEMS IN THE WESTERN CAPE. PART 1: PLANT ESTABLISHMENT AND SEEDLING SURVIVAL

#### Introduction

The adoption of conservation tillage requires a major change in the way cereal crops are established in the Western Cape. In order to establish the crop successfully in retained crop residue, row widths wider than those conventionally used (175 - 180 mm) have to be considered. A row width of 250 mm is considered to be the minimum that can be used for planting in low residue levels, but for high residue levels, row widths up to 300 mm have to be used (Guimelli *et al.*, 2002). Effective and early seedling establishment is important in Mediterranean environments due to the uncertainty of rainfall later in the season which can influence plant development and the possibility of early terminal drought which can end the season prematurely. In this chapter, the effect of wide row widths (250 – 350 mm) and the effect of different planting densities on seedling survival will be investigated for different cultivars and localities.

#### Experimental procedure

The experimental procedure, description of trial sites, data collecting and climatic data are discussed in Chapter 3. The localities included, treatments applied and data collected (seedling numbers counted on 3 x 0.5 m row lengths per plot and % seedling survival), is summarised in Table 4.1. Analyses of Variance and tables of means of all data pertaining to this chapter, are shown in Appendix A on the attached CD. Non-significant differences and significance levels ( $P > F$ ) for differences between treatment means and interactions are summarised in this chapter, but only significant treatment means and significant interactions ( $p < 0.05$ ) will be discussed.

**Table 4.1** Summary of localities, years, treatments and data collected

Locality	Treatments	Data collected
<b>Southern Cape</b>		
<b>Riversdale</b>	<p><b>Cultivars:</b> 2006 – SST 88, SST 57, SST 015</p> <p><b>Row widths:</b> 250 and 300 mm</p> <p><b>Planting densities:</b> 100, 150 and 200 target (no.) of plants m<sup>-2</sup>.</p>	<p>Seedling numbers m<sup>-2</sup></p> <p>Seedling survival (%)</p>
<b>Swellendam</b>	<p><b>Cultivars:</b> 2005 – SST 88, SST 94 2006 – SST 88, SST 57, SST 015</p> <p><b>Row widths:</b> 250 and 300 mm</p> <p><b>Planting densities:</b> 150, 200 and 250 target (no.) of plants m<sup>-2</sup>.</p>	<p>Seedling numbers m<sup>-2</sup></p> <p>Seedling survival (%)</p>
<b>Caledon</b>	<p><b>Cultivars:</b> 2005 – SST 88, SST 57, SST 94 2006 – SST 88, SST 57, SST 015</p> <p><b>Row widths:</b> 250 and 300 mm</p> <p><b>Planting densities:</b> 100, 175 and 250 target (no.) of plants m<sup>-2</sup>.</p>	<p>Seedling numbers m<sup>-2</sup></p> <p>Seedling survival (%)</p>
<b>Swartland</b>		
<b>Moorreesburg</b>	<p><b>Cultivars:</b> 2005 – SST 88, SST 94 2006 – SST 88, SST 015</p> <p><b>Row widths:</b> 250, 300 and 350 mm</p> <p><b>Planting densities:</b> 100, 175 and 250 target (no.) of plants m<sup>-2</sup>.</p>	<p>Seedling numbers m<sup>-2</sup></p> <p>Seedling survival (%)</p>
<b>Hopefield</b>	<p><b>Cultivars:</b> 2005 – SST 88, SST 94 2006 – SST 88, SST 015</p> <p><b>Row widths:</b> 250, 300 and 350 mm</p> <p><b>Planting densities:</b> 100, 175 and 250 target (no.) of plants m<sup>-2</sup>.</p>	<p>Seedling numbers m<sup>-2</sup></p> <p>Seedling survival (%)</p>

## Results

Significance levels ( $Pr > F$ ) for differences between treatment means with regard to seedling numbers m<sup>-2</sup> counted at 30-40 days after planting and seedling survival (%) as a result of the treatments applied are given in Table 4.2.

**Table 4.2** Pr >F values and coefficients of variance of the main effects and interactions for seedlings m<sup>-2</sup> and seedling survival (%) 2005-2006

	2005		2006	
	Seedlings m <sup>-2</sup>	Seedling survival (%)	Seedlings m <sup>-2</sup>	Seedling survival (%)
<b>Riversdale</b>				
Cultivar	-	-	ns	ns
Row width	-	-	0.029	0.021
RW x CV	-	-	ns	ns
Planting Density	-	-	<0.001	0.001
PD x CV	-	-	ns	ns
PD x RW	-	-	ns	ns
PD x RW x CV	-	-	ns	ns
Cv (%)	-	-	<b>10.7</b>	<b>9.3</b>
Appendix no.	-	-	<b>A-9</b>	<b>A-14</b>
<b>Swellendam</b>				
Cultivar	ns	ns	ns	ns
Row width	0.033	0.045	ns	ns
RW x CV	ns	ns	ns	ns
Planting Density	<0.001	ns	<0.001	ns
PD x CV	ns	ns	ns	ns
PD x RW	ns	ns	ns	ns
PD x RW x CV	ns	ns	ns	ns
Cv (%)	<b>12.3</b>	<b>12.6</b>	<b>12.9</b>	<b>12.0</b>
Appendix no.	<b>A-1</b>	<b>A-5</b>	<b>A-10</b>	<b>A-15</b>
<b>Caledon</b>				
Cultivar	ns	ns	ns	ns
Row width	ns	ns	<0.001	<0.001
RW x CV	ns	ns	ns	ns
Planting Density	<0.001	0.006	<0.001	ns
PD x CV	ns	ns	ns	ns
PD x RW	ns	ns	<0.001	0.013
PD x RW x CV	ns	ns	ns	ns
Cv (%)	<b>13.2</b>	<b>13.1</b>	<b>8.3</b>	<b>7.8</b>
Appendix no.	<b>A-2</b>	<b>A-6</b>	<b>A-11</b>	<b>A-16</b>

**Table 4.2 (continued)** Significance levels ( $P > F$ ) and coefficients of variance of the main effects and interactions for seedlings  $m^{-2}$  and seedling survival (%) 2005-2006

	2005		2006	
	Seedlings $m^{-2}$	Seedling survival (%)	Seedlings $m^{-2}$	Seedling survival (%)
<b>Moorreesburg</b>				
Cultivar	ns	ns	ns	ns
Row width	ns	ns	0.02	ns
RW x CV	ns	ns	ns	ns
Planting Density	<0.001	0.006	<0.001	<0.001
PD x CV	ns	ns	ns	ns
PD x RW	ns	ns	0.001	0.015
PD x RW x CV	ns	ns	ns	ns
Cv (%)	<b>11.2</b>	<b>8.6</b>	<b>4.0</b>	<b>3.8</b>
Appendix no.	<b>A-3</b>	<b>A-7</b>	<b>A-12</b>	<b>A-17</b>
<b>Hopefield</b>				
Cultivar	ns	ns	0.040	0.021
Row width	ns	ns	ns	ns
RW x CV	ns	ns	ns	ns
Planting Density	<0.001	ns	<0.001	ns
PD x CV	ns	ns	0.009	ns
PD x RW	ns	ns	ns	ns
PD x RW x CV	ns	ns	ns	ns
Cv (%)	<b>10.3</b>	<b>10.8</b>	<b>13.3</b>	<b>10.8</b>
Appendix no.	<b>A-4</b>	<b>A-8</b>	<b>A-13</b>	<b>A-18</b>

CV=Cultivar, RW=row width, PD=planting density and Cv (%) = the coefficient of variance

### **Seedlings $m^{-2}$**

*No significant differences in the number of seedlings  $m^{-2}$  due to cultivars, were found at any of the localities (Table 4.2) in 2005. In 2006, a significant interaction between planting density and cultivars (PD x CV) was found at Hopefield. The number of seedlings  $m^{-2}$  was significantly affected by row width at Swellendam in 2005 and at Riversdale in 2006. Significant planting density x row width (PD x RW) interactions were found at Caledon and at Moorreesburg in 2006. Planting density treatments resulted in significant differences in seedlings  $m^{-2}$  at all localities.*

The significant planting density x cultivar interaction (PD x CV) found at Hopefield in 2006 was the result of significantly fewer seedlings of the cultivar SST 015 that survived at the highest seeding density of 250 target (no.) plants  $m^{-2}$  when compared to SST 88 (Table 4.3).

**Table 4.3** The cultivar planting density interaction for seedling number m<sup>-2</sup> and treatment means for seedling survival (%) at Hopefield 2006

Cultivar	Seedling number m <sup>-2</sup>				Seedling survival (%)			
	Planting density target (no.) of plants m <sup>-2</sup>				Planting density target (no.) of plants m <sup>-2</sup>			
	100	175	250	Mean	100	175	250	Mean
<b>SST 88</b>	118a	199a	289b	<b>202b</b>	93.2	91.2	92.8	<b>92.6a</b>
<b>SST 015</b>	110a	185a	229a	<b>174a</b>	87.2	84.8	73.4	<b>81.8b</b>
<b>Mean</b>	<b>113a</b>	<b>192b</b>	<b>260b</b>	<b>188.3</b>	<b>90.5</b>	<b>87.9</b>	<b>83.1</b>	<b>87.2</b>
LSD <sub>(0.05)</sub> Cultivars = 24.3					LSD <sub>(0.05)</sub> Cultivars = 6.77			
LSD <sub>(0.05)</sub> Planting densities = 17.24					LSD <sub>(0.05)</sub> Planting densities = ns			
LSD <sub>(0.05)</sub> CV x PD interaction = 23.49					LSD <sub>(0.05)</sub> CV x PD interaction = ns			

Means within the interaction followed by the same letter do not differ significantly. Means within a row (planting density) and within a column (cultivar) indicated in bold, do not differ significantly if followed by the same letter.

The reason for this unclear, as the same response were not found at other localities where the same source of SST 015 seed were used. One possible explanation might be that SST 015 was less able to cope with competition at high planting densities at this locality with sandy soils that dry out quickly. These soils have very low stone and gravel fractions (Table 3.2), which can be beneficial to seedling emergence while wet, but the A-horizon has low water storage capacity, which increases the risk of water stress during early plant development. However with 77 mm received between planting and counting of the seedlings (Table 3.5) the possibility of severe water stress at this early growth stage would have been unlikely.

At Swellendam, where the seedling number was affected by row width in 2005, a mean value of 164 seedlings m<sup>-2</sup> was found with the 250 mm row width compared to 151.2 seedlings m<sup>-2</sup> with the 300 mm row width (Table 4.4).

**Table 4.4** Treatment means for number of seedlings m<sup>-2</sup> at Swellendam 2005

Row width (mm)	Planting density (Target (no.) plants m <sup>-2</sup> )			
	150	200	250	Mean
<b>250</b>	124	176	192	<b>164a</b>
<b>300</b>	114	150	189	<b>151b</b>
<b>Mean</b>	<b>119a</b>	<b>163b</b>	<b>191b</b>	<b>158</b>

LSD<sub>(0.05)</sub> Row width = 11.45

LSD<sub>(0.05)</sub> Planting densities = 42.6

LSD<sub>(0.05)</sub> RW x PD = ns

Means within the interaction followed by the same letter do not differ significantly. Means within a row (planting density) and within a column (row width) indicated in bold, do not differ significantly if followed by the same letter.

Row width significantly influenced seedling establishment at Riversdale in 2006 when seedling numbers m<sup>-2</sup> were reduced from 164 seedlings m<sup>-2</sup> at the 250 mm row width to 151 seedlings m<sup>-2</sup> with the 300 mm row width (Table 4.5), but seedling numbers m<sup>-2</sup> were not significantly ( $p > 0.05$ ) affected by row width at Swellendam.



**Table 4.5** Treatment means (main effects) of row widths and planting density at Riversdale and Swellendam in 2006

Row width	Seedling number m <sup>-2</sup>				Seedling survival (%)			
	Planting density				Planting density			
	Target (no.) plants m <sup>-2</sup>				Target (no.) plants m <sup>-2</sup>			
<b>Riversdale</b>								
	<b>100</b>	<b>150</b>	<b>200</b>	<b>Mean</b>	<b>100</b>	<b>150</b>	<b>200</b>	<b>Mean</b>
<b>250</b>	119	167	206	<b>164a</b>	94.3	89.9	82.1	<b>88.8a</b>
<b>300</b>	107	156	190	<b>151b</b>	85.3	82.9	75.9	<b>81.4b</b>
<b>Mean</b>	<b>113a</b>	<b>162b</b>	<b>198c</b>	<b>158</b>	<b>89.8a</b>	<b>86.4a</b>	<b>79.0b</b>	<b>85.1</b>
<b>Swellendam</b>								
	<b>150</b>	<b>200</b>	<b>250</b>	<b>Mean</b>	<b>150</b>	<b>200</b>	<b>250</b>	<b>Mean</b>
<b>250</b>	168	210	268	<b>216</b>	89.7	84.2	85.8	<b>86.6</b>
<b>300</b>	152	211	247	<b>203</b>	80.8	84.5	79.3	<b>81.5</b>
<b>Mean</b>	<b>160a</b>	<b>211b</b>	<b>258c</b>	<b>209</b>	<b>85.3</b>	<b>84.3</b>	<b>82.5</b>	<b>84.0</b>

LSD<sub>(0.05)</sub> Row width = 11.35  
LSD<sub>(0.05)</sub> Planting densities = 11.63  
LSD<sub>(0.05)</sub> RW x PD = ns

LSD<sub>(0.05)</sub> Row width = ns  
LSD<sub>(0.05)</sub> Planting densities = 18.58  
LSD<sub>(0.05)</sub> RW x PD = ns

**Riversdale**

LSD<sub>(0.05)</sub> Row width = 5.83  
LSD<sub>(0.05)</sub> Planting densities = 5.42  
LSD<sub>(0.05)</sub> RW x PD = ns

**Swellendam**

LSD<sub>(0.05)</sub> Row width = ns  
LSD<sub>(0.05)</sub> Planting densities = ns  
LSD<sub>(0.05)</sub> RW x PD = ns

Means within a row (planting density) and within a column (row width) indicated in bold, do not differ significantly if followed by the same letter.

At Caledon and Moorreesburg seedling numbers m<sup>-2</sup> were significantly affected as a result of the increasing row widths and planting densities, but significant planting density x row widths interactions (PD x RW) were also found (Table 4.6). At Caledon, seedling numbers m<sup>-2</sup> were not affected as a result of increasing row widths from 250 to 300 mm with the 100 and 175 target (no.) of plants m<sup>-2</sup> treatments. (Table 4.6), but at the 250 target (no.) of plants m<sup>-2</sup> treatment, seedling numbers decreased from 289 to 240 m<sup>-2</sup>, when row width was increased from 250 to 300 mm. At Moorreesburg, seedling numbers were also not affected due to the row width used at the 100 target (no.) of plants m<sup>-2</sup> treatment, but decreased from 205 to 193 seedlings m<sup>-2</sup> at the 175 target (no.) of plants m<sup>-2</sup> treatment when row width increased from 250 to 350 mm (Table 4.6). No significant differences were however found when row width was increased from 250 to 300 mm. The highest planting density treatment of 250 target (no.) of plants m<sup>-2</sup>, resulted in reduction from 297 seedlings m<sup>-2</sup> to 272 seedlings m<sup>-2</sup> when row width was increased from 250 mm to 300 mm, but no significant reduction was found when row width was increased to 350 mm.

**Table 4.6** Interactions between row widths and planting density for seedlings m<sup>-2</sup> and seedling survival (%) at Caledon and Moorreesburg in 2006

Row Width	Seedling number m <sup>-2</sup>				Seedling survival (%)			
	Planting density				Planting density			
	Target (no.) plants m <sup>-2</sup>				Target (no.) plants m <sup>-2</sup>			
<b>Caledon</b>								
	<b>100</b>	<b>175</b>	<b>250</b>	<b>Mean</b>	<b>100</b>	<b>175</b>	<b>250</b>	<b>Mean</b>
<b>250</b>	116a	195b	289c	<b>200a</b>	92.4a	89.1ab	92.6a	<b>91.4a</b>
<b>300</b>	106a	192b	240d	<b>176b</b>	84.5b	88.0ab	76.8c	<b>83.1b</b>
<b>Mean</b>	<b>111a</b>	<b>193b</b>	<b>264c</b>	<b>189</b>	<b>88.5</b>	<b>88.5</b>	<b>84.7</b>	<b>87.2</b>
<b>Moorreesburg</b>								
<b>250</b>	118a	205b	297d	<b>207a</b>	94.0a	93.9a	95.3a	<b>94.4</b>
<b>300</b>	120a	199bc	272e	<b>197b</b>	95.5a	90.7ab	87.4b	<b>91.2</b>
<b>350</b>	118a	193c	268e	<b>193b</b>	94.5a	88.1b	86.0b	<b>89.5</b>
<b>Mean</b>	<b>118a</b>	<b>199b</b>	<b>279c</b>	<b>199</b>	<b>94.7a</b>	<b>90.9b</b>	<b>89.5c</b>	<b>91.7</b>

Means within the interaction followed by the same letter do not differ significantly. Means within a row (planting density) and within a column (row width) indicated in bold, do not differ significantly if followed by the same letter.

**Caledon**

LSD<sub>(0.05)</sub> Row width = 6.21

LSD<sub>(0.05)</sub> Planting densities = 10.88

LSD<sub>(0.05)</sub> RW x PD = 13.48

LSD<sub>(0.05)</sub> Row width = 3.22

LSD<sub>(0.05)</sub> Planting densities = ns

LSD<sub>(0.05)</sub> RW x PD = 6.00

**Moorreesburg**

LSD<sub>(0.05)</sub> Row width = 9.11

LSD<sub>(0.05)</sub> Planting densities = 5.47

LSD<sub>(0.05)</sub> RW x PD = 11.27

LSD<sub>(0.05)</sub> Row width = ns

LSD<sub>(0.05)</sub> Planting densities = 2.43

LSD<sub>(0.05)</sub> RW x PD = 4.99

During 2005, significant differences in number of seedlings m<sup>-2</sup> due to the planting densities applied were found at all localities (Table 4.2). Seedling numbers m<sup>-2</sup> did not reach the targets set with different planting densities at Swellendam (Table 4.4). For the 150 target (no.) of plants m<sup>-2</sup> treatment, 119 seedlings m<sup>-2</sup> were counted, which was significantly lower than the 163 and 191 seedlings m<sup>-2</sup> counted for the 200 and 250 target (no.) of plants m<sup>-2</sup> treatments respectively. No significant differences between the two higher planting densities or interactions with row widths or cultivars were found.

At Caledon, Moorreesburg and Hopefield seedling numbers m<sup>-2</sup> increased significantly with increasing planting densities (Figure 4.1). At Moorreesburg and Hopefield seedling numbers m<sup>-2</sup> reached or exceeded the targets of the 100, 175 and 250 plants m<sup>-2</sup>, but at Caledon targets of 175 and 250 plants m<sup>-2</sup> treatments were not reached.

At Riversdale and Swellendam in 2006 seedling numbers m<sup>-2</sup> were significantly increased when plant densities were increased (Table 4.5). Target planting densities treatments of 100, 150 and 200 target (no.) of plants m<sup>-2</sup> at Riversdale and 150, 200 and 250 target (no.) of plants m<sup>-2</sup> at Swellendam were all exceeded, except for the 200 target (no.) of plants m<sup>-2</sup> treatment at Riversdale where 198 seedlings m<sup>-2</sup> were counted.

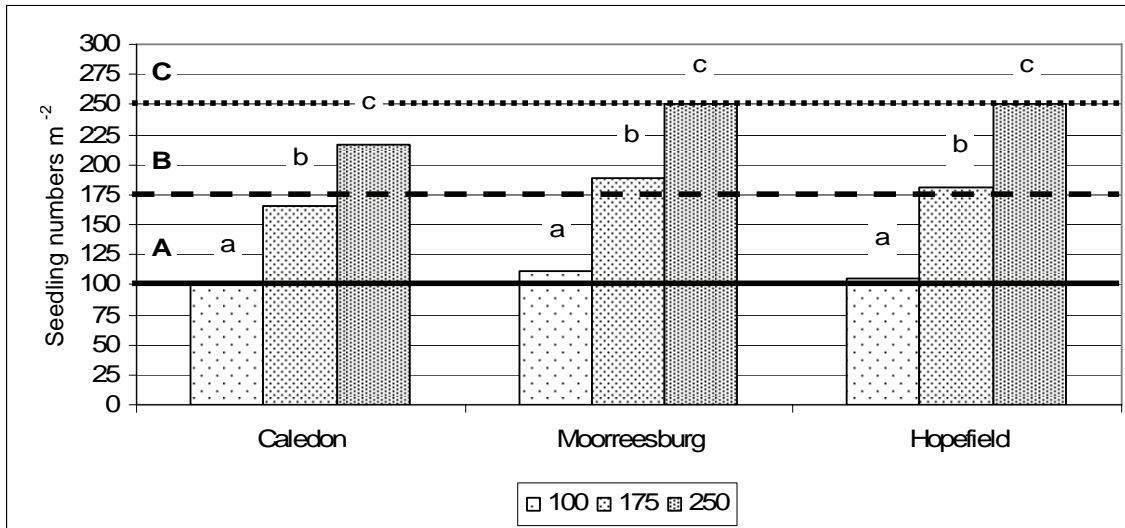

**Figure 4.1** Seedlings counted at the Caledon, Moorreesburg and Hopefield localities in 2005. Line A indicates the target of 100 plants m<sup>-2</sup>, Line B, 175 plants m<sup>-2</sup> and Line C, 250 plants m<sup>-2</sup>. LSD<sub>(0.05)</sub> Caledon = 14.65; LSD<sub>(0.05)</sub> Moorreesburg = 14.23; LSD<sub>(0.05)</sub> Hopefield = 12.72.

At Riversdale, 113 and 162 seedlings m<sup>-2</sup> were counted for the 100 and 150 target (no.) of plants m<sup>-2</sup> treatments, while 160, 211 and 258 seedlings m<sup>-2</sup> were counted for planting densities of 150, 200 and 250 target (no.) of plants m<sup>-2</sup> at Swellendam.

### **Seedling survival (%)**

*Cultivars did not have any effect on seedling survival (%) and no interactions between the factors cultivar, row width and planting density occurred (Table 4.2) in 2005. Seedling survival (%) was significantly influenced by cultivars at Hopefield in 2006, but no interactions between cultivars and row widths or planting densities were found. Row width influenced seedling survival (%) significantly at Swellendam in 2005 and Riversdale 2006. Significant planting density x row width (PD x RW) interactions were found at Caledon in and Moorreesburg in 2006. Planting density treatments influenced seedling survival significantly without interactions at Caledon and Moorreesburg in 2005 and at Riversdale in 2006.*

The only significant difference with regards to seedling survival (%) of cultivars was found at Hopefield in 2006 when 92.6% of SST 88 seedlings survived in comparison with 81.8% of SST 015 (Table 4.3). This was due to significant PD x RW interaction in which the cultivars differed in seedling numbers m<sup>-2</sup> at different planting densities.

During the 2005 season at Swellendam, seedling survival (%) decreased from 66.2% to 60.5% when row width was increased from 250 to 300 mm (Table 4.7).

**Table 4.7** The row width x planting density interaction for seedling survival (%) at Swellendam 2005

Row width (mm)	Planting density (Target (no.) plants m <sup>-2</sup> )			
	150	200	250	Mean
250	66.4	70.6	61.6	<b>66.2a</b>
300	61.0	60.1	60.4	<b>60.5b</b>
<b>Mean</b>	<b>63.7</b>	<b>65.4</b>	<b>61.0</b>	<b>63.4</b>

LSD<sub>(0.05)</sub> Row width = 5.61

LSD<sub>(0.05)</sub> Planting densities = ns

LSD<sub>(0.05)</sub> RW x PD = ns

Means within the interaction and for planting density did not differ significantly. Means for row width differed significantly and are followed by different letters

The generally low percentage seedling survival at this locality (trial average = 63.4%) may be due to a dry, but cold period that occurred in the latter part of May and the first week in June 2005 (Table 3.4, Figure 3.10).

At Riversdale in 2006, seedling survival was reduced by 7.4% from 88.8% to 81.4 % when the row width was increased from 250 mm to 300 mm (Table 4.5). Seedling survival was also significantly influenced in PD x RW interactions at Caledon and Moorreesburg in the same season (Table 4.6). At Caledon, the use of the wider row width (300 mm) reduced seedling survival significantly at the 100 and 250 target (no.) of plants m<sup>-2</sup> treatments, but not at the 175 target (no.) of plants m<sup>-2</sup> treatment. At Moorreesburg, seedling survival did not decrease with an increase in row width at the 100 target (no.) of plants m<sup>-2</sup> treatment. At 175 target (no.) of plants m<sup>-2</sup>, seedling survival only decreased when row widths of more than 300 mm were used, but at a density of 250 target (no.) of plants m<sup>-2</sup>, seedling survival decreased when row widths exceeded 250 mm.

Seedling survival (%) at Caledon and Moorreesburg in 2005 decreased significantly with increasing planting densities (Figure 4.2). Seedling survival (%) greater than 80% was achieved for all planting densities at Moorreesburg and Hopefield due to favourable conditions for germination and seedling emergence after planting (Table 3.5).

At Caledon, seedling survival (%) of less than 80% was measured (Figure 4.2) at the higher planting densities (175 and 250 target plants m<sup>-2</sup>), but a trial average of 75.4% was still achieved at this locality. Seedling emergence could have been hampered by cold, wet conditions which prevailed after planting (Table 3.4 and Figure 3.10).

At the highest planting density treatment (200 target (no.) of plants m<sup>-2</sup>) at Riversdale in 2006, seedling survival (%) was significantly reduced to 79.0% when compared to

89.8% and 86.4% survival at the 100 and 150 target (no.) of plants m<sup>-2</sup> treatments respectively (Table 4.5).

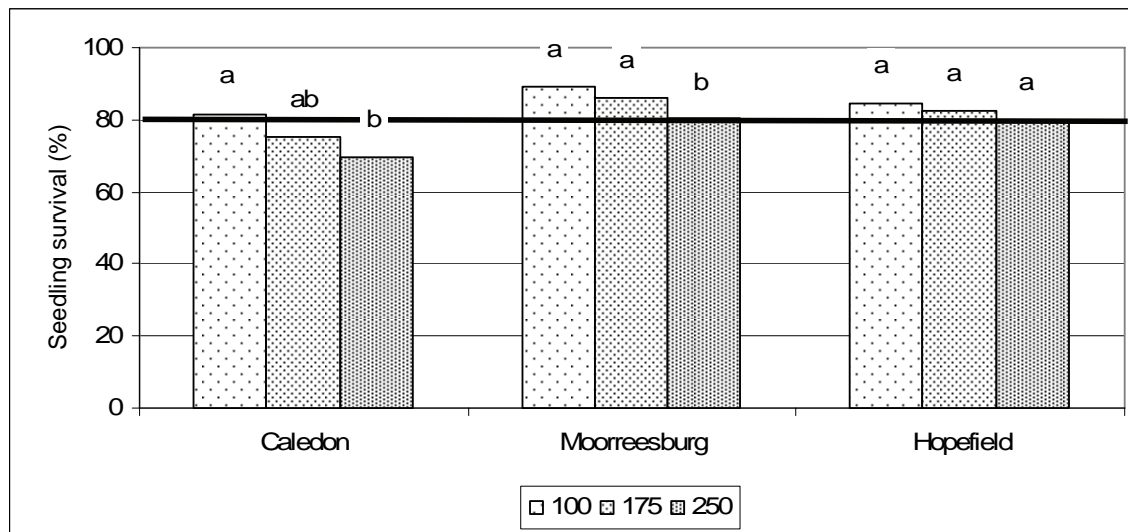

**Figure 4.2** Seedlings survival (%) at the Caledon, Moorreesburg and Hopefield localities in 2005. LSD<sub>(0.05)</sub> Caledon = 7.04; LSD<sub>(0.05)</sub> Moorreesburg = 2.53; LSD<sub>(0.05)</sub> Hopefield = 6.28.

No significant differences in seedling survival % ( $p > 0.05$ ) as a result of the treatments applied were found at Swellendam in 2006 (Tables 4.2 and 4.5). However, the trial average of 84.0% (Table 4.5) compared to 63.4% in 2005 (Table 4.7) indicated a positive response to the improved conditions for emergence and survival which prevailed in 2006 (Table 3.4, Figure 3.10).

## Discussion

Seedling numbers increased with increasing planting density treatments, similar to findings of Anderson and Barclay (1996) as well as Amjad and Anderson (2006), indicating that planting densities were effectively applied. However, seedling survival (%) decreased as a result of increased planting densities at some localities. This supports the results of Del Cima *et al.* (2004) in which an increase in planting density for 30-90 kg seed ha<sup>-1</sup> lead to a reduction in seedling survival of 36% (from 99 to 63%). Yunusa *et al.* (1993) suggested that decreases in seedling survival at higher planting densities may be the result of increased competition for water, as competition for light and nutrients would be minimal at this early growth stage.

In this study, seedling numbers m<sup>-2</sup> decreased as result of increased row widths at some localities like Swellendam 2005 and Riversdale 2006. At other localities like Caledon and Moorreesburg 2006 these decreases were only true for the higher planting densities, while no significant reduction was found at Swellendam 2006. Anderson (1986), Del

Cima *et al.* (2004) as well as Amjad and Anderson (2006) also reported decreases in seedling survival due to increasing row widths in Australia, while Schoonwinkel *et al.* (1991) did not find such a reduction in a 3 years study in the Swartland when row width was increased from 175 to 350 mm. These contrasting results indicated that the response in seedling numbers and survival due to row spacing is also affected by climatic and/or soil conditions during or after planting. Holliday (1963) and Satorre (1999) suggests that reduced seedling survival in wide row widths are the result of increased competition due to increased crowding at an early stage.

The lowest overall seedling survival of 63.4% found at Swellendam 2005 could have been partly due to the low rainfall (30 mm) received during April. Although 38 mm was received during the germination period, this rainfall coincided with a cold 10-day period at the end of May which might have delayed germination and emergence as Carr *et al.* (2003) found that the establishment of hard red spring wheat was reduced when cold and wet conditions prevailed after planting. Much improved moisture conditions and temperature regimes prevailed at this locality in 2006 and seedling survival of 84.0% was achieved.

Although the two localities in the Swartland also had very dry conditions prior to planting in 2006, sufficient rainfall in May and follow up rain in June, ensured excellent overall seedling survival with 91.7% at Moorreesburg and 87.2% at Hopefield. In these conditions, seedling survival was not significantly reduced by increasing row width at Hopefield, but at Moorreesburg seedling survival was influenced when high planting densities were used, indicating that competition for resources could have had an effect, even in the presence of conditions that favoured germination.

Although the cultivars used at Hopefield in 2006 did differ in their response to increasing planting densities, such differences were not found at any of the other localities. This result support the findings of Carr *et al.* (2003), who found significant cultivar x planting density interactions for seedling survival of hard red spring wheat, but according to Anderson and Barclay (1991) cultivars, in general did not differ in their seedling survival response to planting densities. The use of good quality seed with high germination percentage for all cultivars would however be a prerequisite in such comparisons.

It must be kept in mind that the reduced seedling survival rate at high planting densities does not normally result in insufficient stand. For instance, the low seedling survival rate of 61.6% determined at the 250 target (no.) of plants  $m^{-2}$  treatment in the 250 mm row width at Swellendam in 2005 resulted in 192 seedlings  $m^{-2}$  which can be considered a more than sufficient stand for this production area (Agenbag, 1992). In contrast, the 124

seedlings counted at the 150 target (no.) of plants m<sup>-2</sup> treatment in the same row width, can be considered an insufficient stand according to Agenbag (1992) who recommended at least 150-175 established plants m<sup>-2</sup> for marginal production regions.

### **Conclusion**

In spite of the above mentioned decreases in seedling survival due to increased planting densities and row widths, survival of 80% was achieved in all trials with the exception of Caledon and Swellendam in 2005. Yunusa *et al.* (1993) also indicated satisfactory seedling survival (above 80%) in most circumstances with the use of wide rows in the dry Western Australian environment. No-till planting methods and seeding equipment may for this reason be efficient to improve on plant establishment of 50-70%, often found for conventional planting methods (Laubscher 1986; Maali & Agenbag, 2004).

## CHAPTER 5

### THE INFLUENCE OF PLANTING DENSITY AND ROW WIDTH ON WHEAT IN CONSERVATION TILLAGE SYSTEMS IN THE WESTERN CAPE. PART 2: YIELD COMPONENTS IN THE SOUTHERN CAPE.

#### Introduction

When plants are arranged in a grid-like fashion or spread out more or less evenly (as happens in the broadcast planting method), competition between individual plants for resources (water and nutrition) is minimised (Holliday, 1963). With such arrangements, high planting densities can be used to increase the number of heads per unit area to compensate for low survival rates (Laubscher, 1986; Agenbag, 1992). The use of a planter implies that seeds are placed in rows and the competition between individual plants increases due to crowding in the row if the planting densities are used. The wider the row width, the greater the competition will be. Row widths used in conventional cropping systems in Mediterranean environments have always been kept to the minimum (175-180 mm). Conservation tillage, however requires the use of wider row widths for increased stubble handling, in which increased competition between plants in the row is a given. In this chapter, the influence of the use of wide row widths in combination with different planting densities and cultivars on the components of yield (the number of heads  $\text{m}^{-2}$ , the number of heads  $\text{plant}^{-1}$ , the number kernels  $\text{head}^{-1}$  and kernel weight) in the Southern Cape region will be discussed.

#### Experimental procedure

The experimental procedure is described in Chapter 3, but a summary of localities, treatments and data collected (to be discussed in this Chapter) is given in Table 5.1.



**Table 5.1** Summary of localities, seasons, treatments and data collected at the Southern Cape localities

Locality	Treatments	Data collected
<b>Riversdale</b>	<b>Cultivars:</b>	Heads m <sup>-2</sup>
	2006 – SST 88, SST 57, SST 015	Heads plant <sup>-1</sup>
	<b>Row widths:</b>	Kernels head <sup>-1</sup>
	250 and 300 mm	Kernel weight
	<b>Planting densities:</b>	
	100, 150 and 200 target (no.) of plants m <sup>-2</sup> .	
<b>Swellendam</b>	<b>Cultivars:</b>	Heads m <sup>-2</sup>
	2005 – SST 88, SST 94	Heads plant <sup>-1</sup>
	2006 – SST 88, SST 57, SST 015	
	<b>Row widths:</b>	Only in 2006:
	250 and 300 mm	Kernels head <sup>-1</sup>
	<b>Planting densities:</b>	Kernel weight
	150, 200 and 250 target (no.) of plants m <sup>-2</sup> .	
<b>Caledon</b>	<b>Cultivars:</b>	Heads m <sup>-2</sup>
	2005 – SST 88, SST 57, SST 94	Heads plant <sup>-1</sup>
	2006 – SST 88, SST 57, SST 015	Kernels head <sup>-1</sup>
	<b>Row widths:</b>	Kernel weight
	250 and 300 mm	
	<b>Planting densities:</b>	
	100, 175 and 250 target (no.) of plants m <sup>-2</sup> .	

## Results

The number of heads m<sup>-2</sup>, number of heads plant<sup>-1</sup>, number of kernels head<sup>-1</sup> and kernel weight at different localities and years were significantly affected as a result of the treatments applied (Table 5.2).

### ***The number of heads m<sup>-2</sup>***

*Cultivars did not differ significantly with regard to the number of heads m<sup>-2</sup> counted at any locality or in any season and no interaction between cultivars and row widths or planting densities was found (Table 5.2). This yield component was however significantly influenced by row width in both seasons at Riversdale and Swellendam and at Caledon in 2006. Planting density significantly influenced the number of heads m<sup>-2</sup> at Swellendam and at Caledon during 2005 and 2006, but no RW x PD interactions were found at any locality in any of the seasons.*

The fact that cultivars did not differ significantly ( $p > 0.05$ ) with regard to the number of heads m<sup>-2</sup> (Table 5.2) and no significant interactions were found, indicated that although soil and climatic conditions in these trials varied largely, cultivar responses were similar or that this yield component is dominated by the number of plants m<sup>-2</sup>.

**Table 5.2** Pr >F values and coefficients of variance of the main effects and interactions for heads m<sup>-2</sup>, heads plant<sup>-1</sup>, kernels head<sup>-1</sup> and kernel weight in the Southern Cape trials during 2005 and 2006

	2005		2006		
	Swellendam	Caledon	Riversdale	Swellendam	Caledon
	<b>Heads m<sup>-2</sup></b>				
<b>Cultivar</b>	ns	ns	ns	ns	ns
<b>Row width</b>	<0.001	ns	0.003	<0.001	0.002
<b>RW x CV</b>	ns	ns	ns	ns	ns
<b>Planting Density</b>	0.002	0.045	ns	0.004	<0.001
<b>PD x CV</b>	ns	ns	ns	ns	ns
<b>PD x RW</b>	ns	ns	ns	ns	ns
<b>PD x RW x CV</b>	ns	ns	ns	ns	ns
<b>Cv (%)</b>	<b>15</b>	<b>11.8</b>	<b>8.2</b>	<b>9.2</b>	<b>6.8</b>
<b>Appendix no.</b>	<b>B-1</b>	<b>B-2</b>	<b>B-3</b>	<b>B-4</b>	<b>B-5</b>
	<b>Heads plant<sup>-1</sup></b>				
<b>Cultivar</b>	ns	ns	ns	ns	ns
<b>Row width</b>	ns	ns	ns	ns	ns
<b>RW x CV</b>	0.042	ns	ns	ns	ns
<b>Planting Density</b>	<0.001	<0.001	<0.001	<0.001	<0.001
<b>PD x CV</b>	0.020	ns	ns	ns	ns
<b>PD x RW</b>	ns	ns	ns	ns	ns
<b>PD x RW x CV</b>	ns	ns	ns	ns	ns
<b>Cv (%)</b>	<b>16</b>	<b>19.8</b>	<b>12.5</b>	<b>13.5</b>	<b>13.3</b>
<b>Appendix no.</b>	<b>B-6</b>	<b>B-7</b>	<b>B-8</b>	<b>B-9</b>	<b>B-10</b>

**Table 5.2 (continued)** Pr>F values and coefficients of variance of the main effects and interactions for heads m<sup>-2</sup>, heads plant<sup>-1</sup>, kernels head<sup>-1</sup> and kernel weight in the Southern Cape trials during 2005 and 2006

	2005		2006		
	Swellendam	Caledon	Riversdale	Swellendam	Caledon
<b>Kernels head<sup>-1</sup></b>					
<b>Cultivar</b>	nd	ns	<0.001	0.009	0.037
<b>Row width</b>	nd	ns	0.022	ns	ns
<b>RW x CV</b>	nd	ns	ns	ns	ns
<b>Planting Density</b>	nd	<0.001	ns	0.022	ns
<b>PD x CV</b>	nd	ns	ns	0.006	ns
<b>PD x RW</b>	nd	ns	ns	ns	ns
<b>PD x RW x CV</b>	nd	ns	ns	0.040	ns
<b>Cv (%)</b>	-	<b>10.7</b>	<b>14.7</b>	<b>10.1</b>	<b>12.7</b>
<b>Appendix no.</b>	-	<b>B-11</b>	<b>B-12</b>	<b>B-13</b>	<b>B-14</b>
<b>Kernel weight (g 1000 kernels<sup>-1</sup>)</b>					
<b>Cultivar</b>	nd	<0.001	<0.001	<0.001	<0.001
<b>Row width</b>	nd	ns	0.041	ns	ns
<b>RW x CV</b>	nd	ns	ns	ns	ns
<b>Planting Density</b>	nd	ns	ns	ns	<0.001
<b>PD x CV</b>	nd	ns	0.012	ns	ns
<b>PD x RW</b>	nd	ns	ns	ns	ns
<b>PD x RW x CV</b>	nd	ns	ns	ns	ns
<b>Cv (%)</b>	-	<b>2.3</b>	<b>3.8</b>	<b>3.4</b>	<b>2.7</b>
<b>Appendix no.</b>	-	<b>B-15</b>	<b>B-16</b>	<b>B-17</b>	<b>B-18</b>

CV=Cultivar, RW=row width, PD=planting density and Cv (%) = the coefficient of variance.  
nd = not determined

Due to the low rainfall at the Swellendam locality during the period of July to September in 2005 (Table 3.4), the average number of heads m<sup>-2</sup> was very low and an increase in row width from 250 mm to 300 mm significantly reduced the number of heads from 155 to 128 heads m<sup>-2</sup> (Figure 5.1).

Growth conditions at Caledon during 2005 were more favourable with a dry period only in July (Table 3.4) and the number of heads m<sup>-2</sup> were not significantly (p<0.05) reduced (Figure 5.1) by increasing row width. Although favourable growth conditions were

experienced at all three localities in 2006 because of generally high rainfall, the number of heads  $m^{-2}$  was significantly reduced by an increase in row width at Riversdale (320 to 286), Swellendam (257 to 226) and Caledon (370 to 336). This is an indication that increased crowding in wider rows did result in higher inter-plant competition which had a negative effect on the number of heads  $m^{-2}$ .

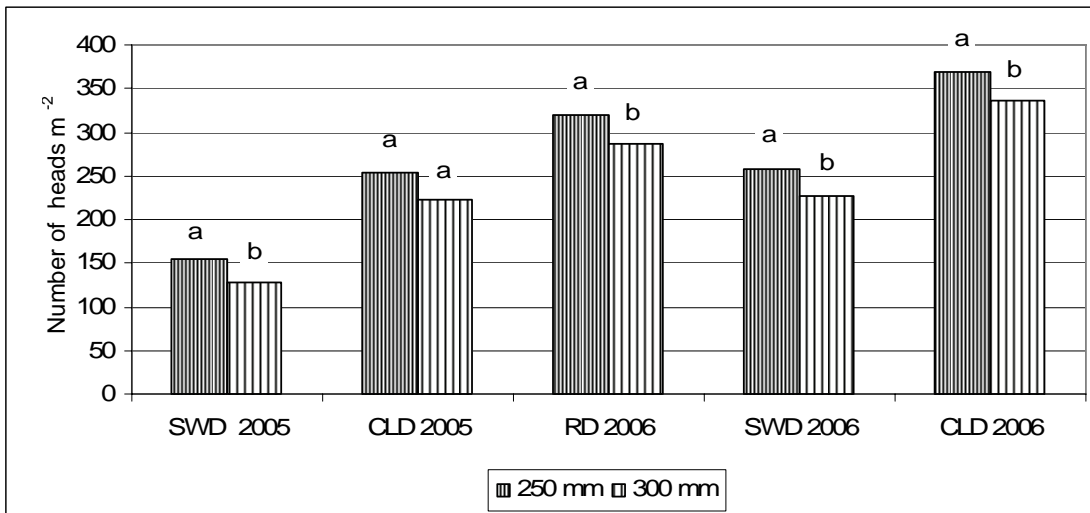

**Figure 5.1** The influence of row width on the number of heads  $m^{-2}$  at the Southern Cape localities 2005-2006. SWD= Swellendam, CLD = Caledon, RD = Riversdale. LSD  $_{(0.05)}$  SWD 2005 = 6.93, RD 2006 = 17.04, SWD 2006 = 13.45, Cal 2006 = 15.15

The number of heads  $m^{-2}$  at the Riversdale locality in 2006 was not significantly ( $p > 0.05$ ) affected by planting density (Table 5.3) and a relatively high number of heads  $m^{-2}$  (trial average = 303) were produced, indicating that plants were able to compensate for reduced number of plants  $m^{-2}$  during this season by means of increased tillering. Due to high rainfall (Table 3.4), growth conditions remained favourable with no dry periods from planting to mid-September with the result that tiller abscission was most probably also low.

At Swellendam an increase in planting density resulted in a significant reduction in the number of heads  $m^{-2}$  in 2005 and a significant increase in 2006 (Table 5.3). During 2005, significantly more heads (143 and 160 heads  $m^{-2}$ ) were produced as a result of the 150 and 200 target (no.) plants  $m^{-2}$  treatments compared to the 122 heads  $m^{-2}$  at the highest planting density of 250 target (no.) plants  $m^{-2}$ . These results indicated that the optimum planting density for the conditions which prevailed during 2005, was exceeded at the highest planting density. The resultant increased competition most probably lead to increased tiller mortality during the unfavourable soil water conditions that prevailed due to the low rainfall at this site from the end of June to harvesting (Table 3.4). Although still fewer when compared to Caledon and Riversdale in 2006, more heads  $m^{-2}$  (mean of 242 heads  $m^{-2}$ ) were produced at Swellendam in 2006, compared to 2005

(Table 5.3). During 2006, the highest planting density of 250 target (no.) plants m<sup>-2</sup> produced 256 heads m<sup>-2</sup> which were significantly more than the 228 heads m<sup>-2</sup> produced at the lowest density of 150 target (no.) plants m<sup>-2</sup>.

**Table 5.3** The influence of target planting density on heads m<sup>-2</sup> and heads plant<sup>-1</sup> at Riversdale, Swellendam and Caledon for the 2005 and 2006 seasons

Planting density (target (no.) of plants m <sup>-2</sup> )	2005		2006	
	Heads m <sup>-2</sup>	Heads plant <sup>-1</sup>	Heads m <sup>-2</sup>	Heads plant <sup>-1</sup>
<b>Riversdale</b>				
100	-	-	301a	2.69a
150	-	-	304a	1.90b
200	-	-	305a	1.58c
<b>Average</b>	-	-	<b>303</b>	<b>2.06</b>
<b>LSD<sub>(0.05)</sub></b>	-	-	<b>ns</b>	<b>0.1768</b>
<b>Swellendam</b>				
150	143a	1.2 a	228 a	1.4 a
200	160a	1.0 b	242 ab	1.2 b
250	122 b	0.6 c	256 b	1.0 c
<b>Average</b>	<b>142</b>	<b>1.0</b>	<b>242</b>	<b>1.28</b>
<b>LSD<sub>(0.05)</sub></b>	<b>18.38</b>	<b>0.1319</b>	<b>15.24</b>	<b>0.1124</b>
<b>Caledon</b>				
100	232a	2.3 a	339 a	3.0 a
175	230a	1.4 b	357 b	1.9 b
250	253 b	1.2 c	371 b	1.4 c
<b>Average</b>	<b>238</b>	<b>1.6</b>	<b>353</b>	<b>2.1</b>
<b>LSD<sub>(0.05)</sub></b>	<b>19.43</b>	<b>0.2200</b>	<b>16.49</b>	<b>0.1920</b>

Means within each column followed by the same letter are not significantly different from each other.

At Caledon in 2005, significantly more heads (253 heads m<sup>-2</sup>) were produced at the highest planting density treatment of 250 target (no.) of plants m<sup>-2</sup> compared to the 230 and 232 heads m<sup>-2</sup> respectively produced at the intermediate and the lowest planting densities of 175 and 100 target (no.) of plants m<sup>-2</sup> (Table 5.3). During the 2006 season, only the lowest planting density of 100 target (no.) of plants m<sup>-2</sup> resulted in significantly

fewer heads (339 heads m<sup>-2</sup>) compared to the intermediate (357 heads m<sup>-2</sup>) and highest (371 heads m<sup>-2</sup>) target planting densities of 175 and 250 target (no.) of plants m<sup>-2</sup>.

Although 2005 was a more favourable season than 2006 in terms of pre- and in-season rainfall at this site, the dry period that prevailed from the end of June to the first ten days of August in 2005 (Figure 3.7) would have increased tiller mortality and therefore reduced the number of head bearing tillers as indicated by the difference in the trial averages between the two seasons (Table 5.3). Increasing trends with increasing plant densities however showed that the number of plants m<sup>-2</sup> were the determining factor for differences in heads m<sup>-2</sup> in both years.

### ***The number of heads plant<sup>-1</sup>***

*Neither cultivars nor row widths influenced the number of heads plant<sup>-1</sup> at any locality or in any season (Table 5.2) except at Swellendam when significant interactions between cultivars and row widths (RW x CV) and between cultivars and planting densities (PD x CV) were found in 2005. This yield component was however, significantly influenced by planting density in all seasons and all localities.*

The cultivar row width interaction at Swellendam in 2005 (Table 5.4) indicates that for both cultivars, the number of heads plant<sup>-1</sup> did not differ significantly if row width increased from 250 mm to 300 mm, but that SST 94 had significantly more heads plant<sup>-1</sup> (1.1) than SST 88 (0.8) when the wider row width was used.

**Table 5.4** The interactions of cultivars x planting density and cultivar x row width for heads plant<sup>-1</sup> at Swellendam 2005

Cultivar	Row width (mm)		Target planting density (plants m <sup>-2</sup> )			Cultivar Mean
	250	300	150	200	250	
<b>SST 88</b>	0.9 ab	0.8 b	1.0 a	0.9 ac	0.6 c	0.9
<b>SST 94</b>	1.0 a	1.1 a	1.4 b	1.1 ab	0.7 c	1.0
<b>Mean</b>	<b>1.0</b>	<b>0.9</b>	<b>1.2 a</b>	<b>1.0ab</b>	<b>0.6 c</b>	1.0

LSD<sub>(0.05)</sub> Cultivars = ns

LSD<sub>(0.05)</sub> CV x RW = 0.1585

LSD<sub>(0.05)</sub> Row width = ns

LSD<sub>(0.05)</sub> CV x PD = 0.3897

LSD<sub>(0.05)</sub> Planting density = 0.1319

Means within the each interaction followed by the same letter do not differ significantly from each other.

Means within the same row (target planting densities) followed by the same letter do not differ significantly from each other.

The cultivar x planting density interaction (Table 5.4) showed that SST 94 formed significantly more heads plant<sup>-1</sup> (1.4) compared to SST 88 (1.0) at the lowest planting density of 150 target (no.) of plants m<sup>-2</sup>, but heads plant<sup>-1</sup> measured did not differ

between the cultivars ( $p > 0.05$ ) when higher planting densities of 200 and 250 target (no.) of plants  $m^{-2}$  were used.

For both cultivars, the number heads  $plant^{-1}$  was significantly reduced as planting density increased (Table 5.4). For the cultivar SST 88, the 0.9 heads  $plant^{-1}$  found with the intermediate planting density of 200 target (no.) of plants  $m^{-2}$  were not significantly different from the 1.0 and 0.6 heads  $plant^{-1}$  produced at respectively the lowest planting density of 150 target (no.) of plants  $m^{-2}$  and the highest planting density of 250 target (no.) of plants  $m^{-2}$ . In the case of SST 94, the two lower planting densities (150 and 200 target (no.) of plants  $m^{-2}$  treatments) did not differ significantly from each other (1.4 and 1.1 heads  $plant^{-1}$  respectively), but were both significantly higher compared to the 0.7 heads  $plant^{-1}$  produced at the highest planting density of 250 target (no.) of plants  $m^{-2}$ .

These interactions indicate that the two cultivars responded differently to the severe inter-plant competition for growth factors such as moisture, nutrients and light caused by the increased crowding due to the increased row width and high planting densities. From these results, SST 94 seemed to be better adapted to these conditions.

The number of heads  $plant^{-1}$  decreased significantly with increasing planting densities during all seasons and at all localities (Table 5.3). At Caledon, the reduction in number of heads  $plant^{-1}$  ranged from 2.3 at the lowest planting density of 100 target (no.) of plants  $m^{-2}$  to 1.2 at the highest planting density of 250 target (no.) of plants  $m^{-2}$  during 2005 (Table 5.3). At Riversdale (2006) the number of heads  $plant^{-1}$  was reduced from 2.7 to 1.6 when planting densities were increased from 100 to 200 target (no.) of plants  $m^{-2}$  (Table 5.3). Similar reductions were found at Swellendam during 2006 when the number of heads  $plant^{-1}$  was reduced from 1.4 to 1.0 when planting density increased from 150 to 250 target (no.) plants  $m^{-2}$  and at Caledon (2006) the reduction ranged from 3.0 to 1.4 heads  $plant^{-1}$  when planting densities increased from 100 to 250 target (no.) of plants  $m^{-2}$ .

#### ***The number of kernels head<sup>-1</sup>***

*The number of kernels head<sup>-1</sup> was not determined at the Swellendam site during 2005 (Table 5.2). At Caledon, cultivars did not differ significantly for this yield component during 2005, but in 2006, significant differences in cultivar responses were found at Riversdale and at Caledon. A significant planting density x row width x cultivar interaction (PD x RW x CV) was found at Swellendam 2006. A significant response in the number of kernels head<sup>-1</sup> to increasing row width was found in 2006 at Riversdale. A significant response to planting density was found at Caledon in 2005.*

At Riversdale (2006) SST 015 produced significantly fewer kernels head<sup>-1</sup> (21.7) when compared to SST 57 (28.4) and SST 88 (30.2) respectively, but no difference was found between SST 57 and SST 88 (Figure 5.2). A similar response was found at Caledon in 2006.

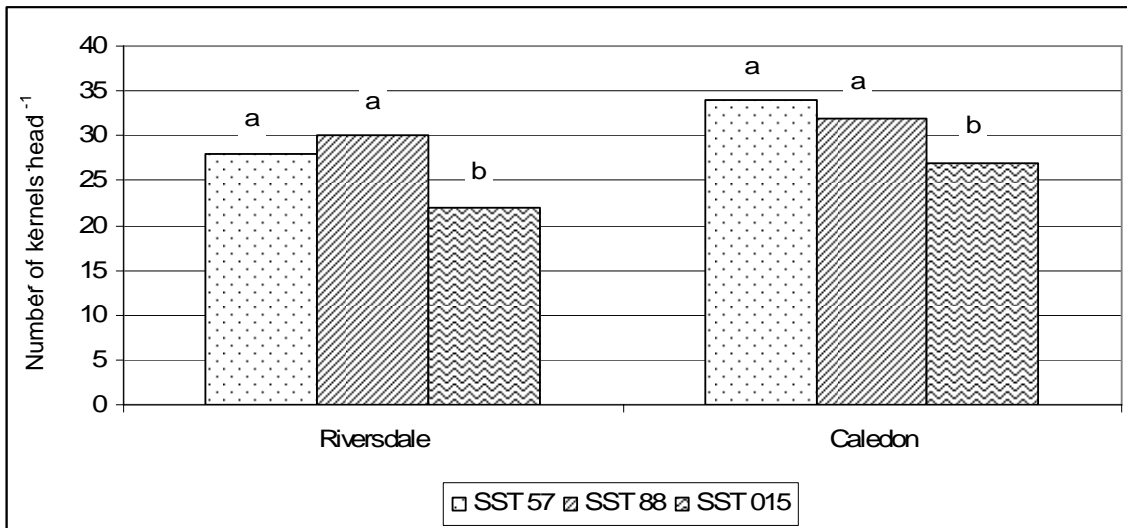

**Figure 5.2** Kernels head<sup>-1</sup> of different cultivars at the Riversdale and Caledon sites in 2006. LSD<sub>(0.05)</sub> Riversdale = 2.045, LSD<sub>(0.05)</sub> Caledon = 5.022.

Cultivars responded differently in terms of kernels head<sup>-1</sup> to increasing planting density and increasing row widths causing a significant planting density x row width x cultivar interaction at Swellendam 2006 (Figures 5.3 a, b, c).

SST 015 responded similarly to increasing planting density at both row widths (250 and 300 mm) with the lowest planting density having significantly more kernels head<sup>-1</sup> than the highest density (Figure 5.3 a). SST 57 responded differently with a significantly higher number of kernels head<sup>-1</sup> at the medium planting density of 200 target (no.) of plants m<sup>-2</sup> compared to the low and the high planting densities (150 and 250 target (no.) of plants m<sup>-2</sup> respectively) when the narrow row width (250 mm) was used (Figure 5.3b). However, no significant response was found at the wider (300 mm) row width for this cultivar. When planted in narrow (250 mm) row widths, SST 88 (Figure 5.3c) produced significantly more kernels head<sup>-1</sup> (>30) at the lowest planting density of 100 target (no.) of plants m<sup>-2</sup>, compared to the medium and the highest densities (200 and 250 target (no.) of plants m<sup>-2</sup>). No response was however found at the wide row width when planting density was increased with this cultivar.



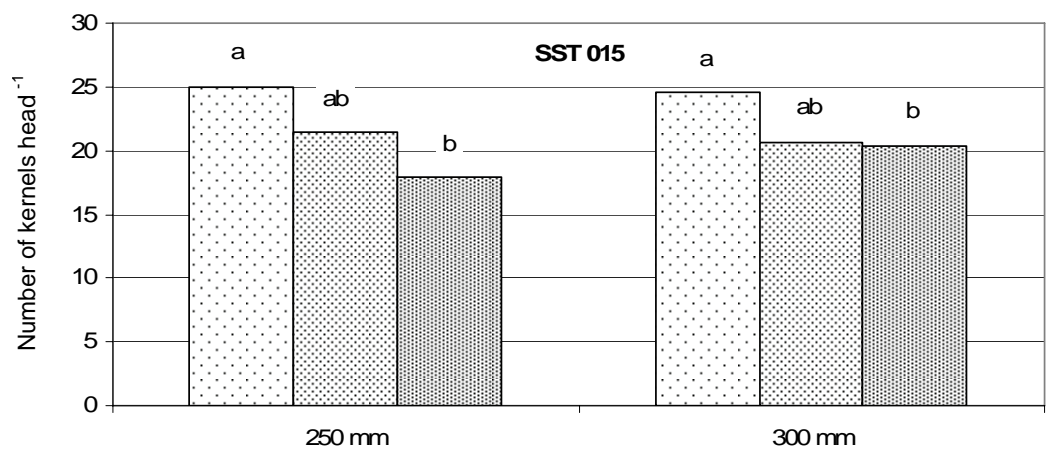

Figure 5.3 a

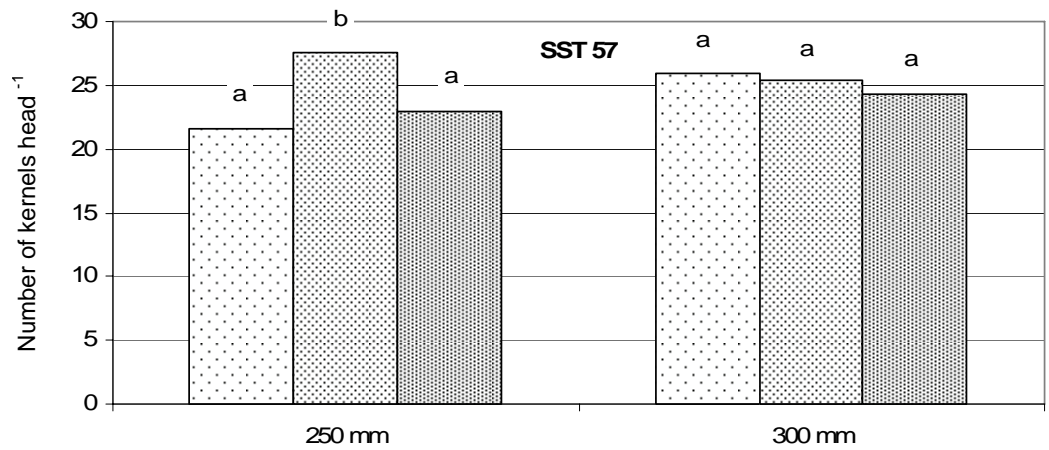

Figure 5.3 b

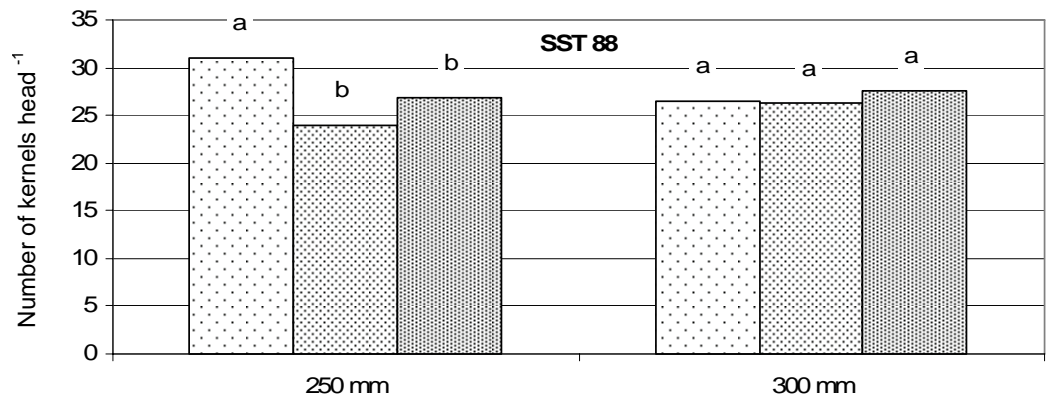
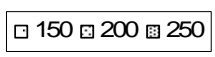
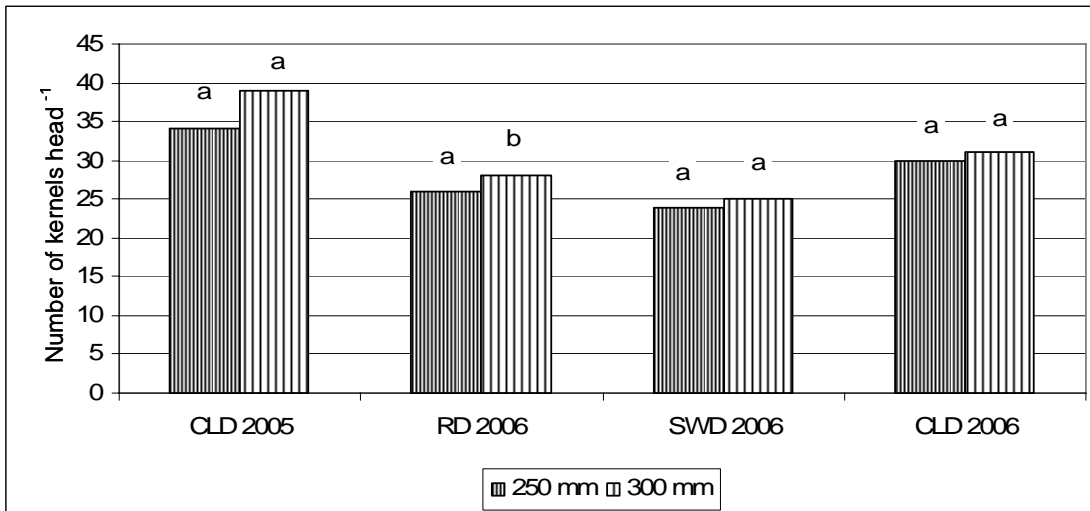

Figure 5.3 c



**Figures 5.3 a, b and c.** The planting density x row width x cultivar interaction for the number of kernels m<sup>-2</sup> at Swellendam in 2006. Planting densities (in the legend) represent 150, 200 and 250 target (no.) of plants m<sup>-2</sup> treatments. Row widths indicated is 250 and 300 mm. Figure 5.3a= SST 015, 5.3b=SST 57, SST 5.3c=SST 88. LSD<sub>(0.05)</sub> PD x RW x CV interaction = 4.13.

At Riversdale 2006, the wider (300 mm) row width produced 27.67 kernels head<sup>-1</sup>, which was significantly more than at the narrower row width (250 mm) where 25.87 kernels head<sup>-1</sup> were produced (Figure 5.4). This is an indication that compensation for the reduced number of heads m<sup>-2</sup> at the increased row width (Figure 5.4) did occur by means of significantly more kernels head<sup>-1</sup>.



**Figure 5.4** The influence of row width on the number of heads m<sup>-2</sup> at the Southern Cape localities 2005-2006. SWD= Swellendam, CLD = Caledon, RD = Riversdale. LSD<sub>(0.05)</sub> RW 2006 = 1.438.

The number of kernels head<sup>-1</sup> decreased significantly with an increase in planting density at Caledon 2005 (Table 5.5).

**Table 5.5** The treatment means of number of kernels head<sup>-1</sup> for planting densities at Caledon 2005

Cultivar	Caledon 2005			
	Target (no.) of plants m <sup>-2</sup>			
	100	175	250	Mean
<b>SST 88</b>	35.6	37.0	32.2	<b>34.9</b>
<b>SST 57</b>	39.6	36.1	34.7	<b>36.8</b>
<b>SST 94</b>	42.7	36.5	31.4	<b>36.9</b>
<b>Mean</b>	<b>39.3 a</b>	<b>36.5 b</b>	<b>32.7 c</b>	<b>36.2</b>

LSD<sub>(0.05)</sub> Cultivars = ns

LSD<sub>(0.05)</sub> Planting density = 2.659

LSD<sub>(0.05)</sub> CV X PD = ns

Means within the same row (planting densities) followed by the same letter do not differ significantly from each other.

When planting density increased from the lowest planting density of 100 target (no.) of plants m<sup>-2</sup> to 175 target (no.) of plants m<sup>-2</sup>, the number of kernels head<sup>-1</sup> decreased significantly from 39.3 to 36.5. A further increase in planting density to 250 target (no.) of plants m<sup>-2</sup> resulted in a further decrease to 32.7 kernels head<sup>-1</sup>.

### Thousand Kernel Mass

Cultivars differed significantly in kernel weight, measured by Thousand kernel mass (TKM) at Caledon in 2005 and at all localities during 2006 (Table 5.2). Cultivars were involved in a significant interaction with planting density (CV x PD) at Riversdale 2006. TKM was also significantly influenced by row width at Riversdale and Caledon in 2006.

At Caledon in 2005 (Table 5.6), TKM of both SST 57 (41.80 g) and SST 94 (41.84 g) were significantly lower than that of SST 88 (45.72 g). During 2006, TKM of SST 57 was also significantly lower than the other cultivars (SST 88 and SST015) at Swellendam and Caledon. At Swellendam, the TKM of SST 88 (42.16 g) was significantly higher than that of SST 015 (39.94 g), but at Caledon, SST 015 (46.59 g) outyielded SST 88 (41.90 g) in this regard.

**Table 5.6** Thousand kernel mass (g) for cultivars at the Southern Cape localities in 2005 and 2006

Cultivar	2005	2006	
	Caledon	Swellendam	Caledon
<b>SST 57</b>	41.80a	30.00a	35.00a
<b>SST 94</b>	41.84a	-	-
<b>SST 88</b>	45.72b	42.16b	41.90b
<b>SST 015</b>	-	39.94c	46.59c
<b>LSD</b> (0.05)	1.126	1.077	1.844

Means within each column followed by the same letter does not differ significantly from each other.

(-) = no data

At Riversdale in 2006 (Figure 5.5), SST 57 showed no significant TKM response to increasing planting densities, but the TKM of cultivar SST 015 decreased as a result of an increase in planting density from 100 to 150 target (no.) of plants m<sup>-2</sup>. In contrast to this, TKM of SST 88 gradually increased with increasing planting densities.

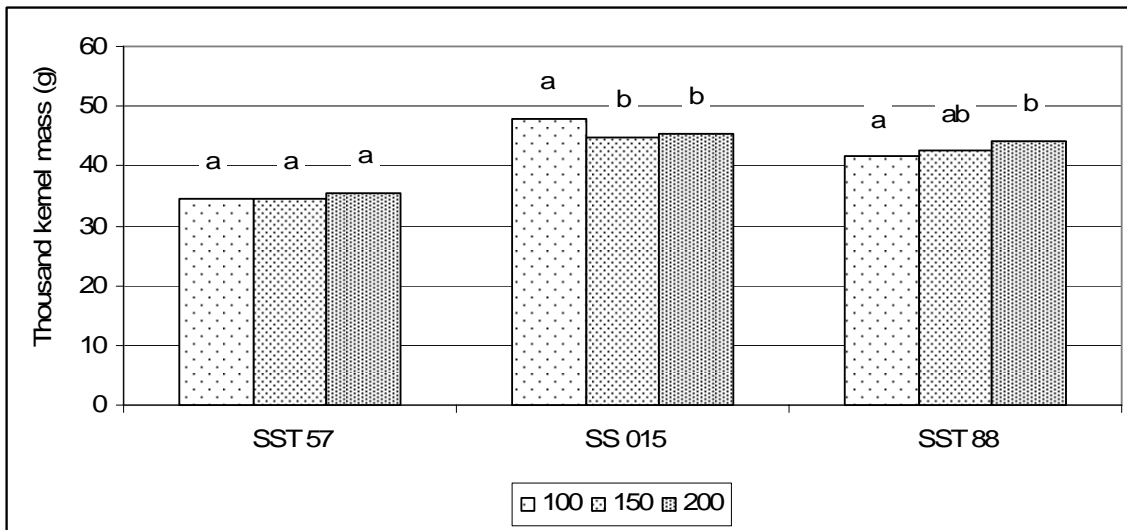

**Figure 5.5** The cultivar x planting density interaction for Thousand Kernel Mass (g) at different planting densities (100, 150 and 200 target (no.) of plants  $m^{-2}$ ) at the Riversdale locality in 2006.  $LSD_{(0.05)} PD \times CV$  interaction = 1.828.

During 2006, TKM at Riversdale increased from 40.99 g to 41.43 g due to the increase in row width from 250 mm to 350 mm, but planting density did not have any effect (Table 5.7).

**Table 5.7** Thousand kernel mass (g) for row width and planting density at Riversdale and Caledon 2006

Row width (mm)	Riversdale				Caledon			
	Target (no.) of plants $m^{-2}$				Target (no.) of plants $m^{-2}$			
	100	150	200	Mean	100	175	250	Mean
<b>250</b>	41.18	40.09	41.71	<b>40.99 a</b>	41.93	41.04	41.02	<b>41.33</b>
<b>300</b>	41.72	41.22	41.36	<b>41.43 b</b>	42.44	40.42	40.11	<b>40.99</b>
<b>Mean</b>	<b>41.45</b>	<b>40.66</b>	<b>41.53</b>	<b>41.21</b>	<b>42.09 a</b>	<b>40.73 b</b>	<b>40.57 b</b>	<b>41.16</b>

$LSD_{(0.05)}$  Row width = 0.415

$LSD_{(0.05)}$  Planting density = ns

$LSD_{(0.05)}$  RW X PD = ns

$LSD_{(0.05)}$  Row width = ns

$LSD_{(0.05)}$  Planting density = 0.753

$LSD_{(0.05)}$  RW X PD = ns

At Caledon in 2006 (Table 5.7), the highest TKM of 42.09 g was obtained with lowest planting density of 100 target (no.) of plants  $m^{-2}$  compared to 40.73 and 40.57 g respectively from the densities of 175 and 250 target (no.) of plants  $m^{-2}$ .

## Discussion

### **Cultivar response**

Cultivars (CV) used in these experiments did not differ significantly in terms of the number of heads  $m^{-2}$  and no interactions between row widths (RW) and cultivars (RW x CV) or between planting densities (PD) and cultivars (PD x CV) were found in this study. In contrast with these findings, Anderson (1986) as well as Anderson and Barclay (1991) found that spring wheat cultivars did differ in their response in terms of number of heads  $m^{-2}$  produced as planting density increased in dry Western Australian (Mediterranean) environments. In other regions, Johnson *et al.* (1988) and Carr *et al.* (2003) also reported significant differences in terms of the number of tillers produced and the final number of head-bearing tillers for soft red winter wheat (SRWW) cultivars in the Great Plains (USA) and hard red spring wheat (HRSW) in south-western North Dakota. However, no significant cultivar x planting density interactions (CV x PD) were found for the number of heads  $m^{-2}$  by these authors, which agrees with the results of this study.

Cultivars used in this study are known to differ in tillering ability due to the differences in growth period (see cultivar description, Table 3.6), but these cultivars did not tend to differ in terms of the number of heads  $plant^{-1}$  in normal to high potential growing seasons such as Riverdale 2006, Swellendam 2006 and Caledon (2005 and 2006). However, when crowded in wide rows (300 mm), results obtained at Swellendam in 2005 indicated that the cultivars tested did respond differently to row widths under low rainfall conditions. Under such conditions SST 94 produced more heads  $plant^{-1}$  compared to SST 88 and therefore seemed to be better adapted to these conditions. But this advantage of SST 94 was nullified when competition became too high because cultivar SST 94 produced more heads  $plant^{-1}$  at low planting densities (less crowded), but not at high planting densities. Carr *et al.* (2003) also found that HRSW cultivars in south-western North Dakota did differ with regard to the number of head bearing tillers  $plant^{-1}$ , but did not find any difference in response due to planting density.

Results with regard to the number of kernels  $head^{-1}$  are inconclusive but may be linked with inherent characteristics of the cultivars used. For example no significant cultivar differences or differences in cultivar response due to row widths or planting densities used were found at Caledon (2005) when SST 88, SST 57 and SST 94 were included. In contrast to this, significant differences between cultivars were found at Riversdale and Caledon and a significant interaction between cultivars, planting densities and row widths occurred at Swellendam in 2006 when SST 94 was replaced with SST 015. This interaction is an indication that the cultivars included did differ in response to both row width and planting density in some seasons. Johnson *et al.* (1988) and Carr *et al.* (2003)

also showed differences between SRWW and HRSW cultivars for the number of kernels head<sup>-1</sup>, but found no interactions, as was the case at Swellendam in 2006.

Cultivars differed highly significantly ( $p < 0.001$ ) in thousand kernel mass (TKM) at Caledon in 2005 and at all localities during 2006. For example, SST 88 had a significantly higher TKM than both the other cultivars at Caledon in 2005, but in 2006, SST 015 had the highest TKM at Caledon. These differences are partly due to inherent characteristics of the cultivars, but were also affected by planting density. At Riversdale for example SST 57 showed no response to increasing planting density, while TKM of SST 88 increased when planting density was increased, and the thousand kernel mass of SST 015 decreased from 45 to 40 g when planting density was increased from 100 to 150 target (no.) of plants m<sup>-2</sup> during 2006. Such cultivar responses for spring wheat varieties in Mediterranean environments were also reported by Anderson (1986). If cultivars are grouped together according to characteristics, groups will differ in stability to produce kernel weights within a certain range and some groups will tend to produce larger kernels (higher TKM) than others (Anderson *et al.*, 2004). This was also true for this study with cultivars like SST 88 and SST 015 often producing larger kernels than SST 57 (Table 5.6). Carr *et al.* (2003) reported similar kernel weight differences between HRSW cultivars across contrasting tillage systems in wheat-fallow monoculture systems in the Great Plains and their results were consistent with findings of other authors such as Ciha (1982) and Johnson *et al.* (1988) for SRWW cultivars.

### **Response to row width**

Increasing row width clearly had a negative effect on the number of heads m<sup>-2</sup> at most of the trials in this study (Swellendam in 2005; Riversdale, Swellendam and Caledon in 2006). However, the absence of significant interactions involving row widths (RW x CV, RW x PD or PD x RW x CV) indicated similar responses by cultivars in terms of heads m<sup>-2</sup> when row widths increased at a range of planting densities. Schoonwinkel *et al.* (1991) reported a reduction in heads m<sup>-2</sup> with increasing row width in significant RW x PD interaction during the 1987 season in a study in the Swartland, but a similar response was not found in the 1986 season. The interaction indicated that more heads m<sup>-2</sup> were produced in narrow rows (175 mm) at low planting densities (50-70 kg seed ha<sup>-1</sup>) than in wide rows (350 mm), but that the number of heads m<sup>-2</sup> were similar for both row widths at the highest planting density (100 kg seed ha<sup>-1</sup>). Schoonwinkel *et al.* (1991) indicated that the responses in their study were most likely due to increased inter-plant competition for resources (water and nutrients) which produced smaller plants with fewer tillers. Doyle (1980) also reported a reduction in tillering due to competition for resources with increasing row widths which led to reduced head populations in New South Wales. Similar reductions in head population was also reported by Marshall and Ohm (1987)

and Johnson *et al.* (1988) for SRWW, when row spacing was increased from 100 mm to 200 mm.

The number of heads per plant<sup>-1</sup> was not significantly influenced by increasing row width at any locality except in a RW x CV interaction at Swellendam in 2005 which has been discussed previously under cultivars. Marshall and Ohm (1987) also found reductions in the number of heads plant<sup>-1</sup> when row width was increased in SRWW and ascribed this response to increased inter-plant competition in wider rows.

The number of kernels head<sup>-1</sup> was only influenced significantly by increasing row width at Riversdale 2006 and in the PD x RW x CV interaction (discussed under cultivars). This slight increase in kernels head<sup>-1</sup> at Riversdale in 2006 (from 25.78 to 27.67), does indicate some compensation for the reduced number of heads m<sup>-2</sup> found at this site when row width was increased. A similar response was found by Lafond (1994), who showed compensation for decreased heads m<sup>-2</sup> (caused by increasing row width), by increased numbers of kernels head<sup>-1</sup> for HRSW. Although Schoonwinkel *et al.* (1991) did not present data on the number of kernels head<sup>-1</sup>, grain weight (g head<sup>-1</sup>) was determined in their study. In a significant interaction, it was found that grain weight (g head<sup>-1</sup>) increased slightly, but significantly with increasing row width at low planting densities but not at the high planting density in one out of two seasons. Johnson *et al.* (1988) did not find any significant differences or interactions for SRWW in kernels head<sup>-1</sup> when increasing row width from 100 mm to 200 mm at low or high planting densities.

Thousand kernel mass was influenced significantly by row width only in Riversdale during 2006, and no interactions were found. The increase in kernel weight to compensate for the reduced number of heads m<sup>-2</sup> due to widening row width, was possibly the result of favourable conditions which prevailed during the grain filling stage at this locality. Yunusa *et al.* (1993) also found significant increases in kernel weight as row widths increased at one out of two sites in Western Australia, but in contrast with these findings, Amjad and Anderson (2006) reported a general tendency of increased numbers of small kernels when row width was increased. Johnson *et al.* (1988), did not find significant differences in kernel weight of SRWW when planting density increased in narrow rows, but that kernel weight increased with planting density in wide rows.

### ***Response to planting density***

The number of heads m<sup>-2</sup> was significantly increased in response to increasing planting density at all localities and in all seasons, except at Swellendam in 2005 (for the highest planting density) and at Riversdale in 2006. This increase in number of heads m<sup>-2</sup> can be attributed to the significant increase in the number of seedlings m<sup>-2</sup> due to planting

density treatments applied at all localities (described in Chapter 4). Similar increases in heads  $\text{m}^{-2}$  when planting density is increased was also found for spring wheat by Laubscher (1986), Anderson and Barclay (1991), Schoonwinkel *et al.* (1991) and Lithourgidis *et al.* (2006) in Mediterranean environments and by Lafond (1994) and Carr *et al.* (2003) in Canada and the USA. For winter wheat, similar results were reported by Puckridge and Donald (1967), Johnson *et al.* (1988) as well as Lafond and Gan (1999).

The only trial where the number of heads  $\text{m}^{-2}$  was significantly reduced due to the high planting density of 250 target (no.) of plants  $\text{m}^{-2}$  was at Swellendam in 2005, when very poor growth conditions prevailed due to low rainfall and interplant competition was most probably very severe. In this trial, seedling establishment (number of seedlings  $\text{m}^{-2}$ ) was also negatively affected, especially at the highest planting density which did not differ from the intermediate planting density (Table 4.3), indicating that competition for resources from an early stage, could have played a role in reducing the number of heads  $\text{m}^{-2}$  later in the season.

Although the number of seedlings established differed significantly due the planting density treatments applied at Riversdale in 2006 (Table 4.5), no significant differences in the number of heads  $\text{m}^{-2}$  due to planting density was found in this trial. During this favourable season, tillering was sufficient to ensure that similar numbers of heads  $\text{m}^{-2}$  were produced at all three planting densities, indicating that increased tillering, under certain circumstances (early planting and sufficient water supply), is able to compensate for low plant populations. Similar responses were found by Anderson (1986) in favourable seasons in a similar Mediterranean climate.

The number of heads per plant<sup>-1</sup> was highly significantly reduced as a result of increasing planting density at all localities. No interactions were found, except at Swellendam in 2005 (PD x CV) which has already been discussed under cultivar response. The inverse relationship between plant population and heads plant<sup>-1</sup> was clearly illustrated in the study of Puckridge and Donald (1967) and is due to increased tiller mortality per plant as the plant population increases. This inverse relationship was also responsible for compensation to produce the same number of heads  $\text{m}^{-2}$  at low plant populations for example at Riversdale in 2006 (Table 5.3).

The number of kernels head<sup>-1</sup> was significantly reduced as a result of increasing planting densities at Caledon in 2005, while a PD x RW x CV interaction was found at Swellendam in 2006 (already discussed under cultivar response). The higher number of kernels head<sup>-1</sup> at the lowest planting density may be seen as a compensating response for the lower number of plants and thus also less heads  $\text{m}^{-2}$ . Schoonwinkel *et al.* (1991)



did not show data on the number of kernels head<sup>-1</sup>, but found grain weight (g head<sup>-1</sup>) was similarly reduced with increasing planting density. Lafond (1994) found similar responses in that the number of kernels head<sup>-1</sup> for HRSW was either unaffected or decreased by increasing planting density. This tendency was also clearly illustrated by Puckridge and Donald (1967) for winter wheat planted at a very wide range of planting densities.

Thousand kernel mass decreased significantly as result of an increase in planting density at Caledon in 2006, while a PD x CV interaction was found at Riversdale in 2006 (which has been discussed under cultivar response). A similar decrease with increasing planting densities was shown by Anderson (1986), Anderson and Barclay (1991) as well as Lafond (1994) for HRSW, but Puckridge and Donald (1967) found no significant response in kernel weight for a wide range of planting densities in winter wheat. Carr *et al.* (2003) indicated that kernel weight is seldom affected when planting densities below 136 kg seed ha<sup>-1</sup> are compared. Increases in kernel weight as compensation for a lower number of heads per unit area may occur if relatively cool, wet conditions which will delay leaf senescence were experienced in the latter portion of the grain fill period (Frederick & Bauer, 1999). Such conditions most probably prevailed at Caledon in 2006 because a very long growth period of 181 days from planting to harvesting was recorded.

## **Conclusion**

It is clear from this study that the components of yield, number of heads m<sup>-2</sup>, number of heads plant<sup>-1</sup>, number of kernels head<sup>-1</sup> and kernel weight can be affected by changes in row widths and planting density. However, the responses will depend to a very large extent on climatic factors during the season but also soil factors such as fertility and water holding capacity.

Many of these responses are driven by the competition for resources which increases as row widths increase. It will therefore be important to quantify this competition. The response that raises the most concern is the clear trend of reduction in the number of heads m<sup>-2</sup> as row widths increase. This trend was significant in the data of four out of the five experiments presented. Therefore the risk of reduced number of heads m<sup>-2</sup> due to wide row widths can not be excluded by this study and will occur in most seasons in the Southern Cape.

The second important response is the compensation by increased numbers of heads plant<sup>-1</sup> when planting density is reduced. This explains why similar numbers of heads m<sup>-2</sup> are sometimes observed at different planting densities, for example at Riversdale in

2006. However, this compensation is not always complete and higher head populations were often achieved by increasing planting density.

The variability of other responses and interactions (especially cultivar interactions) found in this study were either due to fierce competition due to unfavourable circumstances such as prevailed at Swellendam in 2005, or responses of compensation, for example increased number of kernels head<sup>-1</sup> or kernel weight which compensated for reduced head population in almost ideal circumstances at Riversdale in 2006. Although important, such responses are highly dependent on availability of resources during the growing season, and will not necessarily occur in average growing conditions.

## CHAPTER 6

### THE INFLUENCE OF PLANTING DENSITY AND ROW WIDTH ON WHEAT IN CONSERVATION TILLAGE SYSTEMS IN THE WESTERN CAPE. PART 3: GRAIN YIELD, GRAIN PROTEIN AND HECTOLITRE MASS IN THE SOUTHERN CAPE REGION

#### Introduction

Grain yield response to planting density is determined by factors such as soil moisture (as determined by rainfall for rain-fed crops), the physical condition of the soil, the ability of the soil to supply nutrients, the growing period available (determined by time of planting and cut-off date of rainfall) and the genetic make-up of the cultivar used (Del Cima *et al.*, 2004). Research in this field clearly indicated that erring to the high side of optimum planting density seldom has a detrimental effect on grain yield of the wheat crop, but erring to the low side could be much more serious by causing a reduced number of heads  $\text{m}^{-2}$  and a subsequent reduction in yield (Anderson *et al.*, 2004).

The rapid adoption of conservation tillage in winter rainfall area since 2000 necessitated changes in planting equipment to suit the requirements of no-till production. With the short optimum planting time available and stony soils, effectiveness, robustness and stubble handling ability of planters became important criteria. This led to the introduction of imported and locally manufactured no-till planters, which make use of 250-300 mm row spacing to enhance the stubble handling ability of these machines.

The main aim of this study was to quantify the yield and quality response of wheat, when the crop was planted in wider rows than conventionally used in the Southern Cape region of the Western Cape. As wider row widths affect the in-row plant density the second objective of this study was to evaluate suitable planting densities to be used with wider row widths as required by conservation tillage systems.

#### Experimental procedure

Grain yield and quality parameters were determined at three localities in the Southern Cape for three seasons. The trial sites and experimental procedures are described in Chapter 3, but a summary of localities, treatments and data collected are given in Table 6.1.

**Table 6.1** Summary of localities, seasons, treatments and data collected at the Southern Cape localities (Part 3)

<b>Locality</b>	<b>Treatments</b>	<b>Data collected</b>
<b>Riversdale</b>	<b>Cultivars:</b>	Grain Yield
	2004 – SST 88, SST 57, SST 94	Grain Protein
	2006 – SST 88, SST 57, SST 015	Hectolitre mass
	<b>Row widths:</b> 250 and 300 mm	
	<b>Planting densities:</b> 100, 150 and 200 target (no.) of plants m <sup>-2</sup>	
<b>Swellendam</b>	<b>Cultivars:</b>	Grain Yield
	2004 – SST 88, SST 57, SST 94	Grain Protein
	2005 – SST 88, SST 94	Hectolitre mass
	2006 – SST 88, SST 57, SST 015	
	<b>Row widths:</b> 250 and 300 mm	
	<b>Planting densities:</b> 150, 200 and 250 target (no.) of plants m <sup>-2</sup>	
<b>Caledon</b>	<b>Cultivars:</b>	Grain Yield
	2004 – SST 88, SST 57, SST 94	Grain Protein
	2005 – SST 88, SST 57, SST 94	Hectolitre mass
	2006 – SST 88, SST 57, SST 015	
	<b>Row widths:</b> 250 and 300 mm	
	<b>Planting densities:</b> 100, 175 and 250 target (no.) of plants m <sup>-2</sup>	

## Results

Pr>F values for differences between treatment means which indicated significant differences in grain yield (ton ha<sup>-1</sup>), grain protein (%) and hectolitre mass (kg hl<sup>-1</sup>) as a result of the treatments applied are given in Table 6.2.

**Table 6.2** Pr>F values, and coefficients of variance of the main effects and interactions in the Southern Cape trials during the period 2004-2005 (p<0.05)

	Riversdale			Swellendam			Caledon		
	Yield	Prot.	HLM	Yield	Prot.	HLM	Yield	Prot.	HLM
<b>2004</b>									
<b>Cultivar</b>	ns	0.019	0.018	ns	ns	ns	<0.001	ns	<0.001
<b>Row width</b>	ns	ns	ns	ns	ns	ns	0.003	ns	ns
<b>RW x CV</b>	ns	ns	ns	ns	ns	ns	ns	ns	ns
<b>Planting Density</b>	ns	ns	ns	ns	ns	ns	ns	ns	ns
<b>PD x CV</b>	ns	0.005	0.042	ns	ns	ns	ns	ns	ns
<b>PD x RW</b>	ns	ns	ns	ns	ns	ns	ns	ns	ns
<b>PD x RW x CV</b>	ns	ns	ns	ns	ns	ns	ns	ns	ns
<b>Cv (%)</b>	<b>20.1</b>	<b>1.8</b>	<b>0.9</b>	<b>11.8</b>	<b>4.4</b>	<b>0.7</b>	<b>13.2</b>	<b>3.9</b>	<b>0.1</b>
<b>Appendix no.</b>	<b>C-1</b>	<b>C-3</b>	<b>C-5</b>	<b>C-7</b>	<b>C-10</b>	<b>C-12</b>	<b>C-15</b>	<b>C-18</b>	<b>C-21</b>
<b>2005</b>									
<b>Cultivar</b>	-	-	-	ns	nd	ns	ns	ns	ns
<b>Row width</b>	-	-	-	ns	nd	ns	ns	ns	ns
<b>RW x CV</b>	-	-	-	ns	nd	ns	ns	ns	ns
<b>Planting Density</b>	-	-	-	ns	nd	0.010	0.002	ns	ns
<b>PD x CV</b>	-	-	-	ns	nd	ns	ns	ns	ns
<b>PD x RW</b>	-	-	-	ns	nd	ns	ns	ns	ns
<b>PD x RW x CV</b>	-	-	-	ns	nd	ns	ns	ns	ns
<b>Cv (%)</b>	-	-	-	<b>19.1</b>	-	<b>2.2</b>	<b>8.1</b>	<b>3.7</b>	<b>0.7</b>
<b>Appendix no.</b>				<b>C-8</b>		<b>C-13</b>	<b>C-16</b>	<b>C-19</b>	<b>C-22</b>
<b>2006</b>									
<b>Cultivar</b>	0.002	0.030	<0.001	<0.001	0.007	<0.001	ns	0.024	ns
<b>Row width</b>	ns	ns	ns	0.003	ns	0.016	0.032	0.001	ns
<b>RW x CV</b>	ns	ns	ns	ns	0.037	0.048	ns	ns	ns
<b>Planting Density</b>	ns	ns	ns	ns	ns	ns	ns	ns	ns
<b>PD x CV</b>	ns	ns	ns	ns	ns	ns	ns	ns	ns
<b>PD x RW</b>	ns	ns	ns	ns	ns	ns	ns	ns	ns
<b>PD x RW x CV</b>	ns	ns	ns	ns	ns	ns	ns	ns	ns
<b>Cv (%)</b>	<b>8.1</b>	<b>4.1</b>	<b>1.0</b>	<b>11.1</b>	<b>2.1</b>	<b>0.7</b>	<b>11.5</b>	<b>3.5</b>	<b>0.9</b>
<b>Appendix no.</b>	<b>C-2</b>	<b>C-4</b>	<b>C-6</b>	<b>C-9</b>	<b>C-11</b>	<b>C-14</b>	<b>C-17</b>	<b>C-20</b>	<b>C-23</b>

Yield = grain yield (ton ha<sup>-1</sup>), Prot.= grain protein (%), HLM = Hectolitre mass (kg hl<sup>-1</sup>), CV=Cultivar, RW=row width, PD=planting density and Cv (%) = the coefficient of variance.nd = not determined, (-) = no data

### **Grain yield**

*During 2004 no significant differences or interactions with regard to grain yield were found at Riversdale (Table 6.2). In 2006, cultivars differed significantly with regard to grain yield, but no significant interactions between cultivars and the factors row width or planting density occurred. At Swellendam no significant differences in grain yield for the factors cultivar, row width or planting density were found in 2004 and 2005 but in 2006, significant differences between cultivars and row widths were found (Table 6.2). At Caledon significant grain yield responses with regard to cultivars were found in 2004. Significant grain yield differences due to changes in row width were found during 2004 and 2006. Planting density influenced grain yield significantly in 2005. At this locality no significant interactions between any of the factors (planting density, row width or cultivars) were found for grain yield.*

High pre-season rainfall (216 mm) at Riverdale in 2004 (Table 3.4) saturated the soil before planting on the 8<sup>th</sup> of May (Table 3.7) and another 64 mm of rain after planting resulted in waterlogged conditions in some parts of the experiment. Crop growth on these areas were affected for the rest of the season and resulted in a very high coefficient of variance (Cv) of 20.1%. No differences with regard to grain yield were found for cultivars, row widths or planting densities in this trial (Table 6.2).

Rainfall received at Riversdale in 2006 (Table 3.4) enabled early planting of the crop (Table 3.7) which resulted in a long growing season without any obvious periods of low rainfall which might result in water stress conditions. Under these conditions, the absence of influence of the factors row width and planting density (and their interactions), was not unexpected. The cultivar SST 88 with the longest growing season of the cultivars used (Table 3.6) was favoured and produced significantly higher yields (4.003 ton ha<sup>-1</sup>) than SST 015 (3.047 ton ha<sup>-1</sup>) and SST 57 (3.036 ton ha<sup>-1</sup>) in 2006 (Figure 6.1). The absence of interaction between the cultivars used and the factors row width and planting density, indicates that the responses of the cultivars to different row widths and planting densities were not different.

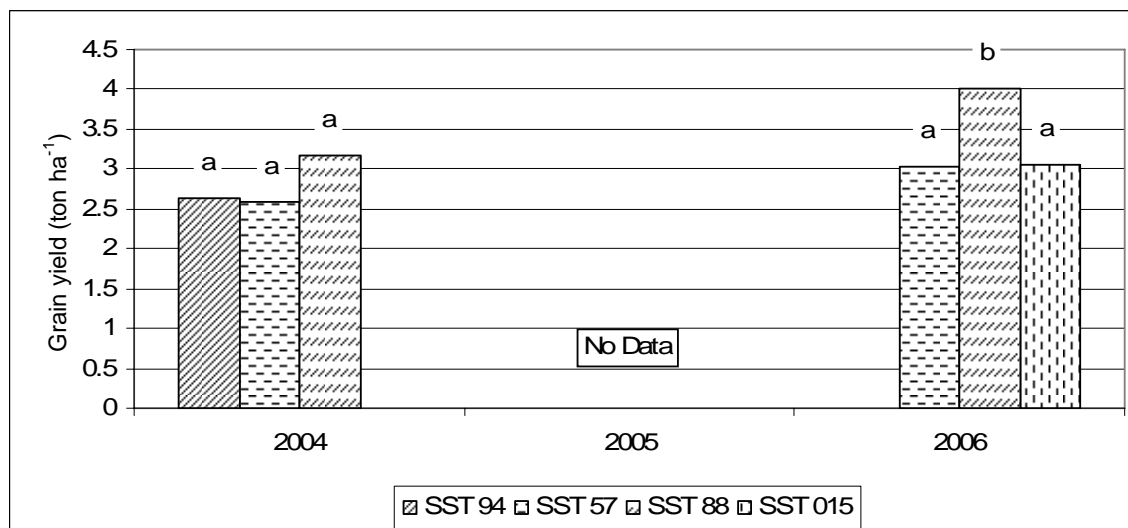

**Figure 6.1** Grain yield (ton ha<sup>-1</sup>) for the different cultivars at Riversdale in 2004 and 2006. LSD<sub>(0.05)</sub> Riversdale = 0.3385.

The 2004 and 2005 seasons in Swellendam, produced very low yield levels due to dry conditions which prevailed throughout both growing seasons (Table 3.4). Very low rainfall during the latter half of the growing season most probably resulted in terminal drought in both seasons, which may have masked any yield responses to cultivars, row widths or planting density treatments (Figure 6.2). A very high coefficient of variance (Cv) of 19.1% in 2005 also indicated that the data should be handled with care.

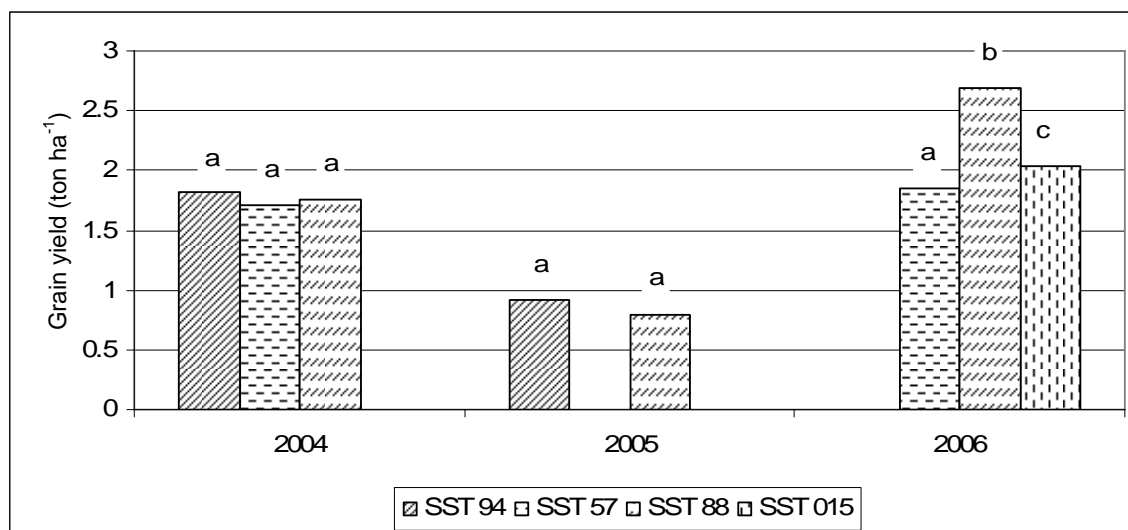

**Figure 6.2** Grain yield (ton ha<sup>-2</sup>) of the cultivars SST 94, SST 57, SST 88 and SST 015 at the Swellendam site 2004-2006. LSD<sub>(0.05)</sub> 2006= 0.0782. Treatment means with the same letter (within a season) do not differ significantly.

Regular precipitation during the period mid-July to August and during October 2006 (Table 3.4), favoured the late maturing SST 88 (grain yield of 2.686 ton ha<sup>-1</sup>), while

SST 015 also yielded significantly more (2.038 ton ha<sup>-1</sup>) than SST 57 (1.852 ton ha<sup>-1</sup>) at the Swellendam locality (Figure 6.2). Grain yields at Caledon in response to cultivars used for the period 2004-2006 are shown in Figure 6.3.

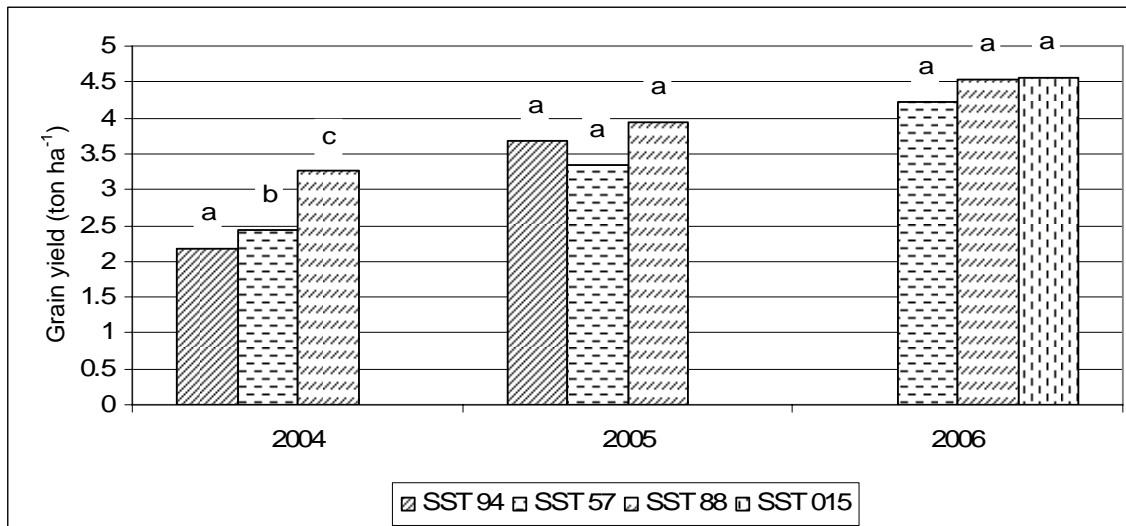

**Figure 6.3** Treatment means for grain yield (ton ha<sup>-1</sup>) of cultivars (SST 94, SST 57, SST 88 and SST 015) used at Caledon from 2004-2006. LSD<sub>(0.05)</sub> 2004 = 0.2413. Treatment means with the same letter (within a season) do not differ significantly.

Figure 6.3 shows that SST 88 yielded significantly more (3.252 ton ha<sup>-1</sup>) than SST 57 (2.434 ton ha<sup>-1</sup>) and SST 94 (2.168 ton ha<sup>-1</sup>) in 2004. Although a fairly dry period was experienced from the end of July to mid September (Table 3.4) high rainfall (123 mm) in October favoured the late maturing cultivar SST 88 (Table 3.6). No significant yield differences were found between cultivars at this locality in 2005 and 2006.

The influence of row width on grain yield at Swellendam in 2006 can be seen in Figure 6.4. A significantly lower grain yield of 2.318 ton ha<sup>-1</sup> (10.9% reduction) was produced when a wide row width (300 mm) was used instead of the narrower 250 mm row width (2.605 kg ha<sup>-1</sup>). Although rainfall seemed sufficient during the 2006 season, a dry period (June to mid-July) could have increased inter-plant competition during the tillering stage and affected crop development negatively. This negative effect of competition was also seen in a reduced number of heads m<sup>-2</sup> (Figure 5.1) and could have contributed to the reduction in grain yield.

At Caledon, significant reduction in grain yield was found with increasing row widths from 250 mm to 300 mm in 2004 and 2006 (Figure 6.5).



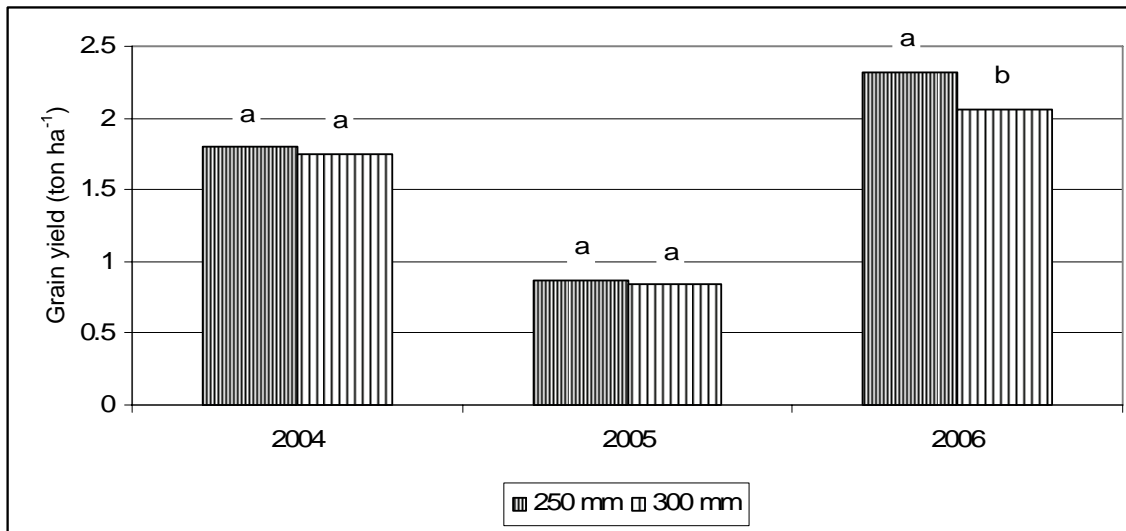

**Figure 6.4** Grain yield (ton ha<sup>-1</sup>) at 250 mm and 300 mm row widths at the Swellendam site from 2004 - 2006. LSD<sub>(0.05)</sub> 2006 = 0.1295. Treatment means with the same letter (within a season) do not differ significantly.

In 2004, grain yield was reduced by 210 kg ha<sup>-1</sup> (7.7%) from 2.722 to 2.514 ton ha<sup>-1</sup> (Figure 6.5). Although grain yields were much higher in 2006 due to rainfall conditions that favour high yields (Table 3.3) a similar percentage reduction (7.1%) was found due to the use of wider row widths. In this trial, a significant reduction in heads m<sup>-2</sup> at the wider row width (Figure 5.1), was found and although number of kernels head<sup>-1</sup> (Figure 5.4) and TKM (Table 5.2) increased with increased row widths, these increases clearly did not compensate for the reduction in heads m<sup>-2</sup>.

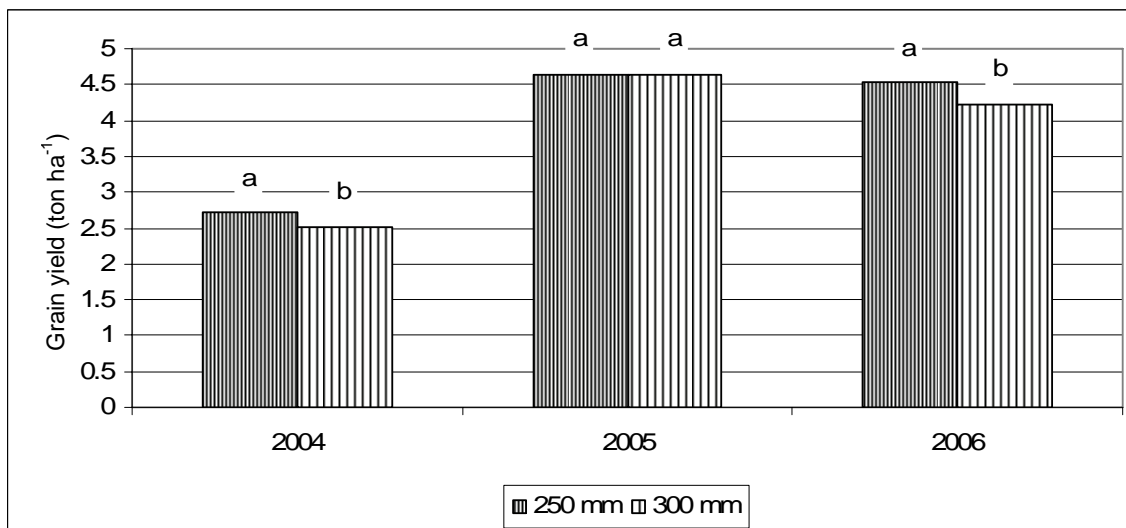

**Figure 6.5** Treatment means for grain yield (ton ha<sup>-1</sup>) at the 250 mm and 300 mm row widths at Caledon from 2004-2006. LSD<sub>(0.05)</sub> 2004 = 0.1060, LSD<sub>(0.05)</sub> 2006 = 0.2837. Treatment means with the same letter (within a season) do not differ significantly.

The only yield response to planting density was found at Caledon during the 2005 season (Figure 6.6) when the lowest planting density treatment (100 target (no). of plants m<sup>-2</sup>) produced a higher grain yield (3.865 ton ha<sup>-1</sup>) compared to the 3.599 and

3.480 ton ha<sup>-1</sup> for the 175 and 250 target (no.) plants m<sup>-2</sup> treatments respectively due to an increased number of kernels head<sup>-1</sup> (Table 5.7) in spite of significantly fewer heads m<sup>-2</sup> than the two higher planting densities (Table 5.3). Similar compensation occurred during 2006 at Caledon, but in that year the reduction in the number of heads m<sup>-2</sup> at the lowest planting density was compensated for by a significant increase in TKM (Chapter 5, Table 5.7) with the result that grain yields did not differ.

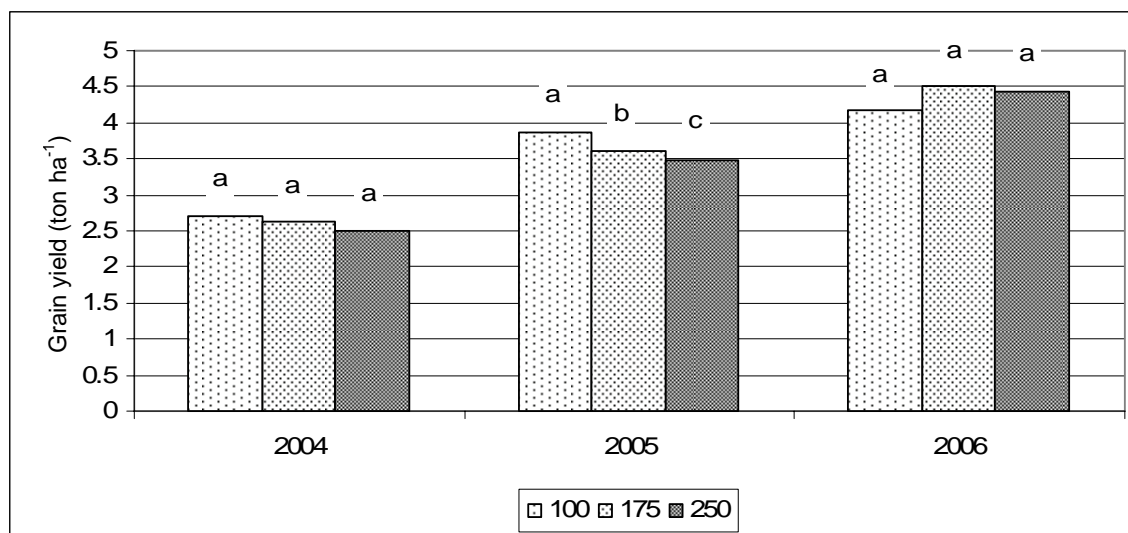

**Figure 6.6** Treatment means for grain yield (ton ha<sup>-1</sup>) for the 100, 175 and 250 target (no.) of plants m<sup>-2</sup> treatments at Caledon from 2004-2006. LSD<sub>(0.05)</sub> 2005 = 0.2045. Treatment means with the same letter (within a season) do not differ significantly.

### **Grain protein (%)**

A significant planting density x cultivar interaction (PD x CV) was found for grain protein (%) at Riversdale in 2004 (Table 6.2), and a significant row width x cultivar (RW x CV) interaction occurred at Swellendam in 2006. Significant differences in grain protein (%) due to cultivars used were measured at Riversdale and Caledon during 2006. Grain protein (%) was significantly affected by different row widths at Caledon during 2006.

The relationship between grain yield and grain protein (%) among cultivars in a fixed environment is frequently negative and the relationship between quantity and quality of protein is strongly influenced by factors such as genetics and environmental conditions (Deckard *et al.*, 1994). Such a negative relationship has been shown for a South African spring wheat cultivar (Gamtoos) by Tolmay *et al.* (1997). It can therefore be expected that when the yield levels of a cultivar are affected by row widths or planting densities, grain protein could be affected accordingly and that cultivars could differ in grain protein (%) produced.

The planting density x cultivar interactions with regards to grain protein (%) at Riversdale in 2004 is shown in Table 6.3.

**Table 6.3** Cultivar and planting density interaction for grain protein and hectolitre mass at Riversdale 2004 and 2006

Cultivar	Grain protein (%)				Hectolitre mass (kg hl <sup>-1</sup> )			
	Planting density (target (no.) of plants m <sup>-2</sup> )				Planting density (target (no.) of plants m <sup>-2</sup> )			
	100	150	200	Mean	100	150	200	Mean
<b>2004</b>								
<b>SST 88</b>	12.27 a	12.11 a	11.83 b	<b>12.07 d</b>	79.37 ab	79.67 a	78.50 bc	<b>79.19 d</b>
<b>SST 94</b>	11.40 c	11.67 b	11.64 bc	<b>11.57 e</b>	77.07 d	77.28 d	77.60 cd	<b>77.32 e</b>
<b>Mean</b>	<b>11.84</b>	<b>11.89</b>	<b>11.74</b>	<b>11.82</b>	<b>78.22</b>	<b>78.49</b>	<b>78.05</b>	<b>78.25</b>
<b>2006</b>								
<b>SST 88</b>	10.73	10.64	10.34	<b>10.57 d</b>	78.67	78.80	78.80	<b>78.76 d</b>
<b>SST 57</b>	11.06	10.90	10.97	<b>10.97 de</b>	75.63	75.87	75.87	<b>75.73 e</b>
<b>SST 015</b>	11.34	11.13	11.48	<b>11.31 e</b>	76.43	76.77	76.70	<b>76.63 f</b>
<b>Mean</b>	<b>11.04</b>	<b>10.89</b>	<b>10.93</b>	<b>10.95</b>	<b>76.91</b>	<b>77.14</b>	<b>77.12</b>	<b>77.06</b>

**2004**

LSD<sub>(0.05)</sub> Cultivar means = 0.2984

LSD<sub>(0.05)</sub> Planting densities means = ns

LSD<sub>(0.05)</sub> CV x PD interaction = 0.2664

LSD<sub>(0.05)</sub> Cultivar means= 1.081

LSD<sub>(0.05)</sub> Planting densities means = ns

LSD<sub>(0.05)</sub> CV x PD interaction = 0.935

**2006**

LSD<sub>(0.05)</sub> Cultivar means = 0.4737

LSD<sub>(0.05)</sub> Planting densities means = ns

LSD<sub>(0.05)</sub> CV x PD interaction = ns

LSD<sub>(0.05)</sub> Cultivar means= 0.7550

LSD<sub>(0.05)</sub> Planting densities means = ns

LSD<sub>(0.05)</sub> CV x PD interaction = ns

Treatment means within interactions followed by the same letter (a-c) do not differ significantly. Treatment means within a column and indicated by bold (cultivars) followed by the same letter (d-f) do not differ significantly.

No consistent trends with regards to the role of planting density could be found in this interaction, but it was clear that cultivars, due to genetic factors, differed significantly. The cultivar SST 88, produced a mean grain protein content of 12.07%, while SST 94 only produced a mean protein content of 11.57%. This difference in grain protein content would have affected the grading of the wheat on the grounds of protein content (ARC-Small Grain Institute, 2007).

At Riversdale in 2006 cultivars differed significantly without interaction for grain protein (Table 6.3). SST 015 had the highest grain protein (11.31%) but not significantly higher than SST 57 (10.97%). However, grain protein (%) of SST 88 (10.57%) which did not differ significantly from SST 57, was significantly lower than that of SST 015.

In 2006 cultivars and row widths affected grain yield significantly at Swellendam and therefore the quality parameters were also affected by these factors (Table 6.2). The row

width x cultivar interactions for grain protein is given in Table 6.4. From this interaction it is clear that cultivars, (therefore genetic differences) had the biggest influence on grain protein (%). Differences between cultivars were however not large enough to have influenced the grading of the wheat (ARC-Small Grain Institute, 2007).

**Table 6.4** Row width x Cultivar interactions for grain protein and hectolitre mass at Swellendam 2006

Cultivar	Grain protein (%)			Hectolitre mass (kg hl <sup>-1</sup> )		
	Row width (mm)			Row width (mm)		
	250	300	Mean	250	300	Mean
<b>SST 88</b>	9.99 a	10.03 a	<b>10.01 f</b>	78.42 a	78.49 a	<b>78.46 f</b>
<b>SST 57</b>	10.46 b	10.78 bc	<b>10.62 g</b>	74.76 b	75.44 c	<b>75.10 g</b>
<b>SST 015</b>	10.79 c	10.74 bc	<b>10.77 g</b>	75.71 c	75.88 c	<b>75.78 g</b>
<b>Mean</b>	<b>10.41</b>	<b>10.52</b>	<b>10.47</b>	<b>76.30 d</b>	<b>76.59 e</b>	<b>76.44</b>

LSD<sub>(0.05)</sub> Cultivar means = 0.3325

LSD<sub>(0.05)</sub> Cultivar means = 0.4077

LSD<sub>(0.05)</sub> Row width = ns

LSD<sub>(0.05)</sub> Row width = 0.2145

LSD<sub>(0.05)</sub> CV x RW interaction = 0.3267

LSD<sub>(0.05)</sub> CV x RW interaction = 0.4203

Treatment means within the interactions followed by the same letter (a-c) do not differ significantly.

Treatment means within a row and indicated by bold (row widths) followed by the same or no letter (d-e), do not differ significantly. Treatment means within a column and indicated by bold (cultivars) followed by the same letter (f-g), do not differ significantly.

Grain protein (%) of the cultivars differed significantly at Caledon during the 2006 season and this was also significantly influenced by row width (Table 6.5). Grain protein (%) of SST 57 (10.94%) and SST 015 (10.84%) were significantly higher (Table 6.5) than that of SST 88 (10.54%). The protein content of SST 57 and SST 015, did not differ significantly. Grain protein increased significantly from 10.66% to 10.90% as row width increased from 250 mm to 300 mm (Table 6.5).

**Table 6.5** Treatment means for (cultivars and row widths) for grain protein (%) at Caledon in 2006

Cultivar	Grain protein (%)		
	Row widths (mm)		
	250	300	Mean
<b>SST 88</b>	10.83	10.71	<b>10.54 a</b>
<b>SST 57</b>	10.91	10.97	<b>10.94 b</b>
<b>SST 015</b>	10.67	11.01	<b>10.84 b</b>
<b>Mean</b>	<b>10.66 a</b>	<b>10.90 b</b>	<b>10.78</b>

LSD<sub>(0.05)</sub> Cultivars = 0.2249

LSD<sub>(0.05)</sub> Row width = 0.1064

LSD<sub>(0.05)</sub> RW X CV = ns

Treatment means within a row and incited by bold (row width) followed by the same letter do not differ significantly. Treatment means within a column and indicated by bold (cultivars) followed by the same letter, do not differ significantly. Treatment means not followed by a letter do not differ significantly.

The influence of row widths on grain protein in this trial can be attributed to significant differences in grain yield measured at the different row widths. These results show that grain protein (%) was primarily influenced by genetic factors associated with different cultivars and secondly by yield levels which differed amongst cultivars due to treatments applied.

### **Hectolitre mass**

*Hectolitre mass (HLM) was influenced by cultivars at Caledon in 2004 and by planting density at Swellendam in 2005, while a significant planting density x cultivar interaction (PD x CV) was found for HLM at Riversdale in 2004 and a significant row width x cultivar (RW x CV) interaction occurred at Swellendam in 2006 (Table 6.2).*

At Caledon in 2004, cultivar SST 88 showed a significantly higher hectolitre mass (80.31 kg hl<sup>-1</sup>) compared to SST 57 (78.36 kg hl<sup>-1</sup>) and SST 94 (78.13 kg hl<sup>-1</sup>) which did not differ significantly from each other (Table 6.6).

Consistent trends with regard to row widths in the RW x CV interaction for HLM at Swellendam 2006 (Table 6.4) were not clear, with cultivars differing significantly and row widths causing slight but significant differences.

**Table 6.6** Treatment means (cultivars and planting densities) for hectolitre mass at Caledon in 2004

Cultivar	Hectolitre mass (kg hl <sup>-1</sup> )			
	Target (no.) of plants m <sup>-2</sup>			
	100	175	250	Mean
<b>SST 88</b>	80.03	80.68	80.23	<b>80.31 a</b>
<b>SST 57</b>	78.21	78.24	78.63	<b>78.36 b</b>
<b>SST 94</b>	78.20	77.91	78.29	<b>78.13 b</b>
<b>Mean</b>	<b>78.81</b>	<b>78.94</b>	<b>79.05</b>	<b>78.93</b>

LSD<sub>(0.05)</sub> Cultivars = 0.470

LSD<sub>(0.05)</sub> Planting density = ns

LSD<sub>(0.05)</sub> PD X CV = ns

Treatment means within a column and indicated by bold (cultivars) followed by the same letter, do not differ significantly. Treatment means not followed by a letter do not differ significantly.

Similarly, no consistent trends with regard to the role of planting density treatments could be identified in the PD x CV interaction for HLM at Riversdale in 2004 (Table 6.3), but it is clear that genetic influences of the cultivars involved (SST 88 and SST 94) had a major influence on this quality parameter. At Swellendam in 2005, hectolitre mass was significantly influenced by planting density treatments; HLM increased significantly from 74.67 kg hl<sup>-1</sup> at the lowest planting density treatment of 150 target of (no.) of plants m<sup>-2</sup> to 77.07 kg hl<sup>-1</sup> at the highest planting density treatment of 200 target (no.) of plants m<sup>-2</sup>

(Table 6.7). Although the difference in mean values for the two cultivars were large, this differences was not significant at the  $p < 0.05$  level.

**Table 6.7** Treatment means (cultivars and planting densities) for hectolitre mass at Swellendam in 2005

Cultivar	Hectolitre Mass (kg hl <sup>-1</sup> )			
	Target (no.) of plants m <sup>-2</sup>			
	100	175	250	Mean
<b>SST 88</b>	76.43	78.56	79.30	<b>78.10</b>
<b>SST 94</b>	72.71	73.39	74.84	<b>73.71</b>
<b>Mean</b>	<b>74.67a</b>	<b>75.97 ab</b>	<b>77.07 b</b>	<b>36.2</b>

LSD<sub>(0.05)</sub> Cultivars = ns

LSD<sub>(0.05)</sub> Planting density = 1.446

LSD<sub>(0.05)</sub> PD X CV = ns

Treatment means and incited by bold (planting density treatments) followed by the same letter (a-b) do not differ significantly.

These results indicate that the quality parameter hectolitre mass was mostly influenced by the cultivars used (genotype) but that the factors row width and planting density could influence this parameter in some cases.

## Discussion

### *Cultivar response*

The late maturing cultivar SST 88 out yielded other cultivars at Riversdale and Swellendam in 2006 as well as Caledon in 2004, in seasons when the crop was established early and sufficient rain late in the season enable a long growing season. When the crop was established fairly late in the season, for example at Caledon in 2005 and 2006, SST 88 did not produce higher yields than other cultivars tested, probably due to the growing season being too short for the cultivar to reach its full potential. Previous studies which included different planting dates (Ciha, 1983; Shackley & Anderson, 1995; Anderson *et al.*, 2004) also observed different cultivar responses to early and late planting. Acevedo *et al.* (1999) emphasized the importance of early planting, especially in Mediterranean environments, in order to escape pre-mature terminal drought and/or the possibility of exposure to high temperatures during grain filling.

In support of studies by Johnson *et al.* (1988) as well as Anderson and Barclay (1991), yield responses of different cultivars were not affected by row widths or planting densities. Several other studies (Briggs & Aytenfisu, 1979; Ciha, 1983; Del Cima *et al.*, 2004; Amjad and Anderson, 2006), found no significant RW x CV or PD x RW x CV interactions in a similar study in the western Australian wheat belt. In contrast with these findings RW x CV interactions was found by Marshall and Ohm (1978) for hard red winter wheat (HRWW).

Similar observations were made by Johnson *et al.* (1988), Anderson and Barclay (1991) as well as Amjad and Anderson (2006) who did their research in Western Australia, but several other authors (Marshall & Ohm, 1978; Briggs & Aytenfisu, 1979; Ciha, 1983; Del Cima *et al.*, 2004) showed that yield responses of different cultivars are indeed affected by row widths and planting densities.

Quality parameters such as kernel protein content and hectolitre mass are often dependant on genetic factors (Slafer *et al.*, 2002) but can be influenced by inter-plant competition and environmental factors because of the effect of these factors on kernel size or weight (Miralles & Slafer, 1999). In this study grain protein percentage and hectolitre mass were directly influenced by genetic factors inherent to the cultivars and indirectly by factors such as row width and planting densities that affected grain yield. At some localities/years, differences between cultivars were affected because of interactions with row widths and planting densities, but results were very inconsistent and trends were not clear.

### ***Response to row width***

The increase of row widths from 250 to 300 mm did not reduce yield significantly in five out of the eight trials (Riversdale 2004, Swellendam 2004, Swellendam 2005, Caledon 2005 and Riversdale 2006). During seasons with low rainfall, such as Swellendam in 2004 and 2005, increased row width seemed to have had little influence on grain yield, probably because of terminal drought which set in at early stages for both narrow and wide row widths. During the opposite scenario when rainfall during critical growth stages and especially during the grain filling stages were sufficient to prevent water stress (Riversdale 2006), the increased number of kernels head<sup>-1</sup> and higher kernel weights (TKM), produced when crops were planted in 300 mm rows, compensated for the reduction of heads m<sup>-2</sup> found with wide row widths to the extent that the influence of the wider row widths on grain yield was not significant. Lafond (1994) also found that the reduced number of heads m<sup>-2</sup> due to wide row width was often counterbalanced by increased number of kernels head<sup>-1</sup> and increased kernel weight.

Grain yields were however reduced when row widths were increased from 250 to 300 mm when dry spells (low rainfall) occurred during critical growth stages such as experienced at Swellendam and Caledon during 2006. Total seasonal rainfall of 271 mm measured at Swellendam and 435 mm measured at Caledon suggested excellent growth conditions. However fairly dry conditions due to low rainfall during September and October when water requirements of the crops was high (especially during mid-October when maximum daily temperatures were above long term averages), prevented

the plants from fully compensating for the reduction in heads  $\text{m}^{-2}$  produced with increased row widths by increased kernels head<sup>-1</sup> or increased kernel weight. Under these conditions grain yield was reduced by 10.9% at Swellendam and by 7.1% at Caledon when row widths were increased. These results suggested that yield reduction due to increasing row widths from 250 mm to 300 mm is highly dependant on climatic and/or soil factors that influence tillering, but also the development of yield components such as kernels head<sup>-1</sup> and kernel weight later in the season. These results concur with early findings by Holliday (1963) who found that competition due to the use of wide row widths can adversely affect plant establishment, head population, the number of heads plant<sup>-1</sup>, the number of kernels head<sup>-1</sup> and kernel weight. Due to the unpredictability of rainfall during these critical development stages in the Mediterranean environment of the Southern Cape, the risk of reduced grain yield due to the use of wide plant rows could not be excluded in this study.

In a recent study in a similar Mediterranean environment in Western Australia, Amjad and Anderson (2006) came to the conclusion that the reductions in grain yield due to wide row spacing is most probably due to the increased concentration of seed and fertiliser in a narrow band, causing fertiliser toxicity, which results in reduced plant establishment and competition with weeds. Although plant establishment in this study was effected by increased row width (Chapter 4) seedling survival was close to 80% in most circumstances, even when wider row widths (300 mm) were used. It is therefore suggested that competition for resources after plant establishment, which leads to reduced head populations, can affect grain yield negatively if circumstances do not remain favourable for compensation to take place.

The absence of interactions involving row widths and planting densities (PD x RW) indicate that the response for grain yield was similar for the range of row widths and of planting densities used in this study. Lafond (1994) also did not report PD x RW interactions for spring wheat, while Johnson *et al.* (1988) and Lafond and Gan (1999) also did not report such interactions in their studies with winter wheat in the Great Plains and Canadian Prairies. In contrast with these findings, Schoonwinkel *et al.* (1991) did report significant PD x RW interactions in both a high and low potential season in the Swartland. Their results indicated significantly higher grain yield when wide row widths (350 mm) were used in combination with low planting densities (50 to 75 kg seed  $\text{ha}^{-1}$ ) in a relatively dry season but no differences occurred between row widths at a high planting density (100 kg seed  $\text{ha}^{-1}$ ). In a more favourable season, the highest yield was found at the narrow row width (175 mm) and a planting density of 75 kg seed  $\text{ha}^{-1}$ . At the highest planting density (100 kg seed  $\text{ha}^{-1}$ ) grain yield between the row widths did not differ significantly. Similar PD x RW interactions were also reported by Marshall and



Ohm, (1987) in their study of 16 soft red winter wheat (SRWW) cultivars in Indiana, USA.

Increasing row widths had very little influence on the quality parameter grain protein and significant differences were found in only two out of the eight trials. In the case of the significant RW x CV interaction at Swellendam 2006, no consistent trends with regards to the role of row width in these interactions could be identified. At Caledon in 2006 the slight increase in grain protein corresponded with a decrease in yield levels as row widths increased. McLeod *et al.* (1996) also concluded that grain protein content was inversely related to growing conditions and nitrogen availability during the season and that grain protein (%) was not greatly affected by row width. HLM was affected by row width in only one out of the eight trials (Swellendam 2006) also in a significant RW x CV interaction, but differences were largely due to genetic differences of cultivars and the effect of row width almost negligible. Small but significant row width effects on HLM were also reported by McLeod *et al.* (1996) in only four out of eleven site-seasons.

### ***Response to planting density***

The planting density treatments applied lead to a wide range of plant populations (number of established seedlings  $\text{m}^{-2}$ ) which ranged from about 100 to 250 plants  $\text{m}^{-2}$  (Chapter 4). Notwithstanding this wide range of established plants grain yield was affected by planting density in only one trial, namely Caledon in 2005 in which case the highest yield was produced with the lowest planting density treatment (100 target (no.) of plants  $\text{m}^{-2}$ ). These results indicate that the crop was able to compensate for reduced planting densities through one or more of the following mechanisms: by increased tillering and tiller survival (producing more heads  $\text{m}^{-2}$  by producing more heads  $\text{plant}^{-1}$ ), producing more kernels  $\text{head}^{-1}$  or increasing kernel weight (Chapter 5). This was in contrast with previous results in this region by Fouche and Schoonwinkel (1991) and Laubscher *et al.* (1991) who indicated that at least 165-175 plants  $\text{m}^{-2}$  are needed to produce optimum grain yields. Research by Smit *et al.* (1991) indicated that grain yield could increase up to a level of 278 established plants  $\text{m}^{-2}$  in a study at Tygerhoek in the Southern Cape region. The use of high planting densities was necessary to ensure sufficient head populations, especially in seasons when tillering was restricted due to soil and/or climatic conditions in the conventional cropping system used at the time.

In these systems, compensation mostly occurred early in the growing season if conditions remained favourable during the tillering stage. The introduction of conservation systems (conservation tillage and crop rotation) often improve growing conditions during and after crop establishment through improved soil water conservation which contributes to the crop being established earlier and improves survival percentage

(Chapter 4). Early planting extends the length of the growing season (Baker *et al.*, 1996), while improved soil structure and fertility (Kirkegaard, 1995; Peiretti, 2007) also contributes to enhanced plant growth, tillering and tiller survival. These improved growing conditions also increase the possibility of compensation later in the season (Satorre, 1999) by increased kernels head<sup>-1</sup> (around anthesis) and increased kernel weight (during the grain filling stage). Lower planting densities than used in the conventional cropping systems, can therefore be used successfully within conservation tillage and crop rotation systems in this region.

Grain protein (%) was effected by planting density in only one instance when it was involved in a significant interaction with cultivars (PD x CV) at Riversdale in 2004, but no consistent trend with regards to the role of planting density could be found. McLeod *et al.* (1996) also found that in general, grain protein was not affected by planting density. HLM was only influenced significantly in two out of the eight trials, in an interaction with cultivars (PD x CV) at Riversdale in 2004 and without interaction at Swellendam in 2005. Although the interaction at Riversdale was significant, cultivar differences had an overriding effect. Hectolitre mass increased significantly with increased planting density at Swellendam in 2005, which agrees with the findings of McLeod *et al.* (1996) who reported that test weights (HLM) sometimes increase with increasing planting density.

## **Conclusion**

In the Southern Cape the late maturing cultivar, SST 88, out yielded the other cultivars in seasons with extended growing periods due to early planting, while yields during shorter growing seasons were not lower than that of other cultivars tested. Late maturing cultivars therefore seem to have the ability to take advantage in longer growing seasons made possible by no-till planting because no time is needed for seedbed preparations.

The possibility of a reduction in grain yield due to the use of wide row widths could not be excluded from results of this study. Although grain yield reduction may generally be small, significant losses may occur in some seasons due to the reduction of heads m<sup>-2</sup> with increases in row width. To compensate for this reduction in heads m<sup>-2</sup>, increases in kernels head<sup>-1</sup> and/or kernel weight are needed. These yield components develop during the middle and late phases of the growing season when the availability of adequate soil moisture may be problematic. For this reason row widths should remain as narrow as practically possible to minimize the risk of possible yield losses. Requirements for efficient crop residue (stubble) handling ability in these conservation tillage systems should however be met.

It can be concluded that the Southern Cape region is not very sensitive to the use of lower planting densities when the no-till planting method is used in conjunction with crop rotation. Although these results indicate that planting densities could be drastically reduced from the current recommendation for use in conventional cropping systems (100 to 130 kg seed ha<sup>-1</sup>) in most seasons, some safety margin should be included in recommendations to ensure sufficient plant stands in seasons when tillering is restricted or seedling survival is reduced. More information on a greater variety of cultivars tested over multiple seasons at wider range of planting densities (with smaller increments) will be helpful to determine optimum planting density for this region more accurately. Lafond (1994) emphasized the importance of maintaining adequate plant populations because inadequate plant stands can never be fully compensated for by increased tillering.

Differences found with regard to the quality parameters, grain protein (%) and hectolitre mass in this study, were to a very large extent the result of different genotypic variation. Although cultivar responses were affected by increased row widths or planting densities, these effects were mostly negligible and would not have had a significant influence on how the grain would have been graded.

## CHAPTER 7

### THE INFLUENCE OF PLANTING DENSITY AND ROW WIDTH ON WHEAT IN CONSERVATION TILLAGE SYSTEMS IN THE WESTERN CAPE. PART 4: YIELD COMPONENTS IN THE SWARTLAND

#### Introduction

Competition for resources (water, nutrition and light) between plants in a crop stand, can be kept to the minimum if plants are arranged in a grid-like fashion or planted in very narrow plant rows (Holliday, 1963; Satorre, 1999). High planting densities can be used with such arrangements to increase the number of heads per unit area to cater for possible low survival rates (Laubscher, 1986; Agenbag, 1992). As row widths are increased when planters are used, individual plants are placed in closer proximity to each other, crowding them together and increasing competition between them. Competition for resources results in shorter plants that tiller less and produce fewer heads  $\text{m}^{-2}$ , one of the most important components of yield (Schoonwinkel *et al.*, 1991).

In conventional planting methods narrow row widths of 175 – 180 mm could be used to minimise competition, but in conservation tillage systems where stubble is retained, wide plant rows (usually 250-300 mm) are needed to ensure sufficient stubble flow through the planter and prevent the stubble from packing during the planting process (Giumelli *et al.*, 2002). In this chapter, the influence of the use of wide row widths in combination with different planting densities and cultivars on the components of yield (the number of heads  $\text{m}^{-2}$ , the number of heads  $\text{plant}^{-1}$ , the number kernels  $\text{head}^{-1}$  and kernel weight) in the Swartland region will be discussed.

#### Experimental procedure

The experimental procedure is described in Chapter 3, but a summary of localities, treatments and data collected (to be discussed in this Chapter) is given in Table 7.1.

**Table 7.1** Summary of localities, seasons, treatments and data collected at the Swartland localities

Locality	Treatments	Data collected
<b>Moorreesburg</b>	<b>Cultivars:</b>	Heads m <sup>-2</sup>
	2005 – SST 88, SST 94	Heads plant <sup>-1</sup>
	2006 – SST 88, SST 015	Kernels head <sup>-1</sup>
	<b>Row widths:</b>	Kernel weight (TKM)
	250, 300 and 350 mm	
<b>Hopefield</b>	<b>Planting densities:</b>	
	100, 175 and 250 target (no.) of plants m <sup>-2</sup>	
	<b>Cultivars:</b>	Heads m <sup>-2</sup>
	2005 – SST 88, SST 94	Heads plant <sup>-1</sup>
	2006 – SST 88, SST 015	Kernels head <sup>-1</sup>
	<b>Row widths:</b>	Kernel weight (TKM)
	250, 300 and 350 mm	
	<b>Planting densities:</b>	
	100, 175 and 250 target (no.) of plants m <sup>-2</sup>	

## Results

Number of heads m<sup>-2</sup>, number of heads plant<sup>-1</sup>, the number of kernels head<sup>-1</sup> and kernel weight at different localities and seasons were significantly affected as a result of the treatments applied (Table 7.2).

### ***The number of heads m<sup>-2</sup>***

*The number of heads m<sup>-2</sup> was significantly influenced as a result of the different cultivars used at Moorreesburg in 2005, but not at any of the other localities or in any other experimental season. No interactions between cultivars and any of the other treatments (row widths and planting densities) were found (Table 7.2). The number of heads m<sup>-2</sup> was also influenced by row width with significant differences at both Moorreesburg and Hopefield in 2005 and 2006 (Table 7.2), while planting density had a significant effect on the number of heads m<sup>-2</sup> at both localities (Moorreesburg and Hopefield) in 2006. No interactions between the factors row width and planting density were however found.*

**Table 7.2** Pr >F values and coefficients of variance of the main effects and interactions for heads m<sup>-2</sup>, heads plant<sup>-1</sup>, kernels head<sup>-1</sup> and kernel weight in the Swartland trials during 2005 and 2006 (p<0.05)

	2005		2006	
	Moorreesburg	Hopefield	Moorreesburg	Hopefield
<b>Heads m<sup>-2</sup></b>				
Cultivar	0.004	ns	ns	ns
Row width	<0.001	0.002	0.001	<0.001
RW x CV	ns	ns	ns	ns
Planting Density	ns	ns	<0.001	0.017
PD x CV	ns	ns	ns	ns
PD x RW	ns	ns	ns	ns
PD x RW x CV	ns	ns	ns	ns
Cv (%)	<b>14.8</b>	<b>19.2</b>	<b>8.2</b>	<b>7.1</b>
Appendix no.	<b>D-1</b>	<b>D-5</b>	<b>D-9</b>	<b>D-13</b>
<b>Heads plant<sup>-1</sup></b>				
Cultivar	ns	ns	ns	ns
Row width	0.013	0.046	0.012	0.005
RW x CV	ns	ns	ns	ns
Planting Density	<0.001	<0.001	<0.001	<0.001
PD x CV	ns	ns	ns	ns
PD x RW	ns	ns	ns	ns
PD x RW x CV	ns	ns	ns	ns
Cv (%)	<b>18.0</b>	<b>21.2</b>	<b>8.6</b>	<b>11.3</b>
Appendix no.	<b>D-2</b>	<b>D-6</b>	<b>D-10</b>	<b>D-14</b>
<b>Kernels head<sup>-1</sup></b>				
Cultivar	0.007	0.042	ns	ns
Row width	ns	ns	0.007	ns
RW x CV	ns	ns	ns	ns
Planting Density	ns	ns	ns	0.016
PD x CV	ns	ns	ns	ns
PD x RW	ns	ns	ns	ns
PD x RW x CV	ns	ns	ns	ns
Cv (%)	<b>20.3</b>	<b>25.8</b>	<b>12.3</b>	<b>14.6</b>
Appendix no.	<b>D-3</b>	<b>D-7</b>	<b>D-11</b>	<b>D-15</b>
<b>Kernel weight (g 1000 kernels<sup>-1</sup>)</b>				
Cultivar	ns	ns	ns	ns
Row width	ns	ns	ns	ns
RW x CV	ns	ns	ns	ns
Planting Density	ns	ns	0.024	ns
PD x CV	ns	ns	ns	ns
PD x RW	ns	ns	ns	ns
PD x RW x CV	ns	ns	ns	ns
Cv (%)	<b>5.2</b>	<b>14.6</b>	<b>5.2</b>	<b>5.9</b>
	<b>D-4</b>	<b>D-8</b>	<b>D-12</b>	<b>D-16</b>

CV=Cultivar, RW=row width, PD=planting density and Cv (%) = the coefficient of variance

The cultivar SST 94 produced significantly more heads  $m^{-2}$  (303) compared to SST 88 (264) at Moorreesburg in 2005 (Figure 7.1), but not in 2006 (Table 7.2). These lower numbers recorded for SST 88 in 2005 might be the result of a fairly late planting date of 25 May (Table 3.7) which was near the end of the recommended planting time for this area, together with a fairly dry spell in July during which only 24 mm was received (Table 3.5).

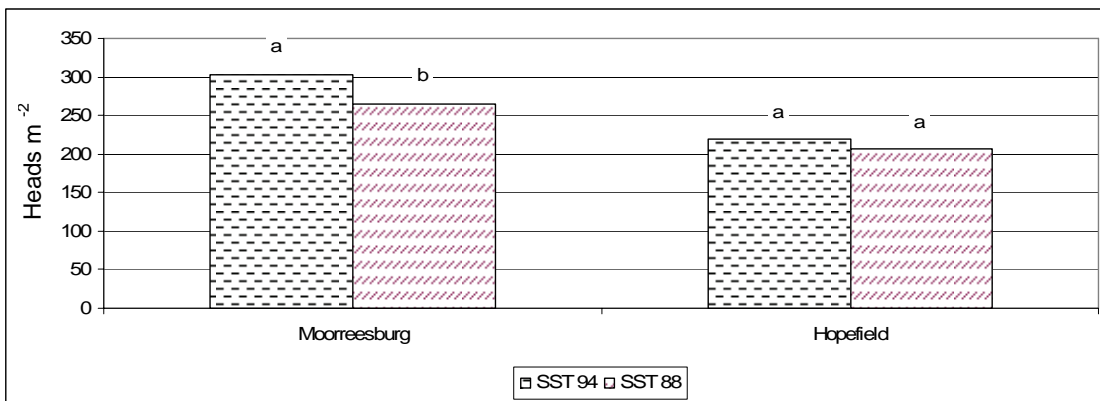

**Figure 7.1** Cultivar differences in the number of heads  $m^{-2}$  at the Swartland localities in 2005.  $LSD_{(0.05)}$  Moorreesburg 2005 = 10.5.

These conditions could have a larger negative effect on tillering and/or tiller survival of SST 88 because of its longer growing period compared to SST 94. Although similar conditions prevailed at Hopefield during 2005, no significant differences were found between cultivars and the average number of heads  $m^{-2}$  (214) was less than at Moorreesburg (283), possibly due to the larger effect such a low rainfall period could have had on the sandy soils of Hopefield which dry out quickly due to its low water holding capacity.

The number of heads  $m^{-2}$  was significantly reduced with increasing row widths at both localities in the Swartland during 2005 and 2006 (Figure 7.2). In 2005 a significantly higher number of heads  $m^{-2}$  was produced with 250 mm row widths compared to 350 mm row widths, but not higher than the number produced with 300 mm row widths at both localities. In 2006 the number of heads  $m^{-2}$  was significantly reduced at both localities with increases in row width from 250 mm to 300 mm and from 300 mm to 350 mm.

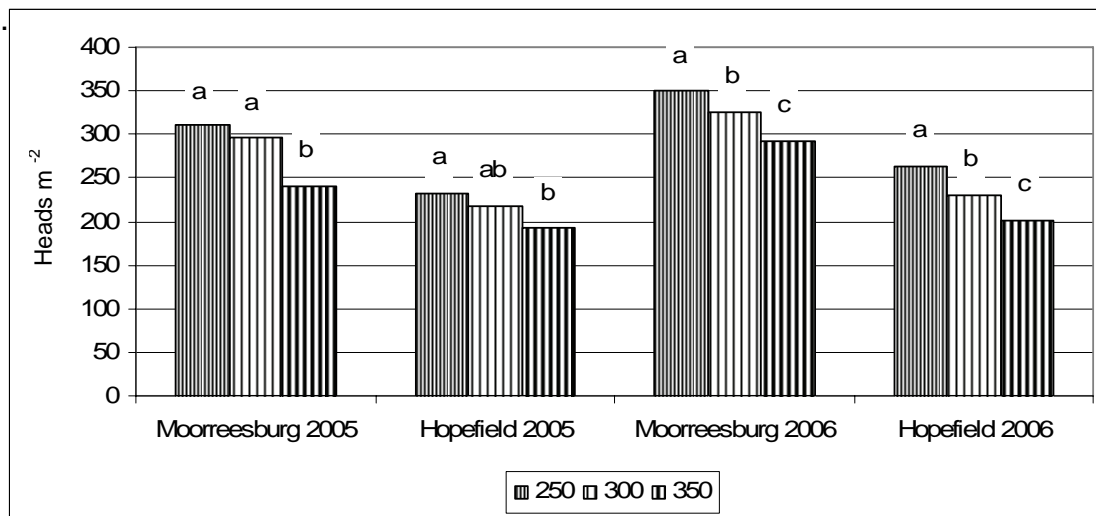

**Figure 7.2** Number of heads  $m^{-2}$  as influenced by row width (250, 300 and 350 mm) in the Swartland during 2005 and 2006. Row widths within a season and locality did not differ significantly if followed by the same letter ( $p < 0.05$ ).  $LSD_{(0.05)}$  Moorreesburg 2005 = 22.14,  $LSD_{(0.05)}$  Moorreesburg 2006 = 22.14,  $LSD_{(0.05)}$  Hopefield 2005 = 25.87,  $LSD_{(0.05)}$  Hopefield 2006 = 16.65.

The number of heads  $m^{-2}$  was not significantly influenced by planting density at Moorreesburg or Hopefield in 2005 although fairly large differences in these numbers were recorded (Table 7.3). During 2006, when the heads were counted in the plots during the growing period, coefficients of variance values were lower and significant differences were found. At Moorreesburg the number of heads  $m^{-2}$  increased from 301 to 330 when planting density increased from 100 to 175 target (no.) of plants  $m^{-2}$  (Table 7.3), but further increases in the planting density to 250 target (no.) of plants  $m^{-2}$  did not have a significant effect.

At Hopefield (Table 7.3), the number of heads  $m^{-2}$  increased from 223 to 240 heads  $m^{-2}$ , as planting density increased from 100 to 250 target (no.) of plants  $m^{-2}$ , but no differences were recorded when planting density was increased from 100 to the 175 or from the 175 to the 250 target (no.) of plants  $m^{-2}$  treatment. These results indicated that planting densities of more than 175 target (no.) of plants  $m^{-2}$  did not result in significant increases in the number of heads  $m^{-2}$  during 2006.



**Table 7.3** The influence of target planting density on heads m<sup>-2</sup> and heads plant<sup>-1</sup> at Moorreesburg and Hopefield for the 2005 and 2006 seasons

Planting density (target (no.) of plants m <sup>-2</sup> )	2005		2006	
	Heads m <sup>-2</sup>	Heads plant <sup>-1</sup>	Heads m <sup>-2</sup>	Heads plant <sup>-1</sup>
<b>Moorreesburg</b>				
100	269	2.4 a	301 a	2.5 a
175	281	1.5 b	330 b	1.7 b
250	299	1.2 c	340 b	1.2 c
<b>Average</b>	<b>283</b>	<b>1.77</b>	<b>324</b>	<b>1.81</b>
<b>LSD</b> (0.05)	<b>ns</b>	<b>0.2122</b>	<b>18.2</b>	<b>0.1067</b>
<b>Hopefield</b>				
100	208	2.0 a	223 a	2.0 a
175	206	1.1 b	232 ab	1.2 b
250	227	0.9 c	240 b	1.0 c
<b>Average</b>	<b>214</b>	<b>1.35</b>	<b>232</b>	<b>1.38</b>
<b>LSD</b> (0.05)	<b>ns</b>	<b>0.1961</b>	<b>11.33</b>	<b>0.1074</b>

Means within each column followed by the same letter are not significantly different from each other at  $p < 0.05$ .

### ***The number of heads plant<sup>-1</sup>***

*The number of heads plant<sup>-1</sup> was significantly influenced by increasing row width and planting densities at both localities in 2005 and 2006 (Table 7.2). No differences due to cultivars or interactions between cultivars, row widths or planting densities occurred.*

No significant differences ( $p > 0.05$ ) in the number of heads plant<sup>-1</sup> were found between cultivars used in this study, indicating that the numbers of heads plant<sup>-1</sup> were to a larger extent affected by environmental conditions than genetic differences due to the cultivars used.

The number of heads plant<sup>-1</sup> at Moorreesburg decreased significantly (from 1.8 to 1.5) as row widths increased from 250 mm to 350 mm in 2005, but not when rows were increased from 250 to 300 mm (Figure 7.3). At Hopefield, the number of heads plant<sup>-1</sup> decreased from 1.4 to 1.2 with an increase in row width from 250 to 350 mm, but the 300 mm row width did not differ significantly from either the 250 or the 350 mm row widths. Similar responses were found at both localities in the 2006 season, with a significant reduction in the number of heads plant<sup>-1</sup> when the row width was increased from 300 to 350 mm, but not from 250 to 300 mm.

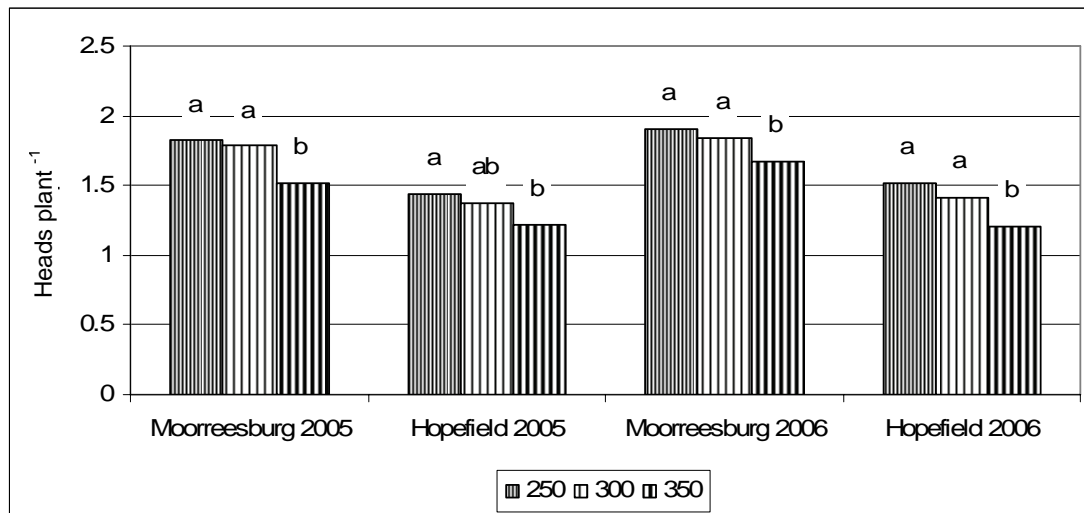

**Figure 7.3** Number of heads plant<sup>-1</sup> as influenced by row width in the Swartland 2005 and 2006. Row widths within a season and locality did not differ significantly if followed by the same letter ( $p < 0.05$ ).  $LSD_{(0.05)}$  Moorreesburg 2005 = 0.2040,  $LSD_{(0.05)}$  Hopefield 2005 = 0.1697,  $LSD_{(0.05)}$  Moorreesburg 2006 = 0.1429,  $LSD_{(0.05)}$  Hopefield 2006 = 0.1504.

These results clearly explain the reduction in the numbers of heads m<sup>-2</sup> due to increased competition for resources as crowding increases at wider row widths. With fewer heads plant<sup>-1</sup> produced at the wider row widths, the head population per unit area also decreased.

The number of heads plant<sup>-1</sup> decreased highly significantly as planting density increased at both localities in 2005 and 2006 (Table 7.3). At Moorreesburg, the number of heads plant<sup>-1</sup> decreased from 2.4 to 1.2 in 2005 and from 2.5 to 1.2 in 2006 with an increase in planting density from the 100 to 250 target (no.) of plants m<sup>-2</sup> treatment. Although a similar response was shown at Hopefield (Table 7.3), lower numbers of heads plant<sup>-1</sup> were produced at this locality, with only 2.0 heads plant<sup>-1</sup> at the lowest planting density of 100 target (no.) of plants m<sup>-2</sup> in both seasons compared to 0.9 and 1.0 heads plant<sup>-1</sup> produced at the highest planting density of 250 target (no.) of plants m<sup>-2</sup>. This is an indication that the potential to produce high numbers of heads plant<sup>-1</sup> and heads per unit area is lower at this locality, most possibly due to sandy infertile soils with low water holding capacity.

### **The number of kernels head<sup>-1</sup>**

Cultivars differed significantly with regard to the number of kernels head<sup>-1</sup> at both localities in 2005 (Table 7.2) and row width significantly influenced the number of kernels head<sup>-1</sup> at Moorreesburg in 2006. The number of kernels head<sup>-1</sup> was also significantly influenced by planting density at Hopefield in 2006. No interactions between cultivars and the other factors in this study were found.

Cultivars, differed significantly with regard to number of kernels head<sup>-1</sup> at both localities in 2005 with SST 94 producing on average 8.3 kernels head<sup>-1</sup> more than SST 88 at Moorreesburg in 2005 and 8.1 kernels head<sup>-1</sup> more than SST 88 at Hopefield (Figure 7.4).

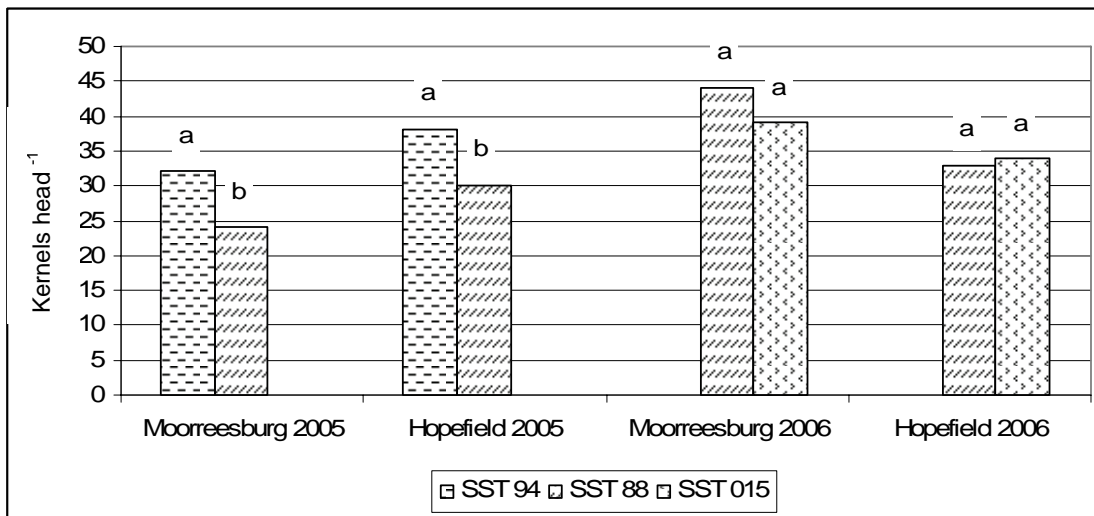
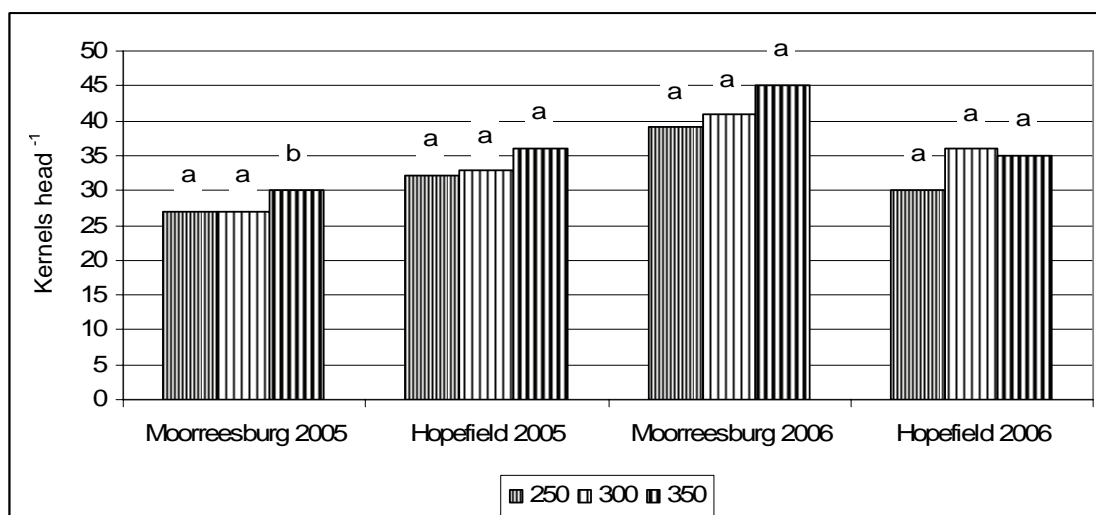

**Figure 7.4** Number of kernels head<sup>-1</sup> of cultivars in the Swartland in 2005 and 2006. Cultivars within a season and locality did not differ significantly if followed by the same letter ( $p < 0.05$ ).

LSD<sub>(0.05)</sub> Moorreesburg 2005 = 2.921; LSD<sub>(0.05)</sub> Hopefield 2005 = 7.41.

In 2006, cultivars SST 88 and SST 015 were used at both localities and no differences in kernels head<sup>-1</sup> were shown (Figure 7.4).

In 2005, 26.9 kernels head<sup>-1</sup> were produced at both the 250 and 300 mm row widths at Moorreesburg compared to 30.2 at the 350 mm row width (Figure 7.5). Although similar trends were shown for Hopefield in 2005 and Moorreesburg in 2006, responses were not significant ( $p > 0.05$ ).



**Figure 7.5** Number of kernels head<sup>-1</sup> as influenced by row width in the Swartland 2005 and 2006. Row widths within a season and locality did not differ significantly if followed by the same letter ( $p < 0.05$ ).  $LSD_{(0.05)}$  Moorreesburg 2005 = 3.049.

The tendency of increased number of kernels head<sup>-1</sup> with increases in row width, indicated that plants compensated for the reduced number of heads plant<sup>-1</sup> measured with increasing row widths.

With the exception of the trial at Hopefield in 2006, the number of kernels head<sup>-1</sup> was not significantly affected ( $p > 0.05$ ) by an increase in planting densities (Figure 7.6).

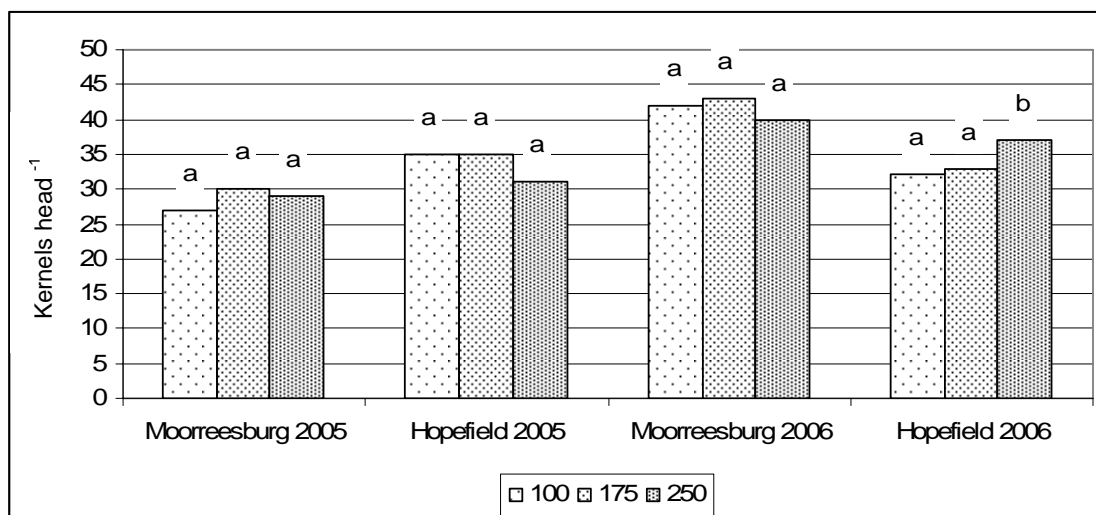

**Figure 7.6** The number of kernels head<sup>-1</sup> as influenced by planting density (100, 175, 250 target (no.) of plants m<sup>-2</sup>) in the Swartland 2005-2006. Planting densities within a season and locality did not differ significantly if followed by the same letter ( $p < 0.05$ ).  $LSD_{(0.05)}$  Hopefield 2006 = 3.406.

At this locality 31.6 and 32.8 kernels head<sup>-1</sup> were produced with the 100 and 175 target (no.) of plants m<sup>-2</sup> treatments respectively compared to 36.6 kernels head<sup>-1</sup> produced by

the 250 target (no.) plants m<sup>-2</sup> treatment. The increase in kernels head<sup>-1</sup> with increasing planting densities might have been in response to the reduced number of heads plant<sup>-1</sup> measured at the highest planting density treatment and favourable growth conditions before and after anthesis (mid-September to early October 2006) due to a total of 30 mm rain (Table 3.5). The same response was however not seen at Moorreesburg which experienced even more rain (52 mm) during this time.

### Thousand Kernel Mass

Kernel weight, measured by thousand kernel mass (TKM) in gram, was significantly influenced by planting density at Moorreesburg in 2006 only (Table 7.2). No differences due to the cultivars used, row widths tested or interactions between the factors cultivar, row width or planting density were found at any locality during the experimental period.

On average larger kernels (higher TKM) were produced in 2006 (40 g at Moorreesburg and 39 g at Hopefield) compared to 2005 (27 g at Moorreesburg and 30 g at Hopefield), because of higher post-anthesis (September-October) rainfall in 2006 (Table 3.5). Treatment responses tended to be larger in 2006 and significant differences due to planting density treatments applied were shown at Moorreesburg in 2006 (Figure 7.7). TKM with the lowest planting density (100 target (no.) of plants m<sup>-2</sup>) was significantly higher (41 g) than at the highest planting density (250 target (no.) of plants m<sup>-2</sup>) (39 g), but not different from the 175 target (no.) of plants m<sup>-2</sup> (40 g).

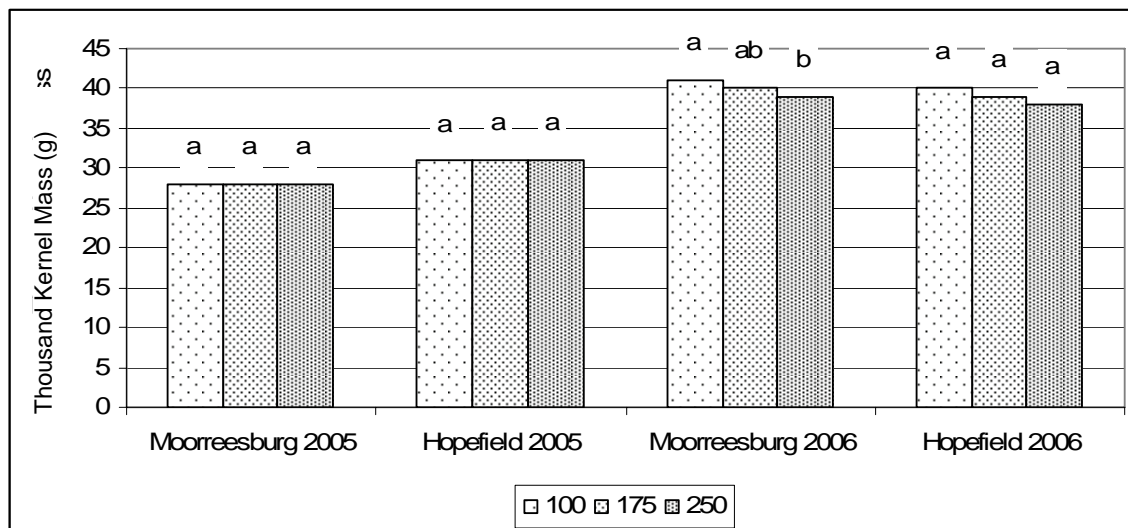

**Figure 7.7** Thousand kernel mass as influenced by planting density (100, 175 and 250 target (no.) of plants m<sup>-2</sup>) in the Swartland 2005-2006. Planting densities within a season and locality did not differ significantly if followed by the same letter ( $p < 0.05$ ). LSD<sub>(0.05)</sub> Moorreesburg 2006 = 1.412.

## Discussion

### ***Cultivar response***

Cultivars (CV) tested in the Swartland study differed with regard to the number of heads  $m^{-2}$  in only one of four experiments conducted (Moorreesburg 2005). During this year, the growing period was shortened due to a fairly late planting date (towards the end of May) and low rainfall (Table 3.5). These conditions could have restricted tillering and would have been better suited to a cultivar with a short growing period like SST 94 compared to a late maturing cultivar such as SST 88. These results were in contrast with results from the Southern Cape region where no cultivar differences in this regard were found, most probably due to earlier planting (first two weeks in May) and thus a longer growing period in the Southern Cape. Both Anderson (1986) and Anderson and Barclay (1991) reported cultivar differences with regard to the number of heads  $m^{-2}$  of spring wheat cultivars in Western Australia, as did Johnson *et al.* (1988) for soft red winter wheat (SRWW) in south-western Dakota and Carr *et al.* (2003) for hard red spring wheat (HRSW) in the Great Plains. The lack of interactions between row widths (RW) and cultivars (RW x CV) and planting densities (PD) and cultivars (PD x CV) indicated that cultivars reacted similarly to increases in row widths and planting densities. Similarly, no such interactions were found by Anderson (1986), Johnson *et al.* (1988), Anderson and Barclay (1991) or Carr *et al.* (2003) in their studies.

The number of heads  $plant^{-1}$  did not differ for cultivars at any of the four trials in the Swartland indicating that differences in the number of heads  $m^{-2}$  found in 2005 at Moorreesburg must be due to differences in plant population (emergence and/or plant survival). Because such differences are most possibly the result of growth conditions, these results suggested that environmental, rather than genetic factors determined how many heads  $plant^{-1}$  remained at the end of the season. No interactions (RW x CV or PD x CV) were found, indicating that cultivars responded similarly to increases in row width and planting density. A study by Carr *et al.* (2003) indicated that HRSW cultivars differed in the number of head bearing tillers produced by each plant, but did not report any PD x CV interactions.

The number of kernels  $head^{-1}$  differed significantly between cultivars at both localities in 2005 when the cultivars SST 94 and SST 88 were used. The low rainfall received at both localities in September and October (Table 3.5) in combination with different growing periods of these cultivars (10-20 days from emergence to anthesis (Table 3.6), could have caused the difference in the number of kernels  $head^{-1}$  observed. Such cultivar differences in kernels  $head^{-1}$  were also found for SRWW in south-western Dakota (Johnson *et al.*, 1988) and HRSW cultivars in the Great Plains (Carr *et al.*,

2003). No cultivar differences for the number of kernels head<sup>-1</sup> were found in 2006 when SST 94 was replaced by SST 015. These results differ from results in the Southern Cape study (Chapter 5) when SST 015 produced consistently fewer kernels head<sup>-1</sup> than the cultivar SST 88.

Cultivars often differ in kernel weight as it is linked to kernel size, which is a cultivar characteristic (Anderson *et al.*, 2004). However, cultivars did not differ significantly in kernel weight in this study, as was the case in the Southern Cape (Chapter 5). The mean TKM of cultivars was very low in 2005, indicating that the low rainfall conditions during the grain filling period (mid-October to early November, Table 3.5) restricted grain fill, which could have had an overriding effect over the genetic differences between cultivars. However, no significant differences between the cultivars SST 88 and SST 015 were found during the 2006 season when higher post-anthesis rainfall during September and October (Table 3.5) supported grain filling. The lack of interactions (PD x CV, RW x CV or PD x RW X CV) suggested that the cultivars tested did not respond differently to growing conditions created by these factors.

### ***Response to row width***

The number of heads m<sup>-2</sup> was reduced when row widths were increased in all trials done during 2005 and 2006 in the Swartland. During 2005, (a growing season with a lower production potential due to lower in-season rainfall and especially low rainfall during July, Table 3.5) differences were not significant when row widths were increased from 250 mm to 300 mm, but only became significant when row widths were increased to 350 mm. But, significant differences were found with every increase in row width from 250 mm during 2006 when the yield potential was assumed higher due to a higher in-season rainfall. These results agree with the results of a study in the Swartland by Schoonwinkel *et al.* (1991) who also found no significant differences in a low potential season when row widths increased from 175 to 350 mm, but significant differences in a high potential season. Similar reductions in the number of heads m<sup>-2</sup> due to increased row widths were reported in various other studies including winter wheat cultivars (Holliday, 1963; Marshall & Ohm, 1987; Johnson *et al.*, 1988). In all of these studies, increased competition for limited resources due to crowding of plants in the plant row are given as an explanation for this response. Such inter-plant competition can reduce tillering early in the season but also affects the survival of tillers that will produce heads (Satorre, 1999).

The reduction of heads m<sup>-2</sup> due to increased row width is adequately explained by the tendency of reduced heads plant<sup>-1</sup> as row widths increased in all trials in this study. This

is a direct result of the increased competition for resources in the wider row widths, which usually produces smaller plants that tiller less (Schoonwinkel *et al.*, 1991). The 250 and 300 mm row widths did not differ significantly from each other in any of the trials, but competition in the 350 mm row width became so fierce that the number of heads plant<sup>-1</sup> was reduced in all cases. In the Southern Cape trials (Chapter 5) where only 250 and 300 mm row widths were used, significant differences in heads plant<sup>-1</sup> did also not occur due to increases in row width. A general tendency of reduction of heads plant<sup>-1</sup> due to increased row widths was also reported by Holliday (1963) and found in a study with 16 winter wheat cultivars in Indiana (Marshall & Ohm, 1987).

An increase in the number of kernels head<sup>-1</sup> can compensate for a reduced head population per unit area or reduced number of heads plant<sup>-1</sup> caused by increased row widths (Lafond, 1994). At wider row widths, where a reduced number of heads m<sup>-2</sup> occurred, a significant increase in the number of kernels head<sup>-1</sup> was found in only one of the four trials conducted (Moorreesburg 2005). Similar but non-significant trends were found in the other three trials. Likewise, a significant response was also found at only one trial in the Southern Cape study at Riversdale in 2006 (Chapter 5). A study by Schoonwinkel *et al.* (1991) in the Swartland reported increases in grain weight (g head<sup>-1</sup>) at wider row widths and low planting densities as compensation for the reduction in head populations in one out of two seasons. Similar compensation was not found by Johnson *et al.* (1988) in a study with SRWW in the Great Plains.

An increase in kernel weight (TKM) can compensate for early setbacks (reduced numbers of heads or kernels per unit area), but only if conditions remain favourable during the grain filling stage (Laubscher, 1986; Lafond, 1994). Kernel weight was not affected by increases in row width, indicating that no compensation for reduced head populations due to increased row width was found in the Swartland trials, even in 2006 when 35 mm and 57 mm of rain occurred during the grain filling period (September-October) at Hopefield and Moorreesburg respectively, most possibly creating very favourable grain filling conditions. Therefore compensation for reduced numbers of heads plant<sup>-1</sup> by increased kernel weight, seem to be unlikely in this region.

### ***Response to planting density***

The number of heads m<sup>-2</sup> increased significantly when planting density was increased at both localities in the 2006 season. These increases in head population can be attributed to the increases in established seedlings m<sup>-2</sup> (due to planting density treatments) which were determined in the beginning of the growing season at each locality (Figure 4.1). Such increases in head population by increased planting density have been reported in



studies in the Swartland (Laubscher, 1986; Schoonwinkel *et al.*, 1991; Agenbag, 1992), as well as in other Mediterranean environments (Anderson & Barclay, 1991; Lithourgidis *et al.*, 2006), for spring wheat in Canada and North America (Lafond, 1994; Carr *et al.*, 2003) and for winter wheat (Puckridge & Donald, 1967; Johnson *et al.*, 1988; Lafond & Gan, 1999).

In an inverse relationship, the number of heads plant<sup>-1</sup> decreased significantly as planting density increased in all four trials. This inverse relationship is due to increased tiller mortality per plant as plant population (and competition between plants) increases (Puckridge & Donald, 1967; Satorre, 1999). At lower planting densities, competition between individual plants is less severe, more tillers survive, which will compensate to some extent for the reduction in plant population. However, this compensation will depend on availability of resources (water nutrition and light) between tillering and anthesis and full compensation (the same head population at a wide range of planting densities) can only be achieved if resources are virtually unlimited (Satorre, 1999). To reach full compensation, the number of heads plant<sup>-1</sup> must be 2.5 times greater at the low planting density (100 target (no.) of plants m<sup>-2</sup>). In all four trials, the number of heads plant<sup>-1</sup> was only two times more when the planting density decreased from 250 to 100 target (no.) of plants m<sup>-2</sup> for example 2.4 to 1.2 at Moorreesburg in 2005 and 2.0 to 1.0 at Hopefield in 2006. It can therefore be concluded that very low planting densities should be avoided to ensure sufficient head populations in this region.

Results with regards to the response of number of kernels head<sup>-1</sup> to increasing planting density were inconclusive with no significant differences in any of the trials, except Hopefield in 2006, when the number of kernels head<sup>-1</sup> increased as planting density increased. The response at Hopefield in 2006 was also the opposite to the response found at Caledon in 2005 in the Southern Cape region when the number of kernels head<sup>-1</sup> decreased significantly with an increase in planting density (Table 5.7). The results at Hopefield did also not agree with results of Lafond (1994) who found that the number of kernels head<sup>-1</sup> for HRSW was either unaffected or decreased by increasing planting density. This tendency was also clearly illustrated by Puckridge and Donald (1967) for winter wheat planted at a very wide range of planting densities. Therefore, results in the Swartland indicate that compensation by increased number of kernels head<sup>-1</sup> for reduced head populations seems unlikely in most seasons.

Kernel weight was affected in only one out of four trials (Moorreesburg in 2006) when TKM decreased with increasing planting densities but no interactions between planting densities and cultivars used was found. TKM likewise decreased as result of an increasing planting density at Caledon in 2006 in the Southern Cape (Chapter 5), while a

PD x CV interaction was found at Riversdale in 2006. Carr *et al.* (2003) indicated that TKM is not often affected when planting densities below 136 kg seed ha<sup>-1</sup> are compared. Decreases with increasing planting densities was also shown by Anderson (1986), Anderson and Barclay (1991) as well as Lafond (1994) for HRSW, but Puckridge and Donald (1967) found no significant response in kernel weight for a wide range of planting densities in winter wheat. This response showed that compensation by increased kernel weight for reduced head population is possible in this region, but it will occur only when relatively cool, wet conditions, which will delay leaf senescence, are experienced in the latter portion of the grain fill period (Frederick & Bauer, 1999). In seasons or production areas where the rainy season is short and terminal drought occurs premature (for example 2005), grain filling will be restricted (low TKM) and compensation by producing larger kernels will be unlikely.

## **Conclusion**

These results clearly indicate that increasing row widths decreased the number of heads m<sup>-2</sup> probably due to greater inter-plant competition in wider row widths. This reduction in head population can be ascribed to greater in-row competition as illustrated by the reduction in the number of heads plant<sup>-1</sup>. Although this reduction in head population can be compensated for by increased numbers of kernels head<sup>-1</sup>, it is unlikely that compensation will be sufficient to offset the fewer heads m<sup>-2</sup>, especially if the row widths exceed 300 mm. For this reason row widths should remain as narrow as practically possible.

Relatively high planting densities should be used in this region (above 175 target (no.) plants m<sup>-2</sup>) to ensure sufficient head populations, especially if planting time is delayed towards the latter half of May due to insufficient rainfall before or at the beginning of the season. In cases when planting is postponed, cultivars with shorter growing periods at higher planting densities can be used to ensure sufficient head populations.

## CHAPTER 8

### THE INFLUENCE OF PLANTING DENSITY AND ROW WIDTH ON WHEAT IN CONSERVATION TILLAGE SYSTEMS IN THE WESTERN CAPE. PART 5: GRAIN YIELD, GRAIN PROTEIN AND HECTOLITRE MASS IN THE SWARTLAND

#### Introduction

The introduction of wider row widths as required by the no-till conservation tillage systems raised some concern regarding the possible impact of increased inter-plant competition on grain yield. Very little research on row width with wheat has been done in the Western Cape, but reports by Schoonwinkel *et al.* (1991) on studies in the Swartland indicated that increasing row width (from 175 - 350mm) had a positive impact on grain yield in the below average 1986 season and a negative impact in the above average 1987 season. Although this study gave some indication of possible responses to expect, grain yield responses with the use of modern and effective no-till planters with row widths differing between 250 and 350 mm is not known for this region.

The main aim of this part of the study is therefore to quantify the yield and quality responses of wheat, when the crop is planted in wider rows than were conventionally used in past in the Swartland region of the Western Cape. Wider row widths affect the in-row plant density and the second objective of this study was therefore to evaluate suitable planting densities to be used with wider row widths as required in conservation tillage systems.

#### Experimental procedure

Grain yield and quality parameters were determined at two localities in the Swartland for three seasons. The trial sites and experimental procedures are described in Chapter 3, but a summary of localities, treatments and data collected are given in Table 8.1.

**Table 8.1** Summary of localities, seasons, treatments and data collected at the Swartland localities

Locality	Treatments	Data collected
<b>Moorreesburg</b>	<b>Cultivars:</b>	Grain Yield
	2004 – SST 88, SST 94	Grain Protein
	2005 – SST 88, SST 94	Hectolitre mass
	2006 – SST 88, SST 015	
	<b>Row widths:</b>	
	250, 300 and 350 mm	
	<b>Planting densities:</b>	
	<b>2004</b>	
	150, 200, 250 target (no.) of plants m <sup>-2</sup>	
	<b>2005 and 2006</b>	
100, 175 and 250 target (no.) of plants m <sup>-2</sup>		
<b>Hopefield</b>	<b>Cultivars:</b>	Grain Yield
	2004 – SST 88, SST 94	Grain Protein
	2005 – SST 88, SST 94	Hectolitre mass
	2006 – SST 88, SST 015	
	<b>Row widths:</b>	
	250, 300 and 350 mm	
	<b>Planting densities (all seasons):</b>	
	100, 175 and 250 target (no.) of plants m <sup>-2</sup>	

## Results

Pr>F values for differences between treatment means indicated significant differences in grain yield (ton ha<sup>-1</sup>), grain protein (%) and hectolitre mass (kg hl<sup>-1</sup>) as a result of the treatments applied (Table 8.2).

### Grain yield

*The only season when cultivars differed significantly without interaction was at Moorreesburg and Hopefield in 2005 (Table 8.2). Grain yield of cultivars (CV) differed in significant interactions with planting density (PD x CV) at Moorreesburg in 2004, and in a three way interaction (PD x RW x CV) at Hopefield during this season. Grain yield was also significantly affected by row width (Moorreesburg 2004 and Hopefield 2006) and planting density (Moorreesburg 2004 and 2005; Hopefield 2006) as main factors.*

**Table 8.2** Pr >F values, and coefficients of variance of the main effects and interactions in the Swartland Cape trials during the period 2004-2005 (p<0.05)

	<b>Moorreesburg</b>			<b>Hopefield</b>		
	<b>Yield</b>	<b>Prot.</b>	<b>HLM</b>	<b>Yield</b>	<b>Prot.</b>	<b>HLM</b>
	<b>2004</b>					
<b>Cultivar</b>	ns	ns	0.005	ns	ns	ns
<b>Row width</b>	0.029	ns	ns	ns	ns	ns
<b>RW x CV</b>	ns	ns	ns	ns	ns	ns
<b>Planting Density</b>	0.045	ns	ns	ns	ns	ns
<b>PD x CV</b>	0.005	ns	ns	0.005	ns	ns
<b>PD x RW</b>	ns	ns	ns	0.025	ns	ns
<b>PD x RW x CV</b>	ns	ns	ns	0.037	ns	ns
<b>Cv (%)</b>	7.9	4.2	1.0	12.6	4.2	2.2
<b>Appendix no.</b>	<b>E-1</b>	<b>E-4</b>	<b>E-7</b>	<b>E-10</b>	<b>E-13</b>	<b>E-16</b>
	<b>2005</b>					
<b>Cultivar</b>	0.012	ns	ns	0.030	0.036	ns
<b>Row width</b>	ns	ns	ns	ns	ns	ns
<b>RW x CV</b>	ns	ns	ns	ns	ns	ns
<b>Planting Density</b>	0.007	ns	<0.001	ns	ns	ns
<b>PD x CV</b>	ns	ns	ns	ns	ns	ns
<b>PD x RW</b>	ns	ns	ns	ns	ns	ns
<b>PD x RW x CV</b>	ns	ns	0.046	ns	ns	ns
<b>Cv (%)</b>	11.2	6.3	1.3	14.8	5.1	4.5
<b>Appendix no.</b>	<b>E-2</b>	<b>E-5</b>	<b>E-8</b>	<b>E-11</b>	<b>E-14</b>	<b>E-17</b>
	<b>2006</b>					
<b>Cultivar</b>	ns	ns	0.031	ns	ns	0.010
<b>Row width</b>	ns	ns	ns	0.035	0.046	ns
<b>RW x CV</b>	ns	0.041	ns	ns	ns	ns
<b>Planting Density</b>	ns	0.030	ns	0.008	ns	ns
<b>PD x CV</b>	ns	ns	ns	ns	ns	ns
<b>PD x RW</b>	ns	ns	ns	ns	ns	ns
<b>PD x RW x CV</b>	ns	ns	ns	ns	ns	0.049
<b>Cv (%)</b>	11.5	1.5	1.1	16.3	2.2	2.0
<b>Appendix no.</b>	<b>E-3</b>	<b>E-6</b>	<b>E-9</b>	<b>E-12</b>	<b>E-15</b>	<b>E-18</b>

Yield = grain yield (ton ha<sup>-1</sup>), Prot.= grain protein (%), HLM = Hectolitre mass (kg hl<sup>-1</sup>), ns = not significant. CV=Cultivar, RW=row width, PD=planting density and Cv (%) = the coefficient of variance

The significant cultivar x planting density interaction for grain yield at Moorreesburg in 2004 indicates that SST 94 produced a significantly higher grain yield (2.910 ton ha<sup>-1</sup>) at the highest planting density treatment (250 target (no.) of plants m<sup>-2</sup>) if compared to the 2.487 ton ha<sup>-1</sup> of the 100 target (no.) of plants m<sup>-2</sup> treatment (Table 8.3), while grain yield of SST 88 was not affected by increasing planting densities. During this season, the trial was planted very late, on 12 June 2004 (Table 3.7), outside the recommended optimum planting time due to very late first rains.

**Table 8.3** The planting density (PD) x cultivar (CV) interaction for grain yield (ton ha<sup>-1</sup>) at Moorreesburg 2004

Cultivar	Grain yield (ton ha <sup>-1</sup> )			
	Planting density (Target plants m <sup>-2</sup> )			
	100	175	250	Mean
<b>SST 94</b>	2.487 c	2.791 ab	2.910 a	<b>2.729</b>
<b>SST 88</b>	2.705 abc	2.591 bc	2.658 abc	<b>2.651</b>
<b>Mean</b>	<b>2.596 a</b>	<b>2.691 ab</b>	<b>2.784 b</b>	<b>2.690</b>

LSD<sub>(0.05)</sub> Cultivars = ns

LSD<sub>(0.05)</sub> Planting densities = 0.1456

LSD<sub>(0.05)</sub> PD x CV interaction = 0.2324

Means within the interaction followed by the same letter do not differ significantly. Means within a row (planting density) indicated in bold, do not differ significantly if followed by the same letter.

At Hopefield a three way interaction for grain yield occurred between planting densities, row widths and cultivars (PD x RW x CV) in 2004 which indicated that cultivars responded differently to combinations of these factors during this season (Table 8.4). This interaction indicates that with SST 88, planting density treatments did generally not influence grain yield when it was used at different row widths. However there is a tendency for grain yield to decrease when row widths increase and therefore the highest yield with this cultivar (1.715 ton ha<sup>-1</sup>) was found at the narrow row width (250 mm) and the lowest planting density (150 target (no.) of plants m<sup>-2</sup>). With SST 94 (the short growing season cultivar) the tendency was for grain yield to increase with increasing planting densities at narrow row widths (250 mm) but at wider row widths (300 to 350 mm), grain yield was reduced when 200 target (no.) of plants m<sup>-2</sup> was exceeded.

**Table 8.4** The significant cultivar (CV) x row width (RW) x planting density (PD) interaction found for grain yield (ton ha<sup>-1</sup>) at Hopefield in 2004

Row width (mm)	Planting density (Target (no.) of plants m <sup>-2</sup> )			
	150	200	250	Mean
<b>SST 88</b>				
250	1.715 abc	1.637 abc	1.510 bcd	<b>1.621</b>
300	1.360 cd	1.372 bcd	1.498 bcd	<b>1.410</b>
350	1.529 bcd	1.318 cd	1.126 d	<b>1.324</b>
<b>Mean</b>	<b>1.534 ef</b>	<b>1.442 e</b>	<b>1.378 e</b>	<b>1.451</b>
<b>SST 94</b>				
250	1.424 bcd	1.708 abc	2.031 a	<b>1.721</b>
300	1.270 d	1.633 abc	1.346 cd	<b>1.422</b>
350	1.406 bcd	1.811 ab	1.269 d	<b>1.495</b>
<b>Mean</b>	<b>1.367 e</b>	<b>1.717 f</b>	<b>1.555 ef</b>	<b>1.546</b>
<b>Grand mean (PD)</b>	<b>1.451</b>	<b>1.580</b>	<b>1.466</b>	<b>1.499</b>

Means in the PD x RW x CV interaction followed by the same letter (a - d) are not significantly different. Means in the PD x CV interaction (indicated in bold) followed by the same letter (e - f) are not significantly different.

LSD<sub>(0.05)</sub> PD = ns

LSD<sub>(0.05)</sub> RW x CV = ns

LSD<sub>(0.05)</sub> PD x CV = 0.2127

LSD<sub>(0.05)</sub> PD x RW x CV = 0.4103

In 2005, the two cultivars used, SST 94 and SST 88 differed significantly from each other without significant interactions at both the Moorreesburg and Hopefield localities (Table 8.2). At Moorreesburg, the cultivar with a shorter growing period, SST 94 (Table 3.6), out yielded SST 88 by 0.801 ton ha<sup>-1</sup> (2.507 vs 1.706 ton ha<sup>-1</sup>) while at Hopefield, the yield difference was 0.649 ton ha<sup>-1</sup> (2.470 vs 1.821 ton ha<sup>-1</sup>) as indicated in Table 8.5. Although these trials were planted earlier than in 2004 (24 and 25 May 2005, Table 3.7) and within the recommended planting time, the growing season ended pre-maturely due to low rainfall conditions from September onwards (Table 3.5).

**Table 8.5** Treatment means for planting densities (PD) and cultivars (CV) for grain yield (ton ha<sup>-1</sup>) at Moorreesburg and Hopefield during 2005

Cultivar	Planting density (Target (no.) of plants m <sup>-2</sup> )							
	Moorreesburg				Hopefield			
	100	175	250	Mean	100	175	250	Mean
<b>SST 94</b>	2.158	2.736	2.627	<b>2.507 a</b>	2.283	2.482	2.644	<b>2.470 e</b>
<b>SST 88</b>	1.591	1.709	1.817	<b>1.706 b</b>	1.966	1.830	1.668	<b>1.821 f</b>
<b>Mean</b>	<b>1.874 c</b>	<b>2.223 d</b>	<b>2.222 b</b>	<b>2.106</b>	<b>2.125</b>	<b>2.156</b>	<b>2.156</b>	<b>2.146</b>

LSD<sub>(0.05)</sub> Cultivars = 0.3855

LSD<sub>(0.05)</sub> Planting densities = 0.2371

LSD<sub>(0.05)</sub> PD x CV interaction = ns

LSD<sub>(0.05)</sub> Cultivars = 0.1155

LSD<sub>(0.05)</sub> Planting densities = ns

LSD<sub>(0.05)</sub> PD x CV interaction = ns

Cultivar means (a-b, e-f) within a column and planting density means (c-d) within a row (indicated in bold) do not differ significantly if followed by the same letter.

During 2006, no significant differences ( $p>0.05$ ) in grain yield or significant interactions between cultivars and any of the other treatments applied were found at Moorreesburg or Hopefield indicating that the two cultivars used SST 88 and SST 015 reacted similarly to increases in row widths and planting densities during this season (Table 8.2).

Grain yield was significantly influenced by row width in Moorreesburg in 2004 (Table 8.2). Figure 8.1 indicate that grain yield was reduced from 2.828 ton ha<sup>-1</sup> with the 250 mm row width to 2.635 and 2.607 ton ha<sup>-1</sup> at the 300 and 350 mm row widths respectively.

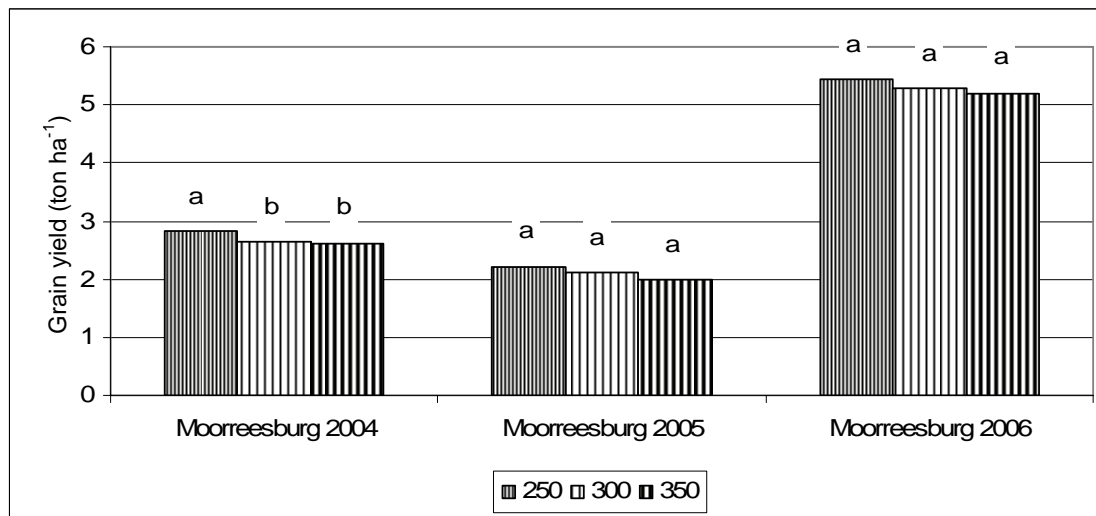

**Figure 8.1** The influence of row width on grain yield (ton ha<sup>-1</sup>) at Moorreesburg 2004-2006. LSD<sub>(0.05)</sub> Moorreesburg 2004 = 0.1639.

Row width also influenced grain yield significantly at Hopefield in 2006 when the highest mean grain yield (Table 8.6) was found with the 300 mm row width (3.280 ton ha<sup>-1</sup>) which differed significantly from the widest (350 mm) row width (2.767 ton ha<sup>-1</sup>), but not from the narrower (250 mm) row width (3.030 ton ha<sup>-1</sup>).

**Table 8.6** Treatment means for row widths (RW) and planting density (PD) for grain yield (ton ha<sup>-1</sup>) at Hopefield 2006

Row width (mm)	Planting density (Target (no.) of plants m <sup>-2</sup> )			
	100	175	250	Mean
250	2.840	3.010	3.239	3.030 ab
300	2.904	3.288	3.649	3.280 a
350	2.523	2.698	3.081	2.767 b
Mean	2.756 c	2.999 cd	3.323 d	3.026

LSD<sub>(0.05)</sub> Row width = 0.3660

LSD<sub>(0.05)</sub> Planting density = 0.3402

LSD<sub>(0.05)</sub> PD x CV interaction = ns

Means for row widths followed by the same letter (a - b) do not differ significantly. Means for planting densities followed by the same letter (c - d) do not differ significantly.



Grain yield was significantly influenced by planting density in Moorreesburg in 2004 (Table 8.2) as discussed in the CV x PD interaction above (Table 8.3). In 2005, average yields increased with increases in planting density from 1.874 ton ha<sup>-1</sup> at the lowest planting density of 100 target (no.) of plants m<sup>-2</sup> to 2.223 and 2.222 ton ha<sup>-1</sup> at planting densities of 175 and 250 target (no.) of plants m<sup>-2</sup> respectively at this locality (Table 8.5).

At Hopefield grain yield was significantly influenced by planting in 2004 as discussed in the significant three way (PD x RW x CV) interaction (Table 8.4), but no significant response to planting density was found at this locality in 2005 (Table 8.5). In 2006, grain yield again showed a positive response to increased planting density (Table 8.6), with 3.23 ton ha<sup>-1</sup> produced with the highest planting density treatment (250 target (no.) of plants m<sup>-2</sup>), which differed significantly from the 2.756 ton ha<sup>-1</sup> produced at the lowest planting density treatment (100 target (no.) of plants m<sup>-2</sup>). The 2.999 ton ha<sup>-1</sup> of the intermediate planting density treatment (175 target (no.) of plants m<sup>-2</sup>) did not differ significantly from the other two treatments.

### **Grain Protein (%)**

*Grain protein (%) was not significantly ( $p>0.05$ ) affected by treatments applied at the Moorreesburg (2004 and 2005) and Hopefield localities (2004), but cultivars differed significantly at Hopefield in 2005 (Table 8.2). In 2006 grain protein at Moorreesburg was significantly affected by different planting densities used and also showed a significant interaction between cultivars and row width. At Hopefield, grain protein was influenced significantly by row width.*

The two cultivars SST 94 and SST 88 differed significantly in grain protein (%) at Hopefield 2005 with the cultivar SST 94 at 10.96% and SST 88 at 12.09% (Table 8.7). These results correspond with different yield levels in cultivar x row width interaction found for grain yield in this season (Table 8.5). These differences are fairly large and would have affected the grading of these two cultivars.

**Table 8.7** Treatment of row widths and planting densities for grain protein (%) at Hopefield in 2005 and 2006

Cultivar	Grain protein (%)							
	2005				2006			
	Row widths (mm)				Row widths (mm)			
	250	300	350	Mean	250	300	350	Mean
<b>SST 94</b>	10.84	10.78	11.27	<b>10.96 a</b>	-	-	-	-
<b>SST 88</b>	12.40	11.99	11.89	<b>12.09 b</b>	11.48	11.85	11.84	<b>11.72</b>
<b>SST 015</b>	-	-	-	-	11.47	11.37	11.55	<b>11.46</b>
<b>Mean</b>	<b>11.62</b>	<b>11.38</b>	<b>11.51</b>	<b>11.53</b>	<b>11.48 c</b>	<b>11.61 cd</b>	<b>11.69 d</b>	<b>11.59</b>

LSD<sub>(0.05)</sub> Cultivars = 0.9457

LSD<sub>(0.05)</sub> Row widths = ns

LSD<sub>(0.05)</sub> RW x CV interaction = ns

Means for Cultivars (2005) followed by the same letter (indicated in bold) do not differ significantly if followed by the same letter (a-b). Means for row widths in 2006 (indicated in bold) do not differ significantly if followed by the same letter (c-d).

LSD<sub>(0.05)</sub> Cultivars = ns

LSD<sub>(0.05)</sub> Row widths = 0.1618

LSD<sub>(0.05)</sub> RW x CV interaction = ns

In the interaction between cultivars and row widths at Moorreesburg in 2006, grain protein (%) differed significantly between SST 015 and SST 88 at the two narrower row widths (250 and 300 mm), but not at the widest (350 mm) row width (Table 8.8). However no significant differences or interactions for grain yield, which could have affected grain protein, were found at this locality in this season (Table 8.2).

Row widths also affected grain protein at Hopefield in 2006 (Table 8.2) when grain protein increased slightly but significantly from 11.48% to 11.69% with increasing row widths and corresponded with grain yields affected by row widths in this trial (Table 8.7).

Planting density treatments affected grain protein slightly but significantly at Moorreesburg in 2006 with grain protein increasing significantly from 11.17% to 11.31% as planting density increased from 100 target (no.) of plants m<sup>-2</sup> to 175 and 250 target (no.) of plants m<sup>-2</sup> (Table 8.8).

**Table 8.8** The cultivar (CV) x row width (RW) interaction and treatment means for planting densities for grain protein (%) at Moorreesburg 2006

	Grain protein (%)							
	Row widths (mm)				Planting density (Target (no.) of plants m <sup>-2</sup> )			
	250	300	350	Mean	100	175	250	Mean
<b>SST 015</b>	11.05 b	11.10 b	11.23 ab	<b>11.13</b>	11.04	11.17	11.17	<b>11.13</b>
<b>SST 88</b>	11.42 a	11.45 a	11.39 ab	<b>11.40</b>	11.31	11.45	11.44	<b>11.40</b>
<b>Mean</b>	<b>11.24</b>	<b>11.28</b>	<b>11.27</b>	<b>11.26</b>	<b>11.17 c</b>	<b>11.31 d</b>	<b>11.31 d</b>	<b>11.26</b>

LSD<sub>(0.05)</sub> Row widths = ns

LSD<sub>(0.05)</sub> Cultivars = ns

LSD<sub>(0.05)</sub> RW x CV interaction = 0.3622

LSD<sub>(0.05)</sub> Planting density = 0.1136

LSD<sub>(0.05)</sub> PD x CV interaction = ns

Means within the (RW x CV) interaction followed by the same letter do not differ significantly if followed by the same letter (a-b). Means for planting densities (indicated in bold) do not differ significantly if followed by the same letter (c-d).

These results indicate that grain protein is sometimes affected indirectly by treatments that affected grain yield. These differences were however fairly small and would mostly not have influenced the grading of the wheat on the basis of protein content (ARC-Small Grain Institute, 2007).

### **Hectolitre mass**

*Hectolitre mass (HLM) was significantly affected by cultivars (CV) at Moorreesburg in 2004 and 2006 as well as at Hopefield in 2006 (Table 8.2), while significant differences in HLM as a result of increasing planting densities were found at Moorreesburg in 2005. Significant interactions between cultivars (CV), planting density (PD) and row width (RW) were found at Moorreesburg 2005 and Hopefield in 2006 (Table 8.2).*

The cultivar differences in hectolitre mass for the period 2004 to 2006 at the Moorreesburg locality are shown in Figure 8.2. In 2004, the HLM of SST 88 (81.4 kg hl<sup>-1</sup>) was significantly higher than that of SST 94 (79.4 kg hl<sup>-1</sup>). In 2006 the HLM of SST 88 (81.1 kg hl<sup>-1</sup>) was also significantly higher than that of SST 015 (78.8 kg hl<sup>-1</sup>) which replaced SST 94 in these trials (Figure 8.2).

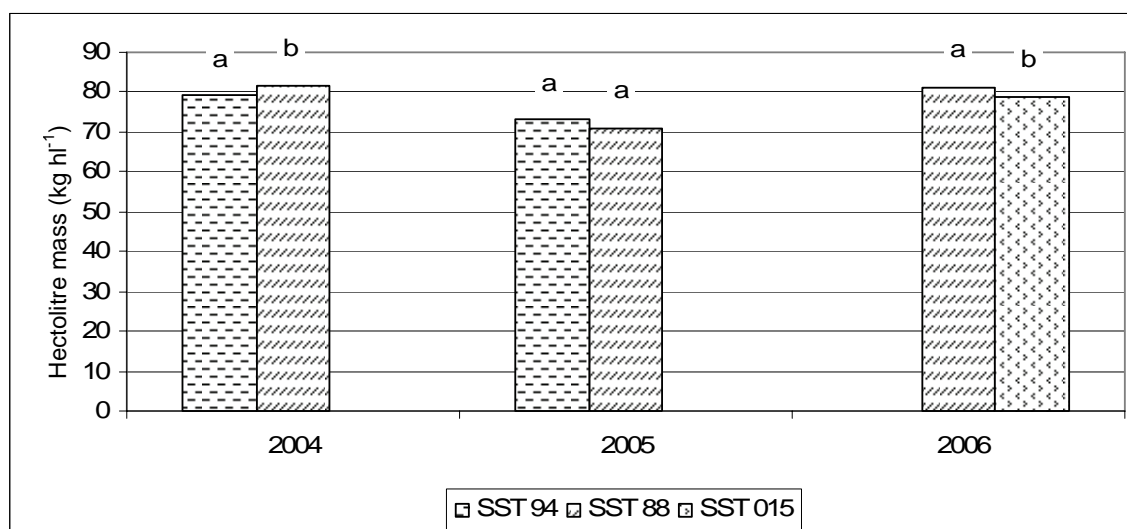

**Figure 8.2** Cultivar differences in hectolitre mass ( $\text{g hl}^{-1}$ ) at Moorreesburg 2004-2006.  $\text{LSD}_{(0.05)} 2004 = 0.629$ ,  $\text{LSD}_{(0.05)} 2006 = 1.774$ .

In 2005 cultivar means did not differ significantly between SST 88 and SST 94 but the significant PD x RW x CV interaction (Table 8.9) indicated a tendency of slightly higher HLM with SST 94. Due to the fairly late planting date (25 May) and low rainfall from September onwards, grain filling would have been affected during the latter part of this season (Table 3.4) which resulted in low hectolitre mass for both cultivars.

**Table 8.9** Planting density (PD) x row width (RW) x cultivar (CV) interaction for hectolitre mass ( $\text{kg hl}^{-1}$ ) at Moorreesburg in 2005

Row width (mm)	Planting density (Target (no.) of plants $\text{m}^{-2}$ )			
	100	175	250	Mean
<b>SST 88</b>				
250	70.3 ab	70.6 cd	72.0 fg	<b>70.9</b>
300	70.4 bc	70.1 a	71.3 e	<b>70.6</b>
350	70.3 ab	72.2 g	72.9 h	<b>71.8</b>
<b>Mean</b>	<b>70.3</b>	<b>70.96</b>	<b>72.6</b>	<b>71.1</b>
<b>SST 94</b>				
250	73.2 ij	73.5 k	73.0 hi	<b>73.2</b>
300	70.7 d	73.4 jk	74.1 m	<b>72.7</b>
350	72.9 h	74.3 n	73.5 k	<b>73.6</b>
<b>Mean</b>	<b>72.3</b>	<b>73.7</b>	<b>73.5</b>	<b>73.2</b>
<b>Grand mean (PD)</b>	<b>71.3 p</b>	<b>72.3 q</b>	<b>72.8 q</b>	<b>72.1</b>

$\text{LSD}_{(0.05)} \text{Cultivars} = \text{ns}$

$\text{LSD}_{(0.05)} \text{Row width} = \text{ns}$

$\text{LSD}_{(0.05)} \text{Planting density} = 0.657$

$\text{LSD}_{(0.05)} \text{PD} \times \text{RW} \times \text{CV} = 0.2260$

Means in the interaction do not differ significantly if followed by the same letter (a-n). Grand means for planting densities (indicated in bold) do not differ significantly if followed by the same letter (p-q).

No consistent trends with regards to the role of increasing row widths can be seen in this interaction (Table 8.9), but there was some tendency for hectolitre mass to increase

slightly with increasing planting density. The low mean hectolitre mass, indicated by the trial average of 72.1 kg hl<sup>-1</sup> (Table 8.9) would have resulted in low grades realised for the crop on the basis of this quality parameter (ARC-Small Grain Institute, 2007).

At Hopefield in 2006, SST 015 tended to produce a higher HLM mass than SST 88 but no clear tendencies with regard to the effect of increasing row widths or the planting density treatments could be seen in the interaction (Table 8.10). The mean cultivar differences would have lead to the cultivars realising different grades in the grading system (ARC-Small Grain Institute, 2007).

**Table 8.10** Planting density (PD) x row width (RW) x cultivar (CV) interaction for hectolitre mass (kg hl<sup>-1</sup>) at Hopefield in 2006

Row width (mm)	Planting density (Target (no.) of plants m <sup>-2</sup> )			
	100	175	250	Mean
<b>SST 88</b>				
<b>250</b>	75.00 abcd	75.80 cdef	74.80 abcd	<b>75.20</b>
<b>300</b>	73.13 ab	75.93 cdef	76.80 cdef	<b>75.29</b>
<b>350</b>	74.53 abc	72.87 a	76.40 cdef	<b>74.60</b>
<b>Mean</b>	<b>74.22</b>	<b>74.87</b>	<b>76.00</b>	<b>75.03 g</b>
<b>SST 015</b>				
<b>250</b>	77.67 ef	75.47 bcde	76.00 cdef	<b>76.38</b>
<b>300</b>	77.53 ef	78.13 f	77.27 def	<b>77.64</b>
<b>350</b>	76.13 cdef	77.93 ef	76.47 cdef	<b>76.84</b>
<b>Mean</b>	<b>77.11</b>	<b>77.18</b>	<b>76.58</b>	<b>76.96 h</b>
<b>Grand mean (PD)</b>	<b>75.67</b>	<b>76.02</b>	<b>76.29</b>	<b>75.99</b>

LSD<sub>(0.05)</sub> Cultivars = 0.829

LSD<sub>(0.05)</sub> Row width = ns

LSD<sub>(0.05)</sub> Planting density = ns

LSD<sub>(0.05)</sub> PD x RW x CV = 2.465

Means in the interaction do not differ significantly if followed by the same letter (a-f). Grand means for cultivars (indicated in bold) do not differ significantly if followed by the same letter (g-h)

In general, these results indicate that cultivars, due to genetic differences, dominated the results with regards to hectolitre mass, while row width and planting density had very little effect on this parameter.

## Discussion

### *Cultivar response*

In these trials, SST 88 did not always yield well when the seasons were shortened by late planting (2004) or when terminal drought occurred early (2005). SST 94 which has the shortest growing period of cultivars available (90 - 98 days to anthesis after emergence) matured early and produced higher yields under these conditions by escaping the terminal drought to some extent. The fact that cultivars were involved in

interactions with row widths (Hopefield 2005), planting densities (Moorreesburg 2004) and in a three-way interactions (PD x RW x CV) at Hopefield in 2004, indicated that cultivar response could be influenced by these factors or combinations of them. For example, in the three way interaction at Hopefield 2004, SST 88 did not respond significantly to an increase in planting density at any row width, but grain yield of SST 94 did benefit from increased planting densities, but only when row widths remained narrow. This is probably an indication that the competition threshold (as reported by McLeod *et al.*, 1996) has been exceeded in the wide rows. Similar interactions found by other authors (Marshall & Ohm, 1978; Briggs & Aytenu, 1979; Ciha, 1983; Del Cima *et al.*, 2004) showed that yield responses of different cultivars were affected by row widths and planting densities in their studies. However no interactions between these factors were found in the Southern Cape trials (Chapter 6) indicating different responses in the two regions represented in this study. These differences between regions could be ascribed to differences in planting date (Table 3.7) and less reliable rainfall in the Swartland during the 2004 and 2005 seasons, especially late in the season, which lead to early terminal drought in 2005 (Table 3.5). The sandy soils of Hopefield which dry out quickly and are prone to periodic dry periods during the season could also have resulted in these interactions in which cultivars responded differently. Acevedo *et al.* (1999) stresses the importance of early planting and cultivar choice to suit the growing season in order to escape early terminal drought, especially in Mediterranean environments and soils with low water storage capacity.

Grain protein content was significantly affected in three out of the six trials in this study, and in all three cases cultivars were involved either directly or in an interaction with row widths or planting density. According to Slafer *et al.* (2002) grain protein is often linked to genetic factors, but it can also be influenced by inter-plant competition caused by factors such as increased row widths or planting density. Differences in yield levels of cultivars and the effect of increasing row widths and planting densities on grain yield could therefore have had an indirect influence on grain protein. Similar to grain protein, differences in HLM were strongly linked to the genetic influence of cultivars. Results of interactions between cultivars and the other two factors (PD x RW x CV) found in Moorreesburg in 2005 and Hopefield in 2006 were inconsistent and trends in this regard were not clear. Ciha (1983) found that HLM is generally reduced at late planting dates, which was not the case in this study in 2004, when the crop was established outside the recommended planting time. However when the growing period was shortened due to early terminal drought in 2005, HLM was dramatically reduced.

### **Response to row width**

In the Swartland grain yield was affected by increasing row widths in three out of the six trials, indicating that row width has a considerable influence on grain yield in this region. During 2004 when the crop was established late (outside the recommended planting time) due to insufficient rainfall at the beginning of the season (Table 3.4), the normal growing season was shortened by at least two weeks. During this season, the negative effect of increasing row widths was most pronounced with significant yield reductions at both localities. At Moorreesburg, which received higher in-season rainfall and where the soil has slightly better water storage capacity, yield differences without interactions with the other two factors, cultivars and planting densities occurred. In this case, grain yield was reduced significantly by  $193 \text{ kg ha}^{-1}$  (6.8%) when row widths increased from 250 mm to 300 mm.

At Hopefield, the locality with sandy soils which dry out quickly and which had lower rainfall during the growing season, the significant PD x RW X CV interaction for grain yield indicated that increased competition by increased row widths could have serious consequences. In this interaction, grain yield of SST 94 was significantly reduced from  $2.031 \text{ ton ha}^{-1}$  with the narrow row width (250 mm) and a high planting density (250 target (no.) plants  $\text{m}^{-2}$ ) to  $1.346 \text{ ton ha}^{-1}$  as row width increased to 300 mm at the same planting density. These results represent substantial decreases in grain yield of  $685 \text{ kg ha}^{-1}$  (33.7%) at the 300 mm row width and  $869 \text{ kg ha}^{-1}$  (42.8%) at the 350 mm row width. However, no significant difference between this grain yield ( $2.031 \text{ ton ha}^{-1}$ ) was measured when a lower planting density (200 target (no.) plants  $\text{m}^{-2}$ ) was used at any row width, indicating that very high planting densities can have a negative, rather than positive, effect when rows wider than 250 mm are used. This was in contrast with the results of a study in the Swartland by Schoonwinkel *et al.* (1991) who found that in the below average 1986 season (with similar yield levels to the Hopefield 2004 trial) higher grain yield was produced with wider row widths (350 mm) and yield was not effected as planting densities increased in these wide rows. In this interaction, grain yield however increased with increasing planting densities when narrow row widths (175 mm) were used.

During the 2005 season, the crop was established within the recommended planting time at both localities and rainfall remained favourable until the end of August, with low rainfall in September (the period around anthesis) and very low rainfall in October (grain filling stage) resulted in low grain yields of  $2.1 \text{ ton ha}^{-1}$  at both localities (Table 8.5). The lack of rainfall during this period (Table 3.5) in combination with soils with low water holding capacity and high water demand by the crop during late growth stages, most probably resulted in a terminal drought situation. The effect of this early cut-off of rain

can be seen in low TKM (27 g at Moorreesburg and 30 g at Hopefield (Figure 7.7) and low HLM mass at both localities (Table 8.9). At both localities the number of heads  $m^{-2}$  (Figure 7.2) and the number of heads  $plant^{-1}$  (Figure 7.3) was significantly reduced by increasing row widths, indicating the negative impact of increased competition.

At Moorreesburg this reduction in the number of heads  $m^{-2}$  did however not result in a significant grain yield reduction due to some compensation by increased kernels  $head^{-1}$  at the widest (350 mm) row width (Figure 7.5). In a significant RW x CV interaction at Hopefield, SST 94 (the cultivar with a shorter growing season) which yielded 2.633 ton  $ha^{-1}$  when planted in narrow (250 mm) rows, by far outperformed the wider row width treatments with a significant 9.4% yield advantage over the wider (300 mm) row width. These results did also not agree with the findings of Schoonwinkel *et al.* (1991) who found that wide rows (350 mm) had a yield advantage in 1986, a season with similar yield levels.

The 2006 season was characterised by excellent rainfall, during and after crop establishment followed up by reliable rainfall throughout the growing season (Table 3.5), which resulted in above average grain yields at both localities. These wet conditions during seedling establishment ensured very high seedling survival at both localities (average of 91.7% at Moorreesburg and 87.2% at Hopefield, Chapter 4) despite the increases in row widths. Notwithstanding these favourable rainfall conditions, the number of heads  $m^{-2}$  was reduced with every increase in row width (Table 7.2) and the number of heads  $plant^{-1}$  was reduced when row width exceeded 300 mm (Table 7.3). Grain yield was not significantly reduced by increasing row widths at Moorreesburg, but the form of compensation for the reduced number of heads  $m^{-2}$  was not clear, as no significant differences in the number of kernels  $head^{-1}$  (Figure 7.6) or increased kernel weight (Table 7.2) was found. In contrast with these findings, Schoonwinkel *et al.* (1991) found that significantly higher yields were achieved with narrower row widths in the above average 1987 season which had similar yield levels to this trial, which could be an indication that improved soil conditions in conservation tillage systems and modern day cultivars have a greater ability to compensate.

Grain yield at Hopefield in 2006 was significantly reduced by increasing row width without interaction with the other two factors, only when the widest row width (350 mm) was used, indicating less sensitivity for increasing row widths during this season in comparison with the previous two seasons, most probably due to more reliable rainfall. This reduction in grain yield at the widest row width (15.6%) correlated with a significant reduction in the number of heads  $m^{-2}$  (Figure 7.3) and no significant compensation by increased kernels  $head^{-1}$  (Figure 7.5) or increased kernel weight (Table 7.2).



The significant reduction in grain yield due to increases in row widths often seen in this study could be ascribed to increased inter-plant competition for resources which lead to reduced head populations (caused by reduced numbers of heads plant<sup>-1</sup>). Yield reduction due to increased competition has been described by various authors (Holliday, 1963; Doyle, 1980; Frederick & Marshall, 1985; Burch & Perry, 1986, Marshall & Ohm, 1987; Johnson *et al.*, 1988; Schoonwinkel *et al.*, 1991; Shackley *et al.*, 2000; Newton, 2002) for different types of wheat in different environments. Although, compensation does occur for the reduced head populations in this region, as described by Lafond (1994), McLeod *et al.* (1996), Lafond and Gan (1999) and Hiltbrunner *et al.* (2005) it does not seem to be adequate to reduce the affect of wide row widths to acceptable levels, especially at localities like Hopefield which is prone to intermittent drought periods due to soil and/or climatic factors.

Increasing row widths had very little influence on the quality parameter grain protein as significant differences were found in only two out of the six trials. In the case of the significant RW x CV interaction at Moorreesburg in 2006, only slight differences in grain protein due to different row widths were measured. At Hopefield in 2006 an increase in grain protein corresponded with a decrease in yield levels as row widths increased. As was the case in Moorreesburg, these differences were negligible in terms of the grading of the crop. McLeod *et al.* (1996) also concluded that grain protein content was inversely related to moisture availability during the season (dependent of rainfall) and that grain protein was not greatly affected by row width. HLM was affected by row width in only two out of the six trials (Moorreesburg 2005 and Hopefield 2006) within significant PD x RW x CV interactions. However no consistent trends with regards to the role of row width in these interactions could be identified. Small but significant row width effects on HLM were also reported by McLeod *et al.* (1996) in only four out of eleven site-seasons.

### ***Response to planting density***

Grain yield was significantly influenced by planting density treatments which provided a range of established plants from 100 to 250 plants m<sup>-2</sup>, in four out of the six trials, indicating that planting density was an important yield determining factor in this region. Interactions with cultivars which occurred at both localities in 2004, were probably due to the growing period being shortened due to late planting (Table 3.7). These interactions indicated different grain yield responses by cultivars to the factors row width and planting density, which is not similar to the responses found in the Southern Cape study (Chapter 6).

Grain yield increased (without interactions) with increases in planting density up to 175 target (no.) of plants  $m^{-2}$ , despite the number of heads  $m^{-2}$  not showing significant differences at Moorreesburg in 2005 (Table 7.3). At Hopefield in 2006 the significant increasing trend in the number of heads  $m^{-2}$  when planting densities were increased, resulted in significant yield increases up to 175 target (no.) of plants  $m^{-2}$ .

In both these interactions, namely the PD x CV at Moorreesburg in 2004 and PD x RW X CV at Hopefield 2004, little benefit in increasing planting densities above 175 target (no.) of plants  $m^{-2}$  was shown, except when SST 94 (with a short growing period) was planted in narrow (250 mm) rows at high planting densities in a shortened growing season. These results therefore indicate that the competition threshold when wide plant rows are used in conservation tillage systems is probably in the region of 175 to 200 established plants  $m^{-2}$ .

In this region, compensation by increased numbers of heads  $plant^{-1}$  at low planting densities was seen at both localities in 2005 and 2006, but this compensation was not sufficient to produce similar numbers of heads  $m^{-2}$  at all planting densities (Table 7.3). These results concur with the findings of Lafond (1994) and Schwarte *et al.* (1996) who found that for spring wheat, plant population, head population and grain yield is directly related to planting density and therefore increases in grain yield due to increases in planting density, are due to more plants being established and therefore more heads  $m^{-2}$  being produced. No significant compensation by increased numbers of kernels  $head^{-1}$  (which occur in the period around anthesis) were seen at any of the localities and compensation by increased kernel weight (which occurs late in the season during the grain filling stage) was seen only at Moorreesburg in 2006, when late rainfall extended grain filling. These results also agree with Lafond (1994) who found that the number of kernels  $head^{-1}$  was not related to planting density and that kernel weight is sometimes not affected or reduced with high planting densities. The lesser extent to which compensation occurs in this region, due to soil and climatic factors that do not support tillering and tiller survival to the same extent as the Southern Cape region, necessitates that fairly high planting densities (above 175 target (no.) of plants  $m^{-2}$ ) must be used to ensure sufficient plant stands and head populations.

The quality parameter grain protein was influenced by planting density in only one of the six trials (Moorreesburg 2006) when grain protein increased slightly with increases in planting density. HLM was only influenced by planting density in three-way PD x RW x CV interactions at Moorreesburg in 2005 and Hopefield in 2006. These interactions indicated slight increases in HLM as planting density was increased. McLeod *et al.*

(1996) also found that grain protein was not normally affected by planting densities, but that test weights (HLM) generally increase with increasing planting density.

## **Conclusion**

In the Swartland, the late maturing cultivar SST 88 was out yielded by SST 94, a cultivar with a shorter growing period in 2004 and 2005, indicating the importance of including cultivars with different growing periods when cultivar choices are made in this region. As tillering could be more restricted in the region due to soil and climatic conditions, more emphasis should be placed on cultivars with medium or short growing periods, which seem to be better adapted to this region.

The Swartland region is clearly sensitive to increases in row width which resulted in significantly decreased head populations due to increased competition for resources at both localities in 2005 and 2006. Although compensation for decreased head populations may occur at localities where soils have sufficient water holding capacity and if rainfall remains favourable during the season, sufficient compensation (which occurs later in the season) was shown to be unlikely in this study in most seasons. Therefore row widths in this region should remain as narrow as practically possible to allow sufficient stubble handling of the no-till planter. Row widths wider than 300 mm should not be considered due to the negative effect of competition at such wide row widths.

Results on the use of planting densities in wide rows indicated that the competition threshold for planting densities may be in the order of 175 to 200 target (no.) of plants  $m^{-2}$ , in seasons when the crop is established within the recommended planting time. This is only slightly lower than the currently recommended 200 to 230 plants  $m^{-2}$  for wheat production in the Swartland (Agenbag, 1992). More detailed information, on a wider range of cultivars and planting densities will however be needed to determine the optimum planting densities required for the cultivars available in this region.

## CHAPTER 9

### SOME RELATIONSHIPS BETWEEN THE COMPONENTS OF YIELD AND FINAL RECCOMENDATIONS

#### Introduction

From the previous chapters it became clear that the yield responses due to row width, planting density and cultivar treatments applied varies between localities and seasons. In this chapter an attempt will be made to summarize and analyze the responses. The yield component approach is a popular, crop physiological way to understand yield from simpler attributes (Slafer, 2007). With this approach, grain yield is divided into two major numerical components, the number of kernels  $m^{-2}$  and the average individual kernel weight. The number of kernels  $m^{-2}$  can then be sub-divided into various sub-components such as plants  $m^{-2}$ , number of tillers  $plant^{-1}$ , number of heads  $m^{-2}$ , number of heads  $plant^{-1}$ , number of kernels  $head^{-1}$ , number of spikelets  $head^{-1}$  and number of kernels  $spikelet^{-1}$ .

Of these yield components, a sufficient number of heads per unit area (head population) is widely accepted as one of the most important attributes which can be controlled by cultural practices to optimise the grain yield response (Satorre, 1999). Sufficient head populations can be achieved by ensuring that a sufficient number of seedlings survive and that sufficient resources (water and nutrients), to sustain early growth and development, are supplied. Establishment of sufficient plant populations and therefore heads per unit area, by ensuring sufficient plant establishment, has always been a priority in wheat production in the Western Cape (Laubscher, 1986; Schoonwinkel *et al.*, 1991; Agenbag, 1992). During the mid-eighties when conventional planting methods were almost exclusively used in the Western Cape, seedling survival was considered to be only 50% (Laubscher, 1986). High planting densities (up to 160 kg seed  $ha^{-1}$ ) were recommended (Agenbag, 1992) to achieve sufficient plant establishment and head populations as spring wheat cultivars have limited tillering ability. Tillering can also be restricted by climatic and soil conditions which are not always optimal due to the fact that the crop is rainfed, especially in seasons when the growing season starts late due to inadequate autumn rainfall. Changes in practices from conventional planting methods (broadcasting and planting in narrow rows in tilled soils) to the no-till planting method, have lead to higher seedling survival rates (Chapter 4) but also the use of wider row widths which can have an influence on yield response to planting density. Changes in

the characteristics of modern-day cultivars could also influence this response. In this chapter the relationships of three important components of yield (number of plants  $\text{m}^{-2}$ , the number of head bearing tillers  $\text{m}^{-2}$  and the number of heads  $\text{plant}^{-1}$ ) between each other and with grain yield itself ( $\text{ton ha}^{-1}$ ), will be discussed. Apart from the following historical comparison, data from all localities in the 2005 and 2006 seasons will be pooled together in order to establish these relationships.

### **Comparison of yield components in the Western Cape: Historical versus New data**

Very little data on the components of wheat yield in the Western Cape have been published, except for some work by Laubscher (1986) and Schoonwinkel *et al.* (1991). Although production practices of that time differ vastly from those used today, a comparison of yield component data over the 21 year period might give an indication of how changes in production practices influenced the different yield components. For the purposes of this comparison, the average data of only one cultivar, SST 015 in one season (2006) will be used for both the Swartland and the Southern Cape regions. SST 015 was chosen as it was the cultivar in the study most recently released and the 2006 season was chosen as it was a very good rainfall season in the Swartland and a fair season in the Southern Cape. While SST 015 is a very good example of a modern-day cultivar, newly released cultivars at the time (1985) Gamtoos and Palmiet were included in the studies of Laubscher (1986) and Schoonwinkel *et al.* (1991).

This data will be compared with typical data on producer's farms in 1985, obtained from Laubscher (1986) and experimental data collected by him in these regions, as well as data published by Schoonwinkel *et al.* (1991) for the Swartland region (Table 9.1). Laubscher and Schoonwinkel measured the yield  $\text{head}^{-1}$  in their studies, which was not measured in this study.

In order to draw a comparison, the yield  $\text{head}^{-1}$  data was calculated from yield data and head count determinations using the equation:

$$\text{Yield head}^{-1} = \text{yield m}^{-2} (\text{g}) / \text{number of heads m}^{-2}$$

Data from this study in the Southern Cape (2006) did not compare favourably with the experimental data of Laubscher for this region in 1985 (Table 9.1). The lower head population (297 vs 364 heads  $\text{m}^{-2}$ ), as well as lower yield  $\text{head}^{-1}$  figures (1.04 vs 1.51) resulted in lower grain yields (3.1 vs 3.7  $\text{ton ha}^{-1}$ ). If the 1985 producer's figures are compared with experimental data in 2006, it is interesting to note that the number of heads  $\text{m}^{-2}$  (283 and 297) and the yield  $\text{head}^{-1}$  (1.01 and 1.04) were very similar, but that the number of kernels  $\text{head}^{-1}$  (35 vs 24) and the TKM values (29 vs 44) differed

substantially. This may indicate that modern day cultivars, such as SST 015 produce fewer kernels head<sup>-1</sup> but much greater kernel weight indicated by higher TKM.

**Table 9.1** Historical and current data on yield components over a 21 year period in the Swartland and Southern Cape

	Typical	Experimental data				
	Producers	Southern Cape		Swartland		
	1985 <sup>a</sup>	1985 <sup>a</sup>	2006 <sup>c</sup>	1985 <sup>a</sup>	1987 <sup>b</sup>	2006 <sup>c</sup>
<b>Heads m<sup>-2</sup></b>	283	364	297	415	265	294
<b>Yield head<sup>-1</sup> (g)</b>	1.01	1.51	1.04	1.42	1.79	1.43
<b>Kernels head<sup>-1</sup></b>	35	42	24	39	-	35
<b>TKM (g)</b>	29	34	44	34	-	41
<b>Grain yield (ton/ha)</b>	<b>2.9<sup>d</sup></b>	<b>3.7</b>	<b>3.1</b>	<b>4.0</b>	<b>4.3</b>	<b>4.2</b>

a) Laubscher (1986), Average of cultivars including Palmiet released at the time. Broadcast planting method. Planting density, 500 seeds m<sup>-2</sup>.

b) Schoonwinkel *et al.* (1991). Cultivar Palmiet in 175 mm row widths with a planter. Average over planting densities (max 100 kg seed ha<sup>-1</sup> used) at Langgewens Research Station, Moorreesburg.

c) Present study. Average data for the cultivar SST 015 in each region over row widths (250-300 mm) and different seeding densities (max 300 seeds m<sup>-2</sup>) used.

d) Average yield components measured on producers farms in close proximity to experiments in each region in 1985. Grain yield was not measured, but calculated from yield components.

The grain yield measured in the 1985 and 1987 experiments in the Swartland averaged or exceeded 4 ton ha<sup>-1</sup> (Table 9.1) which indicates that growing conditions in these seasons favoured high yields and are probably comparable to the 2006 season (4.2 ton ha<sup>-1</sup>). Average yield calculated for producers was much lower (2.9 ton ha<sup>-1</sup>) indicating a substantial yield gap of more than one ton ha<sup>-1</sup>. The reason for this yield gap is not clear, but may have been due to lower planting densities used by producers, or management practices in general. With the use of on-farm, producer managed trials in 2006 (Chapter 3), the yield gap (although not measured) is expected to be much smaller than in 1985.

Results from the present study in the Swartland (2006) compare very favourably to producers data obtained in 1985 (Laubscher, 1986). Although the number of heads m<sup>-2</sup> (283 and 294) and the number of kernels head<sup>-1</sup> were similar (35), higher yield head<sup>-1</sup> (1.43 vs 1.01) caused by the higher TKM (41 vs 29) had a positive impact on grain yield (4.2 ton ha<sup>-1</sup>) in 2006. These results also compare well to experimental data for 1985 and 1987 (Laubscher, 1986, Schoonwinkel *et al.*, 1991) for the Swartland region. In his studies Laubscher (1986) used very high planting densities with the broadcast method to obtain very high numbers of heads m<sup>-2</sup> (415). He also measured fairly high yield head<sup>-1</sup> values (1.42 g) and high numbers of kernels head<sup>-1</sup> (39) which predicted yield levels of 5.5 ton ha<sup>-1</sup> but grain yields of only 4.0 ton ha<sup>-1</sup> was realised. Although results from this study (2006) indicated much lower head populations (294 heads m<sup>-2</sup>), somewhat higher

yield levels (4.2 ton ha<sup>-1</sup>) were achieved. Once again the higher kernel weight of the modern-day cultivar SST 015 compensated for the lower number of kernels head<sup>-1</sup>.

In 1987, which was also a high yielding season in the Swartland, Schoonwinkel (1991) measured high yields with the cultivar Palmiet planted in narrow (175 mm) rows, at fairly low planting densities of 50-100 kg seed ha<sup>-1</sup>. Although the average number of heads m<sup>-2</sup> was lower than the numbers found in the present study (265 vs 297) very high yield head<sup>-1</sup> (1.79 vs 1.43 g) resulted in slightly higher grain yield (4.3 vs 4.2 ton ha<sup>-1</sup>).

This data confirms to some extent that, wheat yield will be advantaged in some seasons in the Western Cape by high seeding rates and what is called high ratios of rectangularity by Holliday (1963), as it will reduce inter-plant competition in the row at critical growth stages during the season. However, conclusions from these comparisons must be drawn with caution as there may be many factors not taken into account, but in general it seems that grain yields achievable with the current no-till planting method is at least on par with optimum yields achieved under experimental conditions 21 years ago. This is despite the wider row widths required by the no-till system and lower planting densities currently used. However, it must be taken into account that these comparisons were based on data collected in seasons with high potential and relatively early planting dates which would have benefited tillering. If these comparisons were made for seasons when tillering and/or floret survival was limited due to drought at critical stages, another picture may have emerged. In dry seasons severe interplant competition due to the low ratios of rectangularity in these wide rows would have become a yield reducing factor as reported by Holliday (1963). Therefore the risk of yield loss due to unfavourable climatic conditions at critical stages might be higher than it was 21 years ago. If the expected lower yield gap between experimental data and producer's yields in the current data is true, this comparison might also indicate that producers are currently better off in terms of yield levels than 21 years ago. This may be due to factors like improved cultivars (for instance higher TKM produced) but also due to improved management practices like plant nutrition, weed control, soil fertility and soil water conservation created by the combination of crop rotation and the no-till planting method.

### **The relationship between plant population and grain yield**

Although high planting densities (up to 160 kg seed ha<sup>-1</sup>) were recommended by Agenbag (1992) to achieve sufficient plant establishment and head populations, yield responses to different plant populations in terms of grain yield in the present study have been very variable. In Figure 9.1 in which the combined data of all localities in 2005 and 2006 is depicted, it can be seen that seasons and localities had major influences on the yield responses measured. No real trend emerged for any particular locality in any

particular season. As discussed in Chapter 6, grain yield was significantly influenced by planting density in one Southern Cape trial (Caledon 2005) when the highest yield was produced by the lowest planting density treatment (100 target (no.) of plants  $m^{-2}$ ). From the discussion on yield response to planting density in the Swartland (Chapter 8) it can be seen that more positive responses to planting density (up to 175 target (no.) of plants  $m^{-2}$ ) were found in the majority of the trials.

In general these results indicate that excellent yields can be achieved in some seasons and localities at low planting densities and poor yields in other seasons at high planting densities. This was also the case in the studies of Anderson (1991) who observed that variations in optimum planting density between seasons were far greater than variation between cultivars in a similar Mediterranean environment.

### **The relationship between plant population and the number of heads plant<sup>-1</sup>**

The high variability of response in grain yield to different plant populations found in this study can, to a large extent, be explained by the relationship between plant population (established number of plants  $m^{-2}$ ) and the number of heads plant<sup>-1</sup> as depicted in Figure 9.2.

In Chapters 5 and 7 it was clearly shown that reduced numbers of heads plant<sup>-1</sup> resulted when planting density, and therewith plant population (number of plants per unit area), increased. The same response can also be seen if the data for different localities are pooled for different seasons and cultivars in a regression analysis. Exponential, non-linear curves ( $y = A + Br^x$ ) provide fairly good fits for these responses (Figure 9.2). The constants for these curves (A, B and r) as well as the estimated  $R^2$  values are shown in Table 9.2. It can be seen in Figure 9.2 that the lower rainfall received at most localities in 2005 (Chapter 3), resulted in a lower overall number of heads plant<sup>-1</sup> for all three cultivars. The number of heads plant<sup>-1</sup> of the cultivar SST 57 in particular, was lower than one head per plant when 200 plants  $m^{-2}$  was exceeded, which indicated that some of the plants originally counted, did not survive to become head bearing. The same cultivar produced the highest number of heads plant<sup>-1</sup> in the more favourable 2006 season. From these curves, it is clear that cultivars do not only differ in response from each other, but that the same cultivar also differs in response according to the potential of the season.



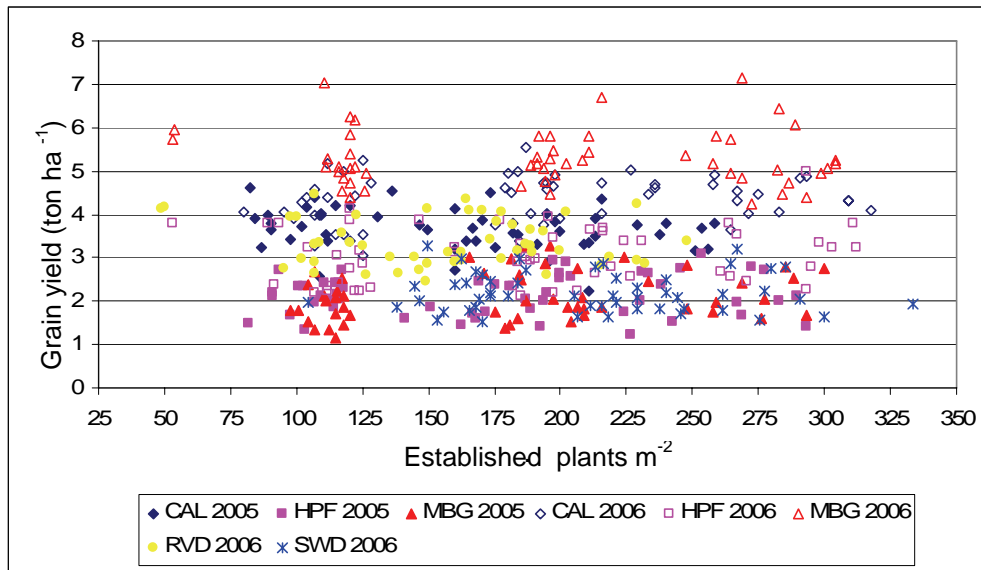

**Figure 9.1** A scatter plot indicating the relationship between established plants ( $\text{m}^{-2}$ ) and grain yield ( $\text{ton ha}^{-1}$ ) at different localities in the 2005 and 2006 seasons. CAL = Caledon. HPF = Hopefield, MBG = Moorreesburg, RVD = Riversdale and SWD = Swellendam.

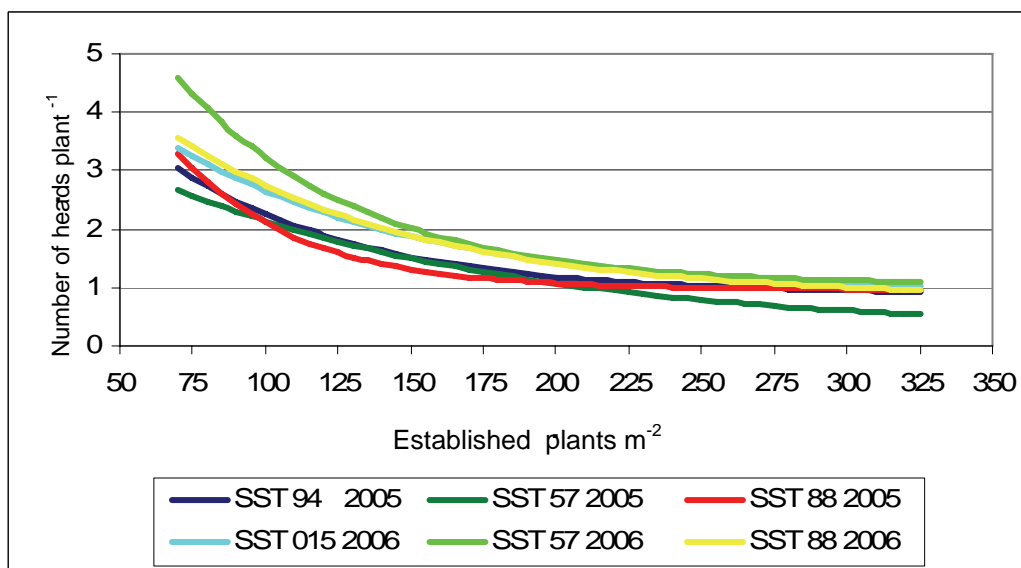

**Figure 9.2** Fitted exponential curves for the number of heads  $\text{plant}^{-1}$  against plant populations for different cultivars in 2005 and 2006.

These seasonal effects on the number of heads  $\text{plant}^{-1}$  was also clearly illustrated by the work of Anderson (1986) who found that in one season (1980-1981) tiller production at low planting densities was large, but that tiller mortality was small and that this resulted in high numbers of heads  $\text{plant}^{-1}$  and per unit area. However in the following season, when conditions that favoured tillering were followed by low rainfall during stem elongation, a loss of 21% of the tillers and a reduction in the head population was experienced. His results indicate that improvements in water supply, nutrient supply,

genotypes and grain yields were accompanied by reduced tiller mortality and the ability of plants to produce larger head populations. Anderson (1986) further suggests that the ability of plants to adjust the number of tillers that become head bearing is an important mechanism that allows the wheat crop to optimise its yield under variable seasonal conditions found in Mediterranean environments.

In general, the number of heads plant<sup>-1</sup> of all cultivars in all seasons included in this study, approached 1.0 when 250 plants m<sup>-2</sup> were exceeded (Figure 9.2). The average calculated number of heads (all cultivars) is 1.39, 1.23, 1.12 and 1.04 heads plant<sup>-1</sup> for 175, 200, 225 and 250 established plants m<sup>-2</sup> respectively (Table 9.2). This implies that on average, each plant will only produce one head (mono-culm effect) if plant populations of 250 plants m<sup>-2</sup> are exceeded and enough resources are available to sustain the population, which was not the case with SST 57 in 2005 (Figure 9.2). However, with sufficient resources available, greater plant populations (than 250 plants m<sup>-2</sup>) could be effective in increasing the number of heads per unit area, especially if the competition between plants can be kept to the minimum as was the case with the conventional system (Laubscher, 1986).

During the mid eighties, Laubscher (1986) aimed for head populations of 400 heads m<sup>-2</sup> in his experiments from 245-250 plants m<sup>-2</sup> (1.6 heads plant<sup>-1</sup>). He found that seeding densities of 500 seeds m<sup>-2</sup> (170-175 kg seed ha<sup>-1</sup>, TKM=35) were needed to achieve the desired goal, as the seedling survival rate was only 50%. To achieve similar plant populations with a seedling survival rate of 80%, only 109 kg seed ha<sup>-1</sup> of the same TKM (35g) will be needed. With the number of heads m<sup>-2</sup> approaching 1.0 when the no-till planting method is used at this plant population (Table 9.2) a maximum number of about 250-300 heads m<sup>-2</sup> can be expected. However, at a lower seeding density, say 175 established plants m<sup>-2</sup> and an average of 1.39 heads plant<sup>-1</sup>, 243 heads m<sup>-2</sup> can be expected, which compares well to the higher plant population, indicating that compensation by increased numbers of heads plant<sup>-1</sup> can be effective to maintain sufficient head populations at lower planting densities.

**Table 9.2** Non-linear exponential curves ( $y = A + Br^x$ ) fitted for the number of heads plant<sup>-1</sup> vs. number of plants m<sup>-2</sup> for different cultivars during the 2005 and 2006 season and the average number of heads plant<sup>-1</sup> calculated from 175, 200, and 225 plants m<sup>-2</sup>

Cultivar	Season	A	B	r	R <sup>2</sup> (%)	175	200	225	250
						plants m <sup>-2</sup>	plants m <sup>-2</sup>	plants m <sup>-2</sup>	plants m <sup>-2</sup>
SST 94	2005	0.881	6.260	0.9849	55.2	1.32	1.18	1.09	1.02
SST 57	2005	0.220	4.302	0.9911	78.8	1.27	1.07	0.92	0.79
SST 88	2005	0.966	12.460	0.9764	53.5	1.16	1.07	1.02	1.00
SST 57	2006	1.036	11.060	0.9840	85.5	1.69	1.47	1.32	1.23
SST 88	2006	0.827	3.640	0.9881	73.8	1.28	1.16	1.08	1.01
SST 015	2006	0.929	5.740	0.9880	65.4	1.63	1.45	1.31	1.21
<b>Average</b>						<b>1.39</b>	<b>1.23</b>	<b>1.12</b>	<b>1.04</b>

These results indicate that lower head populations are generally achieved with the no-till planting method than previously aimed for by Laubscher (1986) with the conventional planting method. Increasing row widths were seen to reduce head populations in this study (Chapters 5 and 7) and were also widely reported by Doyle (1980); Marshall and Ohm (1987); Johnson *et al.* (1988) and Schoonwinkel *et al.* (1991). All of these authors indicated that this reduction is caused by increased inter-plant competition at wider row widths which was described by Holliday (1963) and Puckridge and Donald (1967).

### The relationship between head population and grain yield

The head population (number of heads per unit area that survive to produce kernels) is considered one of the most important factors that contribute to grain yield (Satorre, 1999). Figure 9.3 clearly shows that there is an increasing trend in grain yield as the head population increases, but that variation in grain yield also increases at higher head populations.

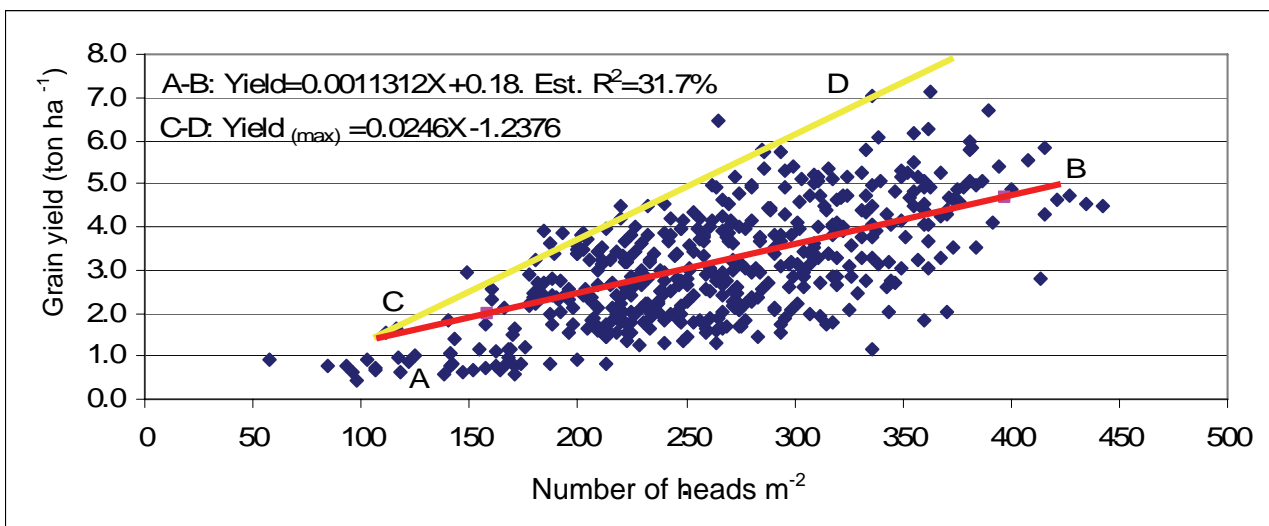

**Figure 9.3** The relationship between head population (number of heads  $m^{-2}$ ) and grain yield ( $ton\ ha^{-1}$ ) at all localities (Riversdale, Swellendam, Caledon, Moorreesburg and Hopefield) during the 2005 and 2006 seasons.

If a simple linear regression (red line A-B) is fitted to this data, only 31.7% of the variation is accounted for. The equation for this line is as follows:

$$\text{Yield (ton/ha}^{-1}\text{)} = 0.0011312x + 0.18, \quad R^2 = 31.7\%$$

$$x = \text{number of heads } m^{-2}$$

Variation in this dataset would have been caused by many factors that could have influenced the relationship, such as climatic conditions (different localities and seasons),

cultivars, plant populations and row widths included. As all these factors may influence producers differently in every season, it is impossible to develop an accurate model with which yield can be predicted from any given head population, that will be true for a wide set of circumstances. However, the hand drawn yellow line (C-D) may be of some value in determining the maximum yield (Yield<sub>(max)</sub>) that has been achieved in this study at given head populations. The equation of this line was calculated with simple mathematics to be:

$$\text{Yield}_{(max)} (\text{ton/ha}^{-1}) = 0.0246x - 1.2376$$

x = number of heads m<sup>-2</sup>

The maximum yield (Yield<sub>(max)</sub>) which was achieved in this study according to this equation at different head populations is shown in Table 9.3.

**Table 9.3** Yield<sub>(max)</sub> values for this study calculated with Yield<sub>(max)</sub> = 0.0246x - 1.2376 at different head populations

Head population (heads m <sup>-2</sup> )	Yield <sub>(max)</sub> (ton ha <sup>-1</sup> )
150	2.452
175	3.067
200	3.682
225	4.297
250	4.912
275	5.527
300	6.142
350	7.372

Table 9.3 shows that maximum yields of not more than 2,452 ton ha<sup>-1</sup> were achieved with low head populations of 150 heads m<sup>-2</sup>. In the range of 250-300 heads m<sup>-2</sup>, it was possible to achieve yield levels of 4.912 to 6.124 ton ha<sup>-1</sup>. According to these calculations, to have achieved very high yield levels (above 7 ton ha<sup>-1</sup>) more than 350 heads m<sup>-2</sup> would have been needed, but such yield levels were only achieved in a few single plots (Figure 9.3). This figure also indicates that when high head populations in the region of 400 heads m<sup>-2</sup> were achieved (as aimed for by Laubsher, 1986), the yields realised, were not as high as would be expected. This is most probably due to the high levels of inter-plant competition created by wide row widths at such high head populations (large sink) and not enough resources available (limited source) to reach the full potential created by the large number of heads.

## Planting density recommendations

The trial design used in the study (factorial experiments including row widths and planting densities) has limitations in terms of planting density recommendations, as only three planting density treatments were used in each experiment. In order to determine optimum planting densities with the no-till planting method, a wider range of planting densities would have produced more specific results. However, analysis of the yield components above does give some indicators which can be used to make preliminary recommendations. From the discussion above it is clear that with the no-till planting method head populations of 250-300 heads  $m^{-2}$  are sufficient to create a yield potential (Yield<sub>(max)</sub>) of between 4.9 and 6.1 ton  $ha^{-1}$ . Such high yields in commercial fields will only be achievable in the most excellent of seasons when almost no drought stress occurs at any time during the season and all management practices are optimal. To achieve such head populations, at least 175 established plants  $m^{-2}$  will be needed (175 plants  $m^{-2}$  x 1.39 heads  $plant^{-1}$  = 243 heads  $m^{-2}$ ).

To ensure at least 175 established plants  $m^{-2}$ , at an 80% seedling survival (Chapter 4), 25% more seeds (219 seeds  $m^{-2}$ ) must be placed by the planter (see planting density calculations in Chapter 3). At a very low TKM of 32 g, 70 kg of seed  $ha^{-1}$  will be required and with a high TKM of 40 g, 87.5 kg seed  $ha^{-1}$  will be required. These planting density requirements are somewhat lower than recommended by the owners of current cultivars, which range from 100-140 kg seed  $ha^{-1}$ . If it is taken into account that the recommendations by cultivar owners are made for conventional planting methods where seedling survival can be very low (50-70%) and that wheat is planted with a large variety of planters, it is understandable that a large safety factor is built into the recommendations. Producers that adapt planting densities downwards when using the no-till planting method do so at own risk and must ensure that the planter is accurately set-up and calibrated, soil moisture conditions are favourable and that the crop is established well within the recommended planting time.

### **Final recommendations from this study**

Wider row widths used with the no-till planting method (250-300 mm) are necessary for stubble handling, but should be kept to a practical minimum to limit inter-plant competition as far as possible. This increased inter-plant competition will reduce head populations in most seasons, which in turn can reduce grain yield if compensation by increased kernels head<sup>-1</sup> do not realise during the season. When making decisions on which row width to use, this risk should be weighed against the advantages gained by using wide row widths.

Under ideal conditions that favour seedling survival, tillering and survival of head bearing tillers and florets, this study indicated that excellent yields can be produced at low planting densities. This is due to compensation for reduced plant populations by increased numbers of heads plant<sup>-1</sup> in ideal conditions. Planting densities used with the no-till planting method, should however be lowered with caution and a target of at least 175 established plants m<sup>-2</sup> must be reached to ensure sufficient yield potential by creating in the region of 250 heads m<sup>-2</sup> or more. It must be kept in mind that unknown risks like insect or pre-emergence herbicide damage may effect seedling survival negatively and cause insufficient stand, the effect of which will be worse if very low planting densities are used. Relatively high plant populations in the row are also beneficial in terms of competition with weeds (especially herbicide resistant ryegrass) in the row, which is not controlled by pre-emergence herbicides. Reduced planting densities should be adapted upwards when the planting date is postponed or any other circumstance occurs that may reduce the tillering ability of the crop.

The use of very high planting densities such as 160 kg seed ha<sup>-1</sup>, as recommended in the past by Agenbag (1992), may be wasteful as the competition threshold may be exceeded in the wide rows and no yield benefit will be derived from it. It is however recommended that further research, which includes a wider range of planting densities, is done in order to determine optimal planting densities for the no-till planting method for specific production regions.

## SUMMARY

The adoption of conservation tillage and therewith the no-till planting method, brought two fundamental changes to the way the wheat crop is established in the Mediterranean climate of the Western Cape. The first of these is that the row widths used have to increase from the normal narrow rows (170-180 mm) to at least 250 mm to allow for sufficient stubble handling during the planting process. Secondly, the new generation of planters are designed to place seed accurately in the soil at uniform depth, which increases the probability of obtaining higher seedling survival rates than with previous planting methods (50-70%). Literature indicates that the reduction in rectangularity when wide row widths are used, will increase inter-plant competition due to increased crowding in the row, which in turn leads to reduced tillering and/or survival of head bearing tillers. Subsequently the number of heads per unit area may be reduced, which will affect grain yield, especially if resources (water and nutrients) become limited during critical growth stages in the life cycle of the crop.

The possibility of increased seedling survival rates on the one hand and the increased competition created by the wider row widths on the other, posed questions on whether current planting density recommendations should be adapted for the no-till planting method. The main objective of this study was to determine the influence of the use of wide row widths on the components of yield, grain yield itself and grain quality parameters. The second objective was to revisit planting density recommendations to be used with the no-till planting method.

The crop management decisions on row widths and planting densities are made prior to the start of the planting season and are difficult to change once the planting season has commenced. While planting density can be easily controlled, no-till planters are currently built with 250, 275 or 300 mm row spacing. In addition to the risk of reduction in heads per unit area, wide rows can also reduce the crop's ability to compete with weeds in the inter-row and cause problems during the pick-up process if the crop is swathed. Wider row widths are however very cost effective as less energy is required, planting speed is increased and capital outlay is reduced. Current planting density recommendations for most cultivars used in the Western Cape are 100-140 kg seed ha<sup>-1</sup> or least 200 to 230 established plants m<sup>-2</sup>.

Data from on-farm, producer managed trials which included cultivars, row widths and planting density treatments were used for this study. These trials were planted at Riversdale, Swellendam and Caledon in the Southern Cape region and at Moorreesburg and Hopefield in the Swartland during the 2004 to 2006 production seasons. All trials

were factorial with split-split plot designs, which were laid out in randomised complete blocks. Grain yield ( $\text{ton ha}^{-1}$ ), grain protein (%) and hectolitre mass (HLM) were determined to study the effect of the changes in row width and planting density on the yield and quality parameters of the different cultivars. In order to explain the grain yield responses found in 2004, detailed yield components, namely seedlings  $\text{m}^{-2}$ , seedling survival (%), number of heads  $\text{m}^{-2}$ , number of heads  $\text{plant}^{-1}$ , number of kernels  $\text{head}^{-1}$  and kernel weight (TKM) were determined at all sites in 2005 and 2006.

The seedling survival rate was determined on all treatments by counting emerged seedlings three to four weeks after planting. Seedling numbers  $\text{m}^{-2}$  increased with increasing planting density treatments, indicating that planting densities were effectively applied by the planter. Seedling numbers  $\text{m}^{-2}$  decreased as a result of increased row widths at some localities like Swellendam in 2005 and Riversdale in 2006. At other localities like Caledon and Moorreesburg in 2006 these decreases were only true for the higher planting densities, while no reduction was found at Swellendam in 2006. In spite of the abovementioned decreases in seedling survival due to increased planting densities and row widths, survival of 80% was easily achieved in all trials with the exception of Caledon and Swellendam in 2005. No-till planting methods and seeding equipment may for this reason be efficient to improve on the often low and variable seedling survival rates (50-70%), found with the conventional planting methods.

The components of yield, number of heads  $\text{m}^{-2}$ , number of heads  $\text{plant}^{-1}$ , number of kernels  $\text{head}^{-1}$  and kernel weight were affected by changes in row widths and planting density in this study. However, the responses depended to a very large extent on climatic factors during the season, but may also have been affected by factors such as soil fertility and water holding capacity of soils. The response of yield components of the different cultivars used was mostly similar (no interactions) but cultivars did respond differently with regards to the number of heads  $\text{plant}^{-1}$  due to row widths and planting density (CV x RW and CV x PD) at Swellendam in 2005 and to the number of kernels  $\text{head}^{-1}$  in a three way interaction (CV x RW x PD) at the same locality in 2006. The yield component response that raises the most concern is the clear trend of reduction in the number of heads  $\text{m}^{-2}$  as row widths increase, which was significant in eight out of the nine experiments presented. These findings are supported by many similar reports in literature, including comparable Mediterranean environments. Therefore the risk of reduced number of heads  $\text{m}^{-2}$  due to wide row widths could not be excluded by this study and will occur in most seasons in the Western Cape.

The second important response is the inverse relationship between the number of heads  $\text{plant}^{-1}$  which decreased significantly as planting density increased in all nine trials. This



inverse relationship is due to increased tiller mortality per plant as plant populations (and therefore the competition between plants) increases. At lower planting densities, the competition between individual plants is less severe and more tillers survive, which then compensates to some extent for reductions in plant population. However, increased plant populations (by increasing planting densities) have been effective in increasing the number of heads per unit area in most cases in this study.

The grain yield response of cultivars differed as could be expected, because cultivars are adapted to specific growing conditions which differ from season to season and locality to locality. In this study, cultivars responded similarly to the factors row width and planting density as indicated by the lack of interactions in twelve out of the fourteen experiments. The only two exceptions were found in the Swartland during the 2004 season, when establishment of the crop was delayed due to late spring rains and cultivars responded differently in interactions to planting density (PD x CV) at Moorreesburg and to both factors (PD x RW x CV) at Hopefield, most probably as a result of the shorter growth period and/or the reduced tillering potential when the crop was planted late.

Differences found with regard to the quality parameters, grain protein (%) and hectolitre mass in this study, were to a very large extent the result of different genotypic variation. Although cultivar responses were affected by increased row widths or planting densities, these effects were mostly negligible and would not have had a significant influence on how the grain would have been graded.

The use of wider row widths (300 mm vs 250 mm) did not always result in negative yield responses, but significant yield losses did occur in six out of the fourteen trials presented here (Swellendam 2006, Caledon 2004 and 2006, Moorreesburg 2004 and Hopefield 2004 and 2006). Reductions in grain yield occurred in three out of eight trials in the Southern Cape and in three out of six trials in the Swartland. While significant yield reduction due to wider row widths varied between 7.1% and 10.9 % in the Southern Cape, it varied between 6.8% and 33.7% for 250 mm increased to 300 mm row widths in the Swartland. Grain yield of the cultivar SST 94 at the widest row width of 350 mm was reduced with 42.8% when compared to the 250 mm row width. These results indicate that the Swartland region is most likely more sensitive to increasing row widths than the Southern Cape region. Yield reductions due to widening row widths can be linked to reductions in head per unit area and the inability of the crop to compensate (by increasing the number of kernels head<sup>-1</sup> or kernel weight) when constraints like water shortage occur during the growing season. The risk of yield loss due to wide row widths

could not be excluded by this study and the row widths should remain as narrow as practically possible to limit this risk.

The response in grain yield to increasing planting density differed between these two regions as no significant positive responses were found in the Southern Cape trials, but significant yield increases were found in four out of the six Swartland trials, indicating that planting density was an important yield determining factor in this region. No significant yield benefits were found in any of these trials if planting densities were increased above the target of 175 plants  $m^{-2}$ . Regression analysis indicated that if this target plant population is reached, in the order of 243 or more heads  $m^{-2}$  can be expected which seems sufficient to produce grain yields of in the region of 5 ton  $ha^{-1}$ . To ensure at least 175 established plants  $m^{-2}$ , at an 80% seedling survival, 25% more seeds (219 seeds  $m^{-2}$ ) must be placed by the planter. This will require a planting density of 70 kg seed  $ha^{-1}$  for seed with a low TKM (32 g) up to 87.5 kg seed  $ha^{-1}$  for seed with high TKM (40g). These planting density requirements are somewhat lower than recommended by the owners of current cultivars, which range from 100 to 140 kg seed  $ha^{-1}$ . Deviation from the recommended planting densities should only be undertaken if conditions at planting time are conducive for high seedling survival rates (above 80%) and the crop is established well within its recommended planting time.

## REFERENCES

- AMERICAN ASSOCIATION OF CEREAL CHEMISTS, 2000a. Near-Infrared Reflectance method for protein determination in wheat flour AACC Method 39-11. *In: Approved methods of the American Association of Cereal Chemists*, 10<sup>th</sup> ed. Vol I.
- AMERICAN ASSOCIATION OF CEREAL CHEMISTS, 2000b. Test weight per bushel. AACC method 55-10. *In: Approved methods of the American Association of Cereal Chemists*, 10<sup>th</sup> ed. Vol II.
- ACEVEDO, E.H., SILVA, P.C., SILVA, H.R. & SOLAR, B.R., 1999. Wheat production in Mediterranean environments. *In: E.H. Satorre & G.A. Slafer (ed.). Wheat ecology and physiology of yield determination*. Food Products Press, an imprint of the Haworth Press, Binghamton, N.Y. 141-159.
- AGENBAG, G.A., 1992. Saaidigtheid van koring – Samevatting van Navorsingsresultate. *Koörd. van Kleingraannavorsing en ontwikkeling in die Winterreënstreek*. 8, 99-100.
- AGENBAG, G.A. & MAREE, P.C.J., 1989. Effect of tillage on soil carbon, nitrogen and soil strength of simulated surface crusts in two cropping systems for wheat (*Triticum aestivum*). *Soil & Tillage Res.* 14, 53-65.
- AGENBAG, G.A. & MAREE, P.C.J., 1991. The effect of tillage on some soil properties, plant development and yield of spring wheat (*Triticum aestivum*) in stony soil. *Soil & Tillage Res.* 21, 97-112.
- AMJAD, M. & ANDERSON, W.K., 2006. Managing yield reductions from wide row spacing in wheat. *Aust. J. Exp. Agric.* 46, 1313-1321.
- ANDERSON, W.K., 1986. Some relationships between plant population, yield components and grain yield of wheat in a Mediterranean environment. *Aust. J. Agric. Res.* 37, 219-233.
- ANDERSON, W.K. & BARCLAY, J., 1991. Evidence for differences between three wheat cultivars in yield response to plant population. *Aust J. Agric. Res.* 42, 701-713.
- ANDERSON, W.K. & IMPIGLIA, A., 2002. Management of dryland wheat. *In: B.C. Curtis, S. Rajaram & H. Gómez Macpherson (eds.). Bread wheat: improvement and production*. Food and Agriculture Organization of the United Nations, Rome.
- ANDERSON, W.K., SHARMA, D.L., SHACKLEY, B.J. & D'ANTUONO, M.F., 2004. Rainfall, sowing time, soil type, and cultivar influence optimum plant population for wheat in Western Australia. *Aust. J. Agric. Res.* 55, 921-930.

- ANDRADE, D.S., COLOZZI-FILHO, A. & GILLER, K.E., 2003. The soil microbial community and soil tillage. *In* A.E. Titi (ed.). Soil tillage in agro-ecosystems. CRC Press New York. 51-81.
- ANDREINI, M., 2002. Conserving soil water will conserve crop yield. *In*: S. Wallwork (ed.). Min till drill: A guide to minimum tillage cropping systems. Kondinin Group, Cloverdale, Western Australia. 78-79
- ARC-SMALL GRAIN INSTITUTE, 2007. Guidelines: Production of small grains in the winter rainfall region. Agricultural Research Council, Pretoria.
- BAKER, C.J., SAXTON, K.E. & RITCHIE, W.R., 1996. *No-till seeding: Science and Practice*. CABI Publishing, Wallingford, UK.
- BLACKSHAW, R., 2002. No-tillage brings profits to Western Canada. *In*: S. Wallwork (ed.). Min till drill: A guide to minimum tillage cropping systems. Kondinin Group, Cloverdale, Western Australia. 39-40
- BONAVENTURE, A.B., HAQUE, A., TOLMAY, J.P.C., KHALMANOV, B.A., REDDY, P.V. & CALDERÓN, W. A., 2000. Towards sustainable agricultural development: Research and development options for improved integrated water management for agriculture in the Upper East Region of Ghana. *Working document series 85 – Ghana 2000*. International Centre for development orientated Research in Agriculture (ICRA), Wageningen, Netherlands.
- BRENNAN, J. & WALLWORK, S., 2002. Systematic approach brings long-term goals. *In*: S. Wallwork (ed.). Min till drill: A guide to minimum tillage cropping systems. Kondinin Group, Cloverdale, Western Australia. 44-50.
- BRIGGS, K.G. & AYTENFISU, 1979. The effects of seeding rate, seeding date and location on grain yield, maturity, protein percentage and protein yield of some spring wheats in central Alberta. *Can. J. Plant Sci.* 59, 1139-1145.
- BUCKLEY, D., 2002. Soil health an issue when considering livestock. *In*: S. Wallwork (ed.). Min till drill: A guide to minimum tillage cropping systems. Kondinin Group, Cloverdale, Western Australia. 93-96.
- BURCH, R.N. & PERRY, M.W., 1986, Row spacing and cereal crop yield. *J. Agric. W. Aust.* 27, 103-106.
- CARR, P.M., HORSLEY, R.D. & POLAND, W.W., 2003. Tillage and seeding rate effects on wheat cultivars: II. Yield components. *Crop Sci.* 43, 210-218.
- CHAN, Y. & HEENAN, D., 2002. Conservation farming lifts soil organic matter. *In*: S. Wallwork (ed.). Min till drill: A guide to minimum tillage cropping systems. Kondinin Group, Cloverdale, Western Australia. 88-90.
- CIHA, A.J., 1982. Yield and yield components of four spring wheat cultivars grown under three tillage systems. *Agron. J.* 74, 317-320.

- CIHA, A.J., 1983. Seeding rate and seeding date effects on spring seeded small grain cultivars. *Agron. J.* 75, 795-799.
- CRABTREE, B. & BIRCH, P., 2002. Diverse rotations suit minimum tillage systems. *In*: S. Wallwork (ed.). *Min till drill: A guide to minimum tillage cropping systems*. Kondinin Group, Cloverdale, Western Australia. 136-141.
- CRABTREE, R.J. & RUPP, R.N., 1980. Double and monocropped wheat and soyabeans under different tillage and row spacings. *Agron. J.*, 72, 445-448.
- DECKARD, E.L., TSAI, C.Y. & TUCKER, T.C., 1984. Effect of nitrogen nutrition of agronomic crops. *In*: R.D. Hauck (Ed.) *Nitrogen in crop production*. ASA-CSSA-SSA Publishers, Madison, WI USA.
- DEL CIMA, R., D'ANTUONO, M.F. & ANDERSON, W.K., 2004. The effects of soil type and seasonal rainfall on the optimum seed rate for wheat in Western Australia. *Aust. J. Exp. Agric* 44, 585-594.
- DERKSON, D., 2002. No-tillage weed control is a balancing act. *In*: S. Wallwork (ed.). *Min till drill: A guide to minimum tillage cropping systems*. Kondinin Group, Cloverdale, Western Australia. 68-74.
- DOYLE, A.D., 1980. The effect of row spacing on wheat yield. *J. Aust. Inst. Agric. Sci.* 125-127.
- DOYLE, R., 1988. Closer spaced rows and type of machinery. *J. Agric. W. Aust.* 29 17-19.
- FERTILIZER SOCIETY OF SOUTH AFRICA, 2003. *FSSA Fertiliser Handbook*. 5th edn. Fert. Soc. S. Afr., P.O. Box 75510, Lynnwood Ridge, Pretoria 0040. 202-208.
- FOUCHE, P. & SCHOONWINKEL, M.L., 1991. Korrekte saaidigheid vir koringverbouing. *Elsenburg Joernaal* (Spes. Uitgawe: Gewasproduksie).
- FRANZLUEBBERS, A.J., 2004. Tillage and residue management effects on soil organic matter. *In* F. Magnoff & R.R. Weil (eds.). *Soil organic matter in sustainable agriculture*. CRC Press, New York. 227-268.
- FREDERICK, J.R. & BAUER, P.J., 1999. Physiological and numerical components of wheat yield. *In*: E.H. Satorre & G.A. Slafer (ed.). *Wheat ecology and physiology of yield determination*. Food Products Press, an imprint of the Hayworth Press, Binghamton, N.Y. 45-65.
- FREDERICK, J.R. & MARSHALL, G.C., 1985. Grain yield and yield components of soft red winter wheat as affected by management practices. *Agron. J.* 77, 495-499.
- GIUMELLI, J., KELLY, P. & SLATTERY, M., 2002. Take time with tine selection and setup. *In*: S. Wallwork (ed.). *Min till drill: A guide to minimum tillage cropping systems*. Kondinin Group, Cloverdale, Western Australia. 249-253.

- HEENAN, D. & CONYERS, M., 2002 Lime a solution to no-till acidification. *In: S. Wallwork (ed.). Min till drill: A guide to minimum tillage cropping systems.* Kondinin Group, Cloverdale, Western Australia. 117-119.
- HILTBRUNNER, J., LIEDGENS, M., STAMP, P. & STREIT, B., 2005. Effects of row spacing and liquid manure on directly drilled winter wheat in organic farming. *Europ. J. Agronomy* 22, 441-447.
- HOLLIDAY, R., 1963. The effect of row width on the yield of cereals. *Field Crop Abstr.* 16, 71-81.
- JOHNSON, J.W., HARGROVE, W.L. & MOSS, R.B., 1988. Optimizing row spacing and seeding rate for soft red winter wheat. *Agron. J.* 80, 164-166.
- KIRKEGAARD, J.A., 1995. A review of trends in wheat yield responses to conservation cropping in Australia. *Aust. J. Exp. Agric.* 35, 835-848.
- LAFOND, G.P., 1994. Effects of row spacing, seeding rate and nitrogen on yield of barley and wheat under zero-till management. *Can. J. Plant Sci.* 74, 703-711.
- LAFOND, G.P. & GAN, Y., 1999. Row spacing and seeding rate studies in no-till winter wheat for the Northern Great Plains. *J. Prod. Agric.*, 12, 624-629.
- LAUBSCHER, E.W., 1986. Sleutel tot goeie koringoes per hektaar. Deur Irma Smit, *Landbouweekblad*, 2 May 1986, 6-8.
- LAUBSCHER, E.W., MAREE, P.C. & AGENBAG, G.A., 1991. Die uitwerking van saaidigtheid op lentekoringkultivars. *Koörd. van Kleingraanavorsing en ontwikkeling in die Winterreënstreek.* 7, 98-103.
- LITHOURGIDIS, A.S., DHIMA, K.V., DAMALAS, C.A., VASILAKOGLU, I.B. & ELEFTHEROHORINOS, I.G., 2006. Tillage effects on wheat emergence and yield at varying seeding rates and on labour and fuel consumption. *Crop Sci.* 46, 1187-1192.
- LOSS, S.P. & SIDDIQUE, K.H.M., 1994. Morphological and physiological traits associated with wheat yield increases in Mediterranean environments. *Advances in Agronomy.* 52, 229-276.
- MAALI S.H., 2003. Biomass production, yield and quality response of spring wheat to soil tillage, crop rotation and nitrogen fertilisation in the Swartland wheat producing area of South Africa. Ph.D. (Agric) Dissertation, University of Stellenbosh, South Africa.
- MAALI, S.H. & AGENBAG G.A., 2004. Effect of soil tillage, crop rotation and nitrogen application rates on plant-N content of spring wheat (*Triticum aestivum*) in the Swartland wheat producing area of the Republic of South Africa. *S. Afr. J. Plant Soil* 21, 255-265.

- MALINDA, D. & WALLWORK, S., 2002. Stubble and minimum tillage stop soil erosion. *In: S. Wallwork (ed.). Min till drill: A guide to minimum tillage cropping systems.* Kondinin Group, Cloverdale, Western Australia. 99-102.
- MARSHALL, G.C. & OHM, H.W., 1987. Yield responses of 16 winter wheat cultivars to row spacing and seeding rate. *Agron. J.*, 79, 1027-1030.
- McLEOD, J.G., CAMPBELL, C.A., GAN, Y, DYCK, F.B. & VERA, C.L., 1996. Seeding depth, rate and row spacing of winter wheat grown on stubble and chemical fallow in semiarid prairies. *Can. J. Plant Sci.* 76, 207-214.
- MINKEY, D. & WALKER, S., 2002. Weed Control critical in conservation farming *In: S. Wallwork (ed.). Min till drill: A guide to minimum tillage cropping systems.* Kondinin Group, Cloverdale, Western Australia. 179-182.
- MIRALLES, D.J. & SLAFER, G.A., 1999. Wheat development. *In: E.H. Satorre & G.A. Slafer (ed.). Wheat ecology and physiology of yield determination.* Food Products Press, an imprint of the Haworth Press, Binghamton, N.Y. 13-44
- MURPHY, B., 2002. Taking care of soil benefits crops. *In: S. Wallwork (ed.). Min till drill: A guide to minimum tillage cropping systems.* Kondinin Group, Cloverdale, Western Australia. 68-74.
- NDA website, 2007. First production forecast for summer crops (2006/07) and final production estimate for winter cereals (2006). National Department of Agriculture, South Africa, <http://www.nda.agric.za>. Food security statistics (accessed October 2007).
- NEWTON, P., 2002. Evaluation secures conservation farming future. *In: S. Wallwork (ed.). Min till drill: A guide to minimum tillage cropping systems.* Kondinin Group, Cloverdale, Western Australia. 36-38.
- PAYNE, R.W., MURRAY, D.A., HARDING, S.A., BAIRD, D.B. & SOUTAR, D.M., 2006. *GenStat for Windows*, 9th edn. VSN International, Hemel Hempstead.
- PEIRETTI, R., 2007. A global need for a sustainable agricultural model. *In: H.T. Buck, J.E. Nisi & N. Salomón (eds.). Wheat production in stressed environments: Proceedings of the 7<sup>th</sup> International Wheat conference, Mar del Plata, Argentina.* 1-7.
- PRATLEY, J., 2002. Allelopathy can improve crop establishment. *In: S. Wallwork (ed.). Min till drill: A guide to minimum tillage cropping systems.* Kondinin Group, Cloverdale, Western Australia. 177.
- PUCKRIDGE, D.W. & DONALD, C.M., 1967. Competition among wheat plants sown in a wide range of densities. *Aust. J. Agric. Res.* 18, 193-211.
- PURVIS, C.E., 1990. Differential response of wheat to retained crop stubbles. I. Effect of stubble type and degree of composition. *Aust J. Agric. Res.* 4, 225-242.

- RADFORD, B. & CHUDLEIGH, F., 2002. Trial shows conservation tillage boosts profits. *In: S. Wallwork (ed.). Min till drill: A guide to minimum tillage cropping systems.* Kondinin Group, Cloverdale, Western Australia. 59-64.
- RAINBOW, R., 2002. Fertiliser placement can effect yield. *In: S. Wallwork (ed.). Min till drill: A guide to minimum tillage cropping systems.* Kondinin Group, Cloverdale, Western Australia. 156-157.
- REEDER, R., 2002. United States proves minimum tillage benefits. *In: S. Wallwork (ed.). Min till drill: A guide to minimum tillage cropping systems.* Kondinin Group, Cloverdale, Western Australia. 41-43.
- RICKERT, K.G., SEDGLEY, R.H. & STERN W.R., 1987. Environmental response of spring wheat in the south-western Australian wheat belt. *Aust. J. Agric. Res* 38, 655-670.
- ROPER, M. & GUPTA, V., 2002. Less tillage and more stubble boost soil biology. *In: S. Wallwork (ed.). Min till drill: A guide to minimum tillage cropping systems.* Kondinin Group, Cloverdale, Western Australia. 75-77.
- SATORRE, E.H., 1999. Plant density and distribution as modifiers of growth and yield. *In: E.H. Satorre & G.A. Slafer (ed.). Wheat ecology and physiology of yield determination.* Food Products Press, an imprint of the Hayworth Press, Binghamton, N.Y. 141-159.
- SCHOONWINKEL, P., AGENBAG, G.A. & CAPATOS, D., 1991. Invloed van ryspasiëring op die opbrengs van koring in die Swartland. *Appl. Plant Sci.* 5, 21-24.
- SHACKLEY, B.J. & ANDERSON, 1995. Response of wheat cultivars to time of sowing in the southern wheatbelt of Western Australia. *Aust. J. Exp. Agric.* 35, 579-587.
- SHACKLEY, B.J., ANDERSON, W.K., HOYLE, F.C. & ARMSTRONG L., 2000. The Wheat Book. Bulletin 4443, Agriculture Western Australia, Perth.
- SLAFER, G.A., 2007. Physiology of determination of major wheat yield components. *In: H.T. Buck, J.E. Nisi & N. Salomón (eds.). Wheat production in stressed environments: Proceedings of the 7<sup>th</sup> International Wheat conference, Mar del Plata, Argentina.* 557-565.
- SLAFER, G.A., ARAUS, J.L. & RICHARDS, R.A., 2002. Physiological traits that increase the yield potential of wheat. *In: E.H. Satorre & G.A. Slafer (ed.). Wheat ecology and physiology of yield determination.* Food Products Press, an imprint of the Hayworth Press, Binghamton, N.Y. 379-415.
- SMIT, H.A., VISSER, P.A. & POTGIETER, H.L., 1991. Die bepaling van optimum plantdigtheid in kleingrane in die Winterreëng gebied. *Koörd. van Kleingraannavorsing en ontwikkeling in die Winterreënstreek* 7, 110-116.



- SOIL CLASSIFICATION WORKING GROUP, 1991. Soil Classification: a taxonomic system for South Africa. Memoirs on the Agricultural Natural Resources of South Africa No 15, Department of Agricultural Development, Pretoria.
- STORRIE, A., 2002 Resistance threat requires intergrated solutions. *In: S. Wallwork (ed.). Min till drill: A guide to mimumum tillage cropping systems.* Kondinin Group, Cloverdale, Western Australia. 75-77.
- SCHWARTE, A.J., GIBSON, L.R., KARLEN, D.L., DIXON, P.M., LIEBMAN, M., JANNINK, J.-L, 2006. Planting date effects on winter triticales grain yield and yield components. *Crop Sci.* 46, 1218-1224.
- THE NON-AFFILIATED SOIL ANALYSIS WORKING COMMITTEE, 1990. Handbook of standard soil testing methods for advisory puposes. Soil Sci. Soc. S. Afr., Pretoria.
- TOLMAY, V.L., VAN LILL, D. & SMITH M.F., 1997. The influence of Demeton-S-methyl/Parathion and Imidacloprid on the yield and quality of Russian wheat aphid resistant and susceptable cultivars. *S. Afr. J. Plant Soil* 14, 107-111.
- TRIBE, G.D., 2007. What organism is responsible for the losses of canola seedlings at establishment in the Southern Cape. *Canolafokus.* No 33.
- VAN NIEKERK, H.A., 2001. Southern Africa Wheat Pool. *In: A.P. Bonjean & W.J. Angus (eds.). The World Wheat Book: The History of Wheat Breeding.* Lavoisier Publishing, Paris.
- WALLWORK, S., 2002a. Systems approach secures min-till success. *In: S. Wallwork (ed.). Min till drill: A guide to minimum tillage cropping systems.* Kondinin Group, Cloverdale, Western Australia. 4-9
- WALLWORK, S., 2002b. Wide rows risk yields but have long-term benefits *In: S. Wallwork (ed.). Min till drill: A guide to minimum tillage cropping systems.* Kondinin Group, Cloverdale, Western Australia. 163-164
- WALLWORK, S., 2002c. Integrated approuch controls problem pests: *In: S. Wallwork (ed.). Min till drill: A guide to minimum tillage cropping systems.* Kondinin Group, Cloverdale, Western Australia. 220-228.
- WALLWORK, S. & EARLY R., 2002. Manage residues for longterm productivity. *In: S. Wallwork (ed.). Min till drill: A guide to mimumum tillage cropping systems.* Kondinin Group, Cloverdale, Western Australia. 230-239.
- WALLWORK, S. & HEENAN D., 2002. Manage crops carefully to maximise growth. *In: S. Wallwork (ed.). Min till drill: A guide to mimumum tillage cropping systems.* Kondinin Group, Cloverdale, Western Australia. 166-168.
- WANDER, W., 2004. Soil organic matter fractions and their relevance to soil function. *In F. Magdoff & R.R. Weil (eds.). Soil organic matter in sustainable agriculture.* CRC Press, New York. 67-10.

YUNUSA, I.A.M., BELFORD, R.K., TENNENT,D. & SEDGLEY, R.H., 1993. Row spacing fails to modify soil evaporation and grain yield in spring wheat in a dry Mediterranean environment. *Aust. J. Agric. Res.*, 44, 661-676.

**APPENDIX A TO E**  
**MORPHOLOGICAL AND PHYSIOLOGICAL RESPONSES OF**  
**SPRING WHEAT (*Triticum aestivum* L.)**  
**TO SPATIAL ARRANGEMENTS**

John Peter Cleggenett Tolmay

Dissertation presented for the Degree Doctor of Philosophy (Agriculture)  
at Stellenbosch University



Promoter: Prof. G.A. Agenbag



November 2008

**Please use reference numbers (e.g. A-1) provided for each dataset  
in Chapters 4-8 as reference to search for a particular set of data in  
the Appendix.**

**Click on the reference number in the bookmark, and it will take you  
directly to the dataset.**

**COPYRIGHT AND INTELLECTUAL PROPERTY OF ALL DATA PRESENTED HERE  
BELONGS TO STELLENBOSCH UNIVERSITY AND THE ARC AND MAY NOT BE  
CITED, USED, RE-INTERPRETED, PRESENTED, REPRODUCED OR DISTRIBUTED  
WITHOUT THE PERMISSION OF STELLENBOSCH UNIVERSITY AND THE ARC.**

**CVxRWxPD Swellendam 2005  
Seedling Number (Plants m<sup>-2</sup>)**

**A-1**

**Analysis of variance**

Source of variation	d.f.	s.s.	m.s.	v.r.	F pr.
<b>Rep stratum</b>	2	2230.5	1115.3	1.29	
<b>Rep.CV stratum</b>					
CV	1	1009.8	1009.8	1.17	0.393
Residual	2	1727.8	863.9	5.64	
<b>Rep.CV.RW stratum</b>					
RW	1	1570.5	1570.5	10.26	<b>0.033*</b>
CV.RW	1	2.4	2.4	0.02	0.906
Residual	4	612.2	153.0	0.40	
<b>Rep.CV.RW.PD stratum</b>					
PD	2	30993.7	15496.8	40.92	<b>&lt;.001**</b>
CV.PD	2	1635.0	817.5	2.16	0.148
RW.PD	2	807.0	403.5	1.07	0.368
CV.RW.PD	2	1299.2	649.6	1.72	0.211
Residual	16	6059.8	378.7		
<b>Total</b>	<b>35</b>	<b>47947.9</b>			

**Tables of means**

**Grand mean: 157.8**

<b>CV</b>	<b>SST 88</b>	<b>SST 94</b>					
	152.5	163.1					
<b>RW</b>	<b>250</b>	<b>300</b>					
	164.4	151.2					
<b>PD</b>	<b>150</b>	<b>200</b>	<b>250</b>				
	119.4	163.4	190.7				
<b>CV</b>	<b>RW</b>	<b>250</b>	<b>300</b>				
<b>SST 88</b>		159.4	145.7				
<b>SST 94</b>		169.5	156.8				
<b>CV</b>	<b>PD</b>	<b>150</b>	<b>200</b>	<b>250</b>			
<b>SST 88</b>		121.0	160.4	176.2			
<b>SST 94</b>		117.9	166.4	205.1			
<b>RW</b>	<b>PD</b>	<b>150</b>	<b>200</b>	<b>250</b>			
<b>250</b>		124.4	176.4	192.4			
<b>300</b>		114.4	150.4	188.9			
<b>CV</b>	<b>RW</b>	<b>250</b>			<b>300</b>		
<b>SST 88</b>	<b>PD</b>	<b>150</b>	<b>200</b>	<b>250</b>	<b>150</b>	<b>200</b>	<b>250</b>
		119.1	173.3	185.8	123.0	147.4	166.7
<b>SST 94</b>		129.8	179.6	199.1	105.9	153.3	211.1

**CVxRWxPD Caledon 2005  
Seedling Number (Plants m<sup>-2</sup>)**

**A-2**

**Analysis of variance**

Source of variation	d.f.	s.s.	m.s.	v.r.	F pr.
<b>Rep stratum</b>	2	381.4	190.7	0.20	
<b>Rep.Cul stratum</b>					
Cul	2	2503.3	1251.6	1.33	0.361
Residual	4	3765.7	941.4	3.12	
<b>Rep.Cul.RW stratum</b>					
RW	1	740.7	740.7	2.45	0.168
Cul.RW	2	2272.1	1136.1	3.76	0.087
Residual	6	1811.8	302.0	0.67	
<b>Rep.Cul.RW.PD stratum</b>					
PD	2	120029.5	60014.7	132.27	<.001**
Cul.PD	4	1331.0	332.7	0.73	0.578
RW.PD	2	407.3	203.6	0.45	0.644
Cul.RW.PD	4	1637.2	409.3	0.90	0.478
Residual	24	10889.1	453.7		
<b>Total</b>	53	145769.0			

**Tables of means**

**Grand mean: 161.6**

<b>Cul</b>	<b>SST 57</b> 152.0	<b>SST 88</b> 165.7	<b>SST 94</b> 167.1				
<b>RW</b>	<b>250</b> 165.3	<b>300</b> 157.9					
<b>PD</b>	<b>100</b> 102.2	<b>175</b> 165.0	<b>250</b> 217.6				
<b>Cul</b>	<b>RW</b>	<b>250</b> 164.8	<b>300</b> 139.2				
<b>SST 57</b>		163.7	167.7				
<b>SST 88</b>		167.4	166.8				
<b>SST 94</b>							
<b>Cul</b>	<b>PD</b>	<b>100</b> 101.0	<b>175</b> 152.2	<b>250</b> 202.8			
<b>SST 57</b>		97.7	172.2	227.2			
<b>SST 88</b>		108.0	170.7	222.7			
<b>SST 94</b>							
<b>RW</b>	<b>PD</b>	<b>100</b> 106.4	<b>175</b> 165.1	<b>250</b> 224.3			
<b>250</b>		98.0	164.9	210.8			
<b>300</b>							
<b>Cul</b>	<b>RW</b>	<b>250</b> 104.0	<b>175</b> 164.3	<b>250</b> 226.0	<b>300</b> 98.0	<b>175</b> 140.0	<b>250</b> 179.7
<b>SST 57</b>	<b>PD</b>	101.3	167.3	222.3	94.0	177.0	232.0
<b>SST 88</b>		114.0	163.7	224.7	102.0	177.7	220.7
<b>SST 94</b>							

**CVxRWxPD Moorreesburg 2005  
Seedling Number (Plants m<sup>-2</sup>)**

**A-3**

**Analysis of variance**

Source of variation	d.f.(m.v.)	s.s.	m.s.	v.r.	F pr.
<b>Rep stratum</b>	2	1895.5	947.8	2.11	
<b>Rep.Cul stratum</b>					
Cul	1	8.2	8.2	0.02	0.905
Residual	2	898.4	449.2	0.78	
<b>Rep.Cul.RW stratum</b>					
RW	2	1078.7	539.3	0.93	0.432
Cul.RW	2	586.1	293.1	0.51	0.620
Residual	8	4620.5	577.6	1.36	
<b>Rep.Cul.RW.PD stratum</b>					
PD	2	176179.8	88089.9	206.71	<b>&lt;.001**</b>
Cul.PD	2	298.6	149.3	0.35	0.708
RW.PD	4	1239.0	309.8	0.73	0.583
Cul.RW.PD	4	1395.0	348.7	0.82	0.527
Residual	23(1)	9801.3	426.1		
<b>Total</b>	52(1)	195132.5			

**Tables of means**

**Grand mean: 183.9**

<b>Cul</b>	<b>SST 88</b>	<b>SST 94</b>			
	184.3	183.5			
<b>RW</b>	<b>250</b>	<b>300</b>	<b>350</b>		
	187.9	186.2	177.7		
<b>PD</b>	<b>100</b>	<b>175</b>	<b>250</b>		
	111.4	189.2	251.1		
<b>Cul</b>	<b>RW</b>	<b>250</b>	<b>300</b>	<b>350</b>	
<b>SST 88</b>		184.1	190.4	178.3	
<b>SST 94</b>		191.7	181.9	177.0	
<b>Cul</b>	<b>PD</b>	<b>100</b>	<b>175</b>	<b>250</b>	
<b>SST 88</b>		111.4	192.7	248.8	
<b>SST 94</b>		111.4	185.8	253.3	
<b>RW</b>	<b>PD</b>	<b>100</b>	<b>175</b>	<b>250</b>	
<b>250</b>		114.8	189.8	259.0	
<b>300</b>		106.7	197.8	254.0	
<b>350</b>		112.8	180.0	240.2	
<b>Cul</b>	<b>RW</b>	<b>PD</b>	<b>100</b>	<b>175</b>	<b>250</b>
<b>SST 88</b>	<b>250</b>		116.7	191.3	244.3
	<b>300</b>		107.3	208.3	255.7
	<b>350</b>		110.3	178.3	246.3
<b>SST 94</b>	<b>250</b>		113.0	188.3	273.7
	<b>300</b>		106.0	187.3	252.3
	<b>350</b>		115.3	181.7	234.0

Analysis of variance

Source of variation	d.f.	s.s.	m.s.	v.r.	F pr.
Rep stratum	2	1271.8	635.9	1.55	
Rep.CV stratum					
CV	1	1745.2	1745.2	4.26	0.175
Residual	2	820.0	410.0	1.42	
Rep.CV.RW stratum					
RW	2	874.5	437.2	1.51	0.277
CV.RW	2	1008.5	504.3	1.74	0.235
Residual	8	2312.4	289.1	0.85	
Rep.CV.RW.PD stratum					
PD	2	188964.2	94482.1	276.25	<.001**
CV.PD	2	1454.5	727.2	2.13	0.141
RW.PD	4	1005.0	251.3	0.73	0.577
CV.RW.PD	4	1452.1	363.0	1.06	0.397
Residual	24	8208.3	342.0		
<b>Total</b>	<b>53</b>	<b>209116.6</b>			

Tables of means

Grand mean: 178.8

<b>CV</b>	<b>SST 88</b>	<b>SST 94</b>			
	173.1	184.5			
<b>RW</b>	<b>250</b>	<b>300</b>	<b>350</b>		
	184.2	174.6	177.7		
<b>PD</b>	<b>100</b>	<b>175</b>	<b>250</b>		
	105.4	180.7	250.3		
<b>CV</b>	<b>RW</b>	<b>250</b>	<b>300</b>	<b>350</b>	
<b>SST 88</b>		180.9	172.6	165.9	
<b>SST 94</b>		187.6	176.5	189.4	
<b>CV</b>	<b>PD</b>	<b>100</b>	<b>175</b>	<b>250</b>	
<b>SST 88</b>		104.2	167.8	247.4	
<b>SST 94</b>		106.7	193.7	253.1	
<b>RW</b>	<b>PD</b>	<b>100</b>	<b>175</b>	<b>250</b>	
<b>250</b>		107.4	181.6	263.7	
<b>300</b>		104.4	180.0	239.3	
<b>350</b>		104.4	180.6	247.9	
<b>CV</b>	<b>RW</b>	<b>PD</b>	<b>100</b>	<b>175</b>	<b>250</b>
<b>SST 88</b>	<b>250</b>		108.1	165.9	268.7
	<b>300</b>		102.2	171.1	244.4
	<b>350</b>		102.2	166.3	229.2
<b>SST 94</b>	<b>250</b>		106.7	197.3	258.7
	<b>300</b>		106.7	188.9	234.1
	<b>350</b>		106.7	194.9	266.7

**Analysis of variance**

Source of variation	d.f.	s.s.	m.s.	v.r.	F pr.
<b>REP stratum</b>	2	474.53	237.27	1.79	
<b>REP.CV stratum</b>					
CV	1	99.51	99.51	0.75	0.478
Residual	2	265.05	132.53	3.85	
<b>REP.CV.RW stratum</b>					
RW	1	285.64	285.64	8.30	<b>0.045*</b>
CV.RW	1	6.10	6.10	0.18	0.695
Residual	4	137.62	34.41	0.54	
<b>REP.CV.RW.PD stratum</b>					
PD	2	115.64	57.82	0.90	0.425
CV.PD	2	183.24	91.62	1.43	0.268
RW.PD	2	129.91	64.96	1.02	0.385
CV.RW.PD	2	231.98	115.99	1.81	0.195
Residual	16	1023.87	63.99		
Total	35	2953.09			

**Tables of means**

Grand mean 63.4

<b>CV</b>	<b>SST 88</b>	<b>SST 94</b>					
	61.7	65.0					
<b>RW</b>	<b>250</b>	<b>300</b>					
	66.2	60.5					
<b>PD</b>	<b>150</b>	<b>200</b>	<b>250</b>				
	63.7	65.4	61.0				
<b>CV</b>	<b>RW</b>	<b>250</b>	<b>300</b>				
<b>SST 88</b>		64.1	59.3				
<b>SST 94</b>		68.3	61.8				
<b>CV</b>	<b>PD</b>	<b>150</b>	<b>200</b>	<b>250</b>			
<b>SST 88</b>		64.6	64.1	56.4			
<b>SST 94</b>		62.9	66.6	65.6			
<b>RW</b>	<b>PD</b>	<b>150</b>	<b>200</b>	<b>250</b>			
<b>250</b>		66.4	70.6	61.6			
<b>300</b>		61.0	60.1	60.4			
<b>CV</b>	<b>RW</b>	<b>250</b>	<b>200</b>	<b>250</b>	<b>300</b>	<b>200</b>	<b>250</b>
<b>SST 88</b>	<b>PD</b>	<b>150</b>	<b>200</b>	<b>250</b>	<b>150</b>	<b>59.0</b>	<b>53.3</b>
<b>SST 94</b>		63.5	69.3	59.4	65.6	61.3	67.6
		69.2	71.8	63.7	56.5		



**CVxRWxPD Caledon 2005  
Seedling Survival (%)**

A-6

**Analysis of variance**

Source of variation	d.f.	s.s.	m.s.	v.r.	F pr.
<b>REP stratum</b>	2	32.71	16.35	0.10	
<b>REP.CV stratum</b>					
CV	2	496.80	248.40	1.49	0.329
Residual	4	668.79	167.20	2.20	
<b>REP.CV.RW stratum</b>					
RW	1	183.91	183.91	2.42	0.171
CV.RW	2	304.27	152.13	2.00	0.216
Residual	6	456.30	76.05	0.78	
<b>REP.CV.RW.PD stratum</b>					
PD	2	1257.41	628.70	6.45	<b>0.006*</b>
CV.PD	4	270.02	67.50	0.69	0.604
RW.PD	2	102.22	51.11	0.52	0.598
CV.RW.PD	4	253.31	63.33	0.65	0.632
Residual	24	2338.27	97.43		
Total	53	6364.00			

**Grand mean 75.4**

<b>CV</b>	<b>SST 57</b>	<b>SST 88</b>	<b>SST 94</b>				
	71.2	76.5	78.4				
<b>RW</b>	<b>250</b>	<b>300</b>					
	77.2	73.5					
<b>PD</b>	<b>100</b>	<b>175</b>	<b>250</b>				
	81.4	75.1	69.6				
<b>CV</b>	<b>RW</b>	<b>250</b>	<b>300</b>				
<b>SST 57</b>		76.4	66.1				
<b>SST 88</b>		76.2	76.8				
<b>SST 94</b>		79.1	77.7				
<b>CV</b>	<b>PD</b>	<b>100</b>	<b>175</b>	<b>250</b>			
<b>SST 57</b>		79.8	69.0	65.0			
<b>SST 88</b>		78.2	78.7	72.7			
<b>SST 94</b>		86.4	77.6	71.3			
<b>RW</b>	<b>PD</b>	<b>100</b>	<b>175</b>	<b>250</b>			
<b>250</b>		84.8	75.1	71.8			
<b>300</b>		78.1	75.1	67.4			
<b>CV</b>	<b>RW</b>	<b>250</b>	<b>175</b>	<b>250</b>	<b>300</b>		
<b>SST 57</b>	<b>PD</b>	<b>100</b>	<b>175</b>	<b>250</b>	<b>100</b>	<b>175</b>	<b>250</b>
		82.2	74.5	72.4	77.3	63.5	57.5
<b>SST 88</b>		81.1	76.4	71.1	75.3	80.9	74.2
<b>SST 94</b>		91.0	74.3	72.0	81.8	80.8	70.6

**CVxRWxPD Moorreesburg 2005  
Seedling Survival (%)**

**A-7**

**Analysis of variance**

Source of variation	d.f.(mv)	s.s.	m.s.	v.r.	F pr.
<b>Rep stratum</b>	2	234.34	117.17	1.43	
<b>Rep.Cul stratum</b>					
Cul	1	3.63	3.63	0.04	0.853
Residual	2	163.62	81.81	1.09	
<b>Rep.Cul.RW stratum</b>					
RW	2	166.75	83.38	1.11	0.374
Cul.RW	2	89.38	44.69	0.60	0.573
Residual	8	598.94	74.87	1.26	
<b>Rep.Cul.RW.PD stratum</b>					
PD	2	780.39	390.20	6.57	<b>0.006*</b>
Cul.PD	2	54.38	27.19	0.46	0.638
RW.PD	4	317.76	79.44	1.34	0.286
Cul.RW.PD	4	216.26	54.07	0.91	0.474
Residual	23(1)	1365.78	59.38		
<b>Total</b>	52(1)	3910.83			

**Tables of means**

Grand mean 85.3

<b>CV</b>	<b>SST 88</b> 85.6	<b>SST 94</b> 84.9			
<b>RW</b>	<b>250</b> 87.1	<b>300</b> 85.6	<b>350</b> 83.2		
<b>PD</b>	<b>100</b> 89.2	<b>175</b> 86.2	<b>250</b> 80.4		
<b>CV</b>	<b>RW</b>	<b>250</b>	<b>300</b>	<b>350</b>	
<b>SST 88</b>		86.2	87.6	82.9	
<b>SST 94</b>		87.9	83.6	83.4	
<b>CV</b>	<b>PD</b>	<b>100</b>	<b>175</b>	<b>250</b>	
<b>SST 88</b>		89.2	88.0	79.6	
<b>SST 94</b>		89.2	84.5	81.2	
<b>RW</b>	<b>PD</b>	<b>100</b>	<b>175</b>	<b>250</b>	
<b>250</b>		91.7	86.5	82.9	
<b>300</b>		85.3	90.2	81.3	
<b>350</b>		90.4	82.0	77.0	
<b>CV</b>	<b>RW</b>	<b>PD</b>	<b>100</b>	<b>175</b>	<b>250</b>
<b>SST 88</b>	<b>250</b>		93.2	87.4	78.2
	<b>300</b>		85.9	95.2	81.8
	<b>350</b>		88.4	81.6	78.8
<b>SST 94</b>	<b>250</b>		90.3	85.7	87.6
	<b>300</b>		84.7	85.2	80.8
	<b>350</b>		92.4	82.5	75.2

**CVxRWxPD Hopefield 2005  
Seedling Survival (%)**

**A-8**

**Analysis of variance**

Source of variation	d.f.	s.s.	m.s.	v.r.	F pr.
<b>REP stratum</b>	2	302.33	151.17	6.48	
<b>REP.CV stratum</b>					
CV	1	253.64	253.64	10.88	0.081
Residual	2	46.64	23.32	0.39	
<b>REP.CV.RW stratum</b>					
RW	2	146.02	73.01	1.22	0.344
CV.RW	2	187.28	93.64	1.57	0.266
Residual	8	476.88	59.61	0.76	
<b>REP.CV.RW.PD stratum</b>					
PD	2	240.91	120.46	1.54	0.234
CV.PD	2	298.12	149.06	1.91	0.170
RW.PD	4	168.54	42.14	0.54	0.708
CV.RW.PD	4	194.22	48.56	0.62	0.652
Residual	24	1874.89	78.12		
Total	53	4189.48			

**Tables of means**

**Grand mean 82.2**

<b>CV</b>	<b>SST 88</b>	<b>SST 94</b>			
	80.0	84.3			
<b>RW</b>	<b>250</b>	<b>300</b>	<b>350</b>		
	84.4	80.4	81.7		
<b>PD</b>	<b>100</b>	<b>175</b>	<b>250</b>		
	84.5	82.6	79.4		
<b>CV</b>	<b>RW</b>	<b>250</b>	<b>300</b>	<b>350</b>	
<b>SST 88</b>		82.8	80.2	77.1	
<b>SST 94</b>		85.9	80.6	86.4	
<b>CV</b>	<b>PD</b>	<b>100</b>	<b>175</b>	<b>250</b>	
<b>SST 88</b>		83.7	77.1	79.2	
<b>SST 94</b>		85.3	88.1	79.6	
<b>RW</b>	<b>PD</b>	<b>100</b>	<b>175</b>	<b>250</b>	
<b>250</b>		85.9	82.8	84.4	
<b>300</b>		84.1	82.7	74.4	
<b>350</b>		83.6	82.3	79.3	
<b>CV</b>	<b>RW</b>	<b>PD</b>	<b>100</b>	<b>175</b>	<b>250</b>
<b>SST 88</b>	<b>250</b>		86.5	75.8	86.0
	<b>300</b>		82.8	79.4	78.2
	<b>350</b>		81.8	76.0	73.3
<b>SST 94</b>	<b>250</b>		85.3	89.7	82.8
	<b>300</b>		85.3	85.9	70.7
	<b>350</b>		85.3	88.6	85.3

**CVxRWxPD Riversdale 2006  
Seedling Number (Plants m<sup>-2</sup>)**

**A-9**

**Analysis of variance**

Source of variation	d.f.	s.s.	m.s.	v.r.	F pr.
<b>Rep stratum</b>	2	7795.8	3897.9	15.36	
<b>Rep.CV stratum</b>					
CV	2	1013.2	506.6	2.00	0.250
Residual	4	1014.8	253.7	0.87	
<b>Rep.CV.RW stratum</b>					
RW	1	2388.2	2388.2	8.22	<b>0.029*</b>
CV.RW	2	446.1	223.0	0.77	0.505
Residual	6	1742.9	290.5	1.02	
<b>Rep.CV.RW.PD stratum</b>					
PD	2	65622.9	32811.5	114.90	<b>&lt;.001**</b>
CV.PD	4	1545.2	386.3	1.35	0.280
RW.PD	2	39.2	19.6	0.07	0.934
CV.RW.PD	4	2026.7	506.7	1.77	0.167
Residual	24	6853.8	285.6		
Total	53	90488.7			

**Tables of means**

**Grand mean: 157.6**

<b>CV</b>	<b>SST015</b>	<b>SST57</b>	<b>SST88</b>				
	153.8	163.7	155.4				
<b>RW</b>	<b>250</b>	<b>300</b>					
	164.2	150.9					
<b>PD</b>	<b>100</b>	<b>150</b>	<b>200</b>				
	112.8	162.1	197.9				
<b>CV</b>	<b>RW</b>	<b>250</b>	<b>300</b>				
<b>SST015</b>		159.4	148.1				
<b>SST57</b>		174.2	153.1				
<b>SST88</b>		159.1	151.6				
<b>CV</b>	<b>PD</b>	<b>100</b>	<b>150</b>	<b>200</b>			
<b>SST015</b>		112.8	151.0	197.6			
<b>SST57</b>		113.6	168.4	209.0			
<b>SST88</b>		112.1	166.9	187.1			
<b>RW</b>	<b>PD</b>	<b>100</b>	<b>150</b>	<b>200</b>			
<b>250</b>		118.5	168.6	205.6			
<b>300</b>		107.2	155.6	190.1			
<b>CV</b>	<b>RW</b>	<b>250</b>	<b>150</b>	<b>200</b>	<b>300</b>	<b>150</b>	<b>200</b>
<b>SST015</b>	<b>PD</b>	109.3	153.8	215.1	116.3	148.1	180.0
<b>SST57</b>		123.6	180.4	218.7	103.7	156.3	199.3
<b>SST88</b>		122.7	171.6	183.1	101.5	162.2	191.1

**Analysis of variance**

Source of variation	d.f.	s.s.	m.s.	v.r.	F pr.
<b>REP stratum</b>	2	6023.8	3011.9	3.85	
<b>REP.CV stratum</b>					
CV	2	3159.0	1579.5	2.02	0.247
Residual	4	3126.2	781.5	1.26	
<b>REP.CV.RW stratum</b>					
RW	1	1986.9	1986.9	3.20	0.124
CV.RW	2	3150.7	1575.3	2.54	0.159
Residual	6	3727.1	621.2	0.85	
<b>REP.CV.RW.PD stratum</b>					
PD	2	86377.5	43188.7	59.22	<.001**
CV.PD	4	1493.7	373.4	0.51	0.727
RW.PD	2	1159.6	579.8	0.80	0.463
CV.RW.PD	4	348.5	87.1	0.12	0.974
Residual	24	17502.3	729.3		
<b>Total</b>	53	128055.3			

**Tables of means**

Grand mean: 209.4

<b>CV</b>	<b>SST015</b>	<b>SST57</b>	<b>SST88</b>				
	201.8	219.9	206.6				
<b>RW</b>	<b>250</b>	<b>300</b>					
	215.5	203.4					
<b>PD</b>	<b>150</b>	<b>200</b>	<b>250</b>				
	160.0	210.5	257.9				
<b>CV</b>	<b>RW</b>	<b>250</b>	<b>300</b>				
<b>SST015</b>		217.5	186.2				
<b>SST57</b>		225.5	214.3				
<b>SST88</b>		203.6	209.6				
<b>CV</b>	<b>PD</b>	<b>150</b>	<b>200</b>	<b>250</b>			
<b>SST015</b>		158.1	206.5	240.9			
<b>SST57</b>		163.6	221.6	274.5			
<b>SST88</b>		158.1	203.3	258.3			
<b>RW</b>	<b>PD</b>	<b>150</b>	<b>200</b>	<b>250</b>			
<b>250</b>		168.3	210.1	268.1			
<b>300</b>		151.6	210.9	247.7			
<b>CV</b>	<b>RW</b>	<b>250</b>	<b>200</b>	<b>250</b>	<b>300</b>	<b>200</b>	<b>250</b>
<b>SST015</b>	<b>PD</b>	172.4	216.0	264.0	143.7	197.0	217.8
<b>SST57</b>		172.4	218.7	285.3	154.8	224.4	263.7
<b>SST88</b>		160.0	195.6	255.1	156.3	211.1	261.5

**CVxRWxPD Caledon 2006  
Seedling Number (Plants m<sup>-2</sup>)**

A-11

**Analysis of variance**

Source of variation	d.f.	s.s.	m.s.	v.r.	F pr.
<b>REP stratum</b>	2	679.7	339.9	0.65	
<b>REP.CV stratum</b>					
CV	2	3831.7	1915.9	3.69	0.124
Residual	4	2078.7	519.7	5.97	
<b>REP.CV.RW stratum</b>					
RW	1	5670.0	5670.0	65.13	<.001**
CV.RW	2	303.8	151.9	1.75	0.253
Residual	6	522.3	87.1	0.35	
<b>REP.CV.RW.PD stratum</b>					
PD	2	212253.0	106126.5	423.99	<.001**
CV.PD	4	1597.7	399.4	1.60	0.208
RW.PD	2	5688.4	2844.2	11.36	<.001**
CV.RW.PD	4	300.5	75.1	0.30	0.875
Residual	24	6007.4	250.3		
Total	53	238933.1			

**Tables of means**

**Grand mean: 189.8**

<b>CV</b>	<b>SST015</b>	<b>SST57</b>	<b>SST88</b>				
	178.3	192.6	198.4				
<b>RW</b>	<b>250</b>	<b>300</b>					
	200.0	179.5					
<b>PD</b>	<b>100</b>	<b>175</b>	<b>250</b>				
	111.2	193.5	264.6				
<b>CV</b>	<b>RW</b>	<b>250</b>	<b>300</b>				
<b>SST015</b>		188.7	167.9				
<b>SST57</b>		205.6	179.5				
<b>SST88</b>		205.6	191.1				
<b>CV</b>	<b>SD</b>	<b>100</b>	<b>175</b>	<b>250</b>			
<b>SST015</b>		107.3	183.1	244.6			
<b>SST57</b>		105.7	196.6	275.4			
<b>SST88</b>		120.5	200.8	273.8			
<b>RW</b>	<b>SD</b>	<b>100</b>	<b>175</b>	<b>250</b>			
<b>250</b>		116.1	194.7	289.2			
<b>300</b>		106.2	192.3	240.0			
<b>CV</b>	<b>RW</b>	<b>250</b>	<b>175</b>	<b>250</b>	<b>300</b>	<b>175</b>	<b>250</b>
<b>SST015</b>	<b>SD</b>	<b>100</b>	<b>175</b>	<b>250</b>	<b>100</b>	<b>175</b>	<b>250</b>
		109.3	184.0	272.9	105.2	182.2	216.3
<b>SST57</b>		117.3	199.1	300.4	94.1	194.1	250.4
<b>SST88</b>		121.8	200.9	294.2	119.3	200.7	253.3

Analysis of variance Source of variation	d.f.	s.s.	m.s.	v.r.	F pr.
REP stratum	2	230.93	115.46	2.88	
REP.CV stratum					
CV	1	3.32	3.32	0.08	0.800
Residual	2	80.16	40.08	0.29	
REP.CV.RW stratum					
RW	2	1799.49	899.74	6.40	<b>0.022*</b>
CV.RW	2	179.82	89.91	0.64	0.553
Residual	8	1124.86	140.61	2.23	
REP.CV.RW.PD stratum					
PD	2	232671.24	116335.62	1841.14	<b>&lt;.001**</b>
CV.PD	2	22.01	11.00	0.17	0.841
RW.PD	4	1644.13	411.03	6.51	<b>0.001*</b>
CV.RW.PD	4	177.30	44.33	0.70	0.599
Residual	24	1516.48	63.19		
<b>Total</b>	<b>53</b>	<b>239449.73</b>			

Tables of means

Grand mean: 199.0

<b>CV</b>	<b>SST015</b>	<b>SST88</b>			
	198.7	199.2			
<b>RW</b>	<b>250</b>	<b>300</b>	<b>350</b>		
	206.8	196.9	193.1		
<b>PD</b>	<b>100</b>	<b>175</b>	<b>250</b>		
	118.6	198.9	279.4		
<b>CV</b>	<b>RW</b>	<b>250</b>	<b>300</b>	<b>350</b>	
<b>SST015</b>		208.6	197.0	190.5	
<b>SST88</b>		205.0	196.8	195.8	
<b>CV</b>	<b>PD</b>	<b>100</b>	<b>175</b>	<b>250</b>	
<b>SST015</b>		119.2	198.5	278.4	
<b>SST88</b>		118.0	199.2	280.4	
<b>RW</b>	<b>PD</b>	<b>100</b>	<b>175</b>	<b>250</b>	
<b>250</b>		117.8	205.3	297.3	
<b>300</b>		119.6	198.5	272.6	
<b>350</b>		118.4	192.7	268.3	
<b>CV</b>	<b>RW</b>	<b>PD</b>	<b>100</b>	<b>175</b>	<b>250</b>
<b>SST015</b>	<b>250</b>		118.2	206.2	301.3
	<b>300</b>		120.0	200.0	271.1
	<b>350</b>		119.4	189.2	262.9
<b>SST88</b>	<b>250</b>		117.3	204.4	293.3
	<b>300</b>		119.3	197.0	274.1
	<b>350</b>		117.5	196.2	273.7

**CVxRWxPD Hopefield 2006  
Seedling Number (Plants m<sup>-2</sup>)**

A-13

**Analysis of variance**

Source of variation	d.f.	s.s.	m.s.	v.r.	F pr.
<b>REP stratum</b>	2	692.4	346.2	0.80	
<b>REP.CV stratum</b>					
CV	1	10180.8	10180.8	23.65	<b>0.040*</b>
Residual	2	861.1	430.6	0.67	
<b>REP.CV.RW stratum</b>					
RW	2	1299.5	649.7	1.01	0.406
CV.RW	2	1281.4	640.7	1.00	0.411
Residual	8	5142.6	642.8	1.02	
<b>REP.CV.RW.PD stratum</b>					
PD	2	191989.7	95994.8	152.79	<b>&lt;.001**</b>
CV.PD	2	7232.2	3616.1	5.76	<b>0.009*</b>
RW.PD	4	195.5	48.9	0.08	0.988
CV.RW.PD	4	541.6	135.4	0.22	0.927
Residual	24	15078.7	628.3		
<b>Total</b>	53	234495.5			

**Tables of means**

Grand mean: 188.3

<b>CV</b>	<b>SST015</b>	<b>SST88</b>			
	174.6	202.0			
<b>RW</b>	<b>250</b>	<b>300</b>	<b>350</b>		
	195.1	183.7	186.1		
<b>PD</b>	<b>100</b>	<b>175</b>	<b>250</b>		
	113.4	192.3	259.3		
<b>CV</b>	<b>RW</b>	<b>250</b>	<b>300</b>	<b>350</b>	
<b>SST015</b>		187.9	164.7	171.2	
<b>SST88</b>		202.4	202.7	201.1	
<b>CV</b>	<b>PD</b>	<b>100</b>	<b>175</b>	<b>250</b>	
<b>SST015</b>		109.0	185.5	229.2	
<b>SST88</b>		117.8	199.0	289.3	
<b>RW</b>	<b>PD</b>	<b>100</b>	<b>175</b>	<b>250</b>	
<b>250</b>		119.1	199.1	267.1	
<b>300</b>		107.4	190.7	253.0	
<b>350</b>		113.7	187.0	257.8	
<b>CV</b>	<b>RW</b>	<b>PD</b>	<b>100</b>	<b>175</b>	<b>250</b>
<b>SST015</b>	<b>250</b>		120.9	198.2	244.4
	<b>300</b>		95.6	184.4	214.1
	<b>350</b>		110.5	174.0	229.2
<b>SST88</b>	<b>250</b>		117.3	200.0	289.8
	<b>300</b>		119.3	197.0	291.9
	<b>350</b>		116.8	200.0	286.3



**Analysis of variance**

Source of variation	d.f.	s.s.	m.s.	v.r.	F pr.
<b>REP stratum</b>	2	1865.26	932.63	12.26	
<b>REP.CV stratum</b>					
CV	2	217.95	108.98	1.43	0.340
Residual	4	304.35	76.09	0.99	
<b>REP.CV.RW stratum</b>					
RW	1	737.47	737.47	9.62	<b>0.021*</b>
CV.RW	2	164.70	82.35	1.07	0.399
Residual	6	459.91	76.65	1.23	
<b>REP.CV.RW.PD stratum</b>					
PD	2	1093.46	546.73	8.79	<b>0.001*</b>
CV.PD	4	352.57	88.14	1.42	0.258
RW.PD	2	18.86	9.43	0.15	0.860
CV.RW.PD	4	625.27	156.32	2.51	0.068
Residual	24	1492.31	62.18		
Total	53	7332.13			

**Tables of means**

Grand mean 85.1

<b>CV</b>	<b>SST015</b>	<b>SST57</b>	<b>SST88</b>				
	83.3	87.9	84.1				
<b>RW</b>	<b>250</b>	<b>300</b>					
	88.8	81.4					
<b>PD</b>	<b>100</b>	<b>150</b>	<b>200</b>				
	89.8	86.4	79.0				
<b>CV</b>	<b>RW</b>	<b>250</b>	<b>300</b>				
<b>SST015</b>		85.2	81.3				
<b>SST57</b>		94.0	81.8				
<b>SST88</b>		87.2	81.0				
<b>CV</b>	<b>PD</b>	<b>100</b>	<b>150</b>	<b>200</b>			
<b>SST015</b>		90.3	80.5	79.0			
<b>SST57</b>		90.0	90.1	83.6			
<b>SST88</b>		89.2	88.6	74.5			
<b>RW</b>	<b>PD</b>	<b>100</b>	<b>150</b>	<b>200</b>			
<b>250</b>		94.3	89.9	82.1			
<b>300</b>		85.3	82.9	75.9			
<b>CV</b>	<b>RW</b>	<b>250</b>	<b>150</b>	<b>200</b>	<b>300</b>	<b>150</b>	<b>200</b>
<b>SST015</b>	<b>PD</b>	<b>100</b>	<b>150</b>	<b>200</b>	<b>100</b>	<b>79.0</b>	<b>72.0</b>
		87.5	82.0	86.0	93.0		
<b>SST57</b>		97.8	96.6	87.5	82.1	<b>83.7</b>	<b>79.7</b>
<b>SST88</b>		97.7	91.1	72.9	80.8	<b>86.1</b>	<b>76.1</b>

**Analysis of variance**

Source of variation	d.f.	s.s.	m.s.	v.r.	F pr.
<b>REP stratum</b>	2	870.7	435.3	3.12	
<b>REP.CV stratum</b>					
CV	2	433.0	216.5	1.55	0.317
Residual	4	558.8	139.7	1.55	
<b>REP.CV.RW stratum</b>					
RW	1	343.6	343.6	3.81	0.099
CV.RW	2	485.7	242.8	2.69	0.146
Residual	6	541.4	90.2	0.88	
<b>REP.CV.RW.PD stratum</b>					
PD	2	69.3	34.6	0.34	0.716
CV.PD	4	120.9	30.2	0.30	0.877
RW.PD	2	207.2	103.6	1.02	0.377
CV.RW.PD	4	14.2	3.5	0.03	0.998
Residual	24	2449.2	102.0		
Total	53	6093.9			

**Tables of means**

Grand mean 84.0

<b>CV</b>	<b>SST015</b>	<b>SST57</b>	<b>SST88</b>				
	81.3	88.0	82.9				
<b>RW</b>	<b>250</b>	<b>300</b>					
	86.6	81.5					
<b>PD</b>	<b>150</b>	<b>200</b>	<b>250</b>				
	85.3	84.3	82.5				
<b>CV</b>	<b>RW</b>	<b>250</b>	<b>300</b>				
<b>SST015</b>		87.6	75.0				
<b>SST57</b>		90.3	85.6				
<b>SST88</b>		81.8	83.9				
<b>CV</b>	<b>PD</b>	<b>150</b>	<b>200</b>	<b>250</b>			
<b>SST015</b>		84.3	82.6	77.1			
<b>SST57</b>		87.6	88.6	87.7			
<b>SST88</b>		84.0	81.7	82.9			
<b>RW</b>	<b>PD</b>	<b>150</b>	<b>200</b>	<b>250</b>			
<b>250</b>		89.7	84.2	85.8			
<b>300</b>		80.8	84.5	79.3			
<b>CV</b>	<b>RW</b>	<b>250</b>	<b>200</b>	<b>250</b>	<b>300</b>	<b>200</b>	<b>250</b>
<b>SST015</b>	<b>PD</b>	<b>150</b>	<b>200</b>	<b>250</b>	<b>150</b>	<b>78.8</b>	<b>69.7</b>
		92.0	86.4	84.5	76.6		
<b>SST57</b>		92.3	87.5	91.1	82.9	<b>89.8</b>	<b>84.2</b>
<b>SST88</b>		84.9	78.6	81.9	83.0	<b>84.8</b>	<b>83.9</b>

Analysis of variance

Source of variation	d.f.	s.s.	m.s.	v.r.	F pr.
<b>REP stratum</b>	2	133.88	66.94	0.89	
<b>REP.CV stratum</b>					
CV	2	778.40	389.20	5.15	0.078
Residual	4	302.25	75.56	3.22	
<b>REP.CV.RW stratum</b>					
RW	1	916.24	916.24	39.09	<.001**
CV.RW	2	120.32	60.16	2.57	0.157
Residual	6	140.63	23.44	0.50	
<b>REP.CV.RW.PD stratum</b>					
PD	2	174.76	87.38	1.87	0.175
CV.PD	4	329.21	82.30	1.76	0.169
RW.PD	2	485.47	242.73	5.20	0.013*
CV.RW.PD	4	151.79	37.95	0.81	0.529
Residual	24	1119.45	46.64		
Total	53	4652.41			

Tables of means

Grand mean 87.23

<b>CV</b>	<b>SST015</b>	<b>SST57</b>	<b>SST88</b>				
	82.59	87.21	91.89				
<b>RW</b>	<b>250</b>	<b>300</b>					
	91.35	83.11					
<b>PD</b>	<b>100</b>	<b>175</b>	<b>250</b>				
	88.49	88.53	84.69				
<b>CV</b>	<b>RW</b>	<b>250</b>	<b>300</b>				
<b>SST015</b>		86.30	78.89				
<b>SST57</b>		93.33	81.09				
<b>SST88</b>		94.43	89.36				
<b>CV</b>	<b>PD</b>	<b>100</b>	<b>175</b>	<b>250</b>			
<b>SST015</b>		85.81	83.71	78.27			
<b>SST57</b>		83.68	90.01	87.95			
<b>SST88</b>		95.97	91.86	87.85			
<b>RW</b>	<b>PD</b>	<b>100</b>	<b>175</b>	<b>250</b>			
<b>250</b>		92.44	89.06	92.56			
<b>300</b>		84.53	87.99	76.82			
<b>CV</b>	<b>RW</b>	<b>250</b>	<b>175</b>	<b>250</b>	<b>300</b>	<b>175</b>	<b>250</b>
<b>SST015</b>	<b>PD</b>	<b>100</b>	<b>175</b>	<b>250</b>	<b>100</b>	<b>175</b>	<b>250</b>
		87.47	84.11	87.32	84.15	83.30	69.21
<b>SST57</b>		92.89	91.16	95.94	74.48	88.85	79.95
<b>SST88</b>		96.97	91.90	94.41	94.97	91.83	81.29

**Analysis of variance**

Source of variation	d.f.	s.s.	m.s.	v.r.	F pr.
<b>REP stratum</b>	2	28.71	14.35	2.19	
<b>REP.CV stratum</b>					
CV	1	0.02	0.02	0.00	0.962
Residual	2	13.10	6.55	0.24	
<b>REP.CV.RW stratum</b>					
RW	2	219.57	109.78	4.00	0.062
CV.RW	2	21.88	10.94	0.40	0.684
Residual	8	219.52	27.44	2.21	
<b>REP.CV.RW.PD stratum</b>					
PD	2	253.67	126.83	10.20	<.001**
CV.PD	2	12.64	6.32	0.51	0.608
RW.PD	4	190.53	47.63	3.83	0.015*
CV.RW.PD	4	24.59	6.15	0.49	0.740
Residual	24	298.35	12.43		
Total	53	1282.58			

**Tables of means**

**Grand mean 91.71**

<b>CV</b>	<b>SST015</b>	<b>SST88</b>			
	91.73	91.69			
<b>RW</b>	<b>250</b>	<b>300</b>	<b>350</b>		
	94.39	91.21	89.53		
<b>PD</b>	<b>100</b>	<b>175</b>	<b>250</b>		
	94.67	90.93	89.53		
<b>CV</b>	<b>RW</b>	<b>250</b>	<b>300</b>	<b>350</b>	
<b>SST015</b>		95.09	91.39	88.70	
<b>SST88</b>		93.69	91.02	90.36	
<b>CV</b>	<b>PD</b>	<b>100</b>	<b>175</b>	<b>250</b>	
<b>SST015</b>		95.36	90.73	89.10	
<b>SST88</b>		93.98	91.13	89.96	
<b>RW</b>	<b>PD</b>	<b>100</b>	<b>175</b>	<b>250</b>	
<b>250</b>		94.00	93.90	95.28	
<b>300</b>		95.48	90.78	87.35	
<b>350</b>		94.51	88.12	85.96	
<b>CV</b>	<b>RW</b>	<b>PD</b>	<b>100</b>	<b>175</b>	<b>250</b>
<b>SST015</b>	<b>250</b>		94.58	94.27	96.43
	<b>300</b>		96.00	91.43	86.76
	<b>350</b>		95.49	86.49	84.11
<b>SST88</b>	<b>250</b>		93.43	93.52	94.13
	<b>300</b>		94.97	90.13	87.95
	<b>350</b>		93.53	89.75	87.81

**Analysis of variance**

Source of variation	d.f.	s.s.	m.s.	v.r.	F pr.
<b>REP stratum</b>	<b>2</b>	<b>23.66</b>	<b>11.83</b>	<b>0.35</b>	
<b>REP.CV stratum</b>					
CV	1	1568.12	1568.12	46.90	<b>0.021*</b>
Residual	2	66.86	33.43	0.28	
<b>REP.CV.RW stratum</b>					
RW	2	335.75	167.88	1.42	0.297
CV.RW	2	350.56	175.28	1.48	0.284
Residual	8	948.02	118.50	1.34	
<b>REP.CV.RW.PD stratum</b>					
PD	2	507.32	253.66	2.86	0.077
CV.PD	2	512.30	256.15	2.89	0.075
RW.PD	4	88.07	22.02	0.25	0.908
CV.RW.PD	4	190.16	47.54	0.54	0.710
Residual	24	2126.99	88.62		
Total	53	6717.81			

**Tables of means**

Grand mean 87.2

<b>CV</b>	<b>SST015</b>	<b>SST88</b>			
	81.8	92.6			
<b>RW</b>	<b>250</b>	<b>300</b>	<b>350</b>		
	90.6	84.7	86.3		
<b>PD</b>	<b>100</b>	<b>175</b>	<b>250</b>		
	90.5	87.9	83.1		
<b>CV</b>	<b>RW</b>	<b>250</b>	<b>300</b>	<b>350</b>	
<b>SST015</b>		88.5	76.4	80.4	
<b>SST88</b>		92.6	92.9	92.1	
<b>CV</b>	<b>PD</b>	<b>100</b>	<b>175</b>	<b>250</b>	
<b>SST015</b>		87.2	84.8	73.4	
<b>SST88</b>		93.8	91.0	92.8	
<b>RW</b>	<b>PD</b>	<b>100</b>	<b>175</b>	<b>250</b>	
<b>250</b>		95.1	91.1	85.6	
<b>300</b>		85.7	87.2	81.1	
<b>350</b>		90.7	85.5	82.6	
<b>CV</b>	<b>RW</b>	<b>PD</b>	<b>100</b>	<b>175</b>	<b>250</b>
<b>SST015</b>	<b>250</b>		96.7	90.6	78.2
	<b>300</b>		76.4	84.3	68.5
	<b>350</b>		88.4	79.5	73.3
<b>SST88</b>	<b>250</b>		93.4	91.5	93.0
	<b>300</b>		95.0	90.1	93.7
	<b>350</b>		93.0	91.5	91.9

**CVxRWxPD Swellendam 2005**  
**Heads m<sup>-2</sup>**

**B-1**

**Analysis of variance**

Source of variation	d.f.	s.s.	m.s.	v.r.	F pr.
<b>Rep stratum</b>	2	5646.6	2823.3	1.37	
<b>Rep.CV stratum</b>					
CV	1	7744.0	7744.0	3.76	0.192
Residual	2	4114.7	2057.3	36.67	
<b>Rep.CV.RW stratum</b>					
RW	1	6423.7	6423.7	114.49	<.001**
CV.RW	1	202.3	202.3	3.60	0.130
Residual	4	224.4	56.1	0.12	
<b>Rep.CV.RW.PD stratum</b>					
PD	2	8212.6	4106.3	9.11	0.002*
CV.PD	2	888.6	444.3	0.99	0.395
RW.PD	2	773.6	386.8	0.86	0.443
CV.RW.PD	2	1125.7	562.8	1.25	0.314
Residual	16	7215.3	451.0		
<b>Total</b>	35	42571.4			

**Tables of means**

**Grand mean: 141.8**

<b>CV</b>	<b>SST 88</b>	<b>SST 94</b>					
	127.1	156.4					
<b>RW</b>	<b>250</b>	<b>300</b>					
	155.1	128.4					
<b>PD</b>	<b>150</b>	<b>200</b>	<b>250</b>				
	142.7	159.8	122.8				
<b>CV</b>	<b>RW</b>	<b>250</b>	<b>300</b>				
<b>SST 88</b>		142.8	111.4				
<b>SST 94</b>		167.4	145.4				
<b>CV</b>	<b>PD</b>	<b>150</b>	<b>200</b>	<b>250</b>			
SST 88		121.2	147.0	113.0			
SST 94		164.1	172.5	132.6			
<b>RW</b>	<b>PD</b>	<b>150</b>	<b>200</b>	<b>250</b>			
<b>250</b>		152.0	170.7	142.7			
<b>300</b>		133.3	148.9	103.0			
<b>CV</b>	<b>RW</b>	<b>250</b>			<b>300</b>		
<b>PD</b>		<b>150</b>	<b>200</b>	<b>250</b>	<b>150</b>	<b>200</b>	<b>250</b>
SST 88		129.8	155.6	143.1	112.6	138.5	83.0
SST 94		174.2	185.8	142.2	154.1	159.3	123.0

**CVxRWxPD Caledon 2005**  
Heads m<sup>-2</sup>

**B-2**

**Analysis of variance**

Source of variation	d.f.	s.s.	m.s.	v.r.	F pr.
<b>Rep stratum</b>	2	1787.3	893.7	0.31	
<b>Rep.Cul stratum</b>					
Cul	2	8248.2	4124.1	1.43	0.339
Residual	4	11513.2	2878.3	1.21	
<b>Rep.Cul.RW stratum</b>					
RW	1	13484.8	13484.8	5.66	0.055
Cul.RW	2	1021.2	510.6	0.21	0.813
Residual	6	14296.1	2382.7	2.99	
<b>Rep.Cul.RW.PD stratum</b>					
PD	2	5656.5	2828.3	3.55	<b>0.045*</b>
Cul.PD	4	5199.8	1300.0	1.63	0.199
RW.PD	2	626.1	313.0	0.39	0.680
Cul.RW.PD	4	357.7	89.4	0.11	0.977
Residual	24	19137.4	797.4		
<b>Total</b>	<b>53</b>	<b>81328.2</b>			

**Tables of means**

**Grand mean: 238.5**

<b>Cul</b>	<b>SST 57</b>	<b>SST 88</b>	<b>SST 94</b>				
	221.1	248.8	245.6				
<b>RW</b>	<b>250</b>	<b>300</b>					
	254.3	222.7					
<b>PD</b>	<b>100</b>	<b>175</b>	<b>250</b>				
	232.1	230.5	253.0				
<b>Cul</b>	<b>RW</b>	<b>250</b>	<b>300</b>				
<b>SST 57</b>		234.4	207.9				
<b>SST 88</b>		261.0	236.5				
<b>SST 94</b>		267.6	223.7				
<b>Cul</b>	<b>PD</b>	<b>100</b>	<b>175</b>	<b>250</b>			
<b>SST 57</b>		221.9	223.0	218.5			
<b>SST 88</b>		246.3	235.1	265.0			
<b>SST 94</b>		228.1	233.3	275.4			
<b>RW</b>	<b>PD</b>	<b>100</b>	<b>175</b>	<b>250</b>			
<b>250</b>		250.4	241.5	271.1			
<b>300</b>		213.8	219.5	234.8			
<b>Cul</b>	<b>RW</b>	<b>250</b>	<b>300</b>	<b>100</b>	<b>175</b>	<b>250</b>	
<b>SST 57</b>	<b>PD</b>	<b>100</b>	<b>100</b>	<b>231.1</b>	<b>208.1</b>	<b>209.6</b>	<b>205.9</b>
<b>SST 88</b>		235.6	236.4	239.1	230.4	231.1	248.1
<b>SST 94</b>		262.2	239.1	281.8	230.4	231.1	248.1
		253.3	248.9	300.4	203.0	217.8	250.4

**CVxRWxPD Riversdale 2006**  
Heads m<sup>-2</sup>

**B-3**

**Analysis of variance**

Source of variation	d.f.	s.s.	m.s.	v.r.	F pr.
<b>Rep stratum</b>		2	157.1	78.5	0.08
<b>Rep.CV stratum</b>					
CV	2	1811.4	905.7	0.96	0.457
Residual	4	3774.6	943.6	1.41	
<b>Rep.CV.RW stratum</b>					
RW	1	14881.7	14881.7	22.20	<b>0.003*</b>
CV.RW	2	606.5	303.2	0.45	0.656
Residual	6	4021.2	670.2	1.09	
<b>Rep.CV.RW.PD stratum</b>					
PD	2	163.0	81.5	0.13	0.876
CV.PD	4	1416.8	354.2	0.58	0.682
RW.PD	2	94.5	47.3	0.08	0.926
CV.RW.PD	4	338.3	84.6	0.14	0.967
Residual	24	14724.7	613.5		
<b>Total</b>	<b>53</b>	<b>41989.7</b>			

**Tables of means**

**Grand mean: 303.1**

<b>CV</b>	<b>SST015</b>	<b>SST57</b>	<b>SST88</b>				
	295.4	309.3	304.7				
<b>RW</b>	<b>250</b>	<b>300</b>					
	319.7	286.5					
<b>PD</b>	<b>100</b>	<b>150</b>	<b>200</b>				
	300.7	303.9	304.7				
<b>CV</b>	<b>RW</b>	<b>250</b>	<b>300</b>				
<b>SST015</b>		307.3	283.5				
<b>SST57</b>		327.7	290.9				
<b>SST88</b>		324.1	285.2				
<b>CV</b>	<b>PD</b>	<b>100</b>	<b>150</b>	<b>200</b>			
<b>SST015</b>		288.8	295.0	302.2			
<b>SST57</b>		304.6	318.1	305.2			
<b>SST88</b>		308.7	298.6	306.7			
<b>RW</b>	<b>PD</b>	<b>100</b>	<b>150</b>	<b>200</b>			
250		316.4	322.4	320.3			
300		284.9	285.4	289.1			
<b>CV</b>	<b>RW</b>	<b>250</b>	<b>150</b>	<b>200</b>	<b>300</b>	<b>150</b>	<b>200</b>
<b>SST015</b>	<b>PD</b>	<b>100</b>	<b>150</b>	<b>200</b>	<b>100</b>	<b>150</b>	<b>200</b>
		301.3	309.3	311.1	276.3	280.7	293.3
<b>SST57</b>		321.8	341.3	320.0	287.4	294.8	290.4
<b>SST88</b>		326.2	316.4	329.8	291.1	280.7	283.7



**Analysis of variance**

Source of variation	d.f.	s.s.	m.s.	v.r.	F pr.
<b>REP stratum</b>	2	878.1	439.1	0.73	
<b>REP.CV stratum</b>					
CV	2	2000.7	1000.3	1.67	0.297
Residual	4	2396.3	599.1	1.47	
<b>REP.CV.RW stratum</b>					
RW	1	13330.7	13330.7	32.68	<b>0.001*</b>
CV.RW	2	566.2	283.1	0.69	0.536
Residual	6	2447.5	407.9	0.83	
<b>REP.CV.RW.PD stratum</b>					
PD	2	6993.9	3497.0	7.13	<b>0.004*</b>
CV.PD	4	1086.7	271.7	0.55	0.698
RW.PD	2	963.5	481.8	0.98	0.389
CV.RW.PD	4	1320.2	330.0	0.67	0.617
Residual	24	11774.3	490.6		
<b>Total</b>	53	43758.1			

**Tables of means**

Grand mean: 242.0

<b>CV</b>	<b>SST015</b>	<b>SST57</b>	<b>SST88</b>				
	238.3	250.5	237.0				
<b>RW</b>	<b>250</b>	<b>300</b>					
	257.7	226.3					
<b>PD</b>	<b>150</b>	<b>200</b>	<b>250</b>				
	228.0	242.0	255.9				
<b>CV</b>	<b>RW</b>	<b>250</b>	<b>300</b>				
<b>SST015</b>		258.4	218.3				
<b>SST57</b>		262.8	238.3				
<b>SST88</b>		251.9	222.2				
<b>CV</b>	<b>PD</b>	<b>150</b>	<b>200</b>	<b>250</b>			
<b>SST015</b>		222.9	235.6	256.4			
<b>SST57</b>		242.3	245.3	264.0			
<b>SST88</b>		218.9	245.0	247.3			
<b>RW</b>	<b>PD</b>	<b>150</b>	<b>200</b>	<b>250</b>			
<b>250</b>		238.5	257.8	276.7			
<b>300</b>		217.5	226.2	235.1			
<b>CV</b>	<b>RW</b>	<b>250</b>	<b>200</b>	<b>250</b>	<b>300</b>	<b>200</b>	<b>250</b>
<b>SST015</b>	<b>PD</b>	<b>150</b>	<b>200</b>	<b>250</b>	<b>150</b>	<b>200</b>	<b>250</b>
		239.1	254.2	281.8	206.7	217.0	231.1
<b>SST57</b>		249.8	250.7	288.0	234.8	240.0	240.0
<b>SST88</b>		226.7	268.4	260.4	211.1	221.5	234.1

Analysis of variance

Source of variation	d.f.	s.s.	m.s.	v.r.	F pr.
REP stratum	2	3308.8	1654.4	0.88	
REP.CV stratum					
CV	2	6036.9	3018.5	1.61	0.307
Residual	4	7500.5	1875.1	3.62	
REP.CV.RW stratum					
RW	1	15417.7	15417.7	29.79	0.002*
CV.RW	2	2345.3	1172.7	2.27	0.185
Residual	6	3105.6	517.6	0.90	
REP.CV.RW.PD stratum					
PD	2	15374.1	7687.0	13.39	<.001**
CV.PD	4	1708.3	427.1	0.74	0.572
RW.PD	2	273.1	136.5	0.24	0.790
CV.RW.PD	4	4325.3	1081.3	1.88	0.146
Residual	24	13782.0	574.2		
<b>Total</b>	<b>53</b>	<b>73177.7</b>			

Tables of means

Grand mean: 352.8

CV	<b>SST015</b>	<b>SST57</b>	<b>SST88</b>	
	355.2	364.3	338.8	
RW	<b>250</b>	<b>300</b>		
	369.7	335.9		
PD	<b>100</b>	<b>175</b>	<b>250</b>	
	330.3	357.0	371.0	
CV	RW	<b>250</b>	<b>300</b>	
<b>SST015</b>		373.6	336.8	
<b>SST57</b>		388.4	340.2	
<b>SST88</b>		347.0	330.6	
CV	PD	<b>100</b>	<b>175</b>	<b>250</b>
<b>SST015</b>		322.7	362.2	380.7
<b>SST57</b>		343.3	368.0	381.8
<b>SST88</b>		325.0	340.7	350.7
RW	PD	<b>100</b>	<b>175</b>	<b>250</b>
<b>250</b>		344.9	376.9	387.3
<b>300</b>		315.8	337.0	354.8
CV	RW	<b>250</b>	<b>300</b>	
<b>SST015</b>	PD	<b>100</b>	<b>175</b>	<b>250</b>
<b>SST57</b>		339.6	382.2	399.1
<b>SST88</b>		350.2	398.2	416.9
		344.9	350.2	345.8
			<b>250</b>	<b>300</b>
			<b>100</b>	<b>175</b>
			305.9	342.2
			336.3	337.8
			305.2	331.1
				<b>250</b>
				362.2
				346.7
				355.6

**CVxRWxPD Swellendam 2005  
Heads plant<sup>1</sup>**

**B-6**

**Analysis of variance**

Source of variation	d.f.	s.s.	m.s.	v.r.	F pr.
<b>Rep stratum</b>	2	0.59585	0.29793	2.45	
<b>Rep.CV stratum</b>					
CV	1	0.32150	0.32150	2.64	0.246
Residual	2	0.24345	0.12173	24.16	
<b>Rep.CV.RW stratum</b>					
RW	1	0.03724	0.03724	7.39	0.053
CV.RW	1	0.04394	0.04394	8.72	<b>0.042*</b>
Residual	4	0.02015	0.00504	0.22	
<b>Rep.CV.RW.PD stratum</b>					
PD	2	2.00767	1.00383	43.19	<b>&lt;.001**</b>
CV.PD	2	0.23464	0.11732	5.05	<b>0.020*</b>
RW.PD	2	0.09724	0.04862	2.09	0.156
CV.RW.PD	2	0.03643	0.01821	0.78	0.474
Residual	16	0.37188	0.02324		
<b>Total</b>	35	4.01000			

**Tables of means**

**Grand mean: 0.952**

<b>CV</b>	<b>SST 88</b>	<b>SST 94</b>					
	0.858	1.047					
<b>RW</b>	<b>250</b>	<b>300</b>					
	0.985	0.920					
<b>PD</b>	<b>150</b>	<b>200</b>	<b>250</b>				
	1.218	0.995	0.644				
<b>CV</b>	<b>RW</b>	<b>250</b>	<b>300</b>				
<b>SST 88</b>		0.925	0.791				
<b>SST 94</b>		1.044	1.050				
<b>CV</b>	<b>PD</b>	<b>150</b>	<b>200</b>	<b>250</b>			
<b>SST 88</b>		1.014	0.926	0.633			
<b>SST 94</b>		1.422	1.064	0.656			
<b>RW</b>	<b>PD</b>	<b>150</b>	<b>200</b>	<b>250</b>			
<b>250</b>		1.215	0.989	0.750			
<b>300</b>		1.221	1.001	0.539			
<b>CV</b>	<b>RW</b>	<b>250</b>			<b>300</b>		
<b>SST 88</b>	<b>PD</b>	150	200	250	150	200	250
<b>SST 94</b>		1.086	0.918	0.771	0.942	0.935	0.496
		1.343	1.060	0.729	1.500	1.067	0.582

**CVxRWxPD Caledon 2005  
Heads plant<sup>-1</sup>**

**B-7**

**Analysis of variance**

Source of variation	d.f.	s.s.	m.s.	v.r.	F pr.
<b>Rep stratum</b>	2	0.0851	0.0426	0.27	
<b>Rep.Cul stratum</b>					
Cul	2	0.1704	0.0852	0.54	0.618
Residual	4	0.6273	0.1568	1.03	
<b>Rep.Cul.RW stratum</b>					
RW	1	0.2492	0.2492	1.64	0.248
Cul.RW	2	0.1744	0.0872	0.57	0.592
Residual	6	0.9128	0.1521	1.45	
<b>Rep.Cul.RW.PD stratum</b>					
PD	2	12.5411	6.2706	59.91	<.001**
Cul.PD	4	0.5479	0.1370	1.31	0.295
RW.PD	2	0.0121	0.0061	0.06	0.944
Cul.RW.PD	4	0.0732	0.0183	0.17	0.949
Residual	24	2.5118	0.1047		
<b>Total</b>	53	17.9054			

**Tables of means**

**Grand mean: 1.633**

<b>Cul</b>	<b>SST 57</b>	<b>SST 88</b>	<b>SST 94</b>				
	1.597	1.712	1.590				
<b>RW</b>	<b>250</b>	<b>300</b>					
	1.701	1.565					
<b>PD</b>	<b>100</b>	<b>175</b>	<b>250</b>				
	2.299	1.427	1.173				
<b>Cul</b>	<b>RW</b>	<b>250</b>	<b>300</b>				
<b>SST 57</b>		1.592	1.602				
<b>SST 88</b>		1.787	1.637				
<b>SST 94</b>		1.723	1.456				
<b>Cul</b>	<b>SD</b>	<b>100</b>	<b>175</b>	<b>250</b>			
<b>SST 57</b>		2.206	1.481	1.103			
<b>SST 88</b>		2.560	1.402	1.175			
<b>SST 94</b>		2.130	1.397	1.243			
<b>RW</b>	<b>SD</b>	<b>100</b>	<b>175</b>	<b>250</b>			
<b>250</b>		2.381	1.501	1.221			
<b>300</b>		2.216	1.352	1.126			
<b>Cul</b>	<b>RW</b>	<b>250</b>	<b>175</b>	<b>250</b>	<b>300</b>	<b>175</b>	<b>250</b>
<b>SST 57</b>	<b>SD</b>	<b>100</b>	<b>175</b>	<b>250</b>	<b>100</b>	<b>175</b>	<b>250</b>
		2.284	1.456	1.035	2.129	1.506	1.170
<b>SST 88</b>		2.605	1.484	1.273	2.514	1.320	1.077
<b>SST 94</b>		2.253	1.563	1.354	2.006	1.231	1.132

**CVxRWxPD Riversdale 2006  
Heads plant<sup>1</sup>**

**B-8**

**Analysis of variance**

Source of variation	d.f.	s.s.	m.s.	v.r.	F pr.
<b>Rep stratum</b>		2	1.29233	0.64617	3.67
<b>Rep.CV stratum</b>					
CV	2	0.03194	0.01597	0.09	0.915
Residual	4	0.70416	0.17604	2.15	
<b>Rep.CV.RW stratum</b>					
RW	1	0.02381	0.02381	0.29	0.609
CV.RW	2	0.03743	0.01872	0.23	0.802
Residual	6	0.49061	0.08177	1.24	
<b>Rep.CV.RW.PD stratum</b>					
PD	2	11.75086	5.87543	88.98	<.001**
CV.PD	4	0.31436	0.07859	1.19	0.340
RW.PD	2	0.00493	0.00247	0.04	0.963
CV.RW.PD	4	0.63978	0.15994	2.42	0.076
Residual	24	1.58475	0.06603		
<b>Total</b>	<b>53</b>	<b>16.87496</b>			

**Tables of means**

**Grand mean: 2.057**

<b>CV</b>	<b>SST015</b>	<b>SST57</b>	<b>SST88</b>				
	2.062	2.025	2.083				
<b>RW</b>	<b>250</b>	<b>300</b>					
	2.078	2.036					
<b>PD</b>	<b>100</b>	<b>150</b>	<b>200</b>				
	2.690	1.902	1.579				
<b>CV</b>	<b>RW</b>	<b>250</b>	<b>300</b>				
<b>SST015</b>		2.093	2.032				
<b>SST57</b>		2.010	2.040				
<b>SST88</b>		2.131	2.036				
<b>CV</b>	<b>PD</b>	<b>100</b>	<b>150</b>	<b>200</b>			
<b>SST015</b>		2.603	2.001	1.583			
<b>SST57</b>		2.697	1.907	1.470			
<b>SST88</b>		2.769	1.797	1.685			
<b>RW</b>	<b>PD</b>	<b>100</b>	<b>150</b>	<b>200</b>			
<b>250</b>		2.697	1.931	1.605			
<b>300</b>		2.682	1.872	1.553			
<b>CV</b>	<b>RW</b>	<b>250</b>	<b>150</b>	<b>200</b>	<b>300</b>	<b>150</b>	<b>200</b>
<b>SST015</b>	<b>PD</b>	<b>100</b>	<b>150</b>	<b>200</b>	<b>100</b>	<b>1.987</b>	<b>1.710</b>
		2.809	2.015	1.456	2.398		
<b>SST57</b>		2.622	1.929	1.478	2.772	1.884	1.462
<b>SST88</b>		2.661	1.849	1.881	2.876	1.744	1.488

**Analysis of variance**

Source of variation	d.f.	s.s.	m.s.	v.r.	F pr.
<b>REP stratum</b>	2	0.34816	0.17408	1.54	
<b>REP.CV stratum</b>					
CV	2	0.02776	0.01388	0.12	0.888
Residual	4	0.45289	0.11322	2.38	
<b>REP.CV.RW stratum</b>					
RW	1	0.03981	0.03981	0.84	0.395
CV.RW	2	0.09798	0.04899	1.03	0.412
Residual	6	0.28516	0.04753	1.78	
<b>REP.CV.RW.PD stratum</b>					
PD	2	1.70794	0.85397	31.99	<.001**
CV.PD	4	0.10233	0.02558	0.96	0.448
RW.PD	2	0.09005	0.04502	1.69	0.206
CV.RW.PD	4	0.01328	0.00332	0.12	0.972
Residual	24	0.64060	0.02669		
<b>Total</b>	53	3.80598			

**Tables of means**

Grand mean: 1.208

<b>CV</b>	<b>SST015</b>	<b>SST57</b>	<b>SST88</b>	
	1.240	1.194	1.190	
<b>RW</b>	<b>250</b>	<b>300</b>		
	1.235	1.181		
<b>PD</b>	<b>150</b>	<b>200</b>	<b>250</b>	
	1.443	1.167	1.013	
<b>CV</b>	<b>RW</b>	<b>250</b>	<b>300</b>	
<b>SST015</b>		1.225	1.255	
<b>SST57</b>		1.205	1.182	
<b>SST88</b>		1.275	1.105	
<b>CV</b>	<b>PD</b>	<b>150</b>	<b>200</b>	<b>250</b>
<b>SST015</b>		1.452	1.173	1.094
<b>SST57</b>		1.493	1.111	0.978
<b>SST88</b>		1.385	1.218	0.967
<b>RW</b>	<b>PD</b>	<b>150</b>	<b>200</b>	<b>250</b>
<b>250</b>		1.419	1.243	1.043
<b>300</b>		1.467	1.091	0.983
<b>CV</b>	<b>RW</b>	<b>250</b>	<b>300</b>	
<b>PD</b>		<b>150</b>	<b>200</b>	<b>250</b>
<b>SST015</b>		1.386	1.212	1.075
<b>SST57</b>		1.452	1.145	1.019
<b>SST88</b>		1.419	1.371	1.036
			<b>150</b>	<b>200</b>
			1.518	1.133
			1.533	1.077
			1.350	1.065
				<b>250</b>
				1.114
				0.937
				0.899

**Analysis of variance**

Source of variation	d.f.	s.s.	m.s.	v.r.	F pr.
<b>REP stratum</b>	2	0.29201	0.14600	1.16	
<b>REP.CV stratum</b>					
CV	2	1.03696	0.51848	4.12	0.107
Residual	4	0.50283	0.12571	2.15	
<b>REP.CV.RW stratum</b>					
RW	1	0.00002	0.00002	0.00	0.985
CV.RW	2	0.09653	0.04826	0.83	0.482
Residual	6	0.35000	0.05833	0.75	
<b>REP.CV.RW.PD stratum</b>					
PD	2	24.44096	12.22048	156.85	<.001**
CV.PD	4	0.58256	0.14564	1.87	0.149
RW.PD	2	0.27677	0.13838	1.78	0.191
CV.RW.PD	4	0.77920	0.19480	2.50	0.069
Residual	24	1.86987	0.07791		
<b>Total</b>	53	30.22772			

**Tables of means**

Grand mean: 2.098

<b>CV</b>	<b>SST015</b>	<b>SST57</b>	<b>SST88</b>				
	2.197	2.194	1.902				
<b>RW</b>	<b>250</b>	<b>300</b>					
	2.097	2.098					
<b>PD</b>	<b>100</b>	<b>175</b>	<b>250</b>				
	3.016	1.853	1.424				
<b>CV</b>	<b>RW</b>	<b>250</b>	<b>300</b>				
<b>SST015</b>		2.228	2.165				
<b>SST57</b>		2.134	2.255				
<b>SST88</b>		1.929	1.875				
<b>CV</b>	<b>PD</b>	<b>100</b>	<b>175</b>	<b>250</b>			
<b>SST015</b>		3.026	1.978	1.586			
<b>SST57</b>		3.318	1.871	1.394			
<b>SST88</b>		2.705	1.709	1.291			
<b>RW</b>	<b>PD</b>	<b>100</b>	<b>175</b>	<b>250</b>			
<b>250</b>		2.998	1.947	1.346			
		3.035	1.758	1.502			
<b>CV</b>	<b>RW</b>	<b>250</b>	<b>175</b>	<b>250</b>	<b>300</b>	<b>175</b>	<b>250</b>
<b>SST015</b>	<b>PD</b>	<b>100</b>	<b>175</b>	<b>250</b>	<b>100</b>	<b>175</b>	<b>250</b>
		3.143	2.076	1.465	2.908	1.880	1.707
<b>SST57</b>		3.002	2.003	1.397	3.634	1.740	1.391
<b>SST88</b>		2.848	1.764	1.174	2.561	1.655	1.408

**CVxRWxPD Caledon 2005  
Kernels Head<sup>1</sup>**

**B-11**

**Analysis of variance**

Source of variation	d.f.	s.s.	m.s.	v.r.	F pr.
<b>Rep stratum</b>	2	218.48	109.24	5.97	
<b>Rep.Cul stratum</b>					
Cul	2	43.12	21.56	1.18	0.396
Residual	4	73.24	18.31	0.32	
<b>Rep.Cul.RW stratum</b>					
RW	1	294.45	294.45	5.09	0.065
Cul.RW	2	1.20	0.60	0.01	0.990
Residual	6	346.99	57.83	3.87	
<b>Rep.Cul.RW.PD stratum</b>					
PD	2	390.67	195.34	13.07	<.001**
Cul.PD	4	142.28	35.57	2.38	0.080
RW.PD	2	32.94	16.47	1.10	0.348
Cul.RW.PD	4	57.11	14.28	0.96	0.450
Residual	24	358.62	14.94		
<b>Total</b>	53	1959.10			

**Tables of means**

**Grand mean: 36.19**

<b>Cul</b>	<b>SST 57</b>	<b>SST 88</b>	<b>SST 94</b>				
	36.78	34.92	36.85				
<b>RW</b>	<b>250</b>	<b>300</b>					
	33.85	38.52					
<b>PD</b>	<b>100</b>	<b>175</b>	<b>250</b>				
	39.29	36.53	32.73				
<b>Cul</b>	<b>RW</b>	<b>250</b>	<b>300</b>				
<b>SST 57</b>		34.63	38.93				
<b>SST 88</b>		32.58	37.27				
<b>SST 94</b>		34.34	39.37				
<b>Cul</b>	<b>PD</b>	<b>100</b>	<b>175</b>	<b>250</b>			
<b>SST 57</b>		39.57	36.11	34.67			
<b>SST 88</b>		35.66	36.96	32.15			
<b>SST 94</b>		42.66	36.53	31.37			
<b>RW</b>	<b>PD</b>	<b>100</b>	<b>175</b>	<b>250</b>			
<b>250</b>		36.57	35.29	29.70			
<b>300</b>		42.02	37.78	35.77			
<b>Cul</b>	<b>RW</b>	<b>250</b>	<b>175</b>	<b>250</b>	<b>300</b>	<b>175</b>	<b>250</b>
<b>SST 57</b>	<b>PD</b>	<b>100</b>	<b>175</b>	<b>250</b>	<b>100</b>	<b>175</b>	<b>250</b>
		38.34	35.41	30.15	40.80	36.80	39.18
<b>SST 88</b>		32.42	34.65	30.66	38.89	39.26	33.65
<b>SST 94</b>		38.95	35.80	28.28	46.37	37.26	34.47



**CVxRWxPD Riversdale 2006  
Kernels Head<sup>1</sup>**

**B-12**

**Analysis of variance**

<b>Source of variation</b>	<b>d.f.</b>	<b>s.s.</b>	<b>m.s.</b>	<b>v.r.</b>	<b>F pr.</b>
<b>Rep stratum</b>	2	8.13	4.07	0.83	
<b>Rep.CV stratum</b>					
CV	2	708.08	354.04	72.48	<b>&lt;.001**</b>
Residual	4	19.54	4.88	1.05	
<b>Rep.CV.RW stratum</b>					
RW	1	43.74	43.74	9.38	<b>0.022*</b>
CV.RW	2	10.60	5.30	1.14	0.382
Residual	6	27.99	4.67	0.30	
<b>Rep.CV.RW.PD stratum</b>					
PD	2	9.35	4.68	0.30	0.741
CV.PD	4	40.59	10.15	0.66	0.627
RW.PD	2	1.76	0.88	0.06	0.945
CV.RW.PD	4	132.17	33.04	2.14	0.107
Residual	24	370.20	15.43		
<b>Total</b>	53	1372.16			

**Tables of means**

**Grand mean: 26.77**

<b>CV</b>	<b>SST015</b>	<b>SST57</b>	<b>SST88</b>		
	21.75	28.40	30.16		
<b>RW</b>	<b>250</b>	<b>300</b>			
	25.87	27.67			
<b>PD</b>	<b>100</b>	<b>150</b>	<b>200</b>		
	26.22	27.23	26.85		
<b>CV</b>	<b>RW</b>	<b>250</b>	<b>300</b>		
<b>SST015</b>		21.31	22.18		
<b>SST57</b>		27.63	29.16		
<b>SST88</b>		28.66	31.65		
<b>CV</b>	<b>PD</b>	<b>100</b>	<b>150</b>	<b>200</b>	
<b>SST015</b>		20.42	23.32	21.51	
<b>SST57</b>		29.22	28.32	27.65	
<b>SST88</b>		29.03	30.06	31.38	
<b>RW</b>	<b>PD</b>	<b>100</b>	<b>150</b>	<b>200</b>	
<b>250</b>		25.16	26.58	25.85	
<b>300</b>		27.28	27.88	27.84	
<b>CV</b>	<b>RW</b>	<b>250</b>	<b>150</b>	<b>200</b>	<b>300</b>
<b>SST015</b>	<b>PD</b>	18.68	22.85	22.40	22.15
<b>SST57</b>		31.17	26.30	25.41	27.27
<b>SST88</b>		25.63	30.60	29.75	32.43
				<b>150</b>	<b>200</b>
				23.79	20.62
				30.33	29.89
				29.52	33.01

**Analysis of variance**

Source of variation	d.f.	s.s.	m.s.	v.r.	F pr.
REP stratum	2	61.580	30.790	4.39	
<b>REP.CV stratum</b>					
CV	2	265.340	132.670	18.93	<b>0.009*</b>
Residual	4	28.036	7.009	1.29	
<b>REP.CV.RW stratum</b>					
RW	1	1.973	1.973	0.36	0.568
CV.RW	2	5.967	2.984	0.55	0.603
Residual	6	32.539	5.423	0.88	
<b>REP.CV.RW.PD stratum</b>					
PD	2	54.851	27.426	4.46	<b>0.022*</b>
CV.PD	4	115.210	28.803	4.69	<b>0.006*</b>
RW.PD	2	8.811	4.406	0.72	0.498
CV.RW.PD	4	73.043	18.261	2.97	<b>0.040*</b>
Residual	24	147.426	6.143		
<b>Total</b>	<b>53</b>	<b>794.776</b>			

**Tables of means**

Grand mean: 24.45

<b>CV</b>	<b>SST015</b>	<b>SST57</b>	<b>SST88</b>				
	21.64	24.64	27.06				
<b>RW</b>	<b>250</b>	<b>300</b>					
	24.26	24.64					
<b>PD</b>	<b>150</b>	<b>200</b>	<b>250</b>				
	25.78	24.21	23.35				
<b>CV</b>	<b>RW</b>	<b>250</b>	<b>300</b>				
<b>SST015</b>		21.44	21.84				
<b>SST57</b>		24.05	25.23				
<b>SST88</b>		27.28	26.84				
<b>CV</b>	<b>PD</b>	<b>150</b>	<b>200</b>	<b>250</b>			
<b>SST015</b>		24.78	21.00	19.14			
<b>SST57</b>		23.78	26.49	23.65			
<b>SST88</b>		28.79	25.14	27.25			
<b>RW</b>	<b>PD</b>	<b>150</b>	<b>200</b>	<b>250</b>			
<b>250</b>		25.91	24.27	22.59			
<b>300</b>		25.65	24.15	24.11			
<b>CV</b>	<b>RW</b>	<b>250</b>	<b>200</b>	<b>250</b>	<b>300</b>	<b>200</b>	<b>250</b>
<b>SST015</b>	<b>PD</b>	<b>150</b>	<b>200</b>	<b>250</b>	<b>150</b>	<b>200</b>	<b>250</b>
		25.03	21.39	17.90	24.53	20.62	20.39
<b>SST57</b>		21.61	27.53	23.00	25.95	25.45	24.30
<b>SST88</b>		31.09	23.89	26.86	26.49	26.38	27.64

Analysis of variance

Source of variation	d.f.(mv)	s.s.	m.s.	v.r.	F pr.
REP stratum	2	13.03	6.52	0.22	
REP.CV stratum					
CV	2	496.82	248.41	8.43	<b>0.037*</b>
Residual	4	117.81	29.45	2.52	
REP.CV.RW stratum					
RW	1	18.40	18.40	1.57	0.256
CV.RW	2	0.84	0.42	0.04	0.965
Residual	6	70.11	11.69	0.77	
REP.CV.RW.PD stratum					
PD	2	25.88	12.94	0.85	0.441
CV.PD	4	26.41	6.60	0.43	0.783
RW.PD	2	38.83	19.41	1.27	0.299
CV.RW.PD	4	14.97	3.74	0.25	0.909
Residual	23(1)	350.65	15.25		
<b>Total</b>	<b>52(1)</b>	<b>1116.67</b>			

Tables of means

Grand mean: 30.75

<b>CV</b>	<b>SST015</b>	<b>SST57</b>	<b>SST88</b>				
	26.54	33.58	32.12				
<b>RW</b>	<b>250</b>	<b>300</b>					
	30.16	31.33					
<b>PD</b>	<b>100</b>	<b>175</b>	<b>250</b>				
	30.73	31.60	29.91				
<b>CV</b>	<b>RW</b>	<b>250</b>	<b>300</b>				
<b>SST015</b>		26.10	26.98				
<b>SST57</b>		32.84	34.32				
<b>SST88</b>		31.54	32.69				
<b>CV</b>	<b>SD</b>	<b>100</b>	<b>175</b>	<b>250</b>			
<b>SST015</b>		25.68	27.00	26.94			
<b>SST57</b>		34.04	35.05	31.65			
<b>SST88</b>		32.47	32.76	31.13			
<b>RW</b>	<b>SD</b>	<b>100</b>	<b>175</b>	<b>250</b>			
<b>250</b>		29.57	32.22	28.70			
<b>300</b>		31.89	30.99	31.11			
<b>CV</b>	<b>RW</b>	<b>250</b>	<b>175</b>	<b>250</b>	<b>300</b>	<b>175</b>	<b>250</b>
<b>SST015</b>	<b>SD</b>	<b>100</b>	<b>175</b>	<b>250</b>	<b>100</b>	<b>175</b>	<b>250</b>
		23.83	28.70	25.78	27.52	25.30	28.11
<b>SST57</b>		33.02	35.24	30.26	35.05	34.86	33.05
<b>SST88</b>		31.85	32.71	30.07	33.09	32.81	32.18

**CVxRWxPD Caledon 2005  
Kernel Weight (g 1000 kernels<sup>-1</sup>)**

**B-15**

**Analysis of variance**

Source of variation	d.f.	s.s.	m.s.	v.r.	F pr.
<b>Rep stratum</b>	2	8.4626	4.2313	2.86	
<b>Rep.Cul stratum</b>					
Cul	2	182.2737	91.1369	61.53	<b>&lt;.001**</b>
Residual	4	5.9252	1.4813	1.98	
<b>Rep.Cul.RW stratum</b>					
RW	1	0.0600	0.0600	0.08	0.787
Cul.RW	2	3.8211	1.9106	2.55	0.158
Residual	6	4.4989	0.7498	0.77	
<b>Rep.Cul.RW.PD stratum</b>					
PD	2	0.3915	0.1957	0.20	0.819
Cul.PD	2	1.8433	0.9217	0.95	0.401
Cul.RW.PD	4	2.1022	0.5256	0.54	0.707
Residual	24	23.3133	0.9714		
<b>Total</b>	53	235.0815			

**Tables of means**

**Grand mean: 43.12**

<b>Cul</b>	<b>SST 57</b>	<b>SST 88</b>	<b>SST 94</b>				
	41.80	45.72	41.84				
<b>RW</b>	<b>250</b>	<b>300</b>					
	43.09	43.15					
<b>PD</b>	<b>100</b>	<b>175</b>	<b>250</b>				
	43.06	43.24	43.06				
<b>Cul</b>	<b>RW</b>	<b>250</b>	<b>300</b>				
<b>SST 57</b>		41.53	42.07				
<b>SST 88</b>		46.06	45.38				
<b>SST 94</b>		41.67	42.01				
<b>Cul</b>	<b>PD</b>	<b>100</b>	<b>175</b>	<b>250</b>			
<b>SST 57</b>		41.60	41.80	42.00			
<b>SST 88</b>		45.98	45.88	45.28			
<b>SST 94</b>		41.60	42.03	41.88			
<b>RW</b>	<b>PD</b>	<b>100</b>	<b>175</b>	<b>250</b>			
<b>250</b>		43.06	42.97	43.23			
<b>300</b>		43.07	43.51	42.88			
<b>Cul</b>	<b>RW</b>	<b>250</b>	<b>300</b>	<b>175</b>	<b>250</b>		
<b>SST 57</b>	<b>PD</b>	<b>100</b>	<b>100</b>	<b>175</b>	<b>100</b>	<b>175</b>	<b>250</b>
		41.23	41.17	42.20	41.97	42.43	41.80
<b>SST 88</b>		46.67	45.87	45.63	45.30	45.90	44.93
<b>SST 94</b>		41.27	41.87	41.87	41.93	42.20	41.90

**CVxRWxPD Riversdale 2006  
Kernel Weight (g 1000 kernels<sup>-1</sup>)**

**B-16**

**Analysis of variance**

Source of variation	d.f.	s.s.	m.s.	v.r.	F pr.
<b>Rep stratum</b>		2	62.558	31.279	15.23
<b>Rep.CV stratum</b>					
CV	2	1214.674	607.337	295.75	<.001**
Residual	4	8.214	2.054	5.29	
<b>Rep.CV.RW stratum</b>					
RW	1	2.622	2.622	6.76	0.041*
CV.RW	2	1.318	0.659	1.70	0.260
Residual	6	2.328	0.388	0.16	
<b>Rep.CV.RW.PD stratum</b>					
PD	2	8.451	4.226	1.69	0.205
CV.PD	4	40.581	10.145	4.06	0.012*
RW.PD	2	5.060	2.530	1.01	0.378
CV.RW.PD	4	12.421	3.105	1.24	0.319
Residual	24	59.933	2.497		
<b>Total</b>	<b>53</b>	<b>1418.161</b>			

**Tables of means**

**Grand mean: 41.21**

<b>CV</b>	<b>SST015</b>	<b>SST57</b>	<b>SST88</b>				
	45.98	34.74	42.91				
<b>RW</b>	<b>250</b>	<b>300</b>					
	40.99	41.43					
<b>PD</b>	<b>100</b>	<b>150</b>	<b>200</b>				
	41.45	40.66	41.53				
<b>CV</b>	<b>RW</b>	<b>250</b>	<b>300</b>				
<b>SST015</b>		45.67	46.30				
<b>SST57</b>		34.40	35.09				
<b>SST88</b>		42.91	42.91				
<b>CV</b>	<b>PD</b>	<b>100</b>	<b>150</b>	<b>200</b>			
<b>SST015</b>		47.88	44.80	45.27			
<b>SST57</b>		34.50	34.43	35.30			
<b>SST88</b>		41.97	42.73	44.03			
<b>RW</b>	<b>PD</b>	<b>100</b>	<b>150</b>	<b>200</b>			
<b>250</b>		41.18	40.09	41.71			
<b>300</b>		41.72	41.22	41.36			
<b>CV</b>	<b>RW</b>	<b>250</b>	<b>150</b>	<b>200</b>	<b>300</b>	<b>150</b>	<b>200</b>
<b>SST015</b>	<b>PD</b>	47.60	44.00	45.40	48.17	45.60	45.13
<b>SST57</b>		33.87	34.60	34.73	35.13	34.27	35.87
<b>SST88</b>		42.07	41.67	45.00	41.87	43.80	43.07

Analysis of variance

Source of variation	d.f.	s.s.	m.s.	v.r.	F pr.
REP stratum	2	1.618	0.809	0.60	
REP.CV stratum					
CV	2	1509.231	754.616	557.14	<.001**
Residual	4	5.418	1.354	0.87	
REP.CV.RW stratum					
RW	1	0.001	0.001	0.00	0.983
CV.RW	2	1.166	0.583	0.38	0.701
Residual	6	9.293	1.549	0.98	
REP.CV.RW.PD stratum					
PD	2	4.084	2.042	1.29	0.293
CV.PD	4	8.418	2.104	1.33	0.286
RW.PD	2	0.250	0.125	0.08	0.924
CV.RW.PD	4	3.576	0.894	0.57	0.689
Residual	24	37.884	1.579		
<b>Total</b>	<b>53</b>	<b>1580.940</b>			

Tables of means

Grand mean: 37.37

<b>CV</b>	<b>SST015</b>	<b>SST57</b>	<b>SST88</b>				
	39.94	30.00	42.16				
<b>RW</b>	<b>250</b>	<b>300</b>					
	37.37	37.36					
<b>PD</b>	<b>150</b>	<b>200</b>	<b>250</b>				
	37.76	37.17	37.18				
<b>CV</b>	<b>RW</b>	<b>250</b>	<b>300</b>				
<b>SST015</b>		40.16	39.73				
<b>SST57</b>		29.91	30.09				
<b>SST88</b>		42.04	42.27				
<b>CV</b>	<b>PD</b>	<b>150</b>	<b>200</b>	<b>250</b>			
<b>SST015</b>		40.57	39.07	40.20			
<b>SST57</b>		30.17	30.47	29.37			
<b>SST88</b>		42.53	41.97	41.97			
<b>RW</b>	<b>PD</b>	<b>150</b>	<b>200</b>	<b>250</b>			
<b>250</b>		37.76	37.09	37.27			
<b>300</b>		37.76	37.24	37.09			
<b>CV</b>	<b>RW</b>	<b>250</b>	<b>200</b>	<b>250</b>	<b>300</b>	<b>200</b>	<b>250</b>
<b>SST015</b>	<b>PD</b>	<b>150</b>	<b>200</b>	<b>250</b>	<b>150</b>	<b>200</b>	<b>250</b>
		40.87	39.53	40.07	40.27	38.60	40.33
<b>SST57</b>		30.20	29.93	29.60	30.13	31.00	29.13
<b>SST88</b>		42.20	41.80	42.13	42.87	42.13	41.80

Analysis of variance

Source of variation	d.f.	s.s.	m.s.	v.r.	F pr.
REP stratum	2	18.464	9.232	0.85	
REP.CV stratum					
CV	2	1223.388	611.694	56.58	<b>0.001*</b>
Residual	4	43.247	10.812	2.81	
REP.CV.RW stratum					
RW	1	1.567	1.567	0.41	0.547
CV.RW	2	12.926	6.463	1.68	0.264
Residual	6	23.107	3.851	3.21	
REP.CV.RW.PD stratum					
PD	2	28.668	14.334	11.95	<b>&lt;.001**</b>
CV.PD	4	2.630	0.657	0.55	0.702
RW.PD	2	5.086	2.543	2.12	0.142
CV.RW.PD	4	3.501	0.875	0.73	0.580
Residual	24	28.782	1.199		
<b>Total</b>	<b>53</b>	<b>1391.366</b>			

Tables of means

Grand mean: 41.16

<b>CV</b>	<b>SST015</b>	<b>SST57</b>	<b>SST88</b>				
	46.59	35.00	41.90				
<b>RW</b>	<b>250</b>	<b>300</b>					
	41.33	40.99					
<b>PD</b>	<b>100</b>	<b>175</b>	<b>250</b>				
	42.19	40.73	40.57				
<b>CV</b>	<b>RW</b>	<b>250</b>	<b>300</b>				
<b>SST015</b>		46.33	46.84				
<b>SST57</b>		34.91	35.09				
<b>SST88</b>		42.76	41.04				
<b>CV</b>	<b>PD</b>	<b>100</b>	<b>175</b>	<b>250</b>			
<b>SST015</b>		47.60	45.80	46.37			
<b>SST57</b>		35.93	34.83	34.23			
<b>SST88</b>		43.03	41.57	41.10			
<b>RW</b>	<b>PD</b>	<b>100</b>	<b>175</b>	<b>250</b>			
<b>250</b>		41.93	41.04	41.02			
<b>300</b>		42.44	40.42	40.11			
<b>CV</b>	<b>RW</b>	<b>250</b>	<b>175</b>	<b>250</b>	<b>300</b>	<b>175</b>	<b>250</b>
<b>SST015</b>	<b>PD</b>	<b>100</b>	<b>175</b>	<b>250</b>	<b>100</b>	<b>175</b>	<b>250</b>
		46.73	45.53	46.73	48.47	46.07	46.00
<b>SST57</b>		35.47	35.27	34.00	36.40	34.40	34.47
<b>SST88</b>		43.60	42.33	42.33	42.47	40.80	39.87

**CVxRWxPD Riversdale 2004  
Grain Yield (ton ha<sup>-1</sup>)**

**C-1**

**Analysis of variance**

<b>Source of variation</b>	<b>d.f.(mv)</b>	<b>s.s.</b>	<b>m.s.</b>	<b>v.r.</b>	<b>F pr.</b>
<b>REP stratum</b>	2	0.2697	0.1349	0.35	
<b>REP.WPLOT stratum</b>					
CULT	1	0.8944	0.8944	2.34	0.265
Residual	2	0.7630	0.3815	5.94	
<b>REP.WPLOT.SPLOT stratum</b>					
RW	1	0.0179	0.0179	0.28	0.625
CULT.RW	1	0.3889	0.3889	6.06	0.070
Residual	4	0.2569	0.0642	0.18	
<b>REP.WPLOT.SPLOT.SSPLOT stratum</b>					
PD	2	0.6814	0.3407	0.93	0.417
CULT.PD	2	1.9200	0.9600	2.62	0.108
RW.PD	2	0.5327	0.2663	0.73	0.500
CULT.RW.PD	2	0.5737	0.2868	0.78	0.476
Residual	14(2)	5.1236	0.3660		
<b>Total</b>	33(2)	11.2009			

**Tables of means**

**Grand mean: 3.00**

<b>CULT</b>	<b>SST88</b>	<b>SST94</b>					
	3.16	2.84					
<b>RW</b>	<b>250</b>	<b>300</b>					
	2.98	3.02					
<b>PD</b>	<b>100</b>	<b>150</b>	<b>200</b>				
	3.07	2.81	3.13				
<b>CULT</b>	<b>RW</b>	<b>250</b>	<b>300</b>				
<b>SST88</b>		3.24	3.08				
<b>SST94</b>		2.72	2.97				
<b>CULT</b>	<b>PD</b>	<b>100</b>	<b>150</b>	<b>200</b>			
<b>SST88</b>		2.91	3.21	3.36			
<b>SST94</b>		3.22	2.42	2.90			
<b>RW</b>	<b>PD</b>	<b>100</b>	<b>150</b>	<b>200</b>			
<b>250</b>		2.89	2.80	3.25			
<b>300</b>		3.24	2.82	3.01			
<b>CULT</b>	<b>RW</b>	<b>250</b>	<b>150</b>	<b>200</b>	<b>300</b>	<b>150</b>	<b>200</b>
<b>SST88</b>	<b>PD</b>	2.67	3.33	3.72	3.15	3.08	3.00
<b>SST94</b>		3.11	2.26	2.78	3.33	2.57	3.01



**CVxRWxPD Riversdale 2006  
Grain Yield (ton ha<sup>-1</sup>)**

**C-2**

**Analysis of variance**

Source of variation	d.f.(mv)	s.s.	m.s.	v.r.	F pr.
<b>Rep stratum</b>	2	0.32502	0.1625	11.21	
<b>Rep.CV stratum</b>					
CV	2	11.09243	5.54622	41.45	<b>0.002*</b>
Residual	4	0.53518	0.13379	1.23	
<b>Rep.CV.RW stratum</b>					
RW	1	0.38477	0.38477	3.55	0.108
CV.RW	2	0.10659	0.05329	0.49	0.634
Residual	6	0.65011	0.10835	1.48	
<b>Rep.CV.RW.PD stratum</b>					
PD	2	0.04875	0.02438	0.33	0.721
CV.PD	4	0.37356	0.09339	1.27	0.314
RW.PD	2	0.13329	0.06664	0.91	0.420
CV.RW.PD	4	0.56579	0.14145	1.93	0.145
Residual	20(4)	1.46874	0.07344		
<b>Total</b>	49(4)	14.78377			

**Tables of means**

**Grand mean: 3.362**

<b>CV</b>	<b>SST015</b>	<b>SST57</b>	<b>SST88</b>				
	3.047	3.036	4.003				
<b>RW</b>	<b>250</b>	<b>300</b>					
	3.446	3.278					
<b>PD</b>	<b>100</b>	<b>150</b>	<b>200</b>				
	3.352	3.331	3.403				
<b>CV</b>	<b>RW</b>	<b>250</b>	<b>300</b>				
<b>SST015</b>		3.119	2.976				
<b>SST57</b>		3.073	2.998				
<b>SST88</b>		4.147	3.859				
<b>CV</b>	<b>PD</b>	<b>100</b>	<b>150</b>	<b>200</b>			
<b>SST015</b>		3.021	3.063	3.058			
<b>SST57</b>		3.033	3.101	2.972			
<b>SST88</b>		4.002	3.829	4.178			
<b>RW</b>	<b>PD</b>	<b>100</b>	<b>150</b>	<b>200</b>			
<b>250</b>		3.506	3.391	3.442			
<b>300</b>		3.198	3.271	3.363			
<b>CV</b>	<b>RW</b>	<b>250</b>	<b>150</b>	<b>200</b>	<b>300</b>	<b>150</b>	<b>200</b>
<b>SST015</b>	<b>PD</b>	3.096	3.107	3.153	2.946	3.020	2.963
<b>SST57</b>		3.335	3.054	2.831	2.730	3.149	3.114
<b>SST88</b>		4.085	4.013	4.343	3.918	3.645	4.013

**CVxRWxPD Riversdale 2004  
Protein (%)**

**C-3**

**Analysis of variance**

Source of variation	d.f.(mv)	s.s.	m.s.	v.r.	F pr.
<b>REP stratum</b>	2	0.15638	0.07819	1.81	
<b>REP.WPLOT stratum</b>					
CULT	1	2.26723	2.26723	52.39	<b>0.019*</b>
Residual	2	0.08655	0.04328	0.33	
<b>REP.WPLOT.SPLOT stratum</b>					
RW	1	0.86670	0.86670	6.65	0.061
CULT.RW	1	0.12023	0.12023	0.92	0.391
Residual	4	0.52133	0.13033	2.87	
<b>REP.WPLOT.SPLOT.SSPLOT stratum</b>					
PD	2	0.14492	0.07246	1.60	0.237
CULT.PD	2	0.72190	0.36095	7.96	<b>0.005*</b>
RW.PD	2	0.30035	0.15018	3.31	0.066
CULT.RW.PD	2	0.30636	0.15318	3.38	0.064
Residual	14(2)	0.63495	0.04535		
<b>Total</b>	33(2)	5.20232			

**Tables of means**

**Grand mean: 11.822**

<b>CULT</b>	<b>SST88</b>	<b>SST94</b>					
	12.073	11.571					
<b>RW</b>	<b>250</b>	<b>300</b>					
	11.977	11.667					
<b>PD</b>	<b>100</b>	<b>150</b>	<b>200</b>				
	11.835	11.892	11.738				
<b>CULT</b>	<b>RW</b>	<b>250</b>	<b>300</b>				
<b>SST88</b>		12.170	11.975				
<b>SST94</b>		11.784	11.358				
<b>CULT</b>	<b>PD</b>	<b>100</b>	<b>150</b>	<b>200</b>			
<b>SST88</b>		12.273	12.114	11.832			
<b>SST94</b>		11.398	11.670	11.644			
<b>RW</b>	<b>PD</b>	<b>100</b>	<b>150</b>	<b>200</b>			
<b>250</b>		11.914	12.175	11.842			
<b>300</b>		11.757	11.608	11.634			
<b>CULT</b>	<b>RW</b>	<b>250</b>	<b>150</b>	<b>200</b>	<b>300</b>	<b>150</b>	<b>200</b>
<b>SST88</b>	<b>PD</b>	12.328	12.430	11.752	12.217	11.797	11.912
<b>SST94</b>		11.499	11.920	11.932	11.298	11.420	11.356

**CVxRWxPD Riversdale 2006  
Protein (%)**

**C-4**

**Analysis of variance**

Source of variation	d.f.	s.s.	m.s.	v.r.	F pr.
<b>Rep stratum</b>	2	0.8306	0.4153	1.59	
<b>Rep.CV stratum</b>					
CV	2	4.9639	2.4820	9.47	<b>0.030*</b>
Residual	4	1.0479	0.2620	1.84	
<b>Rep.CV.RW stratum</b>					
RW	1	0.0504	0.0504	0.35	0.574
CV.RW	2	0.2594	0.1297	0.91	0.452
Residual	6	0.8559	0.1427	0.71	
<b>Rep.CV.RW.PD stratum</b>					
PD	2	0.2251	0.1125	0.56	0.578
CV.PD	4	0.7105	0.1776	0.89	0.488
RW.PD	2	0.8055	0.4027	2.01	0.156
CV.RW.PD	4	0.8916	0.2229	1.11	0.374
Residual	24	4.8151	0.2006		
<b>Total</b>	<b>53</b>	<b>15.4559</b>			

**Tables of means**

**Grand mean: 10.954**

<b>CV</b>	<b>SST015</b>	<b>SST57</b>	<b>SST88</b>					
	11.316	10.972	10.574					
<b>RW</b>	<b>250</b>	<b>300</b>						
	10.923	10.984						
<b>PD</b>	<b>100</b>	<b>150</b>	<b>200</b>					
	11.042	10.890	10.929					
<b>CV</b>	<b>RW</b>	<b>250</b>	<b>300</b>					
<b>SST015</b>		11.188	11.444					
<b>SST57</b>		10.998	10.946					
<b>SST88</b>		10.584	10.564					
<b>CV</b>	<b>PD</b>	<b>100</b>	<b>150</b>	<b>200</b>				
<b>SST015</b>		11.339	11.132	11.476				
<b>SST57</b>		11.055	10.895	10.966				
<b>SST88</b>		10.733	10.644	10.344				
<b>RW</b>	<b>PD</b>	<b>100</b>	<b>150</b>	<b>200</b>				
<b>250</b>		11.184	10.759	10.827				
<b>300</b>		10.901	11.021	11.031				
<b>CV</b>	<b>RW</b>	<b>250</b>	<b>300</b>		<b>100</b>	<b>150</b>	<b>200</b>	
<b>SST015</b>	<b>PD</b>	<b>100</b>	<b>150</b>	<b>200</b>	11.156	11.277	11.899	
<b>SST57</b>		11.523	10.986	11.054	11.010	11.028	10.800	
<b>SST88</b>		11.100	10.762	11.133	10.537	10.759	10.394	

**CVxRWxPD Riversdale 2004  
Hectolitre Mass (kg hl<sup>-1</sup>)**

**C-5**

**Analysis of variance**

<b>Source of variation</b>	<b>d.f.(mv)</b>	<b>s.s.</b>	<b>m.s.</b>	<b>v.r.</b>	<b>F pr.</b>
<b>REP stratum</b>	2	1.7390	0.8695	1.53	
<b>REP.WPLOT stratum</b>					
CULT	1	31.4945	31.4945	55.47	<b>0.018*</b>
Residual	2	1.1355	0.5677	2.37	
<b>REP.WPLOT.SPLOT stratum</b>					
RW	1	0.1211	0.1211	0.51	0.517
CULT.RW	1	0.6593	0.6593	2.75	0.173
Residual	4	0.9590	0.2398	0.46	
<b>REP.WPLOT.SPLOT.SSPLOT stratum</b>					
PD	2	1.1539	0.5769	1.10	0.361
CULT.PD	2	4.2028	2.1014	3.99	<b>0.042*</b>
RW.PD	2	0.4281	0.2140	0.41	0.673
CULT.RW.PD	2	0.5696	0.2848	0.54	0.594
Residual	14(2)	7.3687	0.5263		
Total	33(2)	47.5350			

**Tables of means**

**Grand mean: 78.25**

<b>CULT</b>	<b>SST88</b>	<b>SST94</b>					
	79.19	7.32					
<b>RW</b>	<b>250</b>	<b>300</b>					
	78.19	78.31					
<b>PD</b>	<b>100</b>	<b>150</b>	<b>200</b>				
	78.22	78.49	78.05				
<b>CULT</b>	<b>RW</b>	<b>250</b>	<b>300</b>				
<b>SST88</b>		78.99	79.38				
<b>SST94</b>		77.39	77.24				
<b>CULT</b>	<b>PD</b>	<b>100</b>	<b>150</b>	<b>200</b>			
<b>SST88</b>		79.37	79.69	78.50			
<b>SST94</b>		77.07	77.28	77.60			
<b>RW</b>	<b>PD</b>	<b>100</b>	<b>150</b>	<b>200</b>			
<b>250</b>		78.31	78.39	77.88			
<b>300</b>	78.13	78.58	78.22				
<b>RW</b>		<b>250</b>			<b>300</b>		
<b>CULT</b>	<b>PD</b>	<b>100</b>	<b>150</b>	<b>200</b>	<b>100</b>	<b>150</b>	<b>200</b>
<b>SST88</b>		79.49	79.43	78.06	79.25	79.95	78.95
<b>SST94</b>		77.13	77.34	77.71	77.01	77.22	77.49

**CVxRWxPD Riversdale 2006  
Hectolitre Mass (kg hl<sup>-1</sup>)**

**C-6**

**Analysis of variance**

Source of variation	d.f.	s.s.	m.s.	v.r.	F pr.
<b>Rep stratum</b>	2	4.0237	2.0119	3.02	
<b>Rep.CV stratum</b>					
CV	2	84.1081	42.0541	63.12	<.001**
Residual	4	2.6652	0.6663	1.03	
<b>Rep.CV.RW stratum</b>					
RW	1	0.2963	0.2963	0.46	0.523
CV.RW	2	0.1526	0.0763	0.12	0.890
Residual	6	3.8711	0.6452	1.00	
<b>Rep.CV.RW.PD stratum</b>					
PD	2	0.5970	0.2985	0.46	0.636
CV.PD	4	0.0652	0.0163	0.03	0.999
RW.PD	2	0.5881	0.2941	0.45	0.640
CV.RW.PD	4	1.8430	0.4607	0.71	0.591
Residual	24	15.5200	0.6467		
<b>Total</b>	53	113.7304			

**Tables of means**

**Grand mean: 77.06**

<b>CV</b>	<b>SST015</b>	<b>SST57</b>	<b>SST88</b>				
	76.63	75.79	78.76				
<b>RW</b>	<b>250</b>	<b>300</b>					
	76.99	77.13					
<b>PD</b>	<b>100</b>	<b>150</b>	<b>200</b>				
	76.91	77.14	77.12				
<b>CV</b>	<b>RW</b>	<b>250</b>	<b>300</b>				
<b>SST015</b>		76.53	76.73				
<b>SST57</b>		75.67	75.91				
<b>SST88</b>		78.76	78.76				
<b>CV</b>	<b>PD</b>	<b>100</b>	<b>150</b>	<b>200</b>			
<b>SST015</b>		76.43	76.77	76.70			
<b>SST57</b>		75.63	75.87	75.87			
<b>SST88</b>		78.67	78.80	78.80			
<b>RW</b>	<b>PD</b>	<b>100</b>	<b>150</b>	<b>200</b>			
<b>250</b>		76.71	77.20	77.04			
<b>300</b>		77.11	77.09	77.20			
<b>CV</b>	<b>RW</b>	<b>250</b>	<b>150</b>	<b>200</b>	<b>300</b>	<b>150</b>	<b>200</b>
<b>SST015</b>	<b>PD</b>	76.07	76.80	76.73	76.80	76.73	76.67
<b>SST57</b>		75.73	75.80	75.47	75.53	75.93	76.27
<b>SST88</b>		78.33	79.00	78.93	79.00	78.60	78.67

**CVxRWxPD Swellendam 2004  
Grain Yield (ton ha<sup>-1</sup>)**

**C-7**

**Analysis of variance**

Source of variation	d.f.	s.s.	m.s.	v.r.	F pr.
<b>REP stratum</b>	2	0.00940	0.00470	0.08	
<b>REP.WPLOT stratum</b>					
CULT	2	0.24721	0.12361	2.21	0.226
Residual	4	0.22404	0.05601	0.83	
<b>REP.WPLOT.SPLOT stratum</b>					
RW	1	0.02884	0.02884	0.42	0.539
CULT.RW	2	0.23021	0.11511	1.70	0.261
Residual	6	0.40725	0.06788	1.53	
<b>REP.WPLOT.SPLOT.SSPLOT stratum</b>					
PD	2	0.00299	0.00150	0.03	0.967
CULT.PD	4	0.13697	0.03424	0.77	0.553
RW.PD	2	0.03643	0.01822	0.41	0.667
CULT.RW.PD	4	0.06684	0.01671	0.38	0.823
Residual	24	1.06314	0.04430		
<b>Total</b>	53	2.45333			

**Tables of means**

**Grand mean: 1.778**

<b>CULT</b>	<b>SST57</b>	<b>SST88</b>	<b>SST94</b>				
	1.711	1.754	1.871				
<b>RW</b>	<b>250</b>	<b>300</b>					
	1.801	1.755					
<b>PD</b>	<b>150</b>	<b>200</b>	<b>250</b>				
	1.769	1.787	1.778				
<b>CULT</b>	<b>RW</b>	<b>250</b>	<b>300</b>				
<b>SST57</b>		1.813	1.608				
<b>SST88</b>		1.777	1.730				
<b>SST94</b>		1.814	1.928				
<b>CULT</b>	<b>PD</b>	<b>150</b>	<b>200</b>	<b>250</b>			
<b>SST57</b>		1.722	1.730	1.680			
<b>SST88</b>		1.789	1.676	1.795			
<b>SST94</b>		1.797	1.956	1.860			
<b>RW</b>	<b>PD</b>	<b>150</b>	<b>200</b>	<b>250</b>			
<b>250</b>		1.807	1.774	1.823			
<b>300</b>		1.731	1.801	1.734			
<b>RW</b>		<b>250</b>			<b>300</b>		
<b>CULT</b>	<b>PD</b>	<b>150</b>	<b>200</b>	<b>250</b>	<b>150</b>	<b>200</b>	<b>250</b>
<b>SST57</b>		1.824	1.755	1.862	1.620	1.705	1.498
<b>SST88</b>		1.866	1.658	1.808	1.712	1.695	1.783
<b>SST94</b>		1.732	1.909	1.800	1.861	2.002	1.919

**CVxRWxPD Swellendam 2005  
Grain Yield (ton ha<sup>-1</sup>)**

**C-8**

**Analyses of variance**

<b>Source of variation</b>	<b>d.f.</b>	<b>s.s.</b>	<b>m.s.</b>	<b>v.r.</b>	<b>F pr.</b>
<b>Rep stratum</b>	2	0.57805	0.28902	2.79	
<b>Rep.CV stratum</b>					
CV	1	0.13460	0.13460	1.30	0.372
Residual	2	0.20705	0.10352	4.75	
<b>Rep.CV.RW stratum</b>					
RW	1	0.00610	0.00610	0.28	0.625
CV.RW	1	0.05254	0.05254	2.41	0.195
Residual	4	0.08710	0.02177	0.81	
<b>Rep.CV.RW.PD stratum</b>					
PD	2	0.03627	0.01814	0.68	0.523
CV.PD	2	0.03943	0.01972	0.73	0.495
RW.PD	2	0.10936	0.05468	2.04	0.163
CV.RW.PD	2	0.01674	0.00837	0.31	0.737
Residual	16	0.42965	0.02685		
<b>Total</b>	35	1.69688			

**Tables of means**

**Grand mean: 0.856**

<b>CV</b>	<b>SST 88</b>	<b>SST 94</b>					
	0.795	0.918					
<b>RW</b>	<b>250</b>	<b>300</b>					
	0.869	0.843					
<b>PD</b>	<b>150</b>	<b>200</b>	<b>250</b>				
	0.853	0.819	0.897				
<b>CV</b>	<b>RW</b>	<b>250</b>	<b>300</b>				
<b>SST 88</b>		0.847	0.744				
<b>SST 94</b>		0.892	0.943				
<b>CV</b>	<b>PD</b>	<b>150</b>	<b>200</b>	<b>250</b>			
<b>SST 88</b>		0.745	0.783	0.858			
<b>SST 94</b>		0.961	0.856	0.936			
<b>RW</b>	<b>PD</b>	<b>150</b>	<b>200</b>	<b>250</b>			
<b>250</b>		0.933	0.764	0.912			
<b>300</b>		0.774	0.875	0.882			
<b>CV</b>	<b>RW</b>	<b>250</b>			<b>300</b>		
<b>SST 88</b>	<b>PD</b>	<b>150</b>	<b>200</b>	<b>250</b>	<b>150</b>	<b>200</b>	<b>250</b>
		0.851	0.747	0.941	0.639	0.818	0.775
<b>SST 94</b>		1.014	0.781	0.882	0.908	0.931	0.989

**CVxRWxPD Swellendam 2006  
Grain Yield (ton ha<sup>-1</sup>)**

**C-9**

**Analysis of variance**

Source of variation	d.f.(mv)	s.s.	m.s.	v.r.	F pr.
<b>REP stratum</b>	2	0.27568	0.13784	19.33	
<b>REP.CV stratum</b>					
CV	2	6.89248	3.44624	483.26	<b>&lt;.001**</b>
Residual	4	0.02852	0.00713	0.19	
<b>REP.CV.RW stratum</b>					
RW		0.86379	0.86379	22.85	<b>0.003*</b>
CV.RW		0.16492	0.08246	2.18	0.194
Residual		0.22677	0.03780	0.64	
<b>REP.CV.RW.PDstratum</b>					
PD	2	0.04373	0.02186	0.37	0.693
CV.PD	4	0.57129	0.14282	2.43	0.077
RW.PD	2	0.01275	0.00637	0.11	0.898
CV.RW.PD	4	0.34391	0.08598	1.46	0.246
Residual	23(1)	1.35117	0.05875		
<b>Total</b>	52(1)	10.52034			

**Tables of means**

**Grand mean: 2.192**

<b>CV</b>	<b>SST015</b>	<b>SST57</b>	<b>SST88</b>				
	2.038	1.852	2.686				
<b>RW</b>	<b>250</b>	<b>300</b>					
	2.318	2.065					
<b>PD</b>	<b>150</b>	<b>200</b>	<b>250</b>				
	2.223	2.154	2.199				
<b>CV</b>	<b>RW</b>	<b>250</b>	<b>300</b>				
<b>SST015</b>		2.195	1.881				
<b>SST57</b>		1.901	1.803				
<b>SST88</b>		2.859	2.512				
<b>CV</b>	<b>PD</b>	<b>150</b>	<b>200</b>	<b>250</b>			
<b>SST015</b>		2.222	1.938	1.954			
<b>SST57</b>		1.767	1.961	1.828			
<b>SST88</b>		2.678	2.563	2.815			
<b>RW</b>	<b>PD</b>	<b>150</b>	<b>200</b>	<b>250</b>			
<b>250</b>		2.361	2.290	2.304			
<b>300</b>		2.084	2.018	2.095			
<b>CV</b>	<b>RW</b>	<b>250</b>	<b>200</b>	<b>250</b>	<b>300</b>	<b>200</b>	<b>250</b>
<b>SST015</b>	<b>PD</b>	<b>150</b>	<b>200</b>	<b>250</b>	<b>150</b>	<b>200</b>	<b>250</b>
		2.416	2.148	2.020	2.029	1.727	1.888
<b>SST57</b>		1.691	2.055	1.957	1.843	1.867	1.699
<b>SST88</b>		2.975	2.668	2.935	2.381	2.458	2.696



**Analysis of variance**

Source of variation	d.f.	s.s.	m.s.	v.r.	F pr.
<b>REP stratum</b>	2	0.4121	0.2060	1.14	
<b>REP.WPLOT stratum</b>					
CULT	2	0.7897	0.3949	2.18	0.229
Residual	4	0.7233	0.1808	1.17	
<b>REP.WPLOT.SPLOT stratum</b>					
RW	1	0.2698	0.2698	1.74	0.235
CULT.RW	2	0.0402	0.0201	0.13	0.881
Residual	6	0.9285	0.1548	0.63	
<b>REP.WPLOT.SPLOT.SSPLOT stratum</b>					
PD	2	0.4713	0.2357	0.95	0.399
CULT.PD	4	0.2935	0.0734	0.30	0.877
RW.PD	2	0.2029	0.1015	0.41	0.668
CULT.RW.PD	4	1.0074	0.2519	1.02	0.417
Residual	24	5.9281	0.2470		
Total	53	11.0669			

**Tables of means**

Grand mean: 11.200

<b>CULT</b>	<b>SST57</b>	<b>SST88</b>	<b>SST94</b>				
	11.207	11.344	11.049				
<b>RW</b>	<b>250</b>	<b>300</b>					
	11.129	11.271					
<b>PD</b>	<b>150</b>	<b>200</b>	<b>250</b>				
	11.313	11.085	11.202				
<b>CULT</b>	<b>RW</b>	<b>250</b>	<b>300</b>				
<b>SST57</b>		11.139	11.275				
<b>SST88</b>		11.239	11.450				
<b>SST94</b>		11.010	11.087				
<b>CULT</b>	<b>PD</b>	<b>150</b>	<b>200</b>	<b>250</b>			
<b>SST57</b>		11.379	10.950	11.291			
<b>SST88</b>		11.426	11.332	11.276			
<b>SST94</b>		11.135	10.972	11.039			
<b>RW</b>	<b>PD</b>	<b>150</b>	<b>200</b>	<b>250</b>			
<b>250</b>		11.291	10.927	11.169			
<b>300</b>		11.335	11.242	11.235			
<b>CULT</b>	<b>RW</b>	<b>250</b>	<b>200</b>	<b>250</b>	<b>300</b>	<b>200</b>	<b>250</b>
<b>SST57</b>	<b>PD</b>	<b>150</b>	<b>200</b>	<b>250</b>	<b>150</b>	<b>10.998</b>	<b>11.391</b>
		11.322	10.903	11.191	11.436		
<b>SST88</b>		11.276	10.982	11.460	11.576	11.681	11.092
<b>SST94</b>		11.277	10.897	10.855	10.994	11.046	11.222

**Analysis of variance**

Source of variation	d.f.	s.s.	m.s.	v.r.	F pr.
REP stratum	2	0.04716	0.02358	0.18	
REP.CV stratum					
CV	2	5.83551	2.91775	22.60	<b>0.007*</b>
Residual	4	0.51637	0.12909	4.75	
REP.CV.RW stratum					
RW	1	0.13180	0.13180	4.85	0.070
CV.RW	2	0.32773	0.16387	6.03	<b>0.037*</b>
Residual	6	0.16316	0.02719	0.54	
REP.CV.RW.PD stratum					
PD	2	0.16525	0.08262	1.63	0.216
CV.PD	4	0.33358	0.08340	1.65	0.195
RW.PD	2	0.06510	0.03255	0.64	0.534
CV.RW.PD	4	0.45704	0.11426	2.26	0.093
Residual	24	1.21425	0.05059		
<b>Total</b>	<b>53</b>	<b>9.25696</b>			

**Tables of means**

Grand mean: 10.466

<b>CV</b>	<b>SST015</b>	<b>SST57</b>	<b>SST88</b>				
	10.768	10.622	10.009				
<b>RW</b>	<b>250</b>	<b>300</b>					
	10.417	10.516					
<b>PD</b>	<b>150</b>	<b>200</b>	<b>250</b>				
	10.388	10.500	10.511				
<b>CV</b>	<b>RW</b>	<b>250</b>	<b>300</b>				
<b>SST015</b>		10.794	10.741				
<b>SST57</b>		10.466	10.779				
<b>SST88</b>		9.991	10.027				
<b>CV</b>	<b>PD</b>	<b>150</b>	<b>200</b>	<b>250</b>			
<b>SST015</b>		10.548	10.924	10.831			
<b>SST57</b>		10.588	10.600	10.679			
<b>SST88</b>		10.029	9.975	10.024			
<b>RW</b>	<b>PD</b>	<b>150</b>	<b>200</b>	<b>250</b>			
<b>250</b>		10.377	10.458	10.416			
<b>300</b>		10.400	10.541	10.606			
<b>CV</b>	<b>RW</b>	<b>250</b>	<b>200</b>	<b>250</b>	<b>300</b>	<b>200</b>	<b>250</b>
<b>SST015</b>	<b>PD</b>	10.503	11.042	10.838	10.594	10.806	10.824
<b>SST57</b>		10.463	10.534	10.401	10.713	10.667	10.957
<b>SST88</b>		10.166	9.798	10.009	9.892	10.151	10.038

**Analysis of variance**

Source of variation	d.f.	s.s.	m.s.	v.r.	F pr.
<b>REP stratum</b>	2	1.0456	0.5228	0.05	
<b>REP.WPLOT stratum</b>					
CULT	2	9.8311	4.9156	0.46	0.661
Residual	4	42.7218	10.6804	29.82	
<b>REP.WPLOT.SPLOT stratum</b>					
RW	1	0.3684	0.3684	1.03	0.350
CULT.RW	2	0.1430	0.0715	0.20	0.824
Residual	6	2.1491	0.3582	1.11	
<b>REP.WPLOT.SPLOT.SSPLOT stratum</b>					
PD	2	0.5908	0.2954	0.91	0.415
CULT.PD	4	1.0932	0.2733	0.84	0.511
RW.PD	2	0.2222	0.1111	0.34	0.713
CULT.RW.PD	4	1.5167	0.3792	1.17	0.349
Residual	24	7.7755	0.3240		
<b>Total</b>	53	67.4574			

**Tables of means**

Grand mean: 77.537

<b>CULT</b>	<b>SST57</b>	<b>SST88</b>	<b>SST94</b>				
	77.559	78.048	77.003				
<b>RW</b>	<b>250</b>	<b>300</b>					
	77.619	77.454					
<b>PD</b>	<b>150</b>	<b>200</b>	<b>250</b>				
	77.393	77.640	77.577				
<b>CULT</b>	<b>RW</b>	<b>250</b>	<b>300</b>				
<b>SST57</b>		77.713	77.404				
<b>SST88</b>		78.104	77.991				
<b>SST94</b>		77.040	76.967				
<b>CULT</b>	<b>PD</b>	<b>150</b>	<b>200</b>	<b>250</b>			
<b>SST57</b>		77.583	77.777	77.317			
<b>SST88</b>		77.817	78.110	78.217			
<b>SST94</b>		76.780	77.033	77.197			
<b>RW</b>	<b>PD</b>	<b>150</b>	<b>200</b>	<b>250</b>			
<b>250</b>		77.564	77.696	77.598			
<b>300</b>		77.222	77.584	77.556			
<b>CULT</b>	<b>RW</b>	<b>250</b>	<b>200</b>	<b>250</b>	<b>300</b>	<b>200</b>	<b>250</b>
<b>SST57</b>	<b>PD</b>	77.740	77.740	77.660	77.427	77.813	76.973
<b>SST88</b>		78.193	78.113	78.007	77.440	78.107	78.427
<b>SST94</b>		76.760	77.233	77.127	76.800	76.833	77.267

**Analysis of variance**

Source of variation	d.f.	s.s.	m.s.	v.r.	F pr.
<b>Rep stratum</b>	2	79.029	39.514	3.03	
<b>Rep.CV stratum</b>					
CV	1	172.923	172.923	13.28	0.068
Residual	2	26.048	13.024	11.48	
<b>Rep.CV.RW stratum</b>					
RW	1	2.924	2.924	2.58	0.184
CV.RW	1	1.823	1.823	1.61	0.274
Residual	4	4.538	1.134	0.41	
<b>Rep.CV.RW.PD stratum</b>					
PD	2	34.747	17.374	6.22	<b>0.010*</b>
CV.PD	2	4.082	2.041	0.73	0.497
RW.PD	2	2.950	1.475	0.53	0.600
CV.RW.PD	2	2.902	1.451	0.52	0.604
Residual	16	44.676	2.792		
<b>Total</b>	35	376.641			

**Tables of means**

Grand mean: 75.90

<b>CV</b>	<b>SST 88</b>	<b>SST 94</b>					
	78.10	73.71					
<b>RW</b>	<b>250</b>	<b>300</b>					
	75.62	76.19					
<b>PD</b>	<b>150</b>	<b>200</b>	<b>250</b>				
	74.67	75.97	77.07				
<b>CV</b>	<b>RW</b>	<b>250</b>	<b>300</b>				
<b>SST 88</b>		78.04	78.16				
<b>SST 94</b>		73.20	74.22				
<b>CV</b>	<b>PD</b>	<b>150</b>	<b>200</b>	<b>250</b>			
<b>SST 88</b>		76.43	78.56	79.30			
<b>SST 94</b>		72.91	73.39	74.84			
<b>RW</b>	<b>PD</b>	<b>150</b>	<b>200</b>	<b>250</b>			
<b>250</b>		74.61	75.29	76.96			
		74.72	76.66	77.18			
<b>CV</b>	<b>RW</b>	<b>250</b>	<b>200</b>	<b>250</b>	<b>300</b>	<b>200</b>	<b>250</b>
<b>SST 88</b>	<b>PD</b>	76.99	77.83	79.28	75.86	79.28	79.33
<b>SST 94</b>		72.23	72.74	74.63	73.58	74.05	75.04

Analysis of variance

Source of variation	d.f.	s.s.	m.s.	v.r.	F pr.
REP stratum	2	0.5748	0.2874	1.48	
REP.CV stratum					
CV	2	113.6059	56.8030	292.69	<.001**
Residual	4	0.7763	0.1941	1.87	
REP.CV.RW stratum					
RW	1	1.1267	1.1267	10.86	0.016*
CV.RW	2	1.0844	0.5422	5.23	0.048*
Residual	6	0.6222	0.1037	0.32	
REP.CV.RW.PD stratum					
PD	2	0.7570	0.3785	1.18	0.325
CV.PD	4	2.7674	0.6919	2.15	0.105
RW.PD	2	1.2933	0.6467	2.01	0.155
CV.RW.PD	4	1.3156	0.3289	1.02	0.415
Residual	24	7.7067	0.3211		
<b>Total</b>	<b>53</b>	<b>131.6304</b>			

Tables of means

Grand mean: 76.441

<b>CV</b>	<b>SST015</b>	<b>SST57</b>	<b>SST88</b>				
	75.767	75.100	78.456				
<b>RW</b>	<b>250</b>	<b>300</b>					
	76.296	76.585					
<b>PD</b>	<b>150</b>	<b>200</b>	<b>250</b>				
	76.556	76.489	76.278				
<b>CV</b>	<b>RW</b>	<b>250</b>	<b>300</b>				
<b>SST015</b>		75.711	75.822				
<b>SST57</b>		74.756	75.444				
<b>SST88</b>		78.422	78.489				
<b>CV</b>	<b>PD</b>	<b>150</b>	<b>200</b>	<b>250</b>			
<b>SST015</b>		76.100	75.500	75.700			
<b>SST57</b>		74.900	75.567	74.833			
<b>SST88</b>		78.667	78.400	78.300			
<b>RW</b>	<b>PD</b>	<b>150</b>	<b>200</b>	<b>250</b>			
<b>250</b>		76.622	76.289	75.978			
<b>300</b>		76.489	76.689	76.578			
<b>CV</b>	<b>RW</b>	<b>250</b>	<b>200</b>		<b>250</b>	<b>300</b>	<b>200</b>
<b>SST015</b>	<b>PD</b>	<b>150</b>	<b>200</b>	<b>250</b>	<b>150</b>	<b>200</b>	<b>250</b>
		76.133	75.400	75.600	76.067	75.600	75.800
<b>SST57</b>		75.067	75.000	74.200	74.733	76.133	75.467
<b>SST88</b>		78.667	78.467	78.133	78.667	78.333	78.467

**CVxRWxPD Caledon 2004  
Grain Yield (ton ha<sup>-1</sup>)**

**C-15**

**Analysis of variance**

Source of variation	d.f.(mv)	s.s.	m.s.	v.r.	F pr.
<b>REP stratum</b>	2	3.0116	1.5058	22.14	
<b>REP.WPLOT stratum</b>					
CULT	2	11.4920	5.7460	84.50	<b>&lt;.001**</b>
Residual	4	0.2720	0.0680	2.68	
<b>REP.WPLOT.SPLOT stratum</b>					
RW	1	0.5797	0.5797	22.89	<b>0.003*</b>
CULT.RW	2	0.0894	0.0447	1.76	0.250
Residual	6	0.1520	0.0253	0.21	
<b>REP.WPLOT.SPLOT.SSPLOT stratum</b>					
PD	2	0.3571	0.1785	1.49	0.246
CULT.PD	4	0.5241	0.1310	1.09	0.383
RW.PD	2	0.2641	0.1321	1.10	0.349
CULT.RW.PD	4	0.4517	0.1129	0.94	0.457
Residual	23(1)	2.7548	0.1198		
<b>Total</b>	52(1)	19.8932			

**Tables of means**

**Grand mean: 2.618**

<b>CULT</b>	<b>SST57</b>	<b>SST88</b>	<b>SST94</b>				
	2.434	3.252	2.168				
<b>RW</b>	<b>250</b>	<b>300</b>					
	2.722	2.514					
<b>PD</b>	<b>100</b>	<b>175</b>	<b>250</b>				
	2.709	2.633	2.512				
<b>CULT</b>	<b>RW</b>	<b>250</b>	<b>300</b>				
<b>SST57</b>		2.549	2.319				
<b>SST88</b>		3.301	3.203				
<b>SST94</b>		2.315	2.021				
<b>CULT</b>	<b>PD</b>	<b>100</b>	<b>175</b>	<b>250</b>			
<b>SST57</b>		2.535	2.498	2.268			
<b>SST88</b>		3.192	3.256	3.309			
<b>SST94</b>		2.400	2.147	1.958			
<b>RW</b>	<b>PD</b>	<b>100</b>	<b>175</b>	<b>250</b>			
<b>250</b>		2.726	2.822	2.616			
<b>300</b>		2.692	2.445	2.407			
<b>CULT</b>	<b>RW</b>	<b>250</b>	<b>175</b>	<b>250</b>	<b>300</b>	<b>175</b>	<b>250</b>
<b>SST57</b>	<b>PD</b>	<b>100</b>	<b>175</b>	<b>250</b>	<b>100</b>	<b>2.321</b>	<b>2.219</b>
		2.654	2.674	2.318	2.417		
<b>SST88</b>		3.069	3.535	3.300	3.315	2.977	3.317
<b>SST94</b>		2.457	2.258	2.231	2.342	2.036	1.685

**Analysis of variance**

Source of variation	d.f.	s.s.	m.s.	v.r.	F pr.
<b>Rep stratum</b>	2	1.37587	0.68794	1.31	
<b>Rep.Cul stratum</b>					
Cul	2	3.21071	1.60535	3.05	0.157
Residual	4	2.10581	0.52645	3.65	
<b>Rep.Cul.RW stratum</b>					
RW	1	0.00017	0.00017	0.00	0.974
Cul.RW	2	0.10916	0.05458	0.38	0.700
Residual	6	0.86547	0.14424	1.63	
<b>Rep.Cul.RW.PD stratum</b>					
PD	2	1.39917	0.69958	7.92	<b>0.002*</b>
Cul.PD	4	0.36345	0.09086	1.03	0.413
RW.PD	2	0.05053	0.02526	0.29	0.754
Cul.RW.PD	4	0.51495	0.12874	1.46	0.246
Residual	24	2.11971	0.08832		
Total	53	12.11498			

**Tables of means**

Grand mean: 3.648

<b>Cul</b>	<b>SST 57</b>	<b>SST 88</b>	<b>SST 94</b>				
	3.338	3.934	3.672				
<b>RW</b>	<b>250</b>	<b>300</b>					
	3.646	3.650					
<b>PD</b>	<b>100</b>	<b>175</b>	<b>250</b>				
	3.865	3.599	3.480				
<b>Cul</b>	<b>RW</b>	<b>250</b>	<b>300</b>				
<b>SST 57</b>		3.322	3.354				
<b>SST 88</b>		3.886	3.982				
<b>SST 94</b>		3.731	3.613				
<b>Cul</b>	<b>PD</b>	<b>100</b>	<b>175</b>	<b>250</b>			
<b>SST 57</b>		3.640	3.270	3.104			
<b>SST 88</b>		3.992	3.977	3.832			
<b>SST 94</b>		3.962	3.550	3.503			
<b>RW</b>	<b>PD</b>	<b>100</b>	<b>175</b>	<b>250</b>			
<b>250</b>		3.889	3.614	3.435			
<b>300</b>		3.841	3.584	3.525			
<b>Cul</b>	<b>RW</b>	<b>250</b>	<b>175</b>	<b>250</b>	<b>300</b>	<b>175</b>	<b>250</b>
<b>SST 57</b>	<b>PD</b>	<b>100</b>	<b>175</b>	<b>250</b>	<b>100</b>	<b>3.232</b>	<b>3.278</b>
		3.726	3.308	2.931	3.554		
<b>SST 88</b>		3.951	3.801	3.905	4.033	4.153	3.759
<b>SST 94</b>		3.990	3.734	3.470	3.934	3.367	3.537

**Analysis of variance**

Source of variation	d.f.(mv)	s.s.	m.s.	v.r.	F pr.
<b>REP stratum</b>	2	0.6354	0.3177	1.02	
<b>REP.CV stratum</b>					
CV	2	0.8950	0.4475	1.44	0.338
Residual	4	1.2441	0.3110	1.71	
<b>REP.CV.RW stratum</b>					
RW	1	1.4127	1.4127	7.78	<b>0.032*</b>
CV.RW	2	0.0930	0.0465	0.26	0.782
Residual	6	1.0888	0.1815	0.71	
<b>REP.CV.RW.PD stratum</b>					
PD	2	1.1126	0.5563	2.19	0.135
CV.PD	4	1.6719	0.4180	1.65	0.197
RW.PD	2	1.4107	0.7054	2.78	0.083
CV.RW.PD	4	0.9917	0.2479	0.98	0.440
Residual	23(1)	5.8396	0.2539		
<b>Total</b>	52(1)	15.1468			

**Tables of means**

Grand mean: 4.368

<b>CV</b>	<b>SST015</b>	<b>SST57</b>	<b>SST88</b>				
	4.357	4.216	4.531				
<b>RW</b>	<b>250</b>	<b>300</b>					
	4.530	4.206					
<b>PD</b>	<b>100</b>	<b>175</b>	<b>250</b>				
	4.169	4.504	4.431				
<b>CV</b>	<b>RW</b>	<b>250</b>	<b>300</b>				
<b>SST015</b>		4.522	4.193				
<b>SST57</b>		4.427	4.005				
<b>SST88</b>		4.640	4.421				
<b>CV</b>	<b>PD</b>	<b>100</b>	<b>175</b>	<b>250</b>			
<b>SST015</b>		3.916	4.432	4.724			
<b>SST57</b>		4.050	4.502	4.095			
<b>SST88</b>		4.542	4.577	4.473			
<b>RW</b>	<b>PD</b>	<b>100</b>	<b>175</b>	<b>250</b>			
<b>250</b>		4.214	4.894	4.481			
<b>300</b>		4.125	4.113	4.380			
<b>CV</b>	<b>RW</b>	<b>250</b>	<b>175</b>	<b>250</b>	<b>300</b>	<b>175</b>	<b>250</b>
<b>SST015</b>	<b>PD</b>	<b>100</b>	<b>175</b>	<b>250</b>	<b>100</b>	<b>3.860</b>	<b>4.680</b>
		3.793	5.003	4.768	4.038		
<b>SST57</b>		4.072	4.923	4.286	4.029	4.081	3.904
<b>SST88</b>		4.776	4.756	4.390	4.308	4.399	4.556



**Analysis of variance**

Source of variation	d.f.(m.v.)	s.s.	m.s.	v.r.	F pr.
<b>REP stratum</b>	2	9.3995	4.6997	20.78	
<b>REP.WPLOT stratum</b>					
CULT	2	0.2981	0.1490	0.66	0.566
Residual	4	0.9045	0.2261	2.93	
<b>REP.WPLOT.SPLOT stratum</b>					
RW	1	0.0213	0.0213	0.28	0.618
CULT.RW	2	0.0467	0.0234	0.30	0.749
Residual	6	0.4631	0.0772	0.46	
<b>REP.WPLOT.SPLOT.SSPLOT stratum</b>					
PD	2	0.7959	0.3979	2.38	0.114
CULT.PD	4	0.3044	0.0761	0.46	0.767
RW.PD	2	0.5512	0.2756	1.65	0.214
CULT.RW.PD	4	0.5209	0.1302	0.78	0.549
Residual	23(1)	3.8375	0.1668		
<b>Total</b>	52(1)	16.7776			

**Tables of means**

Grand mean: 10.399

<b>CULT</b>	<b>SST57</b>	<b>SST88</b>	<b>SST94</b>				
	10.343	10.350	10.504				
<b>RW</b>	<b>250</b>	<b>300</b>					
	10.379	10.419					
<b>PD</b>	<b>100</b>	<b>175</b>	<b>250</b>				
	10.546	10.249	10.402				
<b>CULT</b>	<b>RW</b>	<b>250</b>	<b>300</b>				
<b>SST57</b>		10.322	10.364				
<b>SST88</b>		10.367	10.333				
<b>SST94</b>		10.449	10.560				
<b>CULT</b>	<b>PD</b>	<b>100</b>	<b>175</b>	<b>250</b>			
<b>SST57</b>		10.398	10.337	10.295			
<b>SST88</b>		10.569	10.099	10.382			
<b>SST94</b>		10.672	10.311	10.530			
<b>RW</b>	<b>PD</b>	<b>100</b>	<b>175</b>	<b>250</b>			
<b>250</b>		10.620	10.275	10.242			
<b>300</b>		10.472	10.222	10.562			
<b>CULT</b>	<b>RW</b>	<b>250</b>	<b>175</b>	<b>250</b>	<b>300</b>	<b>175</b>	<b>250</b>
<b>SST57</b>	<b>PD</b>	10.394	10.405	10.168	10.402	10.269	10.421
<b>SST88</b>		10.764	10.247	10.088	10.373	9.952	10.675
<b>SST94</b>		10.702	10.174	10.469	10.642	10.447	10.590

**Analysis of variance**

Source of variation	d.f.	s.s.	m.s.	v.r.	F pr.
<b>Rep stratum</b>	2	0.18834	0.09417	0.12	
<b>Rep.Cul stratum</b>					
Cul	2	6.93350	3.46675	4.43	0.097
Residual	4	3.13287	0.78322	1.98	
<b>Rep.Cul.RW stratum</b>					
RW	1	0.00448	0.00448	0.01	0.919
Cul.RW	2	1.02866	0.51433	1.30	0.340
Residual	6	2.37582	0.39597	4.24	
<b>Rep.Cul.RW.PD stratum</b>					
PD	2	0.08872	0.04436	0.48	0.627
Cul.PD	4	0.39824	0.09956	1.07	0.394
RW.PD	2	0.04391	0.02196	0.24	0.792
Cul.RW.PD	4	0.28271	0.07068	0.76	0.563
Residual	24	2.23954	0.09331		
Total	53	16.71680			

**Tables of means**

Grand mean: 8.210

<b>Cul</b>	<b>SST 57</b> 7.856	<b>SST 88</b> 8.701	<b>SST 94</b> 8.072				
<b>RW</b>	<b>250</b> 8.201	<b>300</b> 8.219					
<b>PD</b>	<b>100</b> 8.154	<b>175</b> 8.248	<b>250</b> 8.228				
<b>Cul</b>	<b>RW</b>	<b>250</b>	<b>300</b>				
<b>SST 57</b>		7.832	7.880				
<b>SST 88</b>		8.531	8.871				
<b>SST 94</b>		8.239	7.905				
<b>Cul</b>	<b>PD</b>	<b>100</b>	<b>175</b>	<b>250</b>			
<b>SST 57</b>		7.678	7.886	8.004			
<b>SST 88</b>		8.727	8.799	8.578			
<b>SST 94</b>		8.056	8.059	8.101			
<b>RW</b>	<b>PD</b>	<b>100</b>	<b>175</b>	<b>250</b>			
<b>250</b>		8.108	8.271	8.223			
<b>300</b>		8.200	8.225	8.232			
<b>Cul</b>	<b>RW</b>	<b>250</b>	<b>175</b>	<b>250</b>	<b>300</b>	<b>175</b>	<b>250</b>
<b>SST 57</b>	<b>PD</b>	<b>100</b>	<b>175</b>	<b>250</b>	<b>100</b>	<b>175</b>	<b>250</b>
		7.628	7.916	7.953	7.729	7.857	8.056
<b>SST 88</b>		8.495	8.764	8.333	8.958	8.833	8.822
<b>SST 94</b>		8.199	8.133	8.384	7.913	7.984	7.818

**Analysis of variance**

Source of variation	d.f.	s.s.	m.s.	v.r.	F pr.
<b>REP stratum</b>	2	0.2820	0.1410	2.01	
<b>REP.CV stratum</b>					
CV	2	1.5302	0.7651	10.93	<b>0.024*</b>
Residual	4	0.2801	0.0700	2.74	
<b>REP.CV.RW stratum</b>					
RW	1	0.7767	0.7767	30.43	<b>0.001*</b>
CV.RW	2	0.2513	0.1257	4.92	0.054
Residual	6	0.1531	0.0255	0.18	
<b>REP.CV.RW.PD stratum</b>					
PD	2	0.4947	0.2474	1.75	0.196
CV.PD	4	0.3588	0.0897	0.63	0.644
RW.PD	2	0.0527	0.0264	0.19	0.831
CV.RW.PD	4	0.7727	0.1932	1.36	0.276
Residual	24	3.4012	0.1417		
<b>Total</b>	53	8.3536			

**Tables of means**

Grand mean: 10.775

<b>CV</b>	<b>SST015</b>	<b>SST57</b>	<b>SST88</b>				
	10.840	10.941	10.544				
<b>RW</b>	<b>250</b>	<b>300</b>					
	10.655	10.895					
<b>PD</b>	<b>100</b>	<b>175</b>	<b>250</b>				
	10.644	10.812	10.869				
<b>CV</b>	<b>RW</b>	<b>250</b>	<b>300</b>				
<b>SST015</b>		10.665	11.014				
<b>SST57</b>		10.918	10.965				
<b>SST88</b>		10.383	10.706				
<b>CV</b>	<b>SD</b>	<b>100</b>	<b>175</b>	<b>250</b>			
<b>SST015</b>		10.589	10.979	10.951			
<b>SST57</b>		10.854	10.862	11.108			
<b>SST88</b>		10.488	10.597	10.548			
<b>RW</b>	<b>SD</b>	<b>100</b>	<b>175</b>	<b>250</b>			
<b>250</b>		10.497	10.675	10.793			
<b>300</b>		10.790	10.950	10.945			
<b>CV</b>	<b>RW</b>	<b>250</b>	<b>175</b>	<b>250</b>	<b>300</b>	<b>175</b>	<b>250</b>
<b>SST015</b>	<b>SD</b>	<b>100</b>	<b>175</b>	<b>250</b>	<b>100</b>	<b>10.992</b>	<b>11.148</b>
		10.277	10.966	10.753	10.902		
<b>SST57</b>		10.793	10.661	11.298	10.914	11.062	10.919
<b>SST88</b>		10.421	10.399	10.328	10.555	10.795	10.768

Analysis of variance

Source of variation	d.f.(m.v.)	s.s.	m.s.	v.r.	F pr.
REP stratum	2	0.0940	0.0470	0.18	
REP.WPLOT stratum					
CULT	2	51.8055	25.9027	100.38	<.001**
Residual	4	1.0322	0.2581	0.82	
REP.WPLOT.SPLOT stratum					
RW	1	0.0105	0.0105	0.03	0.861
CULT.RW	2	0.7901	0.3951	1.26	0.349
Residual	6	1.8775	0.3129	0.50	
REP.WPLOT.SPLOT.SSPLOT stratum					
PD	2	0.4994	0.2497	0.40	0.677
CULT.PD	4	1.9952	0.4988	0.79	0.541
RW.PD	2	0.8835	0.4418	0.70	0.505
CULT.RW.PD	4	3.6899	0.9225	1.47	0.244
Residual	23(1)	14.4544	0.6285		
<b>Total</b>	<b>52(1)</b>	<b>76.8047</b>			

Tables of means

Grand mean: 78.93

<b>CULT</b>	<b>SST57</b>	<b>SST88</b>	<b>SST94</b>				
	78.36	80.31	78.13				
<b>RW</b>	<b>250</b>	<b>300</b>					
	78.92	78.95					
<b>PD</b>	<b>100</b>	<b>175</b>	<b>250</b>				
	78.81	78.94	79.05				
<b>CULT</b>	<b>RW</b>	<b>250</b>	<b>300</b>				
<b>SST57</b>		78.44	78.27				
<b>SST88</b>		80.13	80.50				
<b>SST94</b>		78.19	78.07				
<b>CULT</b>	<b>PD</b>	<b>100</b>	<b>175</b>	<b>250</b>			
<b>SST57</b>		78.21	78.24	78.63			
<b>SST88</b>		80.03	80.68	80.23			
<b>SST94</b>		78.20	77.91	78.29			
<b>RW</b>	<b>PD</b>	<b>100</b>	<b>175</b>	<b>250</b>			
<b>250</b>		78.63	79.06	79.07			
<b>300</b>		79.00	78.82	79.03			
<b>CULT</b>	<b>RW</b>	<b>250</b>	<b>175</b>	<b>250</b>	<b>300</b>	<b>175</b>	<b>250</b>
<b>SST57</b>	<b>PD</b>	<b>100</b>	<b>175</b>	<b>250</b>	<b>100</b>	<b>78.25</b>	<b>78.47</b>
		78.32	78.22	78.78	78.09		
<b>SST88</b>		79.31	81.14	79.94	80.75	80.23	80.52
<b>SST94</b>		78.26	77.83	78.49	78.15	77.98	78.09

**Analysis of variance**

Source of variation	d.f.	s.s.	m.s.	v.r.	F pr.
<b>Rep stratum</b>	2	5.8380	2.9190	4.47	
<b>Rep.Cul stratum</b>					
Cul	2	8.3070	4.1535	6.36	0.057
Residual	4	2.6127	0.6532	2.50	
<b>Rep.Cul.RW stratum</b>					
RW	1	0.0046	0.0046	0.02	0.899
Cul.RW	2	1.1462	0.5731	2.19	0.193
Residual	6	1.5696	0.2616	0.97	
<b>Rep.Cul.RW.PD stratum</b>					
PD	2	0.8280	0.4140	1.53	0.237
Cul.PD	4	0.8611	0.2153	0.80	0.540
RW.PD	2	0.8569	0.4285	1.58	0.226
Cul.RW.PD	4	0.1970	0.0492	0.18	0.945
Residual	24	6.4935	0.2706		
<b>Total</b>	53	28.7147			

**Tables of means**

Grand mean: 78.126

<b>Cul</b>	<b>SST 57</b> 77.862	<b>SST 88</b> 78.680	<b>SST 94</b> 77.834				
<b>RW</b>	<b>250</b> 78.135	<b>300</b> 78.116					
<b>PD</b>	<b>100</b> 78.266	<b>175</b> 78.147	<b>250</b> 77.964				
<b>Cul</b>	<b>RW</b>	<b>250</b> 77.820	<b>300</b> 77.904				
<b>SST 57</b>		78.542	78.818				
<b>SST 88</b>		78.042	77.627				
<b>SST 94</b>							
<b>Cul</b>	<b>SD</b>	<b>100</b> 77.827	<b>175</b> 78.080	<b>250</b> 77.680			
<b>SST 57</b>		78.937	78.683	78.420			
<b>SST 88</b>		78.033	77.677	77.793			
<b>SST 94</b>							
<b>RW</b>	<b>SD</b>	<b>100</b> 78.440	<b>175</b> 78.131	<b>250</b> 77.833			
<b>250</b>		78.091	78.162	78.096			
<b>300</b>							
<b>Cul</b>	<b>RW</b>	<b>250</b> 77.913	<b>175</b> 77.980	<b>250</b> 77.567	<b>300</b> 77.740	<b>175</b> 78.180	<b>250</b> 77.793
<b>SST 57</b>	<b>SD</b>	78.960	78.620	78.047	78.913	78.747	78.793
<b>SST 88</b>		78.447	77.793	77.887	77.620	77.560	77.700
<b>SST 94</b>							

Analysis of variance

Source of variation	d.f.	s.s.	m.s.	v.r.	F pr.
REP stratum	2	9.9215	4.9607	1.44	
REP.CV stratum					
CV	2	29.3704	14.6852	4.27	0.102
Residual	4	13.7630	3.4407	17.53	
REP.CV.RW stratum					
RW	1	0.1896	0.1896	0.97	0.364
CV.RW	2	0.7126	0.3563	1.82	0.242
Residual	6	1.1778	0.1963	0.43	
REP.CV.RW.PD stratum					
PD	2	1.3881	0.6941	1.50	0.243
CV.PD	4	2.3763	0.5941	1.29	0.303
RW.PD	2	0.6326	0.3163	0.68	0.514
CV.RW.PD	4	0.4919	0.1230	0.27	0.897
Residual	24	11.0844	0.4619		
<b>Total</b>	<b>53</b>	<b>71.1081</b>			

Tables of means

Grand mean: 79.215

<b>CV</b>	<b>SST015</b>	<b>SST57</b>	<b>SST88</b>				
	78.900	78.511	80.233				
<b>RW</b>	<b>250</b>	<b>300</b>					
	79.156	79.274					
<b>PD</b>	<b>100</b>	<b>175</b>	<b>250</b>				
	79.344	79.311	78.989				
<b>CV</b>	<b>RW</b>	<b>250</b>	<b>300</b>				
<b>SST015</b>		78.689	79.111				
<b>SST57</b>		78.578	78.444				
<b>SST88</b>		80.200	80.267				
<b>CV</b>	<b>PD</b>	<b>100</b>	<b>175</b>	<b>250</b>			
<b>SST015</b>		78.967	78.833	78.900			
<b>SST57</b>		78.967	78.600	77.967			
<b>SST88</b>		80.100	80.500	80.100			
<b>RW</b>	<b>PD</b>	<b>100</b>	<b>175</b>	<b>250</b>			
<b>250</b>		79.178	79.400	78.889			
<b>300</b>		79.511	79.222	79.089			
<b>CV</b>	<b>RW</b>	<b>250</b>	<b>175</b>		<b>250</b>		
<b>SST015</b>	<b>PD</b>	<b>100</b>	<b>175</b>	<b>250</b>	<b>300</b>	<b>175</b>	<b>250</b>
		78.533	78.867	78.667	79.400	78.800	79.133
<b>SST57</b>		79.000	78.867	77.867	78.933	78.333	78.067
<b>SST88</b>		80.000	80.467	80.133	80.200	80.533	80.067

**CVxRWxPD Moorreesburg 2005**  
Heads m<sup>-2</sup>

D-1

Analysis of variance Source of variation	d.f.	s.s.	m.s.	v.r.	F pr.
Rep stratum	2	408 .	204 .	2.55	
<b>Rep.Cul stratum</b>					
Cul	1	20417	20417	254.68	<b>0.004*</b>
Residual	2	160 .	80	0.14	
<b>Rep.Cul.RW stratum</b>					
RW	2	48583	24292	41.89	<b>&lt;.001**</b>
Cul.RW	2	1262	631	1.09	0.382
Residual	8	4640	580	0.33	
<b>Rep.Cul.RW.PD stratum</b>					
PD	2	8438	4219	2.38	0.114
Cul.PD	2	1753	877	0.50	0.615
RW.PD	4	1868	467	0.26	0.898
Cul.RW.PD	4	3532	883	0.50	0.737
Residual	24	42468	1769		
<b>Total</b>	<b>53</b>	<b>133529</b>			

**Tables of means**

Grand mean: 283.6

<b>Cul</b>	<b>SST 88</b>	<b>SST 94</b>			
	264.1	303.0			
<b>RW</b>	<b>250</b>	<b>300</b>	<b>350</b>		
	311.3	297.5	241.9		
<b>PD</b>	<b>100</b>	<b>175</b>	<b>250</b>		
	269.3	281.7	299.7		
<b>Cul</b>	<b>RW</b>	<b>250</b>	<b>300</b>	<b>350</b>	
<b>SST 88</b>		297.9	277.8	216.7	
<b>SST 94</b>		324.7	317.2	267.1	
<b>Cul</b>	<b>PD</b>	<b>100</b>	<b>175</b>	<b>250</b>	
<b>SST 88</b>		257.7	256.7	278.0	
<b>SST 94</b>		280.9	306.7	321.4	
<b>RW</b>	<b>PD</b>	<b>100</b>	<b>175</b>	<b>250</b>	
<b>250</b>		302.8	308.3	322.7	
<b>300</b>		274.0	294.2	324.3	
<b>350</b>		231.0	242.5	252.2	
<b>Cul</b>	<b>RW</b>	<b>PD</b>	<b>100</b>	<b>175</b>	<b>250</b>
<b>SST 88</b>	<b>250</b>		290.0	288.0	315.7
	<b>300</b>		255.3	270.7	307.3
	<b>350</b>		227.7	211.3	211.0
<b>SST 94</b>	<b>250</b>		315.7	328.7	329.7
	<b>300</b>		292.7	317.7	341.3
	<b>350</b>		234.3	273.7	293.3

**CVxRWxPD Moorreesburg 2005  
Heads plant<sup>-1</sup>**

**D-2**

**Analysis of variance**

Source of variation	d.f.(mv)	s.s.	m.s.	v.r.	F pr.
<b>Rep stratum</b>	2	0.03420	0.01710	0.30	
<b>Rep.Cul stratum</b>					
Cul	1	0.85024	0.85024	14.97	0.061
Residual	2	0.11356	0.05678	0.81	
<b>Rep.Cul.RW stratum</b>					
RW	2	1.09966	0.54983	7.80	<b>0.013*</b>
Cul.RW	2	0.09115	0.04557	0.65	0.549
Residual	8	0.56365	0.07046	0.74	
<b>Rep.Cul.RW.PD stratum</b>					
PD	2	14.50469	7.25235	76.60	<b>&lt;.001**</b>
Cul.PD	2	0.06662	0.03331	0.35	0.707
RW.PD	4	0.51277	0.12819	1.35	0.280
Cul.RW.PD	4	0.39004	0.09751	1.03	0.413
Residual	23(1)	2.17750	0.09467		
<b>Total</b>	52(1)	20.34792			

**Tables of means**

**Grand mean: 1.711**

<b>Cul</b>	<b>SST 88</b>	<b>SST 94</b>			
	1.585	1.836			
<b>RW</b>	<b>250</b>	<b>300</b>	<b>350</b>		
	1.828	1.794	1.510		
<b>PD</b>	<b>100</b>	<b>175</b>	<b>250</b>		
	2.428	1.483	1.221		
<b>Cul</b>	<b>RW</b>	<b>250</b>	<b>300</b>	<b>350</b>	
<b>SST 88</b>		1.756	1.622	1.378	
<b>SST 94</b>		1.900	1.967	1.642	
<b>Cul</b>	<b>PD</b>	<b>100</b>	<b>175</b>	<b>250</b>	
<b>SST 88</b>		2.311	1.311	1.133	
<b>SST 94</b>		2.544	1.656	1.308	
<b>RW</b>	<b>PD</b>	<b>100</b>	<b>175</b>	<b>250</b>	
<b>250</b>		2.650	1.617	1.217	
<b>300</b>		2.583	1.500	1.300	
<b>350</b>		2.050	1.333	1.146	
<b>Cul</b>	<b>RW</b>	<b>PD</b>	<b>100</b>	<b>175</b>	<b>250</b>
<b>SST 88</b>	<b>250</b>		2.500	1.500	1.267
	<b>300</b>		2.367	1.267	1.233
	<b>350</b>		2.067	1.167	0.900
<b>SST 94</b>	<b>250</b>		2.800	1.733	1.167
	<b>300</b>		2.800	1.733	1.367
	<b>350</b>		2.033	1.500	1.392



**CVxRWxPD Moorreesburg 2005**  
**Kernels head<sup>-2</sup>**

**D-3**

<b>Analysis of variance</b>					
<b>Source of variation</b>	<b>d.f.</b>	<b>s.s.</b>	<b>m.s.</b>	<b>v.r.</b>	<b>F pr.</b>
<b>Rep stratum</b>	2	96.02	48.01	7.72	
<b>Rep.Cul stratum</b>					
Cul	1	938.41	938.41	150.84	<b>0.007*</b>
Residual	2	12.44	6.22	0.36	
<b>Rep.Cul.RW stratum</b>					
RW	2	132.20	66.10	3.87	0.067
Cul.RW	2	10.07	5.03	0.29	0.753
Residual	8	136.69	17.09	0.53	
<b>Rep.Cul.RW.PD stratum</b>					
PD	2	71.97	35.99	1.11	0.344
Cul.PD	2	12.46	6.23	0.19	0.826
RW.PD	4	36.75	9.19	0.28	0.885
Cul.RW.PD	4	83.86	20.96	0.65	0.633
Residual	24	774.84	32.28		
<b>Total</b>	<b>53</b>	<b>2305.72</b>			

**Tables of means**

**Grand mean: 28.02**

<b>Cul</b>	<b>SST 88</b>	<b>SST 94</b>			
	23.85	32.18			
<b>RW</b>	<b>250</b>	<b>300</b>	<b>350</b>		
	26.93	26.89	30.23		
<b>PD</b>	<b>100</b>	<b>175</b>	<b>250</b>		
	26.72	29.52	27.80		
<b>Cul</b>	<b>RW</b>	<b>250</b>	<b>300</b>	<b>350</b>	
<b>SST 88</b>		22.22	23.23	26.08	
<b>SST 94</b>		31.64	30.54	34.37	
<b>Cul</b>	<b>PD</b>	<b>100</b>	<b>175</b>	<b>250</b>	
<b>SST 88</b>		22.78	24.69	24.07	
<b>SST 94</b>		30.66	34.36	31.53	
<b>RW</b>	<b>PD</b>	<b>100</b>	<b>175</b>	<b>250</b>	
<b>250</b>		24.95	27.68	28.16	
<b>300</b>		26.40	28.99	25.28	
<b>350</b>		28.81	31.90	29.97	
<b>Cul</b>	<b>RW</b>	<b>PD</b>	<b>100</b>	<b>175</b>	<b>250</b>
<b>SST 88</b>	<b>250</b>		20.82	23.22	22.62
	<b>300</b>		23.40	25.41	20.90
	<b>350</b>		24.13	25.42	28.70
<b>SST 94</b>	<b>250</b>		29.08	32.14	33.70
	<b>300</b>		29.40	32.56	29.66
	<b>350</b>		33.49	38.38	31.24

**CVxRWxPD Moorreesburg 2005**  
**Kernel Weight (g 1000 kernels<sup>-1</sup>)**

**D-4**

**Analysis of variance**

Source of variation	d.f.	s.s.	m.s.	v.r.	F pr.
<b>Rep stratum</b>	2	16.250	8.125	0.90	
<b>Rep.Cul stratum</b>					
Cul	1	43.766	43.766	4.83	0.159
Residual	2	18.135	9.067	6.05	
<b>Rep.Cul.RW stratum</b>					
RW	2	6.136	3.068	2.05	0.192
Cul.RW	2	1.038	0.519	0.35	0.717
Residual	8	11.993	1.499	0.72	
<b>Rep.Cul.RW.PD stratum</b>					
PD	2	1.277	0.638	0.31	0.740
Cul.PD	2	1.199	0.600	0.29	0.753
RW.PD	4	5.071	1.268	0.61	0.662
Cul.RW.PD	4	6.880	1.720	0.82	0.524
Residual	24	50.214	2.092		
<b>Total</b>	53	161.958			

**Tables of means**

**Grand mean: 27.84**

<b>Cul</b>	<b>SST 88</b>	<b>SST 94</b>			
	28.74	26.94			
<b>RW</b>	<b>250</b>	<b>300</b>	<b>350</b>		
	27.56	27.64	28.31		
<b>PD</b>	<b>100</b>	<b>175</b>	<b>250</b>		
	27.65	27.83	28.03		
<b>Cul</b>	<b>RW</b>	<b>250</b>	<b>300</b>	<b>350</b>	
<b>SST 88</b>		28.63	28.38	29.20	
<b>SST 94</b>		26.48	26.91	27.42	
<b>Cul</b>	<b>PD</b>	<b>100</b>	<b>175</b>	<b>250</b>	
<b>SST 88</b>		28.71	28.53	28.98	
<b>SST 94</b>		26.60	27.13	27.08	
<b>RW</b>	<b>PD</b>	<b>100</b>	<b>175</b>	<b>250</b>	
<b>250</b>		27.55	27.73	27.40	
<b>300</b>		27.35	27.19	28.40	
<b>350</b>		28.07	28.58	28.29	
<b>Cul</b>	<b>RW</b>	<b>PD</b>	<b>100</b>	<b>175</b>	<b>250</b>
<b>SST 88</b>	<b>250</b>		28.44	28.51	28.95
	<b>300</b>		28.85	27.40	28.88
	<b>350</b>		28.84	29.68	29.10
<b>SST 94</b>	<b>250</b>		26.66	26.94	25.85
	<b>300</b>		25.84	26.97	27.92
	<b>350</b>		27.30	27.48	27.49

**CVxRWxPD Hopefield 2005**  
Heads m<sup>-2</sup>

D-5

<b>Analysis of variance</b>					
<b>Source of variation</b>	<b>d.f.</b>	<b>s.s.</b>	<b>m.s.</b>	<b>v.r.</b>	<b>F pr.</b>
<b>Rep stratum</b>	2	644	322	0.11	
<b>Rep.CV stratum</b>					
CV	1	2108	2108	0.75	0.477
Residual	2	5605	2803	2.47	
<b>Rep.CV.RW stratum</b>					
RW	2	14453	7227	6.38	<b>0.022*</b>
CV.RW	2	395	198	0.17	0.843
Residual	8	9065	1133	0.67	
<b>Rep.CV.RW.PD stratum</b>					
PD	2	5144	2572	1.53	0.238
CV.PD	2	573	287	0.17	0.845
RW.PD	4	2970	743	0.44	0.778
CV.RW.PD	4	9901	2475	1.47	0.243
Residual	24	40478	1687		
<b>Total</b>	53	91337			

**Tables of means**

**Grand mean: 214.0**

<b>CV</b>	<b>SST 88</b>	<b>SST 94</b>			
	207.7	220.2			
<b>RW</b>	<b>250</b>	<b>300</b>	<b>350</b>		
	232.1	217.3	192.5		
<b>PD</b>	<b>100</b>	<b>175</b>	<b>250</b>		
	208.0	206.2	227.7		
<b>CV</b>	<b>RW</b>	<b>250</b>	<b>300</b>	<b>350</b>	
<b>SST 88</b>		228.1	212.6	182.4	
<b>SST 94</b>		236.1	222.0	202.5	
<b>CV</b>	<b>PD</b>	<b>100</b>	<b>175</b>	<b>250</b>	
<b>SST 88</b>		202.0	195.8	225.3	
<b>SST 94</b>		213.9	216.6	230.2	
<b>RW</b>	<b>PD</b>	<b>100</b>	<b>175</b>	<b>250</b>	
<b>250</b>		235.1	222.7	238.7	
<b>300</b>		197.0	214.1	240.7	
<b>350</b>		191.7	181.9	203.8	
<b>CV</b>	<b>RW</b>	<b>PD</b>	<b>100</b>	<b>175</b>	<b>250</b>
<b>SST 88</b>	<b>250</b>		236.4	192.9	255.1
	<b>300</b>		183.0	228.9	225.9
	<b>350</b>		186.7	165.7	194.9
<b>SST 94</b>	<b>250</b>		233.8	252.4	222.2
	<b>300</b>		211.1	199.3	255.6
	<b>350</b>		196.8	198.1	212.7

**CVxRWxPD Hopefield 2005  
Heads plant<sup>-1</sup>**

**D-6**

**Analysis of variance**

<b>Source of variation</b>	<b>d.f.</b>	<b>s.s.</b>	<b>m.s.</b>	<b>v.r.</b>	<b>F pr.</b>
<b>Rep stratum</b>	2	0.00070	0.00035	0.00	
<b>Rep.CV stratum</b>					
CV	1	0.00175	0.00175	0.02	0.892
Residual	2	0.14687	0.07344	1.51	
<b>Rep.CV.RW stratum</b>					
RW	2	0.44991	0.22496	4.62	<b>0.046*</b>
CV.RW	2	0.00513	0.00257	0.05	0.949
Residual	8	0.38992	0.04874	0.60	
<b>Rep.CV.RW.PD stratum</b>					
PD	2	11.55303	5.77652	71.10	<b>&lt;.001**</b>
CV.PD	2	0.02042	0.01021	0.13	0.882
RW.PD	4	0.22598	0.05649	0.70	0.603
CV.RW.PD	4	0.20294	0.05073	0.62	0.650
Residual	24	1.94992	0.08125		
<b>Total</b>	<b>53</b>	<b>14.94657</b>			

**Tables of means**

**Grand mean: 1.346**

<b>CV</b>	<b>SST 88</b>	<b>SST 94</b>			
	1.340	1.352			
<b>RW</b>	<b>250</b>	<b>300</b>	<b>350</b>		
	1.442	1.372	1.223		
<b>PD</b>	<b>100</b>	<b>175</b>	<b>250</b>		
	1.987	1.136	0.914		
<b>CV</b>	<b>RW</b>	<b>250</b>	<b>300</b>	<b>350</b>	
<b>SST 88</b>		1.441	1.353	1.227	
<b>SST 94</b>		1.444	1.392	1.220	
<b>CV</b>	<b>PD</b>	<b>100</b>	<b>175</b>	<b>250</b>	
<b>SST 88</b>		1.958	1.154	0.909	
<b>SST 94</b>		2.017	1.119	0.919	
<b>RW</b>	<b>PD</b>	<b>100</b>	<b>175</b>	<b>250</b>	
<b>250</b>		2.195	1.223	0.910	
<b>300</b>		1.923	1.186	1.008	
<b>350</b>		1.845	1.000	0.825	
<b>CV</b>	<b>RW</b>	<b>PD</b>	<b>100</b>	<b>175</b>	<b>250</b>
<b>SST 88</b>	<b>250</b>		2.202	1.166	0.954
	<b>300</b>		1.823	1.311	0.925
	<b>350</b>		1.847	0.985	0.848
<b>SST 94</b>	<b>250</b>		2.187	1.279	0.865
	<b>300</b>		2.022	1.062	1.091
	<b>350</b>		1.843	1.016	0.801

**CVxRWxPD Hopefield 2005**  
**Kernels head<sup>-2</sup>**

**D-7**

**Analysis of variance**

Source of variation	d.f.(m.v.)	s.s.	m.s.	v.r.	F pr.
<b>Rep stratum</b>	2	108.61	54.30	1.36	
<b>Rep.CV stratum</b>					
CV	1	895.45	895.45	22.39	<b>0.042*</b>
Residual	2	80.00	40.00	1.14	
<b>Rep.CV.RW stratum</b>					
RW	2	134.94	67.47	1.92	0.209
CV.RW	2	173.56	86.78	2.46	0.147
Residual	8	281.71	35.21	0.46	
<b>Rep.CV.RW.PD stratum</b>					
PD	2	156.86	78.43	1.02	0.377
CV.PD	2	187.40	93.70	1.22	0.315
RW.PD	4	198.13	49.53	0.64	0.637
CV.RW.PD	4	179.01	44.75	0.58	0.680
Residual	23(1)	1772.28	77.06		
<b>Total</b>	<b>52(1)</b>	<b>4167.58</b>			

**Tables of means**

**Grand mean: 33.6**

<b>CV</b>	<b>SST 88</b>		<b>SST 94</b>		
	29.6		37.7		
<b>RW</b>	<b>250</b>	<b>300</b>	<b>350</b>		
	32.1	33.0	35.8		
<b>PD</b>	<b>100</b>	<b>175</b>	<b>250</b>		
	34.7	35.0	31.2		
<b>CV</b>	<b>RW</b>	<b>250</b>	<b>300</b>	<b>350</b>	
<b>SST 88</b>		25.7	31.1	31.9	
<b>SST 94</b>		38.4	35.0	39.7	
<b>CV</b>	<b>PD</b>	<b>100</b>	<b>175</b>	<b>250</b>	
<b>SST 88</b>		32.7	31.2	24.7	
<b>SST 94</b>		36.7	38.7	37.7	
<b>RW</b>	<b>PD</b>	<b>100</b>	<b>175</b>	<b>250</b>	
<b>250</b>		33.4	30.2	32.6	
<b>300</b>		34.4	34.7	30.0	
<b>350</b>		36.4	39.9	31.1	
<b>CV</b>	<b>RW</b>	<b>PD</b>	<b>100</b>	<b>175</b>	<b>250</b>
<b>SST 88</b>	<b>250</b>		27.6	27.3	22.3
	<b>300</b>		36.9	30.9	25.3
	<b>350</b>		33.7	35.5	26.6
<b>SST 94</b>	<b>250</b>		39.1	33.2	43.0
	<b>300</b>		31.8	38.5	34.7
	<b>350</b>		39.2	44.4	35.5

**CVxRWxPD Hopefield 2005  
Kernel Weight (g 1000 kernels<sup>-1</sup>)**

**D-8**

**Analysis of variance**

<b>Source of variation</b>	<b>d.f.(mv)</b>	<b>s.s.</b>	<b>m.s.</b>	<b>v.r.</b>	<b>F pr.</b>
<b>Rep stratum</b>	2	3.42	1.71	0.20	
<b>Rep.CV stratum</b>					
CV	1	11.32	11.32	1.36	0.364
Residual	2	16.67	8.34	3.13	
<b>Rep.CV.RW stratum</b>					
RW	2	15.81	7.90	2.97	0.109
CV.RW	2	5.36	2.68	1.01	0.408
Residual	8	21.32	2.67	0.25	
<b>Rep.CV.RW.PD stratum</b>					
PD	2	5.73	2.86	0.27	0.769
CV.PD	2	17.69	8.85	0.82	0.452
RW.PD	4	31.71	7.93	0.74	0.577
CV.RW.PD	4	23.23	5.81	0.54	0.708
Residual	23(1)	247.67	10.77		
<b>Total</b>	52(1)	396.99			

**Tables of means**

**Grand mean: 30.86**

<b>CV</b>	<b>SST 88</b>	<b>SST 94</b>			
	31.32	30.40			
<b>RW</b>	<b>250</b>	<b>300</b>	<b>350</b>		
	30.78	31.56	30.24		
<b>PD</b>	<b>100</b>	<b>175</b>	<b>250</b>		
	30.50	31.29	30.79		
<b>CV</b>	<b>RW</b>	<b>250</b>	<b>300</b>	<b>350</b>	
<b>SST 88</b>		31.36	32.33	30.27	
<b>SST 94</b>		30.21	30.78	30.21	
<b>CV</b>	<b>PD</b>	<b>100</b>	<b>175</b>	<b>250</b>	
<b>SST 88</b>		30.87	32.49	30.60	
<b>SST 94</b>		30.13	30.09	30.98	
<b>RW</b>	<b>PD</b>	<b>100</b>	<b>175</b>	<b>250</b>	
<b>250</b>		29.48	31.28	31.58	
<b>300</b>		32.07	32.52	30.09	
<b>350</b>		29.95	30.07	30.70	
<b>CV</b>	<b>RW</b>	<b>PD</b>	<b>100</b>	<b>175</b>	<b>250</b>
<b>SST 88</b>	<b>250</b>		29.67	32.03	32.37
	<b>300</b>		32.47	33.90	30.63
	<b>350</b>		30.47	31.53	28.80
<b>SST 94</b>	<b>250</b>		29.30	30.53	30.80
	<b>300</b>		31.67	31.13	29.55
	<b>350</b>		29.43	28.60	32.60

**CVxRWxPD Moorreesburg 2006**  
Heads m<sup>2</sup>

**D-9**

**Analysis of variance**

Source of variation	d.f.	s.s.	m.s.	v.r.	F pr.
<b>REP stratum</b>	2	6529.4	3264.7	1.12	
<b>REP.CV stratum</b>					
CV	1	4488.5	4488.5	1.54	0.341
Residual	2	5839.4	2919.7	3.52	
<b>REP.CV.RW stratum</b>					
RW	2	30582.3	15291.1	18.43	<b>0.001*</b>
CV.RW	2	3700.6	1850.3	2.23	0.170
Residual	8	6638.9	829.9	1.19	
<b>REP.CV.RW.PD stratum</b>					
PD	2	15511.9	7756.0	11.09	<b>&lt;.001**</b>
CV.PD	2	1644.8	822.4	1.18	0.326
RW.PD	4	3911.5	977.9	1.40	0.265
CV.RW.PD	4	3545.3	886.3	1.27	0.310
Residual	24	16787.8	699.5		
<b>Total</b>	<b>53</b>	<b>99180.4</b>			

**Tables of means**

**Grand mean: 323.8**

<b>CV</b>	<b>SST015</b>	<b>SST88</b>			
	332.9	314.7			
<b>RW</b>	<b>250</b>	<b>300</b>	<b>350</b>		
	351.6	326.4	293.4		
<b>PD</b>	<b>100</b>	<b>175</b>	<b>250</b>		
	300.5	330.8	340.2		
<b>CV</b>	<b>RW</b>	<b>250</b>	<b>300</b>	<b>350</b>	
<b>SST015</b>		352.6	346.9	299.3	
<b>SST88</b>		350.5	305.9	287.6	
<b>CV</b>	<b>PD</b>	<b>100</b>	<b>175</b>	<b>250</b>	
<b>SST015</b>		301.8	344.4	352.5	
<b>SST88</b>		299.1	317.1	327.9	
<b>RW</b>	<b>PD</b>	<b>100</b>	<b>175</b>	<b>250</b>	
<b>250</b>		316.9	374.7	363.1	
<b>300</b>		311.5	325.6	342.2	
<b>350</b>		273.0	292.1	315.2	
<b>CV</b>	<b>RW</b>	<b>PD</b>	<b>100</b>	<b>175</b>	<b>250</b>
<b>SST015</b>	<b>250</b>		312.0	388.4	357.3
	<b>300</b>		318.5	340.7	381.5
	<b>350</b>		274.9	304.1	318.7
<b>SST88</b>	<b>250</b>		321.8	360.9	368.9
	<b>300</b>		304.4	310.4	303.0
	<b>350</b>		271.1	280.0	311.7

**CVxRWxPD Moorreesburg 2006**  
**Heads plant<sup>-1</sup>**

**D-10**

**Analysis of variance**

<b>Source of variation</b>	<b>d.f.</b>	<b>s.s.</b>	<b>m.s.</b>	<b>v.r.</b>	<b>F pr.</b>
<b>REP stratum</b>	2	0.28619	0.14310	2.57	
<b>REP.CV stratum</b>					
CV	1	0.08997	0.08997	1.62	0.331
Residual	2	0.11120	0.05560	1.61	
<b>REP.CV.RW stratum</b>					
RW	2	0.55601	0.27801	8.05	<b>0.012*</b>
CV.RW	2	0.08415	0.04207	1.22	0.345
Residual	8	0.27640	0.03455	1.44	
<b>REP.CV.RW.PD stratum</b>					
PD	2	16.03570	8.01785	333.08	<b>&lt;.001**</b>
CV.PD	2	0.05059	0.02529	1.05	0.365
RW.PD	4	0.24004	0.06001	2.49	0.070
CV.RW.PD	4	0.05454	0.01363	0.57	0.689
Residual	24	0.57772	0.02407		
<b>Total</b>	<b>53</b>	<b>18.36251</b>			

**Tables of means**

**Grand mean: 1.806**

<b>CV</b>	<b>SST015</b>	<b>SST88</b>			
	1.847	1.765			
<b>RW</b>	<b>250</b>	<b>300</b>	<b>350</b>		
	1.912	1.837	1.669		
<b>PD</b>	<b>100</b>	<b>175</b>	<b>250</b>		
	2.533	1.662	1.222		
<b>CV</b>	<b>RW</b>	<b>250</b>	<b>300</b>	<b>350</b>	
<b>SST015</b>		1.903	1.924	1.712	
<b>SST88</b>		1.920	1.749	1.626	
<b>CV</b>	<b>PD</b>	<b>100</b>	<b>175</b>	<b>250</b>	
<b>SST015</b>		2.533	1.734	1.273	
<b>SST88</b>		2.534	1.590	1.171	
<b>RW</b>	<b>PD</b>	<b>100</b>	<b>175</b>	<b>250</b>	
<b>250</b>		2.687	1.826	1.222	
<b>300</b>		2.609	1.642	1.259	
<b>350</b>		2.304	1.518	1.185	
<b>CV</b>	<b>RW</b>	<b>PD</b>	<b>100</b>	<b>175</b>	<b>250</b>
<b>SST015</b>	<b>250</b>		2.636	1.887	1.186
	<b>300</b>		2.657	1.706	1.410
	<b>350</b>		2.305	1.608	1.223
<b>SST88</b>	<b>250</b>		2.738	1.765	1.258
	<b>300</b>		2.561	1.577	1.109
	<b>350</b>		2.304	1.427	1.146



**CVxRWxPD Moorreesburg 2006  
Kernels head<sup>2</sup>**

**D-11**

**Analysis of variance**

<b>Source of variation</b>	<b>d.f.</b>	<b>s.s.</b>	<b>m.s.</b>	<b>v.r.</b>	<b>F pr.</b>
<b>REP stratum</b>	2	24.20	12.10	0.38	
<b>REP.CV stratum</b>					
CV	1	298.82	298.82	9.51	0.091
Residual	2	62.87	31.44	2.00	
<b>REP.CV.RW stratum</b>					
RW	2	311.27	155.64	9.89	<b>0.007*</b>
CV.RW	2	45.39	22.69	1.44	0.292
Residual	8	125.89	15.74	0.60	
<b>REP.CV.RW.PD stratum</b>					
PD	2	126.48	63.24	2.41	0.112
CV.PD	2	82.87	41.43	1.58	0.227
RW.PD	4	84.17	21.04	0.80	0.537
CV.RW.PD	4	8.15	2.04	0.08	0.988
Residual	24	630.60	26.28		
<b>Total</b>	53	1800.71			

**Tables of means**

**Grand mean: 41.66**

<b>CV</b>	<b>SST015</b>	<b>SST88</b>			
	39.31	44.01			
<b>RW</b>	<b>250</b>	<b>300</b>	<b>350</b>		
	39.38	40.61	44.98		
<b>PD</b>	<b>100</b>	<b>175</b>	<b>250</b>		
	42.43	43.03	39.52		
<b>CV</b>	<b>RW</b>	<b>250</b>	<b>300</b>	<b>350</b>	
<b>SST015</b>		37.11	37.10	43.71	
<b>SST88</b>		41.65	44.13	46.25	
<b>CV</b>	<b>PD</b>	<b>100</b>	<b>175</b>	<b>250</b>	
<b>SST015</b>		41.32	38.98	37.62	
<b>SST88</b>		43.54	47.07	41.43	
<b>RW</b>	<b>PD</b>	<b>100</b>	<b>175</b>	<b>250</b>	
<b>250</b>		39.04	41.69	37.42	
<b>300</b>		40.37	43.21	38.27	
<b>350</b>		47.88	44.18	42.88	
<b>CV</b>	<b>RW</b>	<b>PD</b>	<b>100</b>	<b>175</b>	<b>250</b>
<b>SST015</b>	<b>250</b>		38.28	37.01	36.04
	<b>300</b>		37.75	38.38	35.18
	<b>350</b>		47.93	41.56	41.63
<b>SST88</b>	<b>250</b>		39.79	46.38	38.80
	<b>300</b>		42.98	48.05	41.36
	<b>350</b>		47.84	46.79	44.13

Analysis of variance

Source of variation	d.f.	s.s.	m.s.	v.r.	F pr.
REP stratum	2	22.258	11.129	0.84	
REP.CV stratum					
CV	1	75.379	75.379	5.72	0.139
Residual	2	26.353	13.176	3.42	
REP.CV.RW stratum					
RW	2	1.480	0.740	0.19	0.829
CV.RW	2	4.073	2.036	0.53	0.609
Residual	8	30.812	3.851	0.90	
REP.CV.RW.PD stratum					
PD	2	37.613	18.807	4.39	<b>0.024*</b>
CV.PD	2	3.246	1.623	0.38	0.689
RW.PD	4	12.707	3.177	0.74	0.573
CV.RW.PD	4	11.323	2.831	0.66	0.625
Residual	24	102.871	4.286		
<b>Total</b>	<b>53</b>	<b>328.113</b>			

Tables of means

Grand mean: 39.79

<b>CV</b>	<b>SST015</b>	<b>SST88</b>			
	40.97	38.61			
<b>RW</b>	<b>250</b>	<b>300</b>	<b>350</b>		
	39.66	40.02	39.69		
<b>PD</b>	<b>100</b>	<b>175</b>	<b>250</b>		
	40.87	39.67	38.83		
<b>CV</b>	<b>RW</b>	<b>250</b>	<b>300</b>	<b>350</b>	
<b>SST015</b>		40.89	40.84	41.18	
<b>SST88</b>		38.42	39.20	38.20	
<b>CV</b>	<b>PD</b>	<b>100</b>	<b>175</b>	<b>250</b>	
<b>SST015</b>		41.82	40.73	40.36	
<b>SST88</b>		39.91	38.60	37.31	
<b>RW</b>	<b>PD</b>	<b>100</b>	<b>175</b>	<b>250</b>	
<b>250</b>		41.17	38.73	39.07	
<b>300</b>		40.50	40.73	38.83	
<b>350</b>		40.93	39.53	38.60	
<b>CV</b>	<b>RW</b>	<b>PD</b>	<b>100</b>	<b>175</b>	<b>250</b>
<b>SST015</b>	<b>250</b>		41.73	39.60	41.33
	<b>300</b>		41.80	41.47	39.27
	<b>350</b>		41.93	41.13	40.47
<b>SST88</b>	<b>250</b>		40.60	37.87	36.80
	<b>300</b>		39.20	40.00	38.40
	<b>350</b>		39.93	37.93	36.73

**Analysis of variance**

Source of variation	d.f.	s.s.	m.s.	v.r.	F pr.
<b>REP stratum</b>	2	954.7	477.3	1.00	
<b>REP.CV stratum</b>					
CV	1	1916.7	1916.7	4.00	0.183
Residual	2	957.8	478.9	1.02	
<b>REP.CV.RW stratum</b>					
RW	2	35867.7	17933.8	38.21	<.001**
CV.RW	2	912.7	456.4	0.97	0.419
Residual	8	3754.6	469.3	1.73	
<b>REP.CV.RW.PD stratum</b>					
PD	2	2638.4	1319.2	4.87	0.017*
CV.PD	2	304.8	152.4	0.56	0.577
RW.PD	4	1741.3	435.3	1.61	0.205
CV.RW.PD	4	477.6	119.4	0.44	0.778
Residual	24	6504.8	271.0		
<b>Total</b>	53	56031.1			

**Tables of means**

Grand mean: 231.9

<b>CV</b>	<b>SST015</b>	<b>SST88</b>			
	225.9	237.8			
<b>RW</b>	<b>250</b>	<b>300</b>	<b>350</b>		
	263.9	231.0	200.7		
<b>PD</b>	<b>100</b>	<b>175</b>	<b>250</b>		
	223.1	232.2	240.2		
<b>CV</b>	<b>RW</b>	<b>250</b>	<b>300</b>	<b>350</b>	
SST015		256.3	221.0	200.4	
SST88		271.4	241.0	201.1	
<b>CV</b>	<b>PD</b>	<b>100</b>	<b>175</b>	<b>250</b>	
SST015		220.5	224.9	232.3	
SST88		225.7	239.6	248.2	
<b>RW</b>	<b>PD</b>	<b>100</b>	<b>175</b>	<b>250</b>	
<b>250</b>		262.7	262.7	266.2	
<b>300</b>		211.5	235.6	245.9	
<b>350</b>		195.2	198.4	208.6	
<b>CV</b>	<b>RW</b>	<b>PD</b>	<b>100</b>	<b>175</b>	<b>250</b>
<b>SST015</b>	<b>250</b>		261.3	253.3	254.2
	<b>300</b>		205.9	220.0	237.0
	<b>350</b>		194.3	201.3	205.7
<b>SST88</b>	<b>250</b>		264.0	272.0	278.2
	<b>300</b>		217.0	251.1	254.8
	<b>350</b>		196.2	195.6	211.4

Analysis of variance Source of variation	d.f.	s.s.	m.s.	v.r.	F pr.
REP stratum	2	0.01947	0.00974	0.73	
REP.CV stratum					
CV	1	0.14183	0.14183	10.59	0.083
Residual	2	0.02678	0.01339	0.35	
REP.CV.RW stratum					
RW	2	0.84240	0.42120	11.00	0.005*
CV.RW	2	0.10965	0.05482	1.43	0.294
Residual	8	0.30625	0.03828	1.57	
REP.CV.RW.PD stratum					
PD	2	10.25475	5.12738	210.51	<.001**
CV.PD	2	0.06197	0.03098	1.27	0.298
RW.PD	4	0.15012	0.03753	1.54	0.222
CV.RW.PD	4	0.11676	0.02919	1.20	0.337
Residual	24	0.58457	0.02436		
<b>Total</b>	<b>53</b>	<b>12.61455</b>			

Tables of means

Grand mean: 1.381

<b>CV</b>	<b>SST015</b>	<b>SST88</b>			
	1.432	1.329			
<b>RW</b>	<b>250</b>	<b>300</b>	<b>350</b>		
	1.514	1.415	1.213		
<b>PD</b>	<b>100</b>	<b>175</b>	<b>250</b>		
	1.978	1.214	0.950		
<b>CV</b>	<b>RW</b>	<b>250</b>	<b>300</b>	<b>350</b>	
<b>SST015</b>		1.502	1.505	1.289	
<b>SST88</b>		1.525	1.324	1.138	
<b>CV</b>	<b>PD</b>	<b>100</b>	<b>175</b>	<b>250</b>	
<b>SST015</b>		2.036	1.221	1.039	
<b>SST88</b>		1.920	1.207	0.861	
<b>RW</b>	<b>PD</b>	<b>100</b>	<b>175</b>	<b>250</b>	
<b>250</b>		2.208	1.321	1.012	
<b>300</b>		1.991	1.247	1.007	
<b>350</b>		1.735	1.074	0.832	
<b>CV</b>	<b>RW</b>	<b>PD</b>	<b>100</b>	<b>175</b>	<b>250</b>
<b>SST015</b>	<b>250</b>		2.164	1.280	1.061
	<b>300</b>		2.163	1.216	1.136
	<b>350</b>		1.781	1.165	0.920
<b>SST88</b>	<b>250</b>		2.252	1.362	0.963
	<b>300</b>		1.818	1.277	0.877
	<b>350</b>		1.689	0.982	0.744

Analysis of variance

Source of variation	d.f.(mv)	s.s.	m.s.	v.r.	F pr.
<b>REP stratum</b>	2	569.40	284.70	6.89	
<b>REP.CV stratum</b>					
CV	1	3.28	3.28	0.08	0.805
Residual	2	82.59	41.29	0.93	
<b>REP.CV.RW stratum</b>					
RW	2	369.88	184.94	4.17	0.058
CV.RW	2	21.24	10.62	0.24	0.793
Residual	8	355.21	44.40	1.83	
<b>REP.CV.RW.PD stratum</b>					
PD	2	242.04	121.02	4.99	<b>0.016*</b>
CV.PD	2	52.35	26.17	1.08	0.357
RW.PD	4	10.69	2.67	0.11	0.978
CV.RW.PD	4	110.24	27.56	1.14	0.366
Residual	22(2)	533.93	24.27		
<b>Total</b>	51(2)	2283.74			

Tables of means

Grand mean: 33.69

<b>CV</b>	<b>SST015</b>	<b>SST88</b>			
	33.93	33.44			
<b>RW</b>	<b>250</b>	<b>300</b>	<b>350</b>		
	30.02	35.95	35.09		
<b>PD</b>	<b>100</b>	<b>175</b>	<b>250</b>		
	31.66	32.80	36.61		
<b>CV</b>	<b>RW</b>	<b>250</b>	<b>300</b>	<b>350</b>	
<b>SST015</b>		31.00	36.27	34.53	
<b>SST88</b>		29.05	35.63	35.65	
<b>CV</b>	<b>PD</b>	<b>100</b>	<b>175</b>	<b>250</b>	
<b>SST015</b>		33.14	32.98	35.68	
<b>SST88</b>		30.18	32.61	37.54	
<b>RW</b>	<b>PD</b>	<b>100</b>	<b>175</b>	<b>250</b>	
<b>250</b>		28.04	29.49	32.53	
<b>300</b>		34.39	34.24	39.23	
<b>350</b>		32.56	34.65	38.07	
<b>CV</b>	<b>RW</b>	<b>PD</b>	<b>100</b>	<b>175</b>	<b>250</b>
<b>SST015</b>		<b>250</b>	29.73	29.37	33.89
		<b>300</b>	36.59	33.08	39.15
		<b>350</b>	33.10	36.50	34.00
<b>SST88</b>		<b>250</b>	26.34	29.62	31.17
		<b>300</b>	32.18	35.40	39.31
		<b>350</b>	32.01	32.80	42.13

**CVxRWxPD Hopefield 2006  
Kernel Weight (g 1000 kernels<sup>-1</sup>)**

**D-16**

**Analysis of variance**

Source of variation	d.f.	s.s.	m.s.	v.r.	F pr.
<b>REP stratum</b>	2	12.908	6.454	0.53	
<b>REP.CV stratum</b>					
CV	1	206.507	206.507	16.92	0.054
Residual	2	24.404	12.202	1.90	
<b>REP.CV.RW stratum</b>					
RW	2	17.090	8.545	1.33	0.317
CV.RW	2	13.031	6.516	1.02	0.404
Residual	8	51.310	6.414	1.20	
<b>REP.CV.RW.PD stratum</b>					
PD	2	15.864	7.932	1.49	0.246
CV.PD	2	19.893	9.947	1.86	0.177
RW.PD	4	15.070	3.767	0.71	0.596
CV.RW.PD	4	22.329	5.582	1.05	0.405
Residual	24	128.151	5.340		
<b>Total</b>	53	526.557			

**Tables of means**

**Grand mean: 39.19**

<b>CV</b>	<b>SST015</b>	<b>SST88</b>			
	41.15	37.24			
<b>RW</b>	<b>250</b>	<b>300</b>	<b>350</b>		
	38.51	39.89	39.18		
<b>PD</b>	<b>100</b>	<b>175</b>	<b>250</b>		
	39.71	39.42	38.44		
<b>CV</b>	<b>RW</b>	<b>250</b>	<b>300</b>	<b>350</b>	
<b>SST015</b>		39.78	42.11	41.56	
<b>SST88</b>		37.24	37.67	36.80	
<b>CV</b>	<b>PD</b>	<b>100</b>	<b>175</b>	<b>250</b>	
<b>SST015</b>		42.22	41.67	39.56	
<b>SST88</b>		37.20	37.18	37.33	
<b>RW</b>	<b>PD</b>	<b>100</b>	<b>175</b>	<b>250</b>	
<b>250</b>		39.43	38.60	37.50	
<b>300</b>		40.00	41.00	38.67	
<b>350</b>		39.70	38.67	39.17	
<b>CV</b>	<b>RW</b>	<b>PD</b>	<b>100</b>	<b>175</b>	<b>250</b>
<b>SST015</b>	<b>250</b>		42.33	39.33	37.67
	<b>300</b>		42.33	44.33	39.67
	<b>350</b>		42.00	41.33	41.33
<b>SST88</b>	<b>250</b>		36.53	37.87	37.33
	<b>300</b>		37.67	37.67	37.67
	<b>350</b>		37.40	36.00	37.00

**CVxRWxPD Moorreesburg 2004  
Grain Yield (ton ha<sup>-1</sup>)**

E-1

**Analysis of variance**

Source of variation	d.f.	s.s.	m.s.	v.r.	F pr.
<b>REP stratum</b>	2	0.28259	0.14130	2.38	
<b>REP.WPLOT stratum</b>					
CULT	1	0.08132	0.08132	1.37	0.363
Residual	2	0.11893	0.05946	1.31	
<b>REP.WPLOT.SPLOT stratum</b>					
RW	2	0.52103	0.26052	5.73	<b>0.029*</b>
CULT.RW	2	0.27870	0.13935	3.07	0.103
Residual	8	0.36367	0.04546	1.01	
<b>REP.WPLOT.SPLOT.SSPLOT stratum</b>					
PD	2	0.31818	0.15909	3.55	<b>0.045*</b>
CULT.PD	2	0.59578	0.29789	6.65	<b>0.005*</b>
RW.PD	4	0.12880	0.03220	0.72	0.587
CULT.RW.PD	4	0.16748	0.04187	0.93	0.461
Residual	24	1.07507	0.04479		
<b>Total</b>	53	3.93155			

**Tables of means**

**Grand mean: 2.690**

<b>CULT</b>	<b>SST88</b>	<b>SST94</b>			
	2.651	2.729			
<b>RW</b>	<b>250</b>	<b>300</b>	<b>350</b>		
	2.828	2.635	2.607		
<b>PD</b>	<b>100</b>	<b>175</b>	<b>250</b>		
	2.596	2.691	2.784		
<b>CULT</b>	<b>RW</b>	<b>250</b>	<b>300</b>	<b>350</b>	
SST88		2.690	2.665	2.599	
SST94		2.966	2.606	2.615	
<b>CULT</b>	<b>PD</b>	<b>100</b>	<b>175</b>	<b>250</b>	
SST88		2.705	2.591	2.658	
SST94		2.487	2.791	2.910	
<b>RW</b>	<b>PD</b>	<b>100</b>	<b>175</b>	<b>250</b>	
<b>250</b>		2.679	2.820	2.986	
<b>300</b>		2.628	2.610	2.668	
<b>350</b>		2.480	2.643	2.698	
<b>CULT</b>	<b>RW</b>	<b>PD</b>	<b>100</b>	<b>175</b>	<b>250</b>
<b>SST88</b>	<b>250</b>		2.737	2.626	2.707
	<b>300</b>		2.847	2.502	2.646
	<b>350</b>		2.530	2.646	2.622
<b>SST94</b>	<b>250</b>		2.621	3.013	3.265
	<b>300</b>		2.409	2.719	2.690
	<b>350</b>		2.431	2.639	2.775

**CVxRWxPD Moorreesburg 2005  
Grain Yield (ton ha<sup>-1</sup>)**

**E-2**

<b>Analysis of variance Source of variation</b>	<b>d.f.</b>	<b>s.s.</b>	<b>m.s.</b>	<b>v.r.</b>	<b>F pr.</b>
<b>Rep stratum</b>	2	0.6624	0.3312	3.06	
<b>Rep.Cul stratum</b>					
Cul	1	8.6672	8.6672	79.96	<b>0.012*</b>
Residual	2	0.2168	0.1084	1.18	
<b>Rep.Cul.RW stratum</b>					
RW	2	0.3610	0.1805	1.97	0.201
Cul.RW	2	0.0103	0.0051	0.06	0.946
Residual	8	0.7319	0.0915	0.77	
<b>Rep.Cul.RW.PD stratum</b>					
PD	2	1.4510	0.7255	6.11	<b>0.007**</b>
Cul.PD	2	0.4744	0.2372	2.00	0.158
RW.PD	4	0.0379	0.0095	0.08	0.988
Cul.RW.PD	4	0.2241	0.0560	0.47	0.756
Residual	24	2.8496	0.1187		
<b>Total</b>	<b>53</b>	<b>15.6866</b>			

**Tables of means**

**Grand mean: 2.106**

<b>Cul</b>	<b>SST 88</b>	<b>SST 94</b>			
	1.706	2.507			
<b>RW</b>	<b>250</b>	<b>300</b>	<b>350</b>		
	2.199	2.120	2.000		
<b>PD</b>	<b>100</b>	<b>175</b>	<b>250</b>		
	1.874	2.223	2.222		
<b>Cul</b>	<b>RW</b>	<b>250</b>	<b>300</b>	<b>350</b>	
<b>SST 88</b>		1.809	1.728	1.580	
<b>SST 94</b>		2.588	2.513	2.420	
<b>Cul</b>	<b>PD</b>	<b>100</b>	<b>175</b>	<b>250</b>	
<b>SST 88</b>		1.591	1.709	1.817	
<b>SST 94</b>		2.158	2.736	2.627	
<b>RW</b>	<b>PD</b>	<b>100</b>	<b>175</b>	<b>250</b>	
<b>250</b>		1.969	2.282	2.345	
<b>300</b>		1.884	2.226	2.251	
<b>350</b>		1.770	2.160	2.070	
<b>Cul</b>	<b>RW</b>	<b>PD</b>	<b>100</b>	<b>175</b>	<b>250</b>
<b>SST 88</b>	<b>250</b>		1.628	1.818	1.983
	<b>300</b>		1.633	1.788	1.762
	<b>350</b>		1.511	1.522	1.706
<b>SST 94</b>	<b>250</b>		2.311	2.746	2.707
	<b>300</b>		2.135	2.664	2.740
	<b>350</b>		2.029	2.797	2.434



**CVxRWxPD Moorreesburg 2006**  
**Grain Yield (ton ha<sup>-1</sup>)**

**E-3**

**Analysis of variance**

<b>Source of variation</b>	<b>d.f.</b>	<b>s.s.</b>	<b>m.s.</b>	<b>v.r.</b>	<b>F pr.</b>
<b>REP stratum</b>	2	3.5468	1.7734	33.06	
<b>REP.CV stratum</b>					
CV	1	0.0032	0.0032	0.06	0.830
Residual	2	0.1073	0.0536	0.18	
<b>REP.CV.RW stratum</b>					
RW	2	0.5877	0.2938	1.00	0.409
CV.RW	2	0.7904	0.3952	1.35	0.313
Residual	8	2.3473	0.2934	0.79	
<b>REP.CV.RW.PD stratum</b>					
PD	2	2.2508	1.1254	3.05	0.066
CV.PD	2	0.8470	0.4235	1.15	0.335
RW.PD	4	2.5442	0.6361	1.72	0.178
CV.RW.PD	4	0.2602	0.0651	0.18	0.949
Residual	24	8.8676	0.3695		
<b>Total</b>	53	22.1524			

**Tables of means**

**Grand mean: 5.296**

<b>CV</b>	<b>SST015</b>	<b>SST88</b>			
	5.288	5.303			
<b>RW</b>	<b>250</b>	<b>300</b>	<b>350</b>		
	5.440	5.248	5.199		
<b>PD</b>	<b>100</b>	<b>175</b>	<b>250</b>		
	5.145	5.584	5.158		
<b>CV</b>	<b>RW</b>	<b>250</b>	<b>300</b>	<b>350</b>	
<b>SST015</b>		5.301	5.212	5.351	
<b>SST88</b>		5.580	5.284	5.046	
<b>CV</b>	<b>PD</b>	<b>100</b>	<b>175</b>	<b>250</b>	
<b>SST015</b>		5.143	5.420	5.301	
<b>SST88</b>		5.146	5.748	5.016	
<b>RW</b>	<b>PD</b>	<b>100</b>	<b>175</b>	<b>250</b>	
<b>250</b>		5.037	6.010	5.274	
<b>300</b>		5.057	5.656	5.031	
<b>350</b>		5.340	5.086	5.170	
<b>CV</b>	<b>RW</b>	<b>PD</b>	<b>100</b>	<b>175</b>	<b>250</b>
<b>SST015</b>	<b>250</b>		4.915	5.684	5.303
	<b>300</b>		4.994	5.394	5.248
	<b>350</b>		5.520	5.183	5.351
<b>SST88</b>	<b>250</b>		5.158	6.337	5.245
	<b>300</b>		5.120	5.919	4.814
	<b>350</b>		5.160	4.990	4.988

**CVxRWxPD Moorreesburg 2004  
Protein (%)**

**E-4**

**Analysis of variance**

<b>Source of variation</b>	<b>d.f.</b>	<b>s.s.</b>	<b>m.s.</b>	<b>v.r.</b>	<b>F pr.</b>
<b>REP stratum</b>	2	0.8059	0.4030	0.94	
<b>REP.WPLOT stratum</b>					
CULT	1	0.5283	0.5283	1.23	0.382
Residual	2	0.8564	0.4282	3.77	
<b>REP.WPLOT.SPLOT stratum</b>					
RW	2	0.0359	0.0180	0.16	0.856
CULT.RW	2	0.0139	0.0070	0.06	0.941
Residual	8	0.9086	0.1136	0.49	
<b>REP.WPLOT.SPLOT.SSPLOT stratum</b>					
PD	2	0.1481	0.0741	0.32	0.730
CULT.PD	2	0.4690	0.2345	1.01	0.379
RW.PD	4	0.6709	0.1677	0.72	0.585
CULT.RW.PD	4	1.6598	0.4149	1.79	0.164
Residual	24	5.5666	0.2319		
<b>Total</b>	53	11.6634			

**Tables of means**

**Grand mean: 11.575**

<b>CULT</b>	<b>SST88</b>	<b>SST94</b>			
	11.674	11.476			
<b>RW</b>	<b>250</b>	<b>300</b>	<b>350</b>		
	11.603	11.541	11.582		
<b>PD</b>	<b>100</b>	<b>175</b>	<b>250</b>		
	11.506	11.633	11.587		
<b>CULT</b>	<b>RW</b>	<b>250</b>	<b>300</b>	<b>350</b>	
<b>SST88</b>		11.724	11.626	11.671	
<b>SST94</b>		11.481	11.455	11.493	
<b>CULT</b>	<b>PD</b>	<b>100</b>	<b>175</b>	<b>250</b>	
<b>SST88</b>		11.544	11.661	11.817	
<b>SST94</b>		11.468	11.604	11.356	
<b>RW</b>	<b>PD</b>	<b>100</b>	<b>175</b>	<b>250</b>	
<b>250</b>		11.523	11.570	11.715	
<b>300</b>		11.624	11.638	11.360	
<b>350</b>		11.370	11.690	11.686	
<b>CULT</b>	<b>RW</b>	<b>PD</b>	<b>100</b>	<b>175</b>	<b>250</b>
<b>SST88</b>	<b>250</b>		11.673	11.418	12.081
	<b>300</b>		11.776	11.823	11.281
	<b>350</b>		11.181	11.742	12.090
<b>SST94</b>	<b>250</b>		11.373	11.722	11.348
	<b>300</b>		11.473	11.453	11.439
	<b>350</b>		11.558	11.638	11.281

**CVxRWxPD Moorreesburg 2005  
Protein (%)**

**E-5**

**Analysis of variance**

<b>Source of variation</b>	<b>d.f.</b>	<b>s.s.</b>	<b>m.s.</b>	<b>v.r.</b>	<b>F pr.</b>
<b>Rep stratum</b>	2	10.4150	5.2075	3.49	
<b>Rep.Cul stratum</b>					
Cul	1	0.0012	0.0012	0.00	0.980
Residual	2	2.9865	1.4933	2.20	
<b>Rep.Cul.RW stratum</b>					
RW	2	0.9622	0.4811	0.71	0.521
Cul.RW	2	0.2109	0.1055	0.16	0.859
Residual	8	5.4407	0.6801	1.57	
<b>Rep.Cul.RW.PD stratum</b>					
PD	2	0.3994	0.1997	0.46	0.636
Cul.PD	2	0.0736	0.0368	0.08	0.919
RW.PD	4	2.2867	0.5717	1.32	0.291
Cul.RW.PD	4	1.5568	0.3892	0.90	0.480
Residual	24	10.3981	0.4333		
<b>Total</b>	<b>53</b>	<b>34.7312</b>			

**Tables of means**

**Grand mean: 10.484**

<b>Cul</b>	<b>SST 88</b>	<b>SST 94</b>			
	10.489	10.480			
<b>RW</b>	<b>250</b>	<b>300</b>	<b>350</b>		
	10.346	10.442	10.665		
<b>PD</b>	<b>100</b>	<b>175</b>	<b>250</b>		
	10.527	10.562	10.364		
<b>Cul</b>	<b>RW</b>	<b>250</b>	<b>300</b>	<b>350</b>	
<b>SST 88</b>		10.266	10.512	10.689	
<b>SST 94</b>		10.426	10.373	10.641	
<b>Cul</b>	<b>PD</b>	<b>100</b>	<b>175</b>	<b>250</b>	
<b>SST 88</b>		10.504	10.618	10.345	
<b>SST 94</b>		10.551	10.505	10.384	
<b>RW</b>	<b>PD</b>	<b>100</b>	<b>175</b>	<b>250</b>	
<b>250.</b>		10.136	10.436	10.466	
<b>300.</b>		10.559	10.757	10.011	
<b>350.</b>		10.887	10.492	10.616	
<b>Cul</b>	<b>RW</b>	<b>PD</b>	<b>100</b>	<b>175</b>	<b>250</b>
<b>SST 88</b>	<b>250</b>		9.831	10.409	10.559
	<b>300</b>		10.717	11.059	9.761
	<b>350</b>		10.963	10.388	10.715
<b>SST 94</b>	<b>250</b>		10.440	10.463	10.374
	<b>300</b>		10.401	10.456	10.261
	<b>350</b>		10.811	10.595	10.517

**CVxRWxPD Moorreesburg 2006  
Protein (%)**

**E-6**

**Analysis of variance**

Source of variation	d.f.	s.s.	m.s.	v.r.	F pr.
<b>REP stratum</b>	2	0.67097	0.33549	2.25	
<b>REP.CV stratum</b>					
CV	1	0.98055	0.98055	6.57	0.124
Residual	2	0.29850	0.14925	6.64	
<b>REP.CV.RW stratum</b>					
RW	2	0.01721	0.00861	0.38	0.694
CV.RW	2	0.21893	0.10946	4.87	<b>0.041*</b>
Residual	8	0.17974	0.02247	0.82	
<b>REP.CV.RW.PD stratum</b>					
PD	2	0.22182	0.11091	4.07	<b>0.030*</b>
CV.PD	2	0.00053	0.00026	0.01	0.990
RW.PD	4	0.10395	0.02599	0.95	0.451
CV.RW.PD	4	0.06239	0.01560	0.57	0.685
Residual	24	0.65415	0.02726		
<b>Total</b>	53	3.40873			

**Tables of means**

**Grand mean: 11.262**

<b>CV</b>	<b>SST015</b>	<b>SST88</b>
	11.127	11.397

<b>RW</b>	<b>250</b>	<b>300</b>	<b>350</b>
	11.237	11.275	11.274

<b>PD</b>	<b>100</b>	<b>175</b>	<b>250</b>
	11.172	11.311	11.304

<b>CV</b>	<b>RW</b>	<b>250</b>	<b>300</b>	<b>350</b>
<b>SST015</b>		11.050	11.103	11.229
<b>SST88</b>		11.423	11.448	11.319

<b>CV</b>	<b>PD</b>	<b>100</b>	<b>175</b>	<b>250</b>
<b>SST015</b>		11.036	11.173	11.174
<b>SST88</b>		11.307	11.449	11.435

<b>RW</b>	<b>PD</b>	<b>100</b>	<b>175</b>	<b>250</b>
<b>250</b>		11.090	11.312	11.309
<b>300</b>		11.182	11.369	11.274
<b>350</b>		11.242	11.251	11.329

<b>CV</b>	<b>RW</b>	<b>PD</b>	<b>100</b>	<b>175</b>	<b>250</b>
<b>SST015</b>	<b>250</b>		10.936	11.130	11.085
	<b>300</b>		10.967	11.170	11.171
	<b>350</b>		11.204	11.218	11.265
<b>SST88</b>	<b>250</b>		11.244	11.493	11.533
	<b>300</b>		11.398	11.568	11.377
	<b>350</b>		11.280	11.285	11.393

**CVxRWxPD Moorreesburg 2004**  
**Hectolitre Mass (g hl<sup>-1</sup>)**

**E-7**

**Analysis of variance**

<b>Source of variation</b>	<b>d.f.</b>	<b>s.s.</b>	<b>m.s.</b>	<b>v.r.</b>	<b>F pr.</b>
<b>REP stratum</b>	2	1.2814	0.6407	2.22	
<b>REP.WPLOT stratum</b>					
CULT	1	52.6486	52.6486	182.38	<b>0.005*</b>
Residual	2	0.5773	0.2887	1.87	
<b>REP.WPLOT.SPLOT stratum</b>					
RW	2	0.2051	0.1025	0.66	0.541
CULT.RW	2	0.1192	0.0596	0.39	0.692
Residual	8	1.2364	0.1546	0.23	
<b>REP.WPLOT.SPLOT.SSPLOT stratum</b>					
PD	2	3.8556	1.9278	2.86	0.077
CULT.PD	2	0.7894	0.3947	0.58	0.565
RW.PD	4	0.5874	0.1469	0.22	0.926
CULT.RW.PD	4	0.8559	0.2140	0.32	0.864
Residual	24	16.1987	0.6749		
<b>Total</b>	<b>53</b>	<b>78.3550</b>			

**Tables of means**

**Grand mean: 80.43**

<b>CULT</b>	<b>SST88</b>	<b>SST94</b>			
	81.42	79.44			
<b>RW</b>	<b>250</b>	<b>300</b>	<b>350</b>		
	80.52	80.38	80.40		
<b>PD</b>	<b>100</b>	<b>175</b>	<b>250</b>		
	80.81	80.27	80.21		
<b>CULT</b>	<b>RW</b>	<b>250</b>	<b>300</b>	<b>350</b>	
<b>SST88</b>		81.44	81.39	81.42	
<b>SST94</b>		79.60	79.36	79.37	
<b>CULT</b>	<b>PD</b>	<b>100</b>	<b>175</b>	<b>250</b>	
<b>SST88</b>		81.74	81.43	81.08	
<b>SST94</b>		79.87	79.12	79.34	
<b>RW</b>	<b>PD</b>	<b>100</b>	<b>175</b>	<b>250</b>	
<b>250</b>		80.90	80.21	80.44	
<b>300</b>		80.84	80.20	80.10	
<b>350</b>		80.69	80.41	80.10	
<b>CULT</b>	<b>RW</b>	<b>PD</b>	<b>100</b>	<b>175</b>	<b>250</b>
<b>SST88</b>	<b>250</b>		81.83	81.43	81.05
	<b>300</b>		81.65	81.35	81.19
	<b>350</b>		81.75	81.50	81.02
<b>SST94</b>	<b>250</b>		79.96	78.99	79.84
	<b>300</b>		80.03	79.05	79.01
	<b>350</b>		79.63	79.32	79.17

**CVxRWxPD Moorreesburg 2005  
Hectolitre Mass (g hl<sup>-1</sup>)**

**E-8**

Analysis of variance Source of variation	d.f.	s.s.	m.s.	v.r.	F pr.
<b>Rep stratum</b>	2	7.4683	3.7342	0.42	
<b>Rep.Cul stratum</b>					
Cul	1	57.2062	57.2062	6.39	0.127
Residual	2	17.9183	8.9591	7.79	
<b>Rep.Cul.RW stratum</b>					
RW	2	9.7565	4.8783	4.24	0.056
Cul.RW	2	0.6840	0.3420	0.30	0.751
Residual	8	9.2040	1.1505	1.26	
<b>Rep.Cul.RW.PD stratum</b>					
PD	2	21.5127	10.7564	11.78	<.001**
Cul.PD	2	3.8398	1.9199	2.10	0.144
RW.PD	4	4.5656	1.1414	1.25	0.317
Cul.RW.PD	4	10.4300	2.6075	2.86	<b>0.046*</b>
Residual	24	21.9073	0.9128		
<b>Total</b>	53	164.4928			

**Tables of means**

**Grand mean: 72.14**

<b>Cul</b>	<b>SST 88</b> 71.11	<b>SST 94</b> 73.17			
<b>RW</b>	<b>250</b> 72.09	<b>300</b> 71.65	<b>350</b> 72.69		
<b>PD</b>	<b>100</b> 71.29	<b>175</b> 72.34	<b>250</b> 72.80		
<b>Cul</b>	<b>RW</b>	<b>250</b> 70.93	<b>300</b> 70.60	<b>350</b> 71.81	
<b>SST 88</b>		73.24	72.70	73.57	
<b>SST 94</b>					
<b>Cul</b>	<b>PD</b>	<b>100</b> 70.32	<b>175</b> 70.96	<b>250</b> 72.06	
<b>SST 88</b>		72.26	73.72	73.54	
<b>SST 94</b>					
<b>RW</b>	<b>PD</b>	<b>100</b> 71.73	<b>175</b> 72.04	<b>250</b> 72.50	
<b>250</b>		70.54	71.75	72.67	
<b>300</b>		71.60	73.24	73.23	
<b>350</b>					
<b>Cul</b>	<b>RW</b>	<b>PD</b>	<b>100</b> 70.26	<b>175</b> 70.58	<b>250</b> 71.95
<b>SST 88</b>	<b>250</b> 70.40		70.12	71.29	
	<b>300</b> 70.31		72.17	72.94	
	<b>350</b> 73.19		73.49	73.04	
<b>SST 94</b>	<b>250</b> 70.69		73.37	74.05	
	<b>300</b> 72.89		74.30	73.52	
	<b>350</b>				

**CVxRWxPD Moorreesburg 2006**  
**Hectolitre Mass (g hl<sup>-1</sup>)**

**E-9**

**Analysis of variance**

<b>Source of variation</b>	<b>d.f.</b>	<b>s.s.</b>	<b>m.s.</b>	<b>v.r.</b>	<b>F pr.</b>
<b>REP stratum</b>	2	0.8044	0.4022	0.18	
<b>REP.CV stratum</b>					
CV	1	70.7267	70.7267	30.81	<b>0.031*</b>
Residual	2	4.5911	2.2956	1.51	
<b>REP.CV.RW stratum</b>					
RW	2	3.2844	1.6422	1.08	0.385
CV.RW	2	0.0844	0.0422	0.03	0.973
Residual	8	12.1689	1.5211	1.81	
<b>REP.CV.RW.PD stratum</b>					
PD	2	1.5511	0.7756	0.92	0.411
CV.PD	2	1.4978	0.7489	0.89	0.423
RW.PD	4	3.8578	0.9644	1.15	0.358
CV.RW.PD	4	1.8844	0.4711	0.56	0.693
Residual	24	20.1422	0.8393		
<b>Total</b>	<b>53</b>	<b>120.5933</b>			

**Tables of means**

**Grand mean: 79.99**

<b>CV</b>	<b>SST015</b>	<b>SST88</b>			
	78.84	81.13			
<b>RW</b>	<b>250</b>	<b>300</b>	<b>350</b>		
	80.07	79.66	80.24		
<b>PD</b>	<b>100</b>	<b>175</b>	<b>250</b>		
	79.80	80.21	79.96		
<b>CV</b>	<b>RW</b>	<b>250</b>	<b>300</b>	<b>350</b>	
<b>SST015</b>		78.87	78.53	79.13	
<b>SST88</b>		81.27	80.78	81.36	
<b>CV</b>	<b>PD</b>	<b>100</b>	<b>175</b>	<b>250</b>	
<b>SST015</b>		78.42	79.16	78.96	
<b>SST88</b>		81.18	81.27	80.96	
<b>RW</b>	<b>PD</b>	<b>100</b>	<b>175</b>	<b>250</b>	
<b>250</b>		79.77	80.40	80.03	
<b>300</b>		79.87	79.90	79.20	
<b>350</b>		79.77	80.33	80.63	
<b>CV</b>	<b>RW</b>	<b>PD</b>	<b>100</b>	<b>175</b>	<b>250</b>
<b>SST015</b>	<b>250</b>		78.53	79.00	79.07
	<b>300</b>		78.27	79.20	78.13
	<b>350</b>		78.47	79.27	79.67
<b>SST88</b>	<b>250</b>		81.00	81.80	81.00
	<b>300</b>		81.47	80.60	80.27
	<b>350</b>		81.07	81.40	81.60

Analysis of variance					
Source of variation	d.f.	s.s.	m.s.	v.r.	F pr.
REP stratum	2	0.33188	0.16594	3.25	
REP.WPLOT stratum					
CULT	1	0.12088	0.12088	2.37	0.264
Residual	2	0.10213	0.05107	0.38	
REP.WPLOT.SPLOT stratum					
RW	2	0.80002	0.40001	3.01	0.106
CULT.RW	2	0.05689	0.02845	0.21	0.812
Residual	8	1.06322	0.13290	3.70	
REP.WPLOT.SPLOT.SSPLOT stratum					
PD	2	0.17838	0.08919	2.48	0.105
CULT.PD	2	0.48625	0.24312	6.77	0.005*
RW.PD	4	0.48379	0.12095	3.37	0.025*
CULT.RW.PD	4	0.43565	0.10891	3.03	0.037*
Residual	24	0.86171	0.03590		
<b>Total</b>	<b>53</b>	<b>4.92080</b>			

Tables of means

Grand mean: 1.499

<b>CULT</b>	<b>SST88</b>	<b>SST94</b>			
	1.451	1.546			
<b>RW</b>	<b>250</b>	<b>300</b>	<b>350</b>		
	1.671	1.416	1.410		
<b>PD</b>	<b>150</b>	<b>200</b>	<b>250</b>		
	1.451	1.580	1.466		
<b>CULT</b>	<b>RW</b>	<b>250</b>	<b>300</b>	<b>350</b>	
<b>SST88</b>		1.621	1.410	1.324	
<b>SST94</b>		1.721	1.422	1.495	
<b>CULT</b>	<b>PD</b>	<b>150</b>	<b>200</b>	<b>250</b>	
<b>SST88</b>		1.534	1.442	1.378	
<b>SST94</b>		1.367	1.717	1.555	
<b>RW</b>	<b>PD</b>	<b>150</b>	<b>200</b>	<b>250</b>	
<b>250</b>		1.570	1.673	1.771	
<b>300</b>		1.315	1.502	1.431	
<b>350</b>		1.467	1.564	1.197	
<b>CULT</b>	<b>RW</b>	<b>PD</b>	<b>150</b>	<b>200</b>	<b>250</b>
<b>SST88</b>	<b>250</b>		1.715	1.637	1.510
	<b>300</b>		1.360	1.372	1.498
	<b>350</b>		1.529	1.318	1.126
<b>SST94</b>	<b>250</b>		1.424	1.708	2.031
	<b>300</b>		1.270	1.633	1.364
	<b>350</b>		1.406	1.811	1.269



**CVxRWxPD Hopefield 2005  
Grain Yield (ton ha<sup>-1</sup>)**

E-11

**Analysis of variance**

Source of variation	d.f.	s.s.	m.s.	v.r.	F pr.
<b>Rep stratum</b>	2	0.4216	0.2108	1.17	
<b>Rep.CV stratum</b>					
CV	1	5.6808	5.6808	31.52	<b>0.030*</b>
Residual	2	0.3604	0.1802	4.65	
<b>Rep.CV.RW stratum</b>					
RW	2	0.2280	0.1140	2.94	0.110
CV.RW	2	0.5130	0.2565	6.62	<b>0.020<sup>[1]</sup></b>
Residual	8	0.3099	0.0387	0.38	
<b>Rep.CV.RW.PD stratum</b>					
PD	2	0.0117	0.0059	0.06	0.943
CV.PD	2	0.9769	0.4885	4.85	<b>0.017<sup>[2]</sup></b>
RW.PD	4	0.4122	0.1030	1.02	0.415
CV.RW.PD	4	0.1324	0.0331	0.33	0.856
Residual	24	2.4162	0.1007		
<b>Total</b>	53	11.4630			

**Grand mean: 2.146**

<b>CV</b>	<b>SST 88</b>	<b>SST 94</b>			
	1.821	2.470			
<b>RW</b>	<b>250</b>	<b>300</b>	<b>350</b>		
	2.209	2.172	2.056		
<b>PD</b>	<b>100</b>	<b>175</b>	<b>250</b>		
	2.125	2.156	2.156		
<b>CV</b>	<b>RW</b>	<b>250</b>	<b>300</b>	<b>350</b>	
<b>SST 88</b>		1.774	1.974	1.716	
<b>SST 94</b>		2.644	2.369	2.396	
<b>CV</b>	<b>PD</b>	<b>100</b>	<b>175</b>	<b>250</b>	
<b>SST 88</b>		1.966	1.830	1.668	
<b>SST 94</b>		2.283	2.482	2.644	
<b>RW</b>	<b>PD</b>	<b>100</b>	<b>175</b>	<b>250</b>	
<b>250</b>		2.213	2.080	2.335	
<b>300</b>		2.079	2.236	2.200	
<b>350</b>		2.083	2.152	1.934	
<b>CV</b>	<b>RW</b>	<b>PD</b>	<b>100</b>	<b>175</b>	<b>250</b>
<b>SST 88</b>	<b>250</b>		1.910	1.595	1.817
	<b>300</b>		2.065	2.102	1.755
	<b>350</b>		1.924	1.793	1.432
<b>SST 94</b>	<b>250</b>		2.515	2.565	2.852
	<b>300</b>		2.094	2.370	2.644
	<b>350</b>		2.242	2.511	2.437

<sup>[1]</sup> Although this interaction is indicated as significant in the ANOVA, according to the LSD<sub>(0.05)</sub> RW x CV interaction (LSD = 0.3871) differences are not significant. <sup>[2]</sup> Although this interaction is indicated as significant in the ANOVA, according to the LSD<sub>(0.05)</sub> CV x PD interaction (LSD = 0.3867) differences are not significant.

**CVxRWxPD Hopefield 2006  
Grain Yield (ton ha<sup>-1</sup>)**

**E-12**

**Analysis of variance**

Source of variation	d.f.(mv)	s.s.	m.s.	v.r.	F pr.
<b>REP stratum</b>	2	3.6657	1.8328	4.05	
<b>REP.CV stratum</b>					
CV	1	0.2642	0.2642	0.58	0.525
Residual	2	0.9053	0.4527	2.00	
<b>REP.CV.RW stratum</b>					
RW	2	2.3712	1.1856	5.23	<b>0.035*</b>
CV.RW	2	0.0669	0.0334	0.15	0.865
Residual	8	1.8136	0.2267	0.94	
<b>REP.CV.RW.PD stratum</b>					
PD	2	2.9171	1.4585	6.02	<b>0.008*</b>
CV.PD	2	1.2445	0.6222	2.57	0.099
RW.PD	4	0.2084	0.0521	0.22	0.927
CV.RW.PD	4	0.8276	0.2069	0.85	0.506
Residual	22(2)	5.3278	0.2422		
<b>Total</b>	51(2)	18.2215			

**Tables of means**

**Grand mean: 3.026**

<b>CV</b>	<b>SST015</b>	<b>SST88</b>
	3.096	2.956

<b>RW</b>	<b>250</b>	<b>300</b>	<b>350</b>
	3.030	3.280	2.767

<b>PD</b>	<b>100</b>	<b>175</b>	<b>250</b>
	2.756	2.999	3.323

<b>CV</b>	<b>RW</b>	<b>250</b>	<b>300</b>	<b>350</b>
<b>SST015</b>		3.089	3.314	2.885
<b>SST88</b>		2.971	3.247	2.650

<b>CV</b>	<b>PD</b>	<b>100</b>	<b>175</b>	<b>250</b>
<b>SST015</b>		3.016	3.059	3.212
<b>SST88</b>		2.495	2.938	3.434

<b>RW</b>	<b>PD</b>	<b>100</b>	<b>175</b>	<b>250</b>
<b>250</b>		2.840	3.010	3.239
<b>300</b>		2.904	3.288	3.649
<b>350</b>		2.523	2.698	3.081

<b>CV</b>	<b>RW</b>	<b>PD</b>	<b>100</b>	<b>175</b>	<b>250</b>
<b>SST015</b>	<b>250</b>		3.139	2.923	3.204
	<b>300</b>		3.201	3.203	3.538
	<b>350</b>		2.708	3.052	2.894
<b>SST88</b>	<b>250</b>		2.542	3.097	3.273
	<b>300</b>		2.607	3.374	3.761
	<b>350</b>		2.337	2.345	3.268

**Analysis of variance**

Source of variation	d.f.	s.s.	m.s.	v.r.	F. pr.
<b>REP stratum</b>	2	1.5550	0.7775	1.74	
<b>REP.WPLOT stratum</b>					
CULT	1	2.8313	2.8313	6.34	0.128
Residual	2	0.8933	0.4466	0.96	
<b>REP.WPLOT.SPLOT stratum</b>					
RW	2	1.1584	0.5792	1.24	0.339
CULT.RW	2	2.1982	1.0991	2.35	0.157
Residual	8	3.7346	0.4668	1.61	
<b>REP.WPLOT.SPLOT.SSPLOT stratum</b>					
PD	2	0.1502	0.0751	0.26	0.774
CULT.PD	2	0.0997	0.0498	0.17	0.843
RW.PD	4	2.0681	0.5170	1.78	0.165
CULT.RW.PD	4	0.4406	0.1102	0.38	0.821
Residual	24	6.9617	0.2901		
<b>Total</b>	53	22.0911			

**Tables of means**

Grand mean: 12.843

<b>CULT</b>	<b>SST88</b>	<b>SST94</b>			
	13.072	12.614			
<b>RW</b>	<b>250</b>	<b>300</b>	<b>350</b>		
	12.947	12.636	12.946		
<b>PD</b>	<b>150</b>	<b>200</b>	<b>250</b>		
	12.865	12.770	12.893		
<b>CULT</b>	<b>RW</b>	<b>250</b>	<b>300</b>	<b>350</b>	
<b>SST88</b>		13.416	12.611	13.188	
<b>SST94</b>		12.478	12.660	12.703	
<b>CULT</b>	<b>PD</b>	<b>150</b>	<b>200</b>	<b>250</b>	
<b>SST88</b>		13.153	12.980	13.082	
<b>SST94</b>		12.576	12.560	12.705	
<b>RW</b>	<b>PD</b>	<b>150</b>	<b>200</b>	<b>250</b>	
<b>250</b>		12.819	13.043	12.979	
<b>300</b>		12.468	12.492	12.947	
<b>350</b>		13.308	12.775	12.754	
<b>CULT</b>	<b>RW</b>	<b>PD</b>	<b>150</b>	<b>200</b>	<b>250</b>
<b>SST88</b>	<b>250</b>		13.238	13.590	13.421
	<b>300</b>		12.462	12.507	12.865
	<b>350</b>		13.760	12.843	12.961
<b>SST94</b>	<b>250</b>		12.400	12.497	12.537
	<b>300</b>		12.473	12.478	13.030
	<b>350</b>		12.856	12.707	12.547

**Analysis of variance**

Source of variation	d.f.	s.s.	m.s.	v.r.	F pr.
<b>Rep stratum</b>	2	0.7451	0.3726	0.57	
<b>Rep.CV stratum</b>					
CV	1	17.1869	17.1869	26.35	<b>0.036*</b>
Residual	2	1.3043	0.6521	2.74	
<b>Rep.CV.RW stratum</b>					
RW	2	0.5831	0.2915	1.23	0.343
CV.RW	2	2.0346	1.0173	4.28	0.055
Residual	8	1.9032	0.2379	0.70	
<b>Rep.CV.RW.PD stratum</b>					
PD	2	0.0896	0.0448	0.13	0.877
CV.PD	2	0.1269	0.0634	0.19	0.831
RW.PD	4	1.9768	0.4942	1.45	0.247
CV.RW.PD	4	0.7800	0.1950	0.57	0.684
Residual	24	8.1525	0.3397		
<b>Total</b>	53	34.8830			

**Tables of means**

Grand mean: 11.529

<b>CV</b>	<b>SST 88</b>	<b>SST 94</b>			
	12.093	10.965			
<b>RW</b>	<b>250</b>	<b>300</b>	<b>350</b>		
	11.621	11.384	11.581		
<b>PD</b>	<b>100</b>	<b>175</b>	<b>250</b>		
	11.478	11.531	11.577		
<b>CV</b>	<b>RW</b>	<b>250</b>	<b>300</b>	<b>350</b>	
<b>SST 88</b>		12.401	11.987	11.891	
<b>SST 94</b>		10.841	10.780	11.272	
<b>CV</b>	<b>PD</b>	<b>100</b>	<b>175</b>	<b>250</b>	
<b>SST 88</b>		12.048	12.033	12.197	
<b>SST 94</b>		10.907	11.029	10.957	
<b>RW</b>	<b>PD</b>	<b>100</b>	<b>175</b>	<b>250</b>	
<b>250</b>		11.801	11.631	11.432	
<b>300</b>		11.322	11.148	11.681	
<b>350</b>		11.311	11.814	11.619	
<b>CV</b>	<b>RW</b>	<b>PD</b>	<b>100</b>	<b>175</b>	<b>250</b>
<b>SST 88</b>	<b>250</b>		12.570	12.510	12.123
	<b>300</b>		11.893	11.746	12.322
	<b>350</b>		11.682	11.842	12.147
<b>SST 94</b>	<b>250</b>		11.031	10.752	10.741
	<b>300</b>		10.751	10.550	11.040
	<b>350</b>		10.939	11.786	11.091

Analysis of variance

Source of variation	d.f.	s.s.	m.s.	v.r.	F pr.
REP stratum	2	0.05836	0.02918	0.07	
REP.CV stratum					
CV	1	0.94788	0.94788	2.37	0.264
Residual	2	0.80075	0.40038	9.03	
REP.CV.RW stratum					
RW	2	0.41283	0.20641	4.66	0.046*
CV.RW	2	0.44027	0.22013	4.97	0.040*[1]
Residual	8	0.35464	0.04433	0.69	
REP.CV.RW.PD stratum					
PD	2	0.00029	0.00015	0.00	0.998
CV.PD	2	0.26396	0.13198	2.06	0.149
RW.PD	4	0.08226	0.02057	0.32	0.861
CV.RW.PD	4	0.15653	0.03913	0.61	0.658
Residual	24	1.53410	0.06392		
<b>Total</b>	<b>53</b>	<b>5.05188</b>			

Grand mean: 11.595

CV    **SST015**    **SST88**  
      11.462        11.727

RW    **250**        **300**        **350**  
      11.481        11.609        11.694

PD    **100**        **175**        **250**  
      11.598        11.594        11.593

CV    RW        **250**        **300**        **350**  
**SST015**        11.465        11.373        11.549  
**SST88**        11.497        11.845        11.840

CV    PD        **100**        **175**        **250**  
**SST015**        11.369        11.491        11.527  
**SST88**        11.827        11.697        11.658

RW    PD        **100**        **175**        **250**  
**250**        11.524        11.430        11.489  
**300**        11.543        11.648        11.636  
**350**        11.726        11.703        11.653

CV    RW    PD        **100**        **175**        **250**  
**SST015**        **250**        11.353        11.407        11.636  
                  **300**        11.274        11.462        11.382  
                  **350**        11.480        11.603        11.563  
**SST88** **250**        11.696        11.454        11.342  
                  **300**        11.813        11.833        11.889  
                  **350**        11.973        11.802        11.744

[1] Although this interaction is indicated as significant in the ANOVA, according to the LSD<sub>(0.05)</sub> RW x CV interaction (LSD = 0.6118) differences are not significant.

Analysis of variance

Source of variation	d.f.	s.s.	m.s.	v.r.	F pr.
REP stratum	2	52.846	26.423	0.94	
REP.WPLOT stratum					
CULT	1	78.096	78.096	2.78	0.237
Residual	2	56.210	28.105	3.61	
REP.WPLOT.SPLOT stratum					
RW	2	12.187	6.093	0.78	0.490
CULT.RW	2	6.857	3.429	0.44	0.659
Residual	8	62.356	7.795	2.70	
REP.WPLOT.SPLOT.SSPLOT stratum					
PD	2	1.418	0.709	0.25	0.784
CULT.PD	2	8.502	4.251	1.47	0.249
RW.PD	4	30.824	7.706	2.67	0.057
CULT.RW.PD	4	3.266	0.817	0.28	0.886
Residual	24	69.250	2.885		
Total	53	381.812			

Tables of means

Grand mean: 76.36

<b>CULT</b>	<b>SST88</b>	<b>SST94</b>			
	75.16	77.57			
<b>RW</b>	<b>250</b>	<b>300</b>	<b>350</b>		
	75.75	76.43	76.91		
<b>PD</b>	<b>150</b>	<b>200</b>	<b>250</b>		
	76.37	76.56	76.16		
<b>CULT</b>	<b>RW</b>	<b>250</b>	<b>300</b>	<b>350</b>	
<b>SST88</b>		74.06	75.37	76.06	
<b>SST94</b>		77.44	77.49	77.76	
<b>CULT</b>	<b>PD</b>	<b>150</b>	<b>200</b>	<b>250</b>	
<b>SST88</b>		74.72	75.87	74.90	
<b>SST94</b>		78.03	77.25	77.43	
<b>RW</b>	<b>PD</b>	<b>150</b>	<b>200</b>	<b>250</b>	
<b>250</b>		75.94	76.82	74.50	
<b>300</b>		76.71	76.70	75.89	
<b>350</b>		76.46	76.16	78.10	
<b>CULT</b>	<b>RW</b>	<b>PD</b>	<b>150</b>	<b>200</b>	<b>250</b>
<b>SST88</b>	<b>250</b>		73.79	75.87	72.52
	<b>300</b>		75.38	75.67	75.06
	<b>350</b>		74.99	76.07	77.11
<b>SST94</b>	<b>250</b>		78.10	77.76	76.47
	<b>300</b>		78.05	77.72	76.71
	<b>350</b>		77.93	76.26	79.10

**Analysis of variance**

Source of variation	d.f.	s.s.	m.s.	v.r.	F pr.
<b>Rep stratum</b>	2	47.241	23.621	2.76	
<b>Rep.CV stratum</b>					
CV	1	158.792	158.792	18.58	0.050
Residual	2	17.090	8.545	0.82	
<b>Rep.CV.RW stratum</b>					
RW	2	13.339	6.670	0.64	0.553
CV.RW	2	7.864	3.932	0.38	0.698
Residual	8	83.588	10.449	1.11	
<b>Rep.CV.RW.PD stratum</b>					
PD	2	5.486	2.743	0.29	0.751
CV.PD	2	8.410	4.205	0.45	0.646
RW.PD	4	23.390	5.847	0.62	0.653
CV.RW.PD	4	11.354	2.839	0.30	0.875
Residual	24	226.773	9.449		
<b>Total</b>	53	603.328			

**Tables of means**

Grand mean: 68.71

<b>CV</b>	<b>SST 88</b>	<b>SST 94</b>			
	67.00	70.43			
<b>RW</b>	<b>250</b>	<b>300</b>	<b>350</b>		
	68.83	69.26	68.06		
<b>PD</b>	<b>100</b>	<b>175</b>	<b>250</b>		
	69.06	68.80	68.29		
<b>CV</b>	<b>RW</b>	<b>250</b>	<b>300</b>	<b>350</b>	
<b>SST 88</b>		66.67	67.51	66.82	
<b>SST 94</b>		71.00	71.00	69.29	
<b>CV</b>	<b>PD</b>	<b>100</b>	<b>175</b>	<b>250</b>	
<b>SST 88</b>		67.69	67.29	66.02	
<b>SST 94</b>		70.42	70.31	70.56	
<b>RW</b>	<b>PD</b>	<b>100</b>	<b>175</b>	<b>250</b>	
<b>250</b>		68.37	68.53	69.60	
<b>300</b>		69.57	69.73	68.47	
<b>350</b>		69.23	68.13	66.80	
<b>CV</b>	<b>RW</b>	<b>PD</b>	<b>100</b>	<b>175</b>	<b>250</b>
<b>SST 88</b>	<b>250</b>		66.33	66.00	67.67
	<b>300</b>		67.93	68.53	66.07
	<b>350</b>		68.80	67.33	64.33
<b>SST 94</b>	<b>250</b>		70.40	71.07	71.53
	<b>300</b>		71.20	70.93	70.87
	<b>350</b>		69.67	68.93	69.27

Analysis of variance

Source of variation	d.f.	s.s.	m.s.	v.r.	F pr.
REP stratum	2	25.055	12.527	25.02	
REP.CV stratum					
CV	1	50.074	50.074	100.00	0.010*
Residual	2	1.001	0.501	0.17	
REP.CV.RW stratum					
RW	2	6.108	3.054	1.04	0.396
CV.RW	2	3.806	1.903	0.65	0.548
Residual	8	23.473	2.934	1.31	
REP.CV.RW.PD stratum					
PD	2	3.508	1.754	0.78	0.468
CV.PD	2	13.019	6.510	2.91	0.074
RW.PD	4	15.447	3.862	1.72	0.177
CV.RW.PD	4	25.074	6.269	2.80	0.049*
Residual	24	53.751	2.240		
<b>Total</b>	<b>53</b>	<b>220.317</b>			

Tables of means

Grand mean: 75.99

CV	SST015	SST88
	76.96 7	5.03

RW	250	300	350
	75.79	76.47	75.72

PD	100	175	250
	75.67	76.02	76.29

CV	RW	250	300	350
SST015		76.38	77.64	76.84
SST88		75.20	75.29	74.60

CV	PD	100	175	250
SST015		77.11	77.18	76.58
SST88		74.22	74.87	76.00

RW	PD	100	175	250
250		76.33	75.63	75.40
300		75.33	77.03	77.03
350		75.33	75.40	76.43

CV	RW	PD	100	175	250
SST015		250	77.67	75.47	76.00
	300		77.53	78.13	77.27
	350		76.13	77.93	76.47
SST88	250		75.00	75.80	74.80
	300		73.13	75.93	76.80
	350		74.53	72.87	76.40